

ASSEMBLY INSTRUCTIONS

INSTRUCTIONS DE MONTAGE

FULL LOFT BED WITH DESK, SHELVES

LIT LOFT COMPLET AVEC BUREAU, ÉTAGÈRES

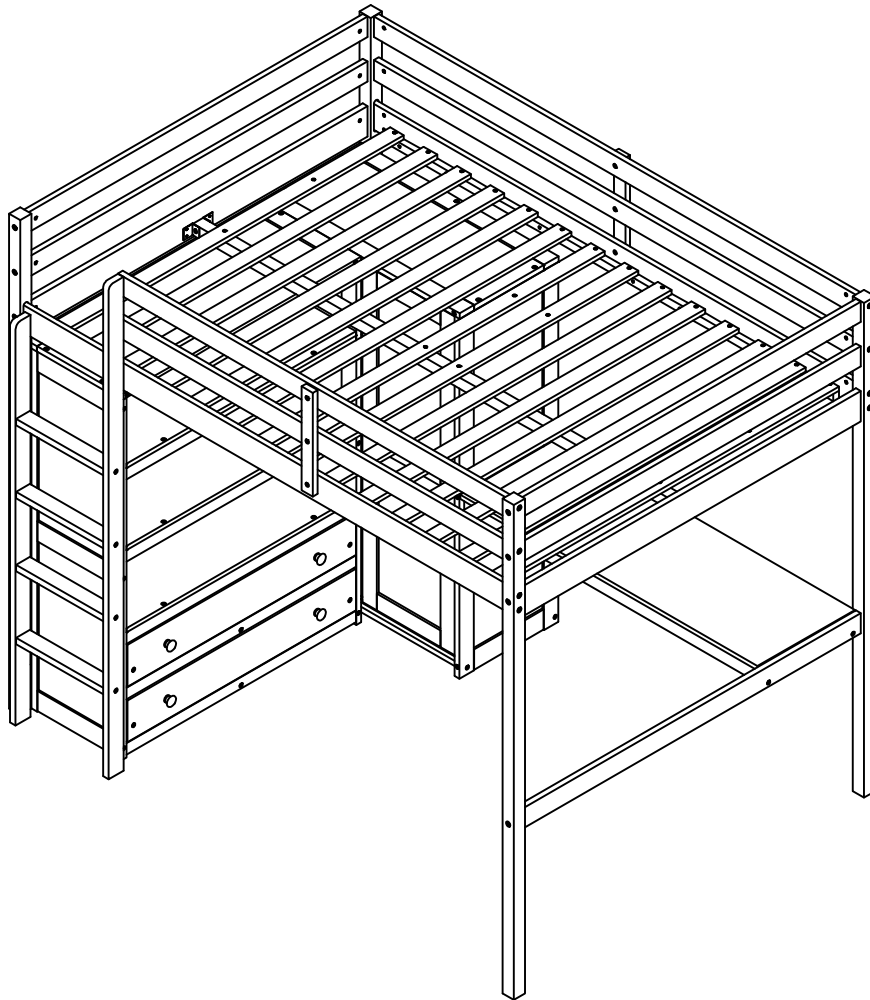

SAFETY WARNINGS AND GENERAL NOTES:

Follow the information on the warnings on the bunk bed end structure and on the carton. Do not remove the warning label from the bed. Always use the recommended size mattress on mattress support, or both, to help prevent the likelihood of entrapment or falls.

The top surface of the mattress must be at least 5*inch (127mm) below the upper edge of the guardrail.

Do not allow children under 6 years of age to use the upper bunk.

Periodically check and ensure the guardrail, ladder and other components are in their proper position, free from damage, and all connectors are tight.

Do not allow horseplay on or under beds.

Always prohibit jumping on the bed.

Prohibit more than one person on upper bunk.

Always use the ladder for entering and leaving the upper bunk.

Do not use substitute parts. Contact the manufacturer or dealer for replacement parts.

Use of a night-light may provide added safety precaution for a child using the upper bunk.

Always use guardrails on both long sides of the upper bunk.

If the bunk bed will be placed next to a wall, the guardrail that runs the full length of the bed should be placed against the wall to prevent entrapment between the bed and the wall.

The use of water or sleep flotation mattresses is prohibited.

STRANGULATION HAZARD-Never attach or hang items to any part of the bunk bed that are not designed for use with the bed.

Keep these instructions for future reference.

We recommend assembling your bunk bed on the shipping carton to protect your floor or carpet.

Be certain all staples are out of the box before beginning assembly on the shipping carton.

THIS BED IS DESIGNED TO USE A FULL MATTRESSES 54" WIDE X 74"-75" LONG WITH THE TOTAL THICKNESS NOT EXCEEDING 6" FOR UPPER BUNK, SURFACE OF MATTRESS MUST BE AT LEAST 5" (127MM) BELOW THE UPPER EDGE OF GUARDRAILS.

Replacement Parts:

Replacement Parts, including additional guardrails, may be obtained from any of our dealers.

AVERTISSEMENTS DE SÉCURITÉ ET REMARQUES GÉNÉRALES :

Suivez les informations sur les avertissements figurant sur la structure d'extrémité du lit superposé et sur le carton. Ne retirez pas l'étiquette d'avertissement du lit. Utilisez toujours le matelas de taille recommandée sur le support de matelas, ou les deux, pour éviter tout risque de coincement ou de chute.

La surface supérieure du matelas doit être à au moins 5*poüces (127 mm) sous le bord supérieur du garde-corps.

Ne laissez pas les enfants de moins de 6 ans utiliser le lit supérieur.

Vérifiez périodiquement et assurez-vous que le garde-corps, l'échelle et les autres composants sont dans leur bonne position, exempts de dommages et que tous les connecteurs sont bien serrés.

Ne permettez pas les chahuts sur ou sous les lits.

Interdisez toujours de sauter sur le lit.

Interdire plus d'une personne sur la couchette supérieure.

Utilisez toujours l'échelle pour entrer et sortir du lit supérieur.

N'utilisez pas de pièces de rechange. Contactez le fabricant ou le revendeur pour obtenir des pièces de rechange.

L'utilisation d'une veilleuse peut fournir une précaution supplémentaire en matière de sécurité pour un enfant utilisant le lit supérieur.

Utilisez toujours des garde-corps sur les deux côtés longs du lit supérieur.

Si le lit superposé doit être placé à côté d'un mur, le garde-corps qui s'étend sur toute la longueur du lit doit être placé contre le mur pour éviter tout coincement entre le lit et le mur.

L'utilisation de matelas flottants à eau ou de sommeil est interdite.

RISQUE D'ÉTRANGULATION - N'attachez ou ne suspendez jamais d'objets à une partie du lit superposé qui ne sont pas conçus pour être utilisés avec le lit.

Conservez ces instructions pour référence future.

Nous vous recommandons d'assembler votre lit superposé sur le carton d'expédition pour protéger votre sol ou votre tapis.

Assurez-vous que toutes les agrafes sont sorties de la boîte avant de commencer l'assemblage sur le carton d'expédition.

CE LIT EST CONÇU POUR UTILISER UN MATELAS COMPLET DE 54" DE LARGE X 74" - 75" DE LONG AVEC L'ÉPAISSEUR TOTALE NE DÉPASSANT PAS 6" POUR LE COUCHE SUPÉRIEUR, LA SURFACE DU MATELAS DOIT ÊTRE AU MOINS 5" (127 MM) EN DESSOUS DU BORD SUPÉRIEUR DES GARDE-CORPS.

Pièces de rechange :

Les pièces de rechange, y compris les garde-corps supplémentaires, peuvent être obtenues auprès de l'un de nos revendeurs.





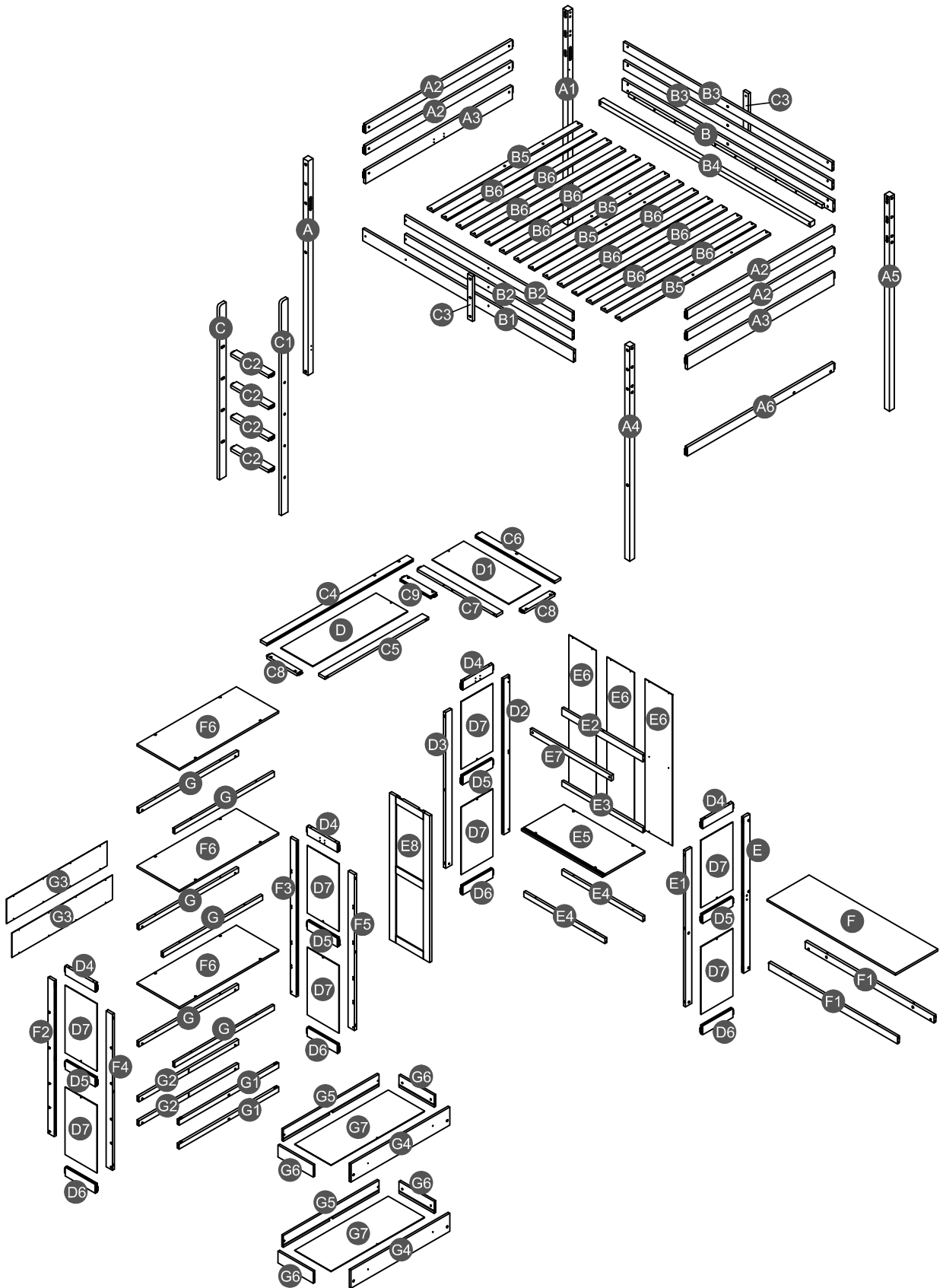





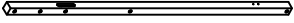

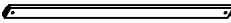
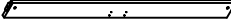

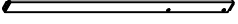



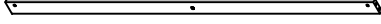
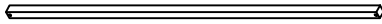

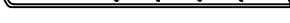



Detail View

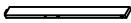





Vue Détaillée

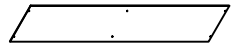

Part list



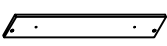









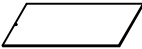

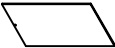

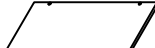
Liste des pièces

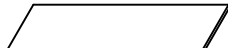
<p>A</p>  <p>Leg (Left front) - 1pc Pied (Avant gauche)</p>	<p>A1</p>  <p>Leg (Left back) - 1pc Pied (Arrière gauche)</p>	<p>A2</p>  <p>Upper horizontal bar HB/FB- 4pcs Barre horizontale supérieur HB/FB</p>
<p>A3</p>  <p>Divider horizontal bar HB/FB- 2pcs Barre de séparation horizontale HB/FB</p>	<p>A4</p>  <p>Leg (Right front) - 1pc Pied (Avant droit)</p>	<p>A5</p>  <p>Leg (Right back) - 1pc Pied (arrière droit)</p>
<p>A6</p>  <p>Lower horizontal bar HB - 1pc Barre horizontale inférieure HB</p>	<p>B</p>  <p>Upper side rail (Back) - 1pc Rail latéral supérieur (Arrière)</p>	<p>B1</p>  <p>Upper side rail (Front) - 1pc Rail latéral supérieur (Avant)</p>
<p>B2</p>  <p>Short guard rail (Front) - 2pcs Garde-corps court (avant)</p>	<p>B3</p>  <p>Long guard rail (Back) - 2pcs Garde-corps long (Arrière)</p>	<p>B4</p>  <p>Lower support slat - 1pc Latte de support inférieure</p>
<p>C</p>  <p>Ladder (left) - 1pc Échelle (gauche)</p>	<p>C1</p>  <p>Ladder (right) - 1pc Échelle (droite)</p>	<p>C2</p>  <p>Step ladder - 4pcs Escabeau</p>
<p>C3</p>  <p>Vertical guard rail - 2pcs Garde-corps vertical</p>	<p>C4</p>  <p>Upper horizontal bar (Back) - 1pc Barre horizontale supérieure (Arrière)</p>	<p>C5</p>  <p>Upper horizontal bar (Front) - 1pc Barre horizontale supérieure (avant)</p>
<p>C6</p>  <p>Upper horizontal bar (right) - 1pc Barre horizontale supérieure (droit)</p>	<p>C7</p>  <p>Upper horizontal bar (left) - 1pc Barre horizontale supérieure (gauche)</p>	<p>C8</p>  <p>Upper horizontal bar - 2pcs Barre horizontale supérieure</p>
<p>C9</p>  <p>Upper divider horizontal bar- 1pc Barre horizontale de séparation supérieure</p>	<p>D4</p>  <p>Upper horizontal bar - 4pcs Barre horizontale supérieur</p>	<p>D5</p>  <p>Divider horizontal bar - 4pcs Barre de séparation horizontale</p>
<p>D6</p>  <p>Lower horizontal bar - 4pcs Barre horizontale inférieure</p>	<p>E2</p>  <p>Upper horizontal bar (back) - 1pc Barre horizontale supérieur (arrière)</p>	<p>E3</p>  <p>Divider horizontal bar (back) - 1pc Barre de séparation horizontale (arrière)</p>

<p>E4</p>  <p>Lower horizontal bar - 2pcs Barre horizontale inférieure</p>	<p>E6</p>  <p>Back panel - 3pcs Panneau arrière</p>	<p>G</p>  <p>Upper horizontal bar - 6pcs Barre horizontale supérieur</p>
<p>G1</p>  <p>Lower horizontal bar (front) - 2pcs Barre horizontale inférieure (avant)</p>	<p>G2</p>  <p>Lower horizontal bar (back) - 2pcs Barre horizontale inférieure (arrière)</p>	<p>G3</p>  <p>Back panel - 2pcs Panneau arrière</p>
<p>G4</p>  <p>Front drawer panel - 2pcs Panneau de tiroir avant</p>	<p>G5</p>  <p>Back drawer panel - 2pcs Panneau de tiroir arrière</p>	<p>G6</p>  <p>Left / right drawer panel - 4pcs Panneau de tiroir gauche/droit</p>

Part list & Hardware list







Liste des pièces & liste du matériel

<p>B5</p>  <p>Slat - 4pcs Latte</p>	<p>B6</p>  <p>Slat - 10pcs Latte</p>	<p>D</p>  <p>Upper panel (Left) - 1pc Panneau supérieur (gauche)</p>
<p>D1</p>  <p>Upper panel (Right) - 1pc Panneau supérieur (droite)</p>	<p>D2</p>  <p>Vertical bar (Left Back) - 1pc Barre verticale (Arrière gauche)</p>	<p>D3</p>  <p>Vertical bar (Left Front) - 1pc Barre verticale (Avant gauche)</p>
<p>D7</p>  <p>Side panel - 8pcs Panneau latéral</p>	<p>E</p>  <p>Leg (Right back) - 1pc Pied (arrière droit)</p>	<p>E1</p>  <p>Leg (Right front) - 1pc Pied (Avant droit)</p>
<p>E5</p>  <p>Bottom panel - 1pc Panneau inférieur</p>	<p>E7</p>  <p>Hanging bar - 1pc Barre de suspension</p>	<p>E8</p>  <p>Door sliding - 1pc Porte coulissante</p>
<p>F</p>  <p>Top table - 1pc Table haute</p>	<p>F1</p>  <p>Horizontal bar - 2pcs Barre horizontale</p>	<p>F2</p>  <p>Vertical bar (Left Back) - 1pc Barre verticale (Arrière gauche)</p>
<p>F3</p>  <p>Leg (Right back) - 1pc Pied (arrière droit)</p>	<p>F4</p>  <p>Vertical bar (Left Front) - 1pc Barre verticale (Avant gauche)</p>	<p>F5</p>  <p>Leg (Right front) - 1pc Pied (Avant droit)</p>
<p>F6</p>  <p>Shelf panel - 3pcs Panneau d'étagère</p>	<p>G7</p>  <p>Drawer bottom - 2pcs Fond de tiroir</p>	

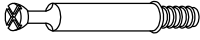
Hardware List

Liste du matériel

1  Ø10*40mm	2  Ø10*20mm	3  Ø8*30mm
Wood dowel (6pcs) Cheville en bois	Wood dowel (1pc) Cheville en bois	Wood dowel (36pcs) Cheville en bois
4  (Ø15)1/4"*100mm	5  (Ø15)1/4"*80mm	6  (Ø12)1/4"*60mm
Hex-Head bolts (16pcs) Boulons à tête hexagonale	Hex-Head bolts (14pcs) Boulons à tête hexagonale	Hex-Head bolts (50pcs) Boulons à tête hexagonale
7  (Ø12)1/4"*40mm	8  (Ø12)1/4"*30mm	9  (Ø12)1/4"*15mm
Hex-Head bolts (6pcs) Boulons à tête hexagonale	Hex-Head bolts (6pcs) Boulons à tête hexagonale	Hex-Head bolts (2pcs) Boulons à tête hexagonale
10  1/4"*15 (9.5mm)	11  Ø4*30mm	12  (1/4")4.5*58mm
Horizontal-Hole bolts(80pcs) Boulons à trou horizontal	Wood screws (32pcs) Vis	Allen key (2pcs) Clé Allen
13  Ø3.5*19mm	14  Ø3.5*15mm	15  Ø3.5*15mm
Wood screws (8pcs) Vis	Wood screws (38pcs) Vis	Wood screws (32pcs) Vis
16  (Ø12)1/4"*65mm	17  (Ø12)1/4"*40mm	18  (Ø13)1/4"*14mm
Hex-Head bolts (32pcs) Boulons à tête hexagonale	Hex-Head bolts (25pcs) Boulons à tête hexagonale	Connect bolt (4pcs) Connecter le boulon
19  Ø38*31mm	20  3/16"*25mm	21  116*40*27mm
Pine Knob (4pcs) Bouton en pin	Ph zinc(Knob) (4pcs) Ph zinc (bouton)	Metal bracket (2pcs) Support métallique
22  63*40*30*1.2mm	23  365*58*28 mm	24  340*30mm
Metal bracket (2pcs) Support métallique	Lower slider drawer (2pcs) Tiroir coulissant inférieur	Upper slider drawer (2pcs) Tiroir coulissant supérieur

25  Ø7"*35mm	26  Ø14*9mm	27  L58*51*12mm
Cam lock (5pcs) Serrure à came	Cam lock (5pcs) Serrure à came	Sliding wheel (2pcs) Roue coulissante
28  L58*51*12mm	29  50*24*24*2mm	30  24*28*28*2mm
Sliding wheel (2pcs) Roue coulissante	Metal bracket (1pc) Support métallique	Metal bracket (2pcs) Support métallique



ASSEMBLY TOOLS REQUIRED (NOT INCLUDED)
OUTILS D'ASSEMBLAGE REQUIS (NON INCLUS)



PLEASE BE CAREFUL DO NOT DAMAGE THE HOLE POSITION WHEN YOU USE POWER TOOLS !
NE PAS UTILISEZ DES OUTILS ÉLECTRIQUES POUR ASSEMBLER CE PRODUIT !

STEP 1:

ÉTAPE

5	
14PCS	
10	
14PCS	

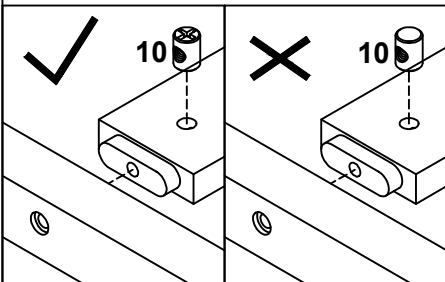
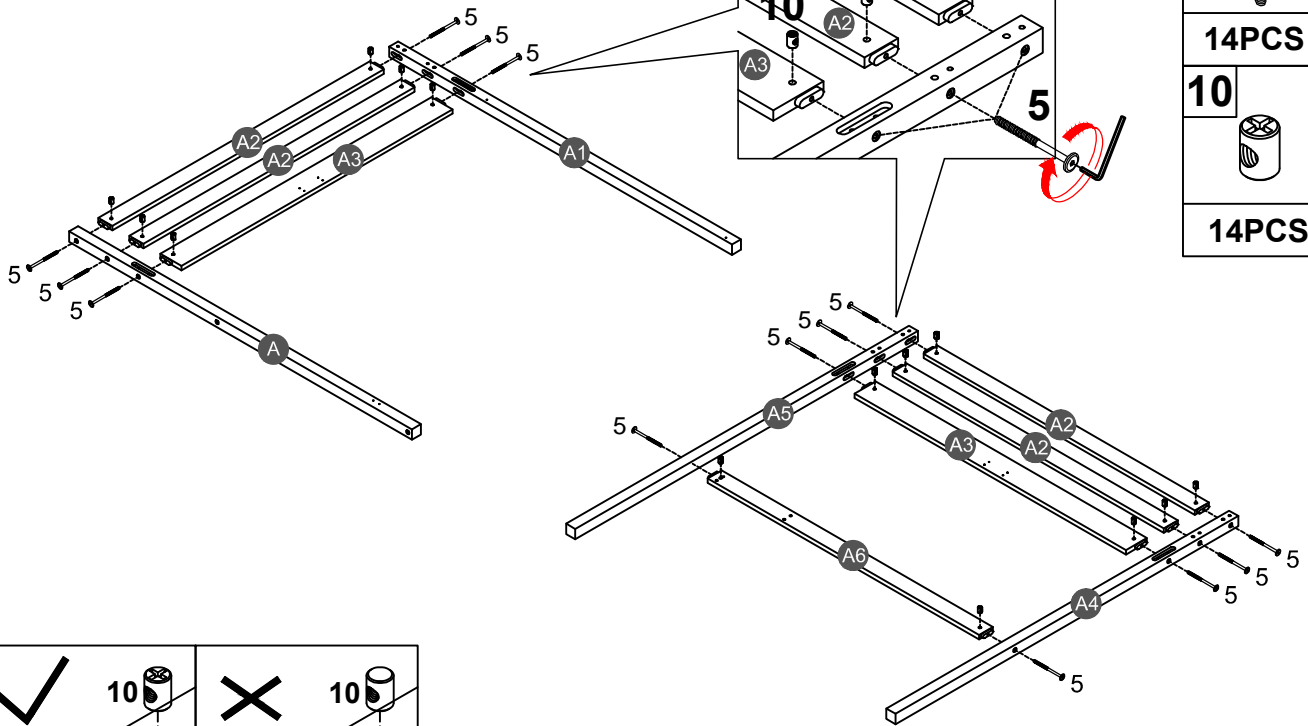



Note: Part 10 will face up with the "x" mark on it, otherwise it cannot be tightened

Remarque: La pièce 10 sera face vers le haut avec la marque "x", sinon elle ne peut pas être serrée.

STEP 2:

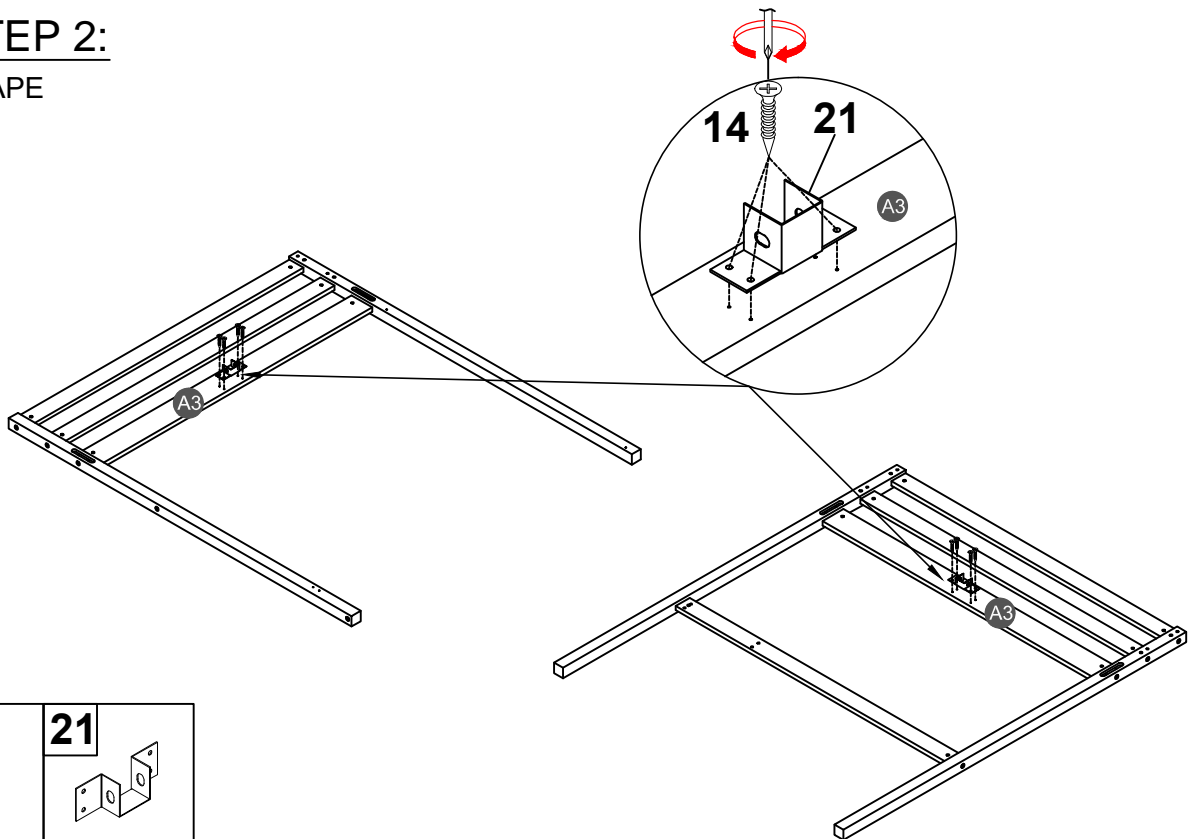
ÉTAPE



14	21
	
8PCS	2PCS

STEP 3:
ÉTAPE

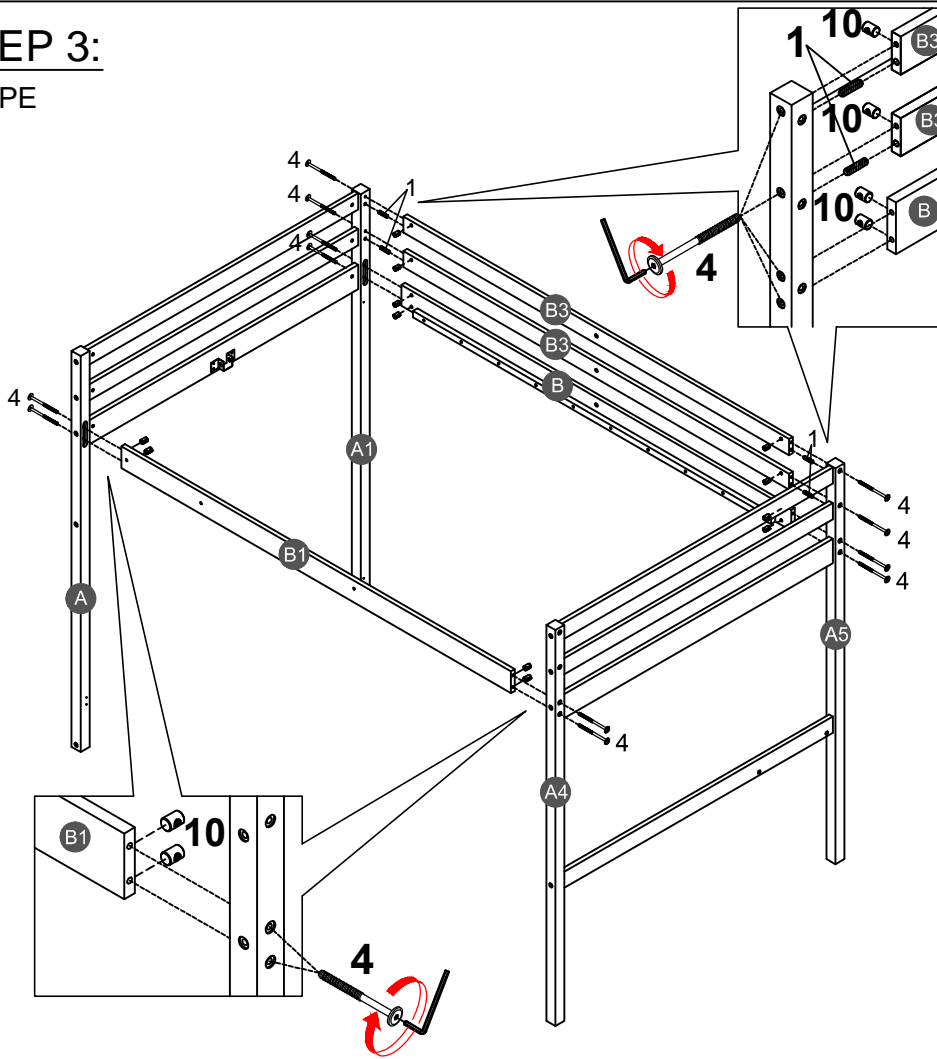

1	
4PCS	
4	
12PCS	
10	
12PCS	



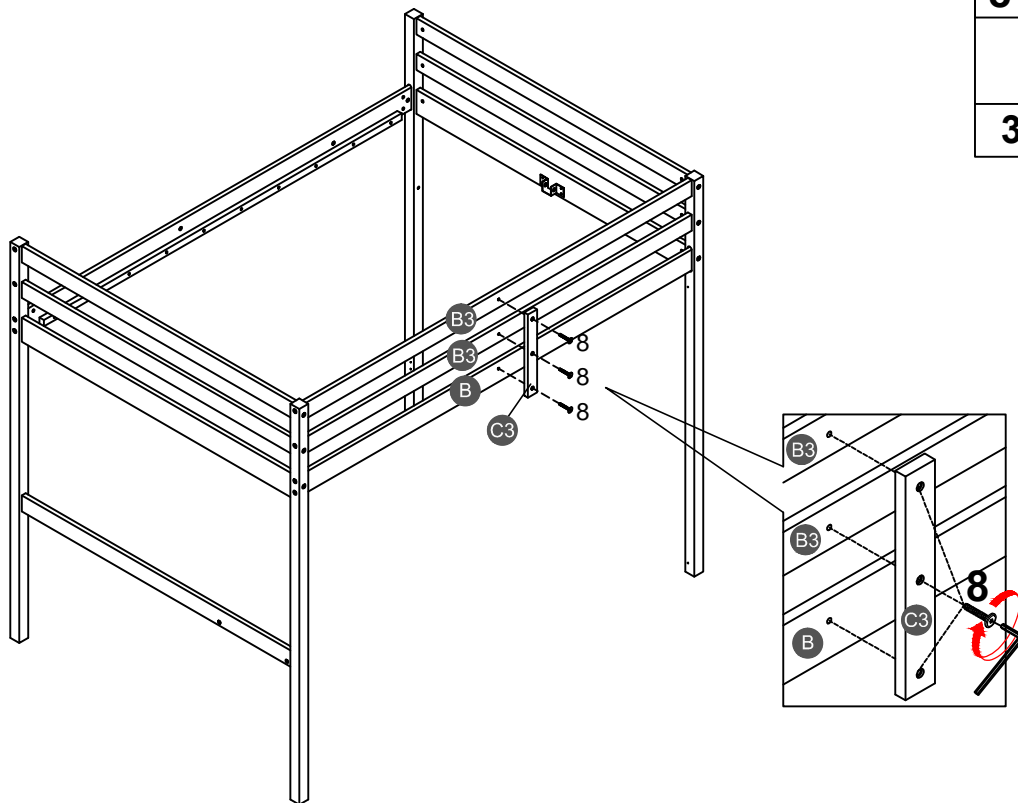

STEP 4:
ÉTAPE

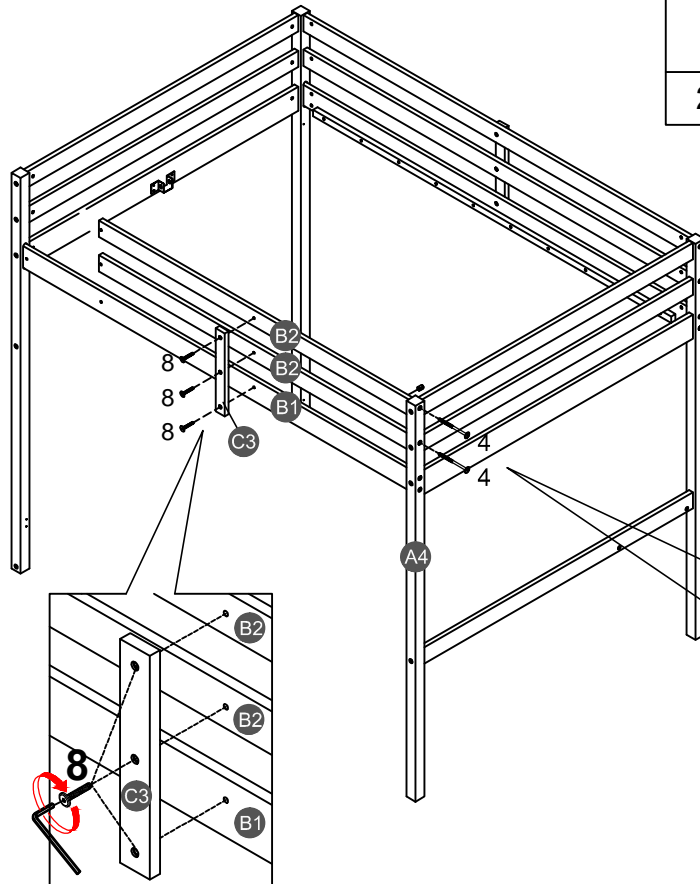

8	
3PCS	

STEP 5:
ÉTAPE





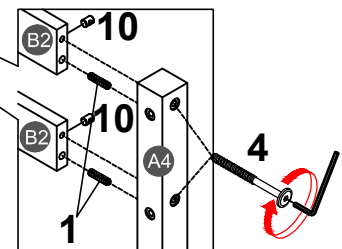
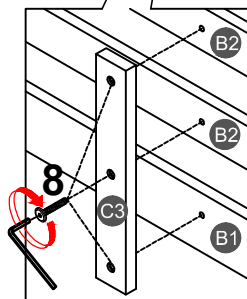

1 	4 	8 
2PCS	2PCS	3PCS
		10 
		2PCS

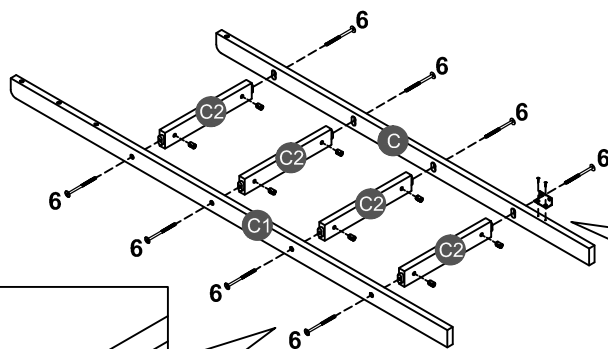

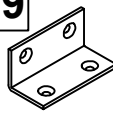

STEP 6:
ÉTAPE

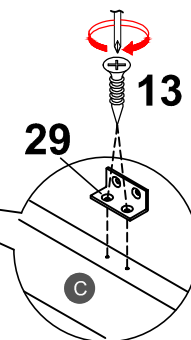
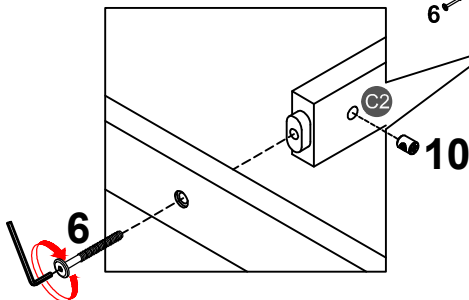

6 	10 	29 	13 
8PCS	8PCS	1PC	2PCS



STEP 7:
ÉTAPE

7		13	
4PCS		2PCS	

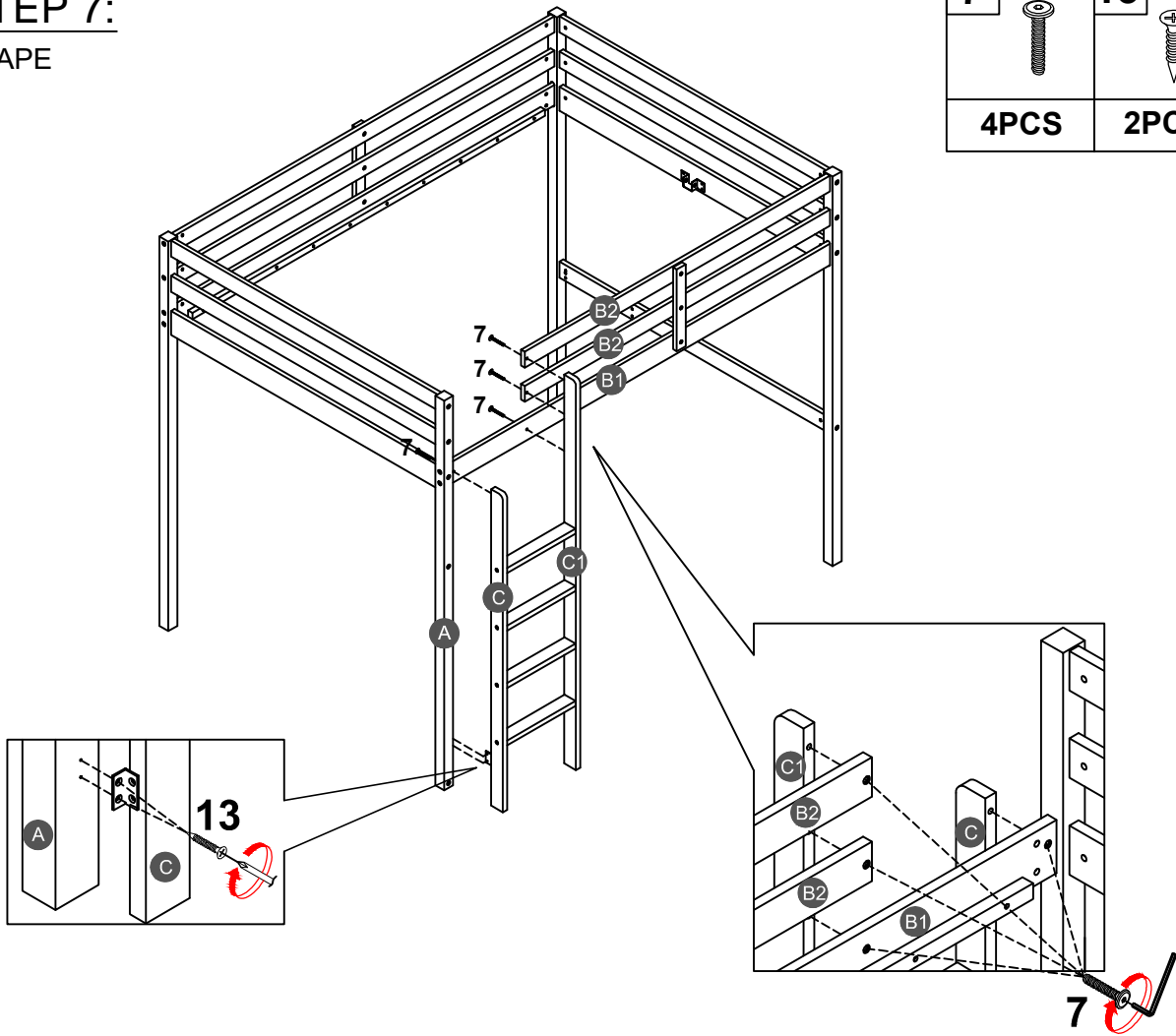

STEP 8:
ÉTAPE

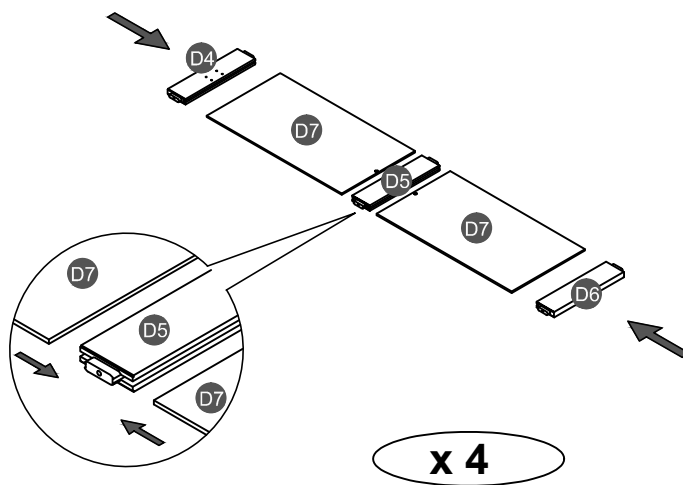

STEP 09:

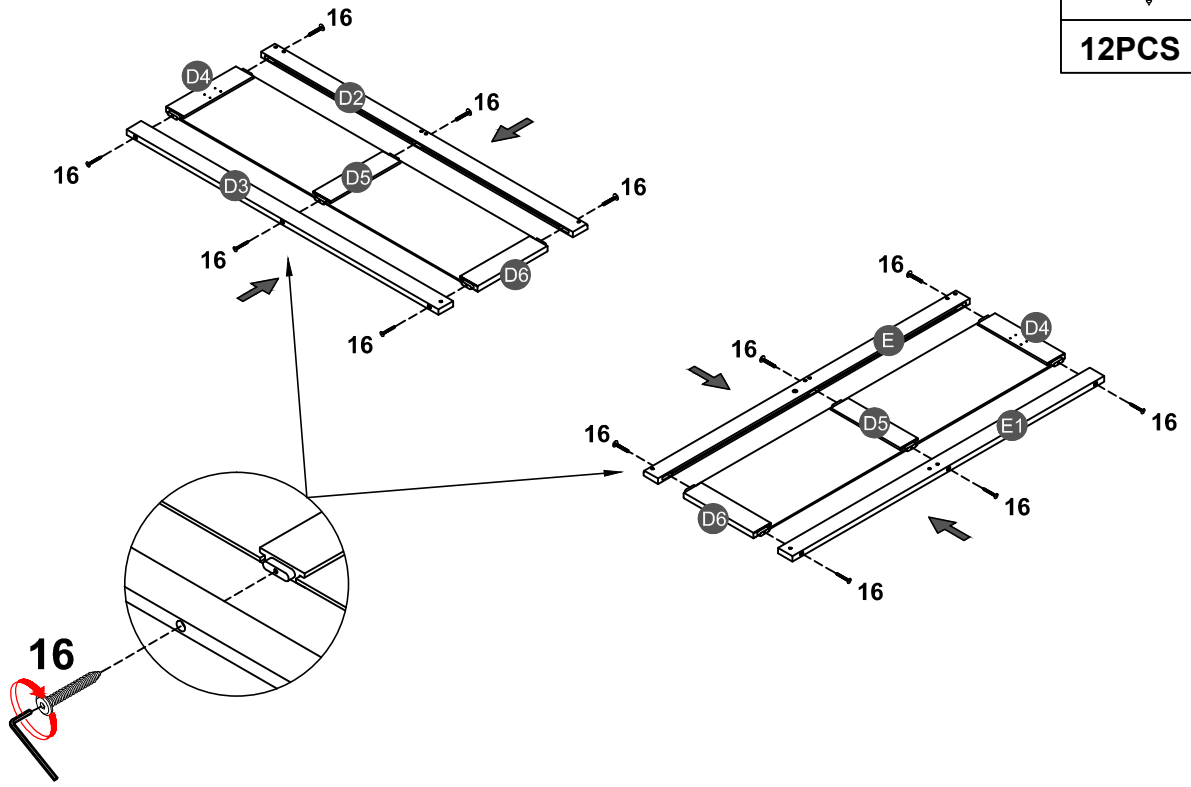

ÉTAPE

16	
12PCS	



STEP 10:

ÉTAPE

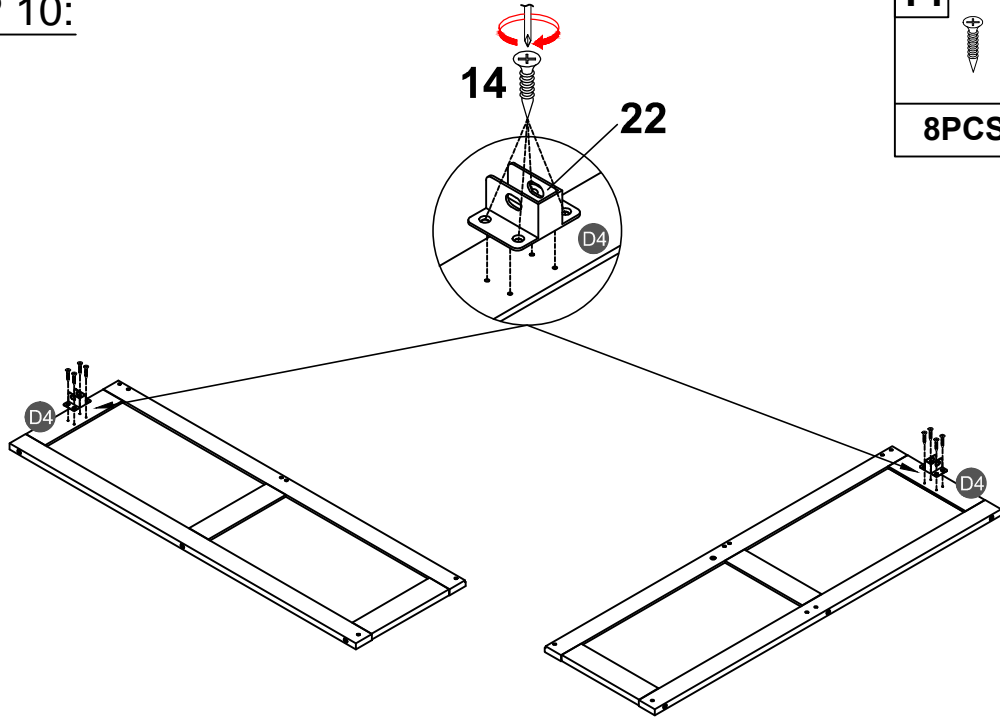

14		22	
8PCS		2PCS	

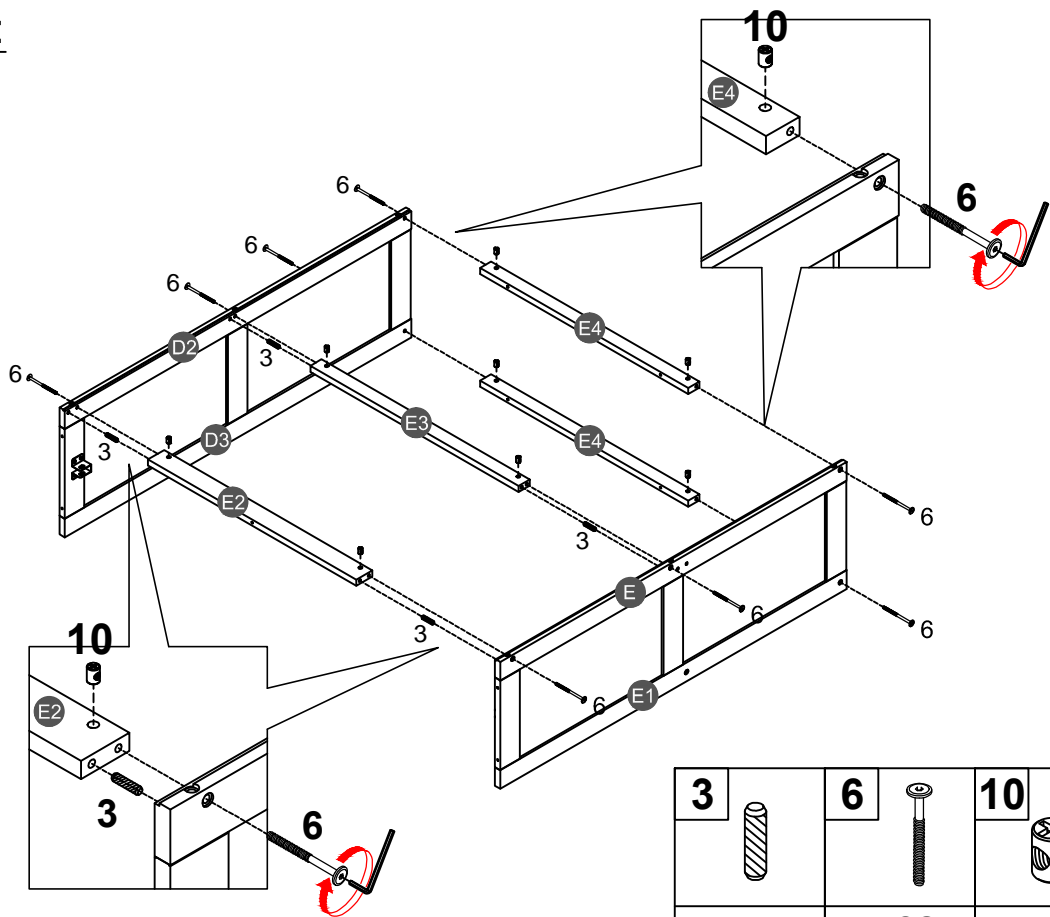

STEP 11:

ÉTAPE



3		6		10	
4PCS		8PCS		8PCS	

STEP 12:

ÉTAPE

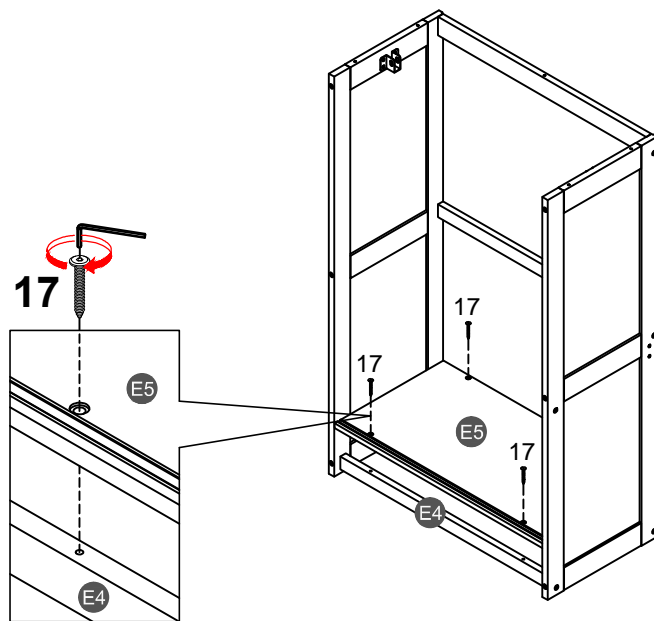



17	
4PCS	

STEP 13:

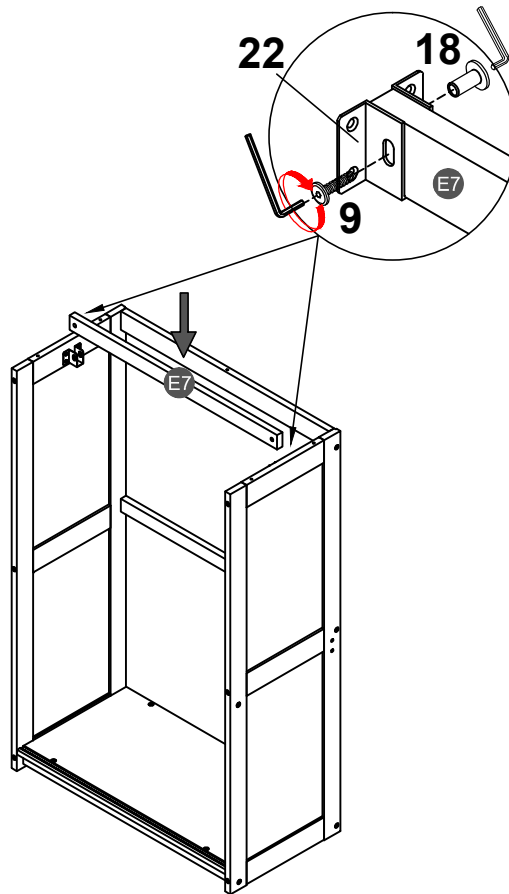
ÉTAPE



9	18
	
2PCS	2PCS

STEP 14:

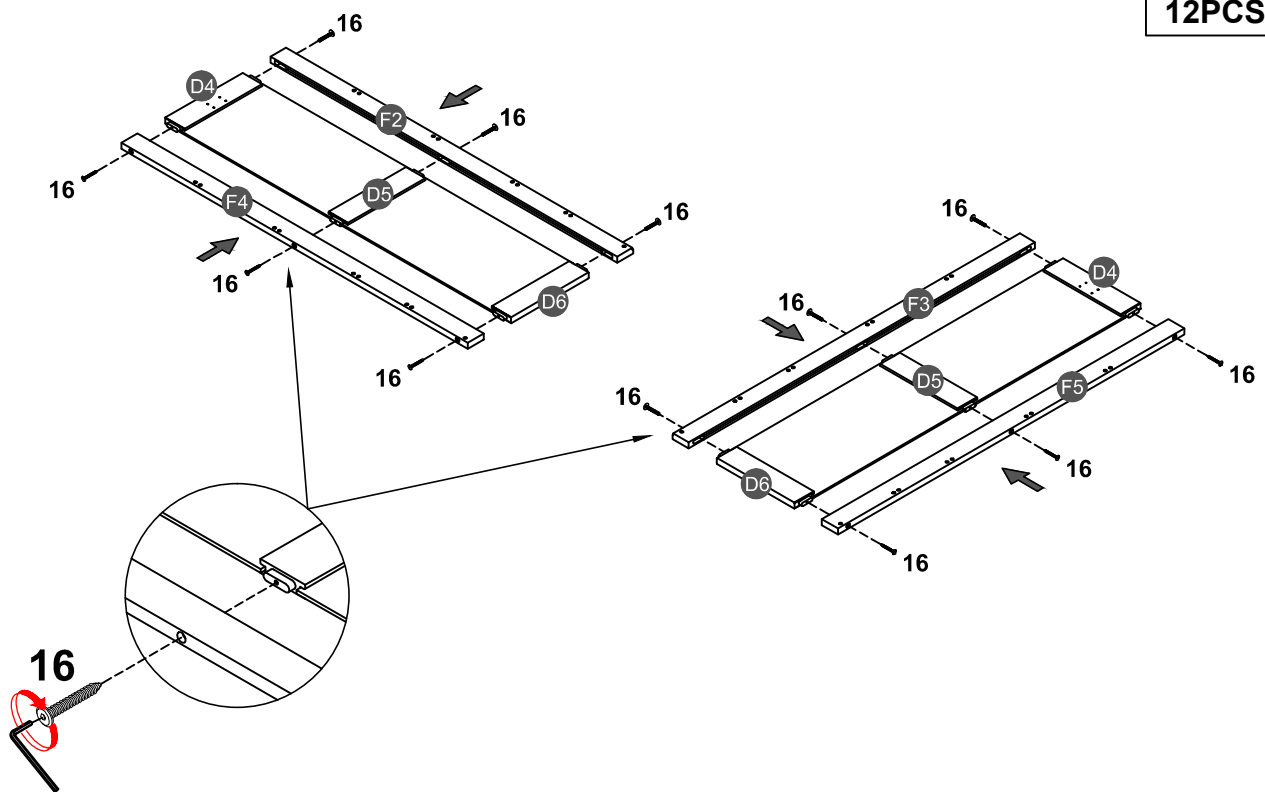

ÉTAPE

16

12PCS



STEP 15:

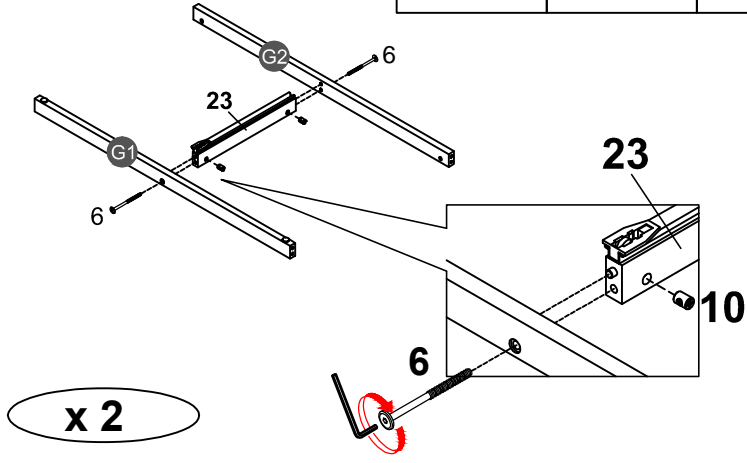

ÉTAPE

6		10		23	
4PCS		4PCS		2PCS	



STEP 16:

ÉTAPE

3		6		10	
16PCS		18PCS		18PCS	

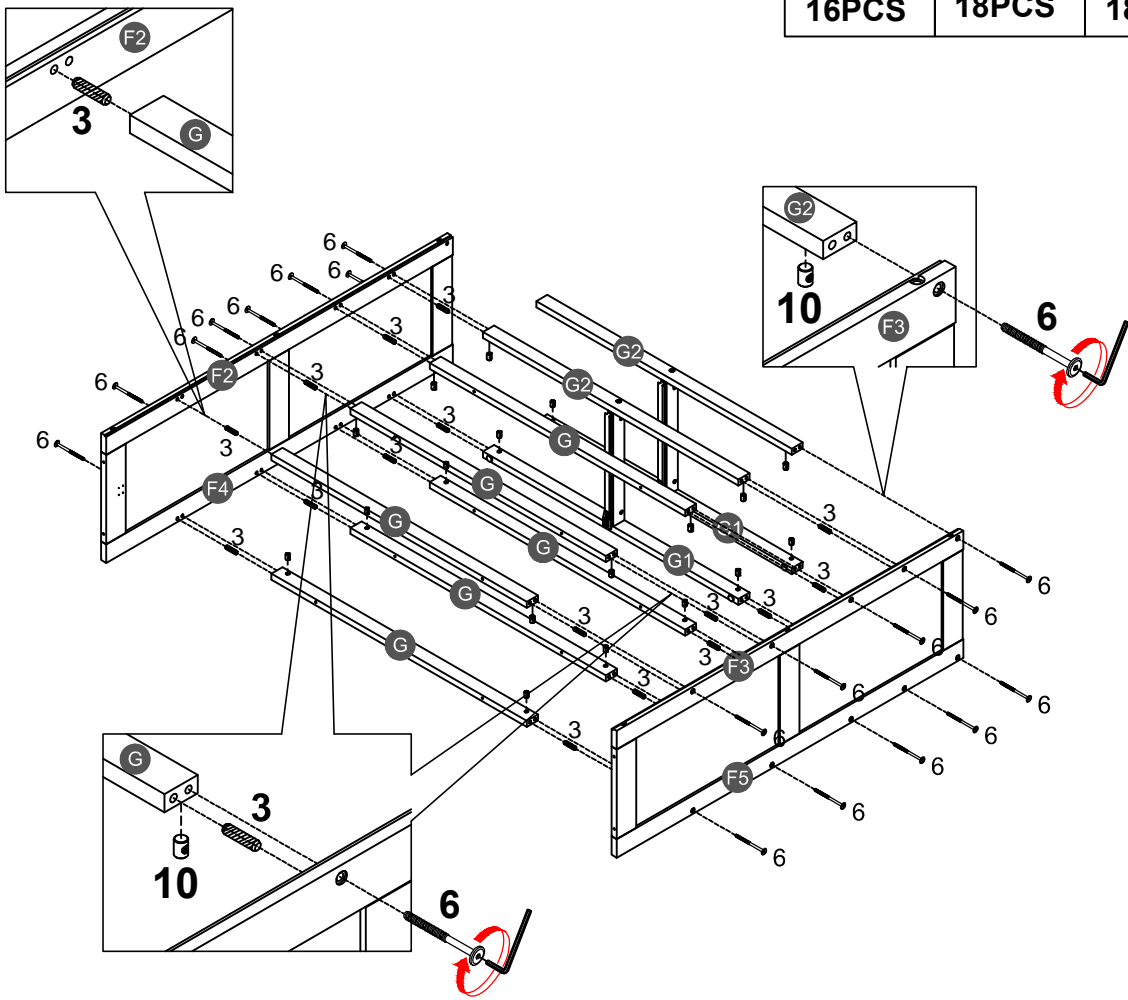

STEP 17:

ÉTAPE

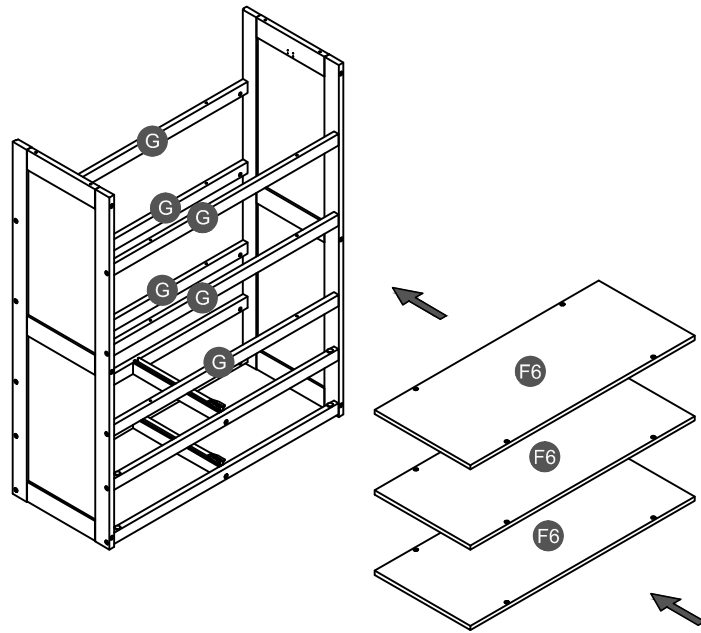

STEP 18:

ÉTAPE

17



12PCS

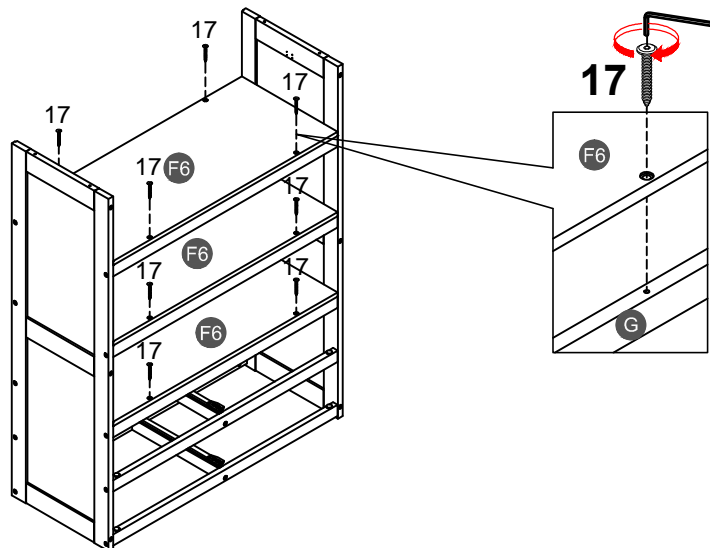

STEP 19:

ÉTAPE

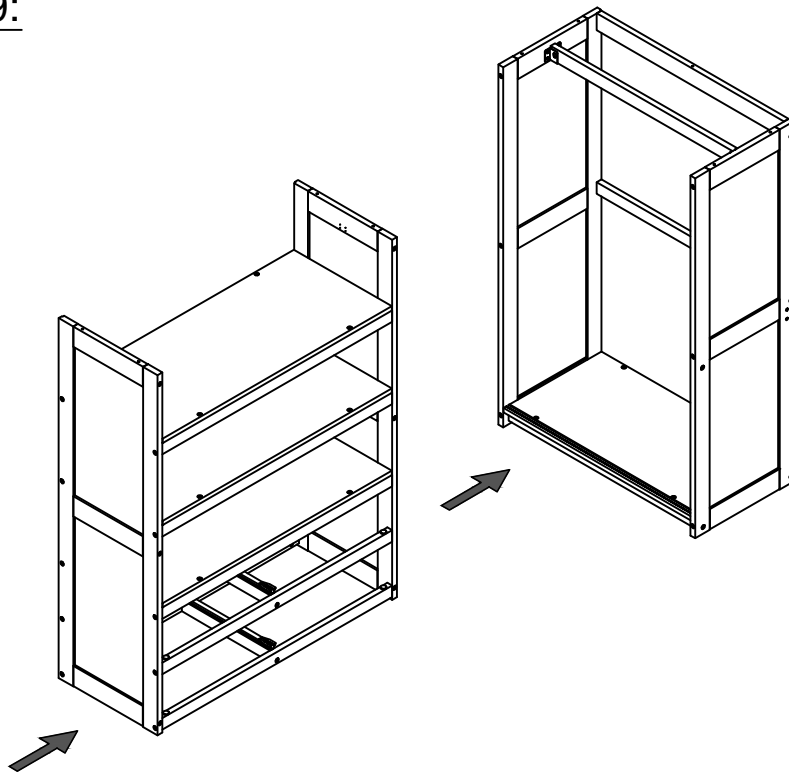

STEP 20:

ÉTAPE

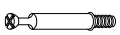
16		25	
2PCS		1PC	

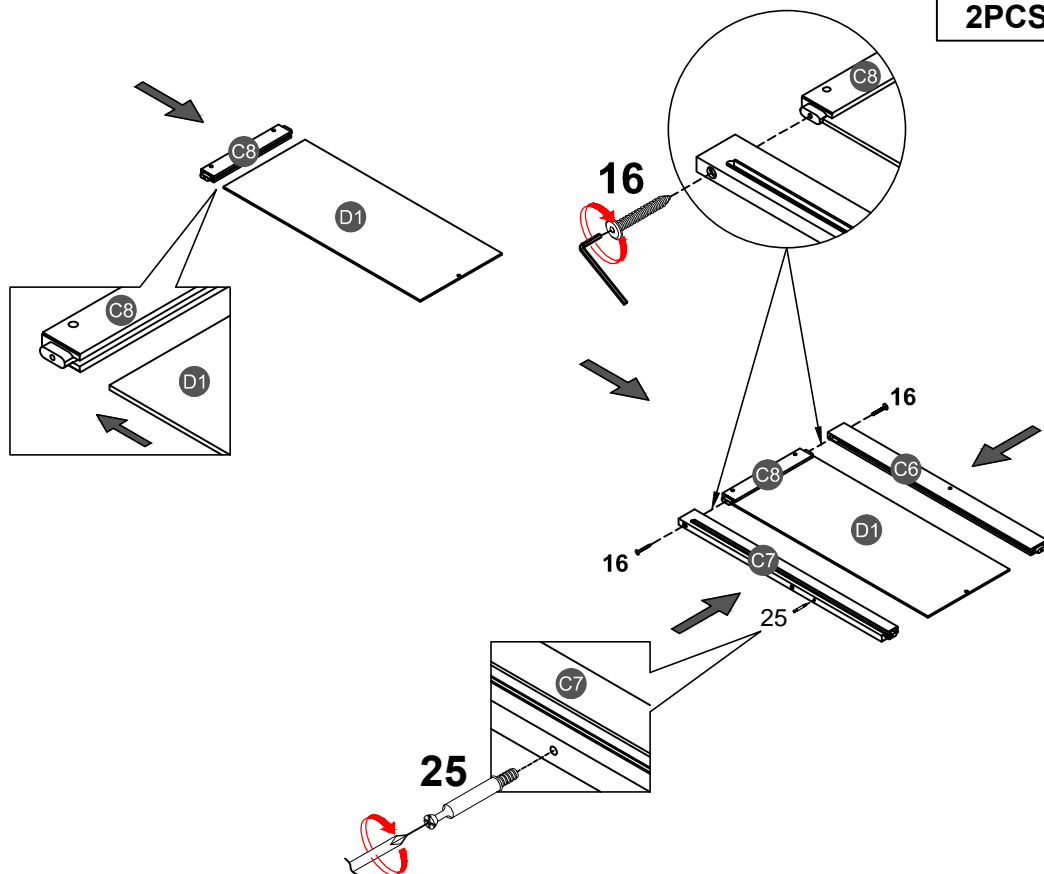

STEP 21:

ÉTAPE

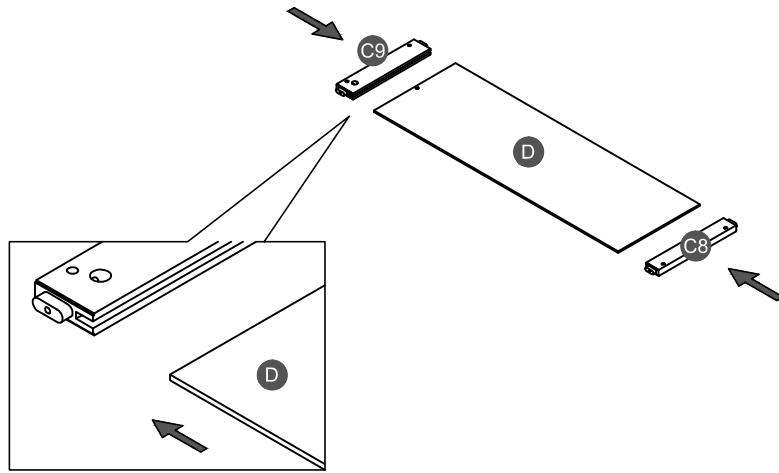

STEP 22:

ÉTAPE

16



2PCS

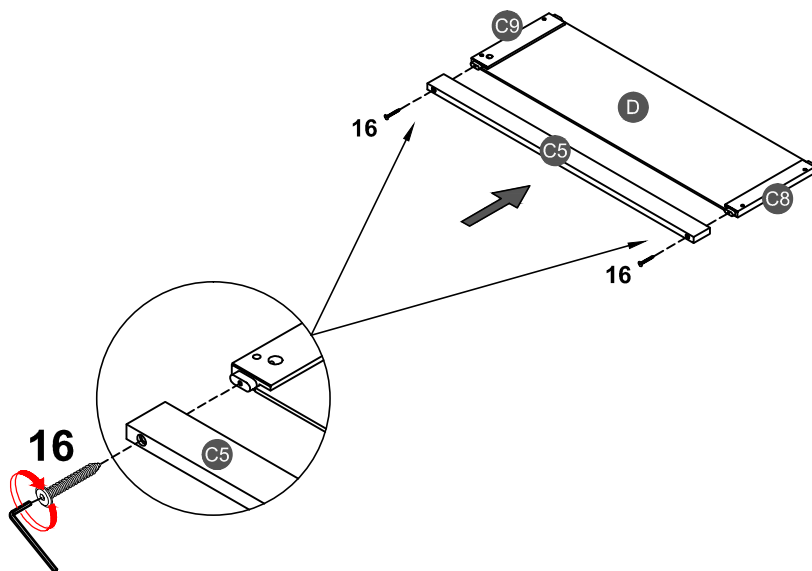

STEP 23:

ÉTAPE

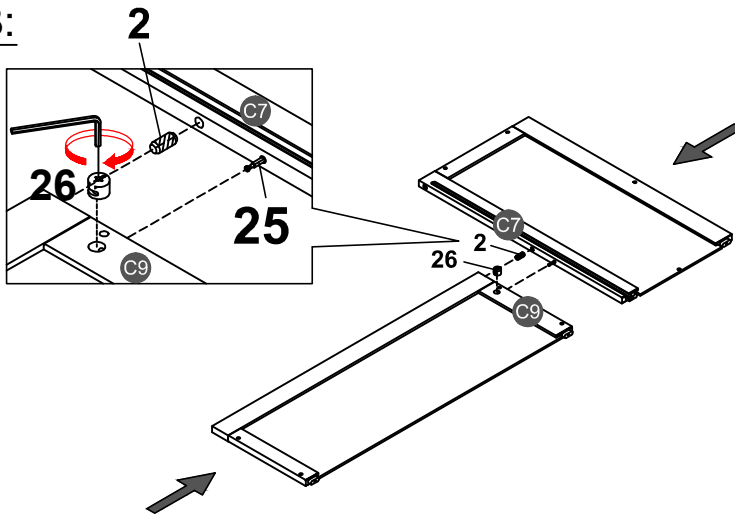

2	26
1PC	1PC

Note: Place hardware #26 with the "X" face outward, and make sure that the arrowhead is upward. Then, place hardware #26 into the hole of hardware #25 and tighten it clockwise with a hand screwdriver. (Please do NOT use an electric screwdriver.)

Remarque : placez la quincaillerie #26 avec la face « X » vers l'extérieur, et assurez-vous que la pointe de la flèche est vers le haut. Ensuite, placez le matériel #26 dans le trou de la quincaillerie #25 et serrez-le dans le sens des aiguilles d'une montre avec un tournevis à main. (Veuillez ne PAS utiliser de tournevis électrique.)

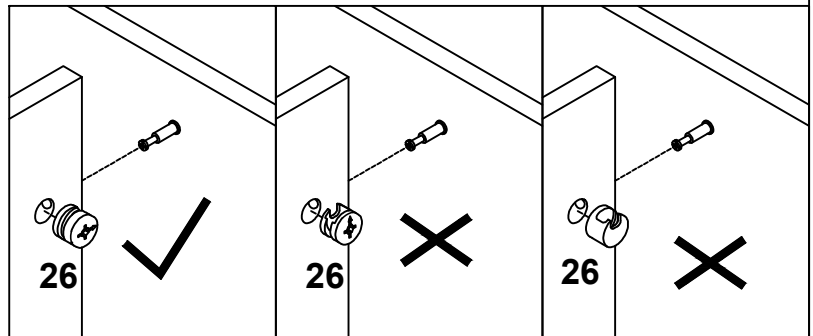

STEP 24:

ÉTAPE

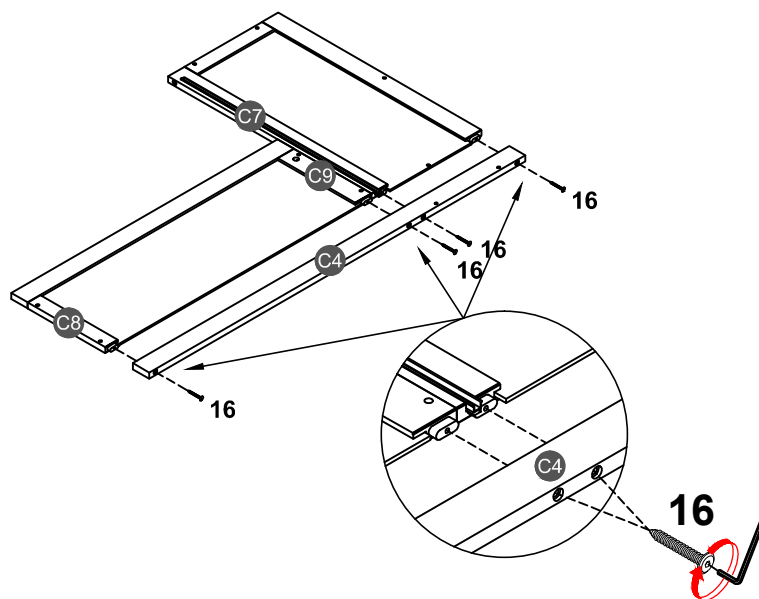

16
4PCS

STEP 25:

ÉTAPE

17



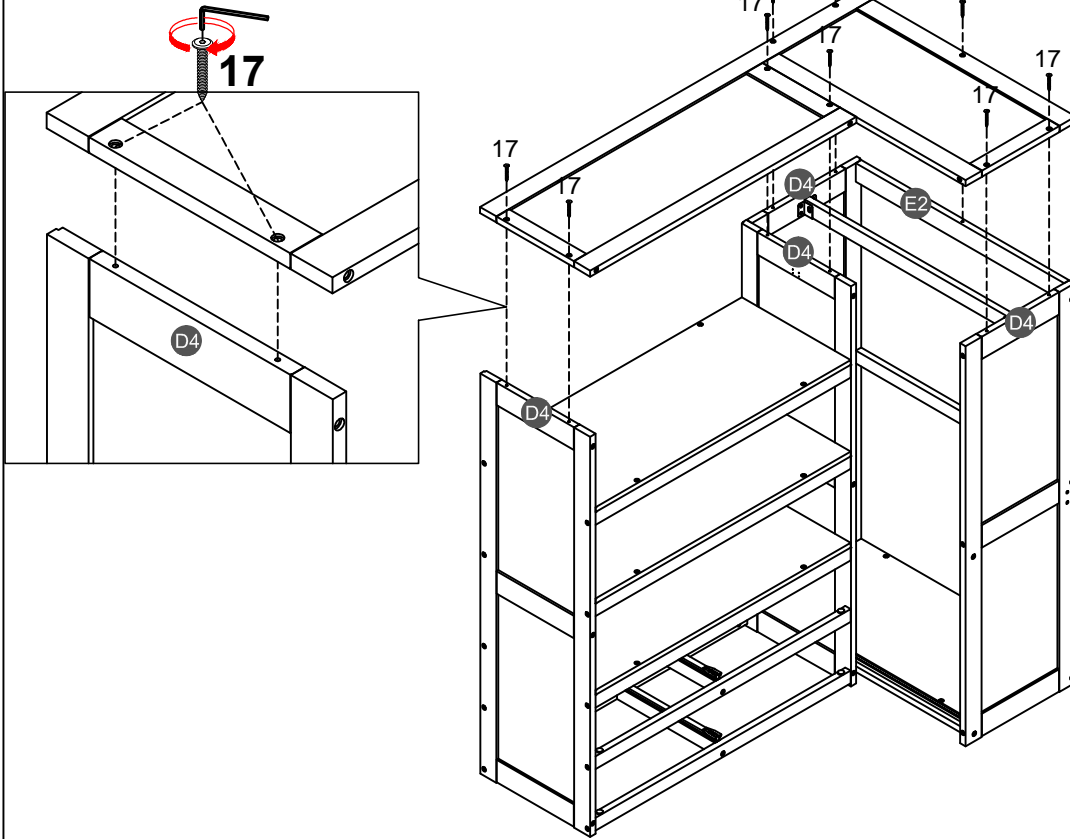

9PCS

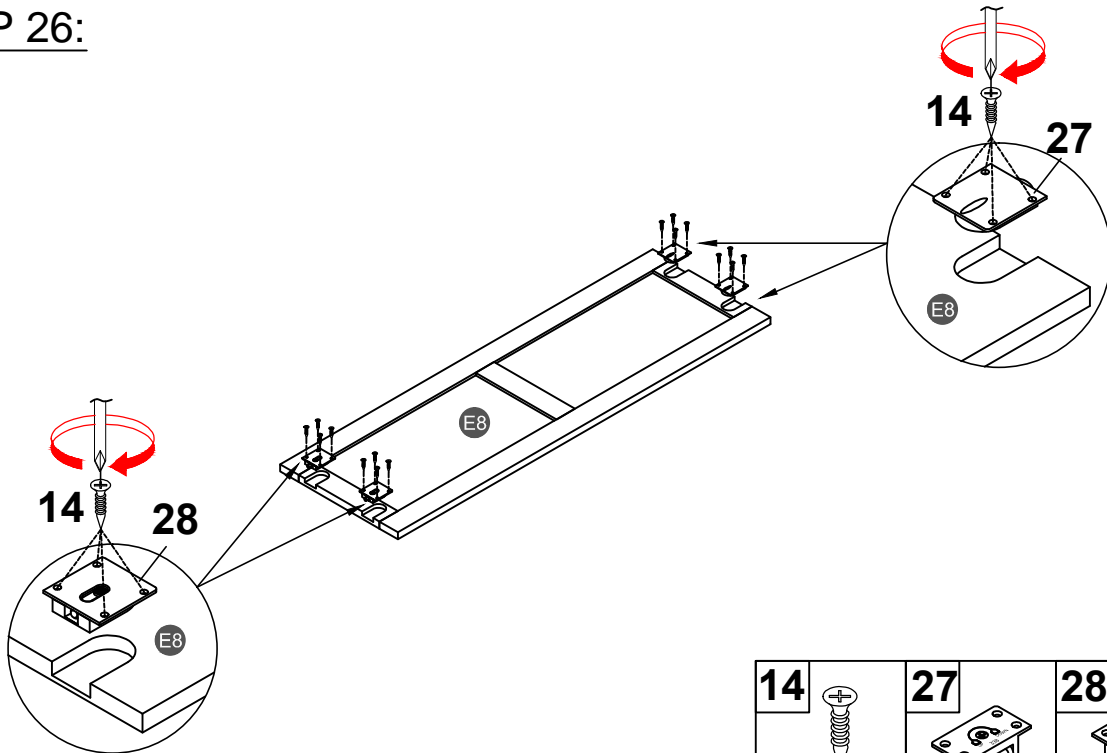

STEP 26:

ÉTAPE

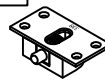

14	27	28
		
16PCS	2PCS	2PCS

STEP 27:

ÉTAPE

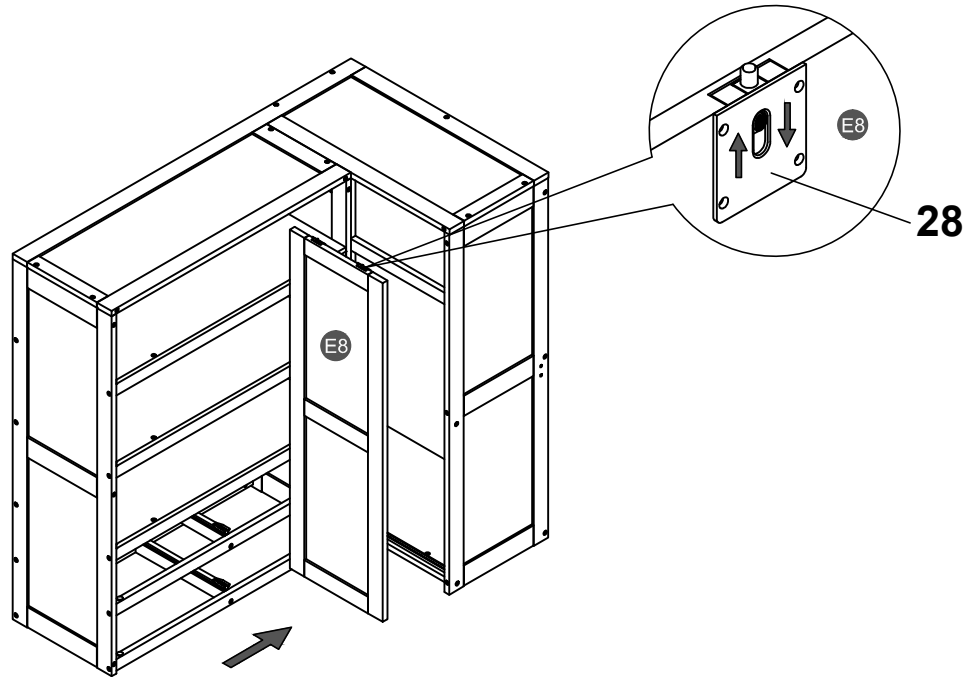

STEP 28:

ÉTAPE

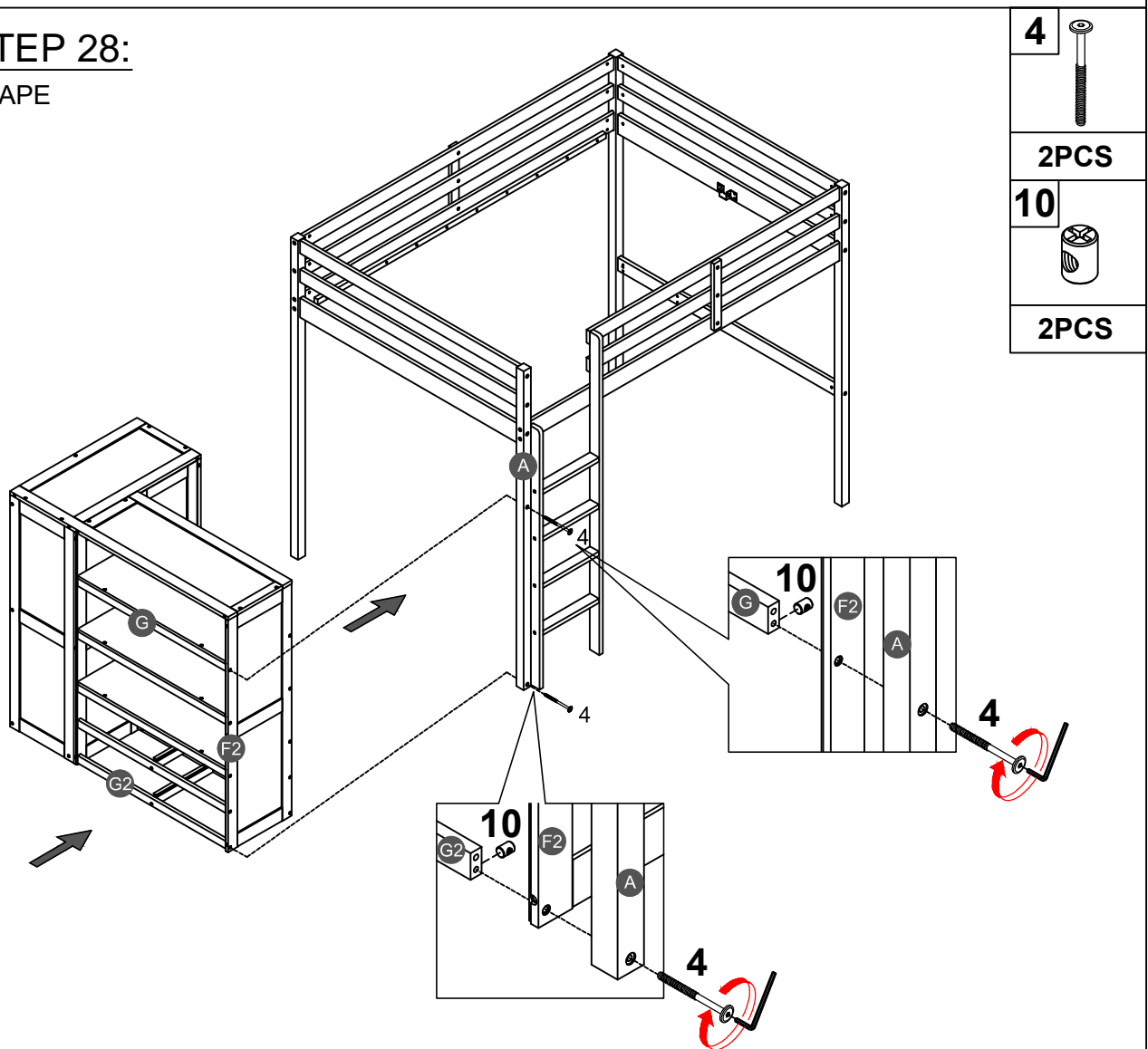

STEP 29:

ÉTAPE

25

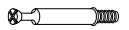

4PCS

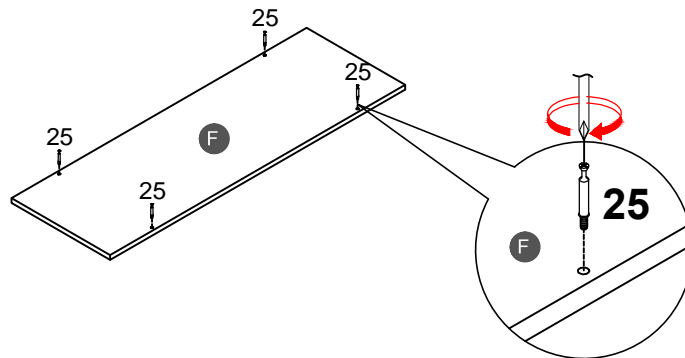

STEP 30:

ÉTAPE

6



4PCS

10



4PCS

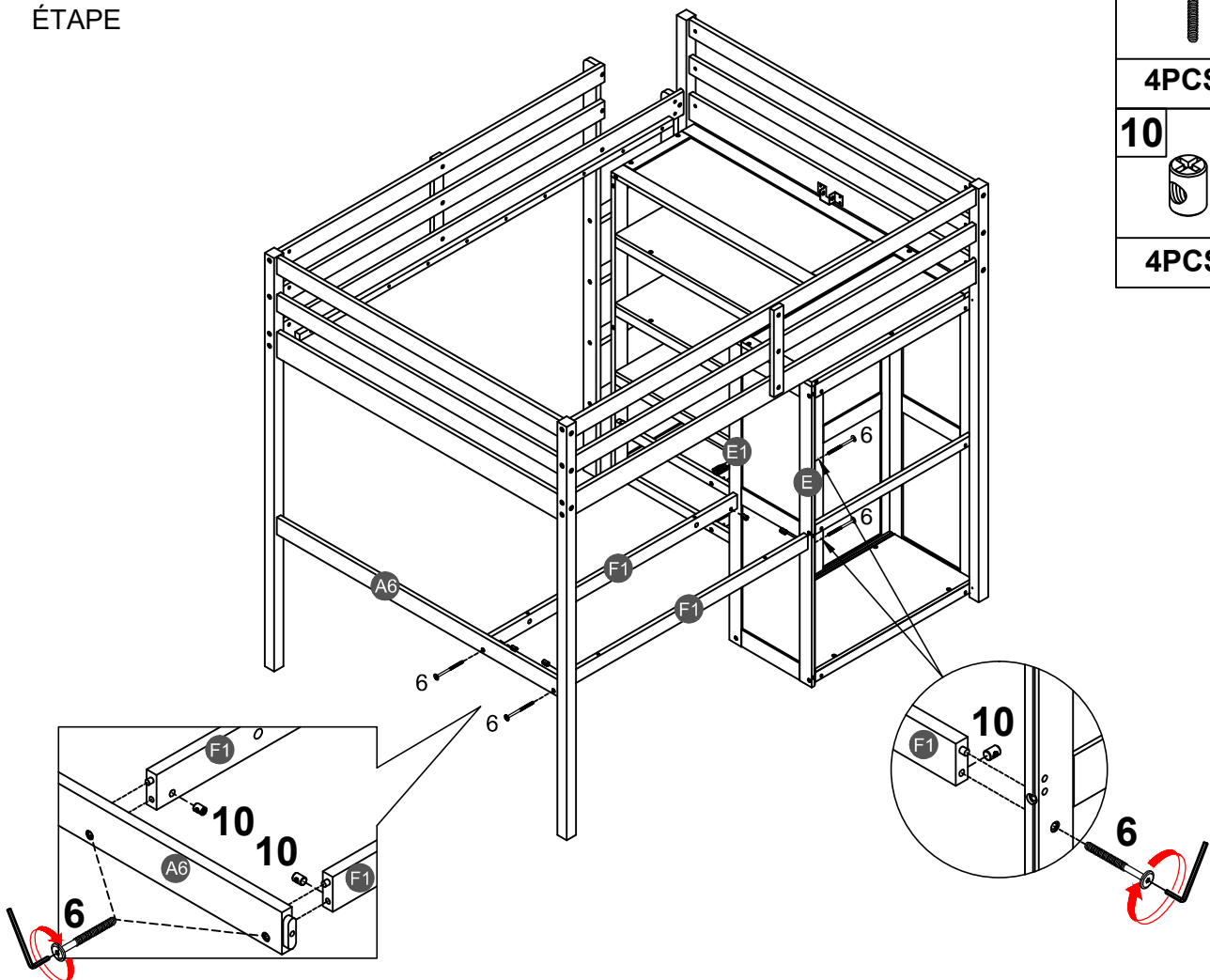

STEP 31:

ÉTAPE

26



4PCS

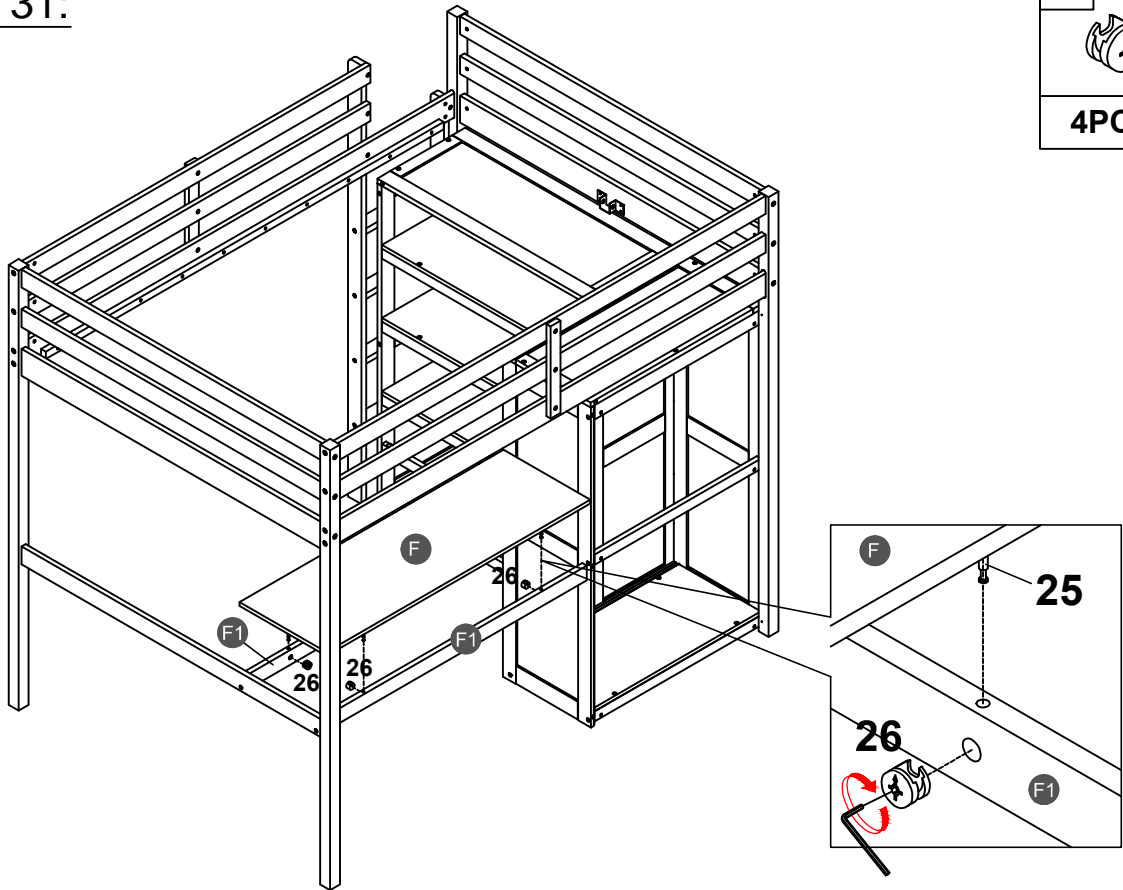

STEP 32:

ÉTAPE

15



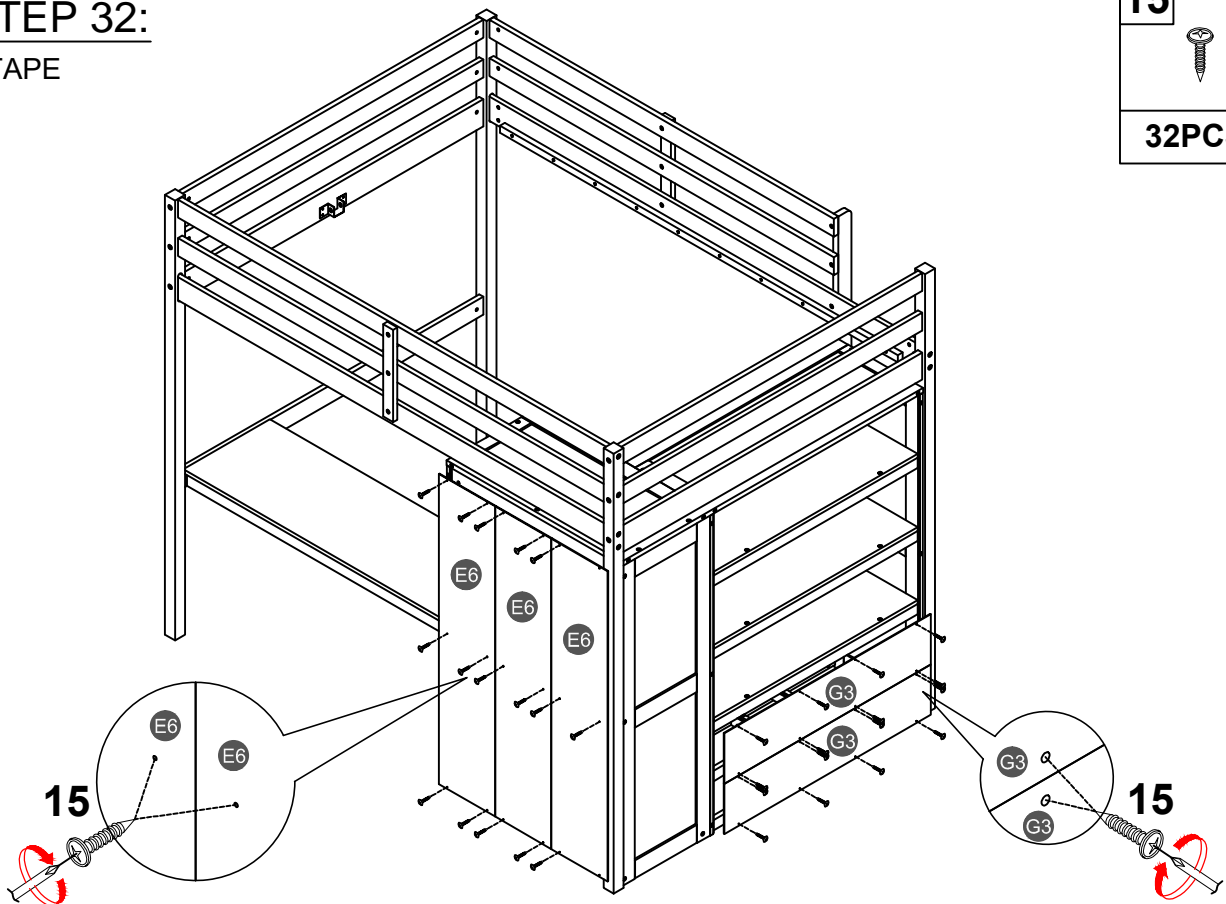

32PCS



STEP 33:

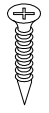

ÉTAPE

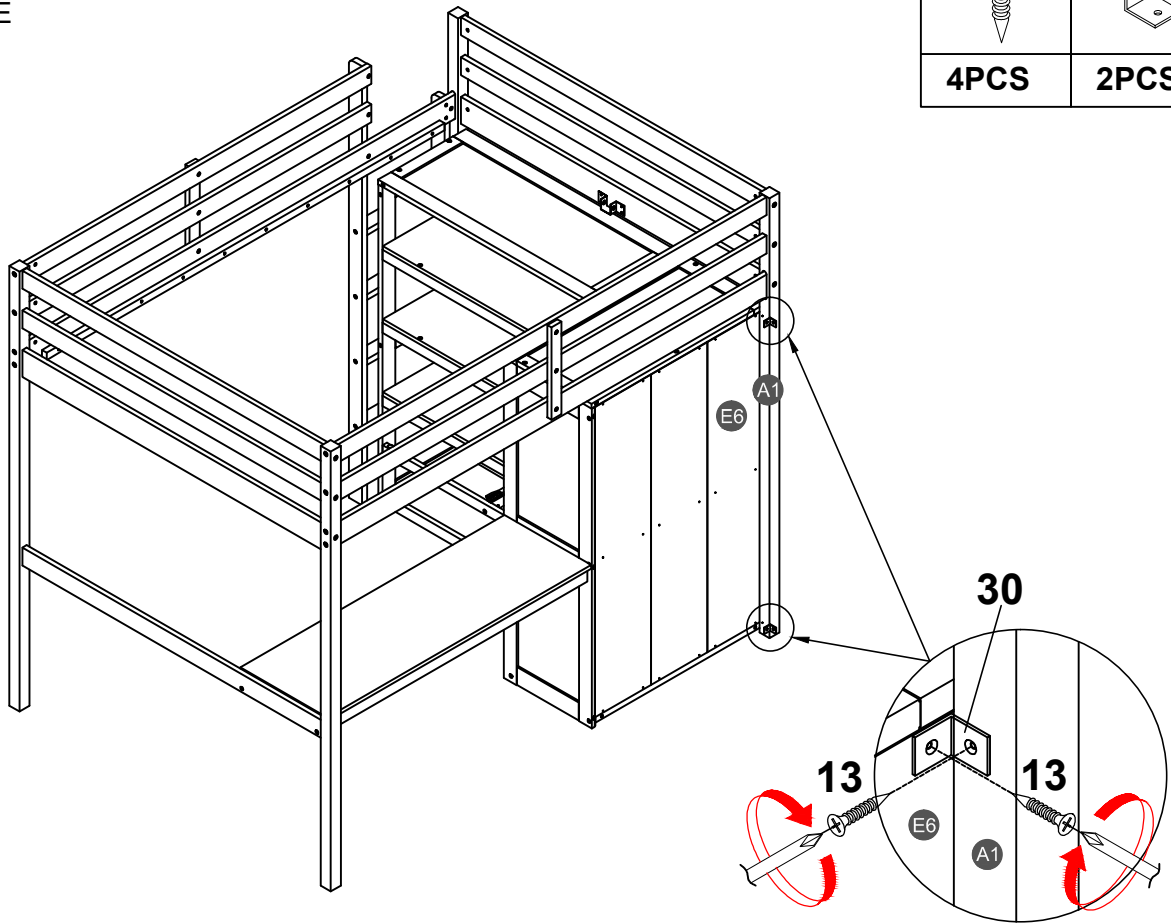
13		30	
4PCS		2PCS	



STEP 34:

ÉTAPE

3		6	
8PCS		4PCS	
		10	
		4PCS	

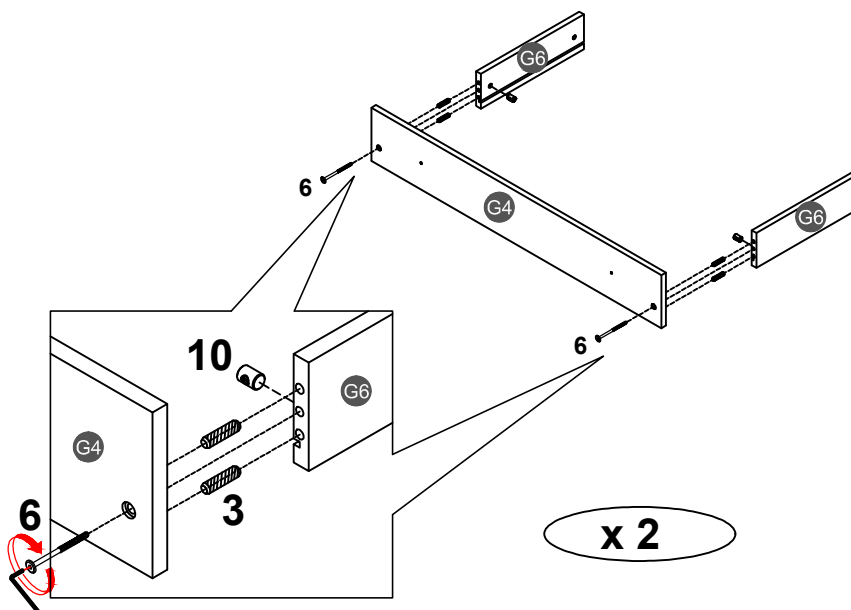

STEP 35:

ÉTAPE

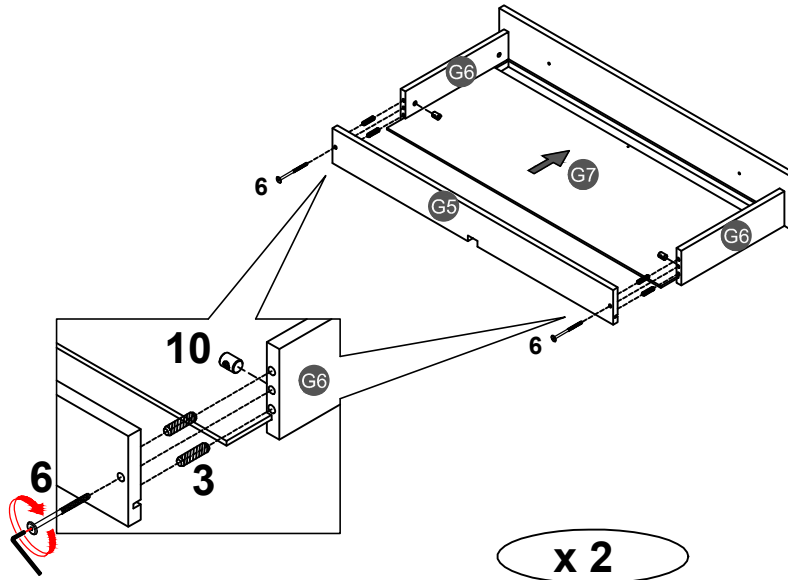

3		6	
8PCS		4PCS	
		10	
		4PCS	

STEP 36:

ÉTAPE

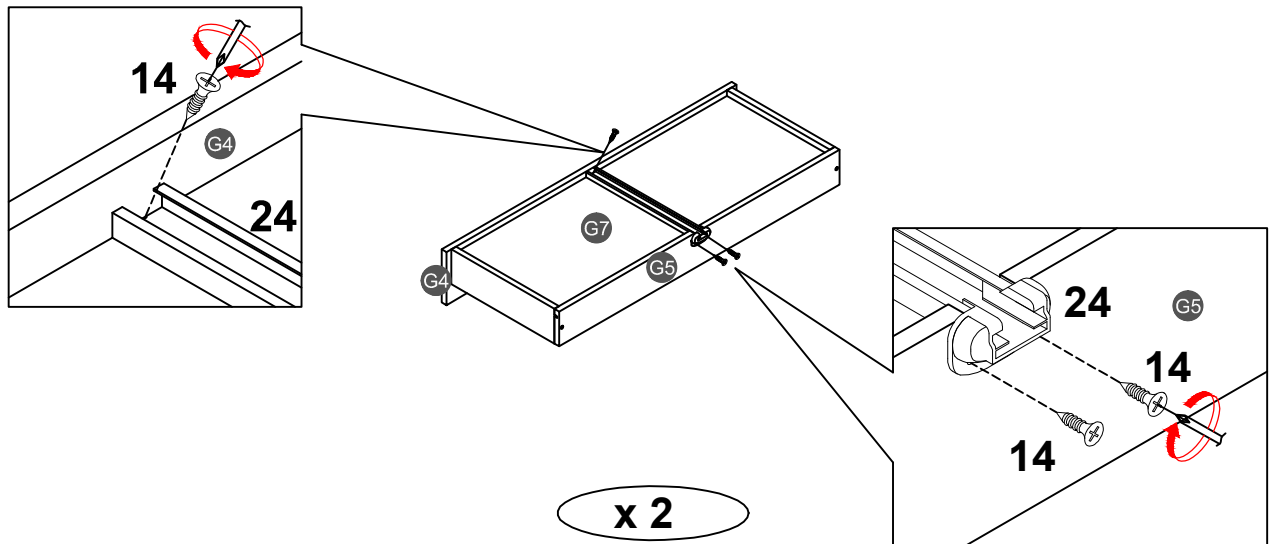

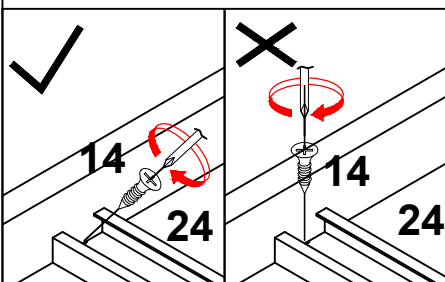

14		24	
6PCS		2PCS	



STEP 39:

ÉTAPE

7		18	
2PCS		2PCS	

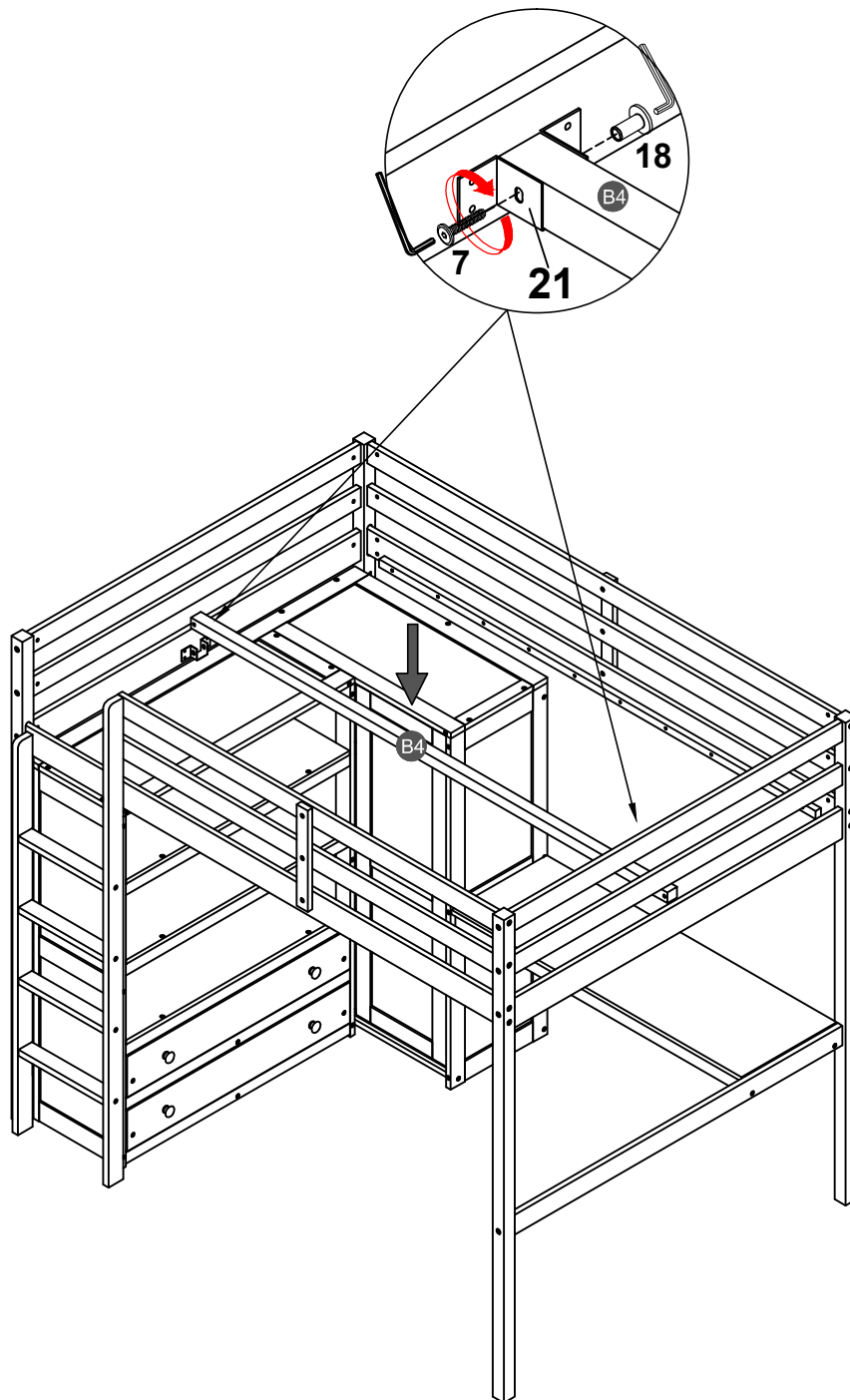

STEP 40:

ÉTAPE

11



32PCS

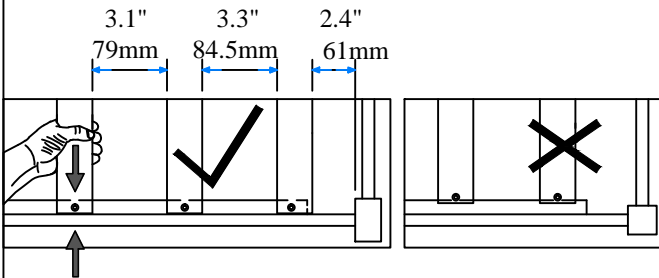
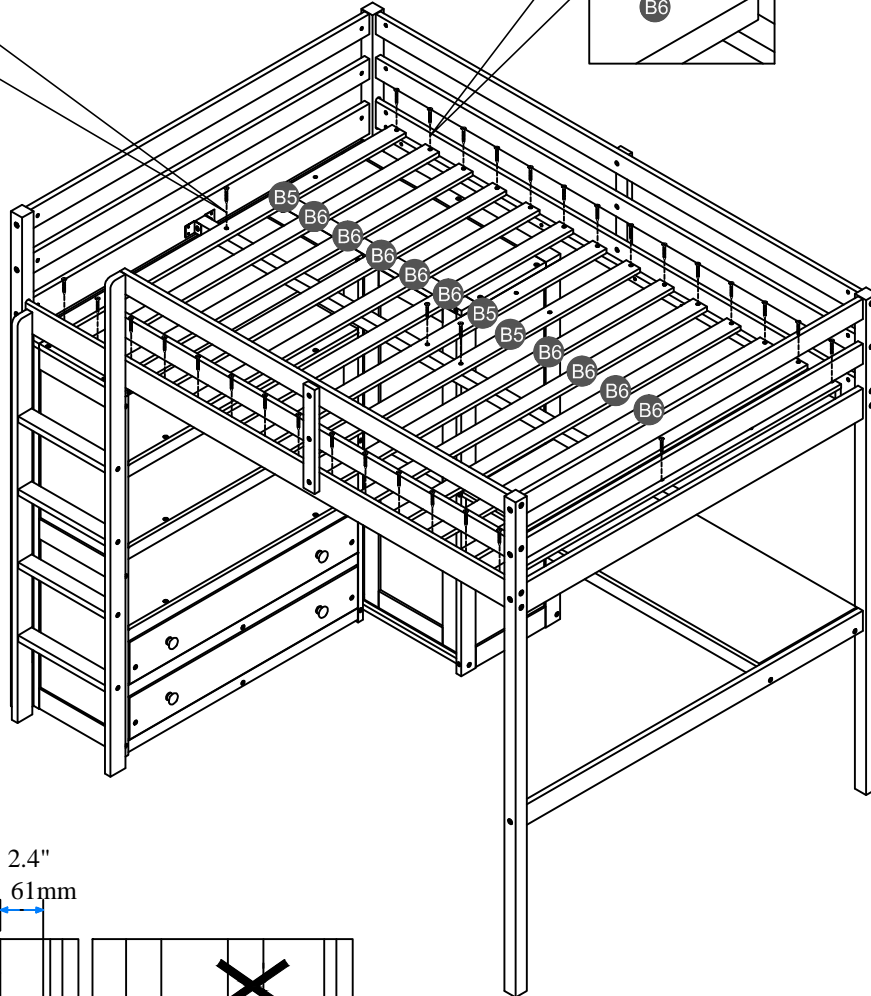
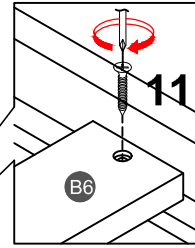
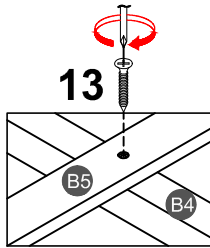

NOTE: Please make sure the bed slats close to the side rail before locking the screws to avoid breakage. This step is required for both the left and right sides. Moreover, please do not lock the screws of the bed slats at the outermost edge to avoid damaging.

Remarque: Assurez-vous Les lattes du lit fermer du rail latéral avant de verrouiller les vis pour éviter la casse. Cette étape est requise pour tous les deux côtés gauche et droit. De plus, ne verrouillez pas les vis des lattes de lit sur le bord le plus extérieur pour éviter d'endommager.

Make sure to tighten all the screws of the bed.

Assurez-vous de serrer toutes les vis des de lit.