

Assembly Instructions



Caution : You must read this before you proceed

Table









Part List

Label	Picture	Description	QTY
A	A line drawing of a rectangular table top, showing its thickness and slightly tapered edges.	Table Top	1

B		Table Leg	4
C		Support	4

Hardware

Label	Picture	Description	QTY
①		Bolt (M6 x 35mm)	5
②		Bolt (M6 x 60mm)	9
③		Screw (M4 x 20mm)	5
④		Spring Washer	13
⑤		Washer	9
⑥		Allen Key	1
⑦		Screwdriver (Not provided)	1

Assembly Preparation

Before
Beginning
Assembly:

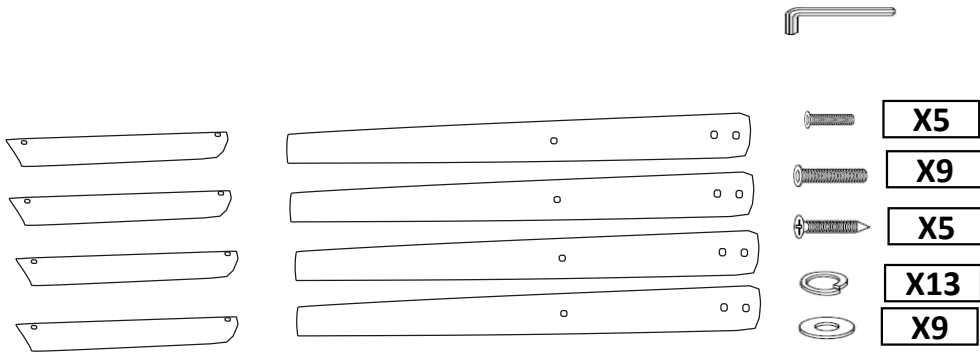
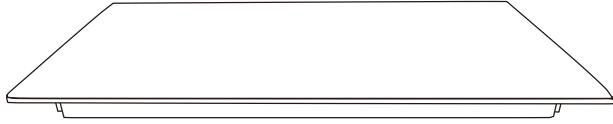

- Read instructions, cover to cover-



- Have 2 adults on hand for assembly-



- Do not assemble on flooring or carpet-



- Assemble on a clean non-marring surface (packing foam)-



- Save all packaging until finished-

Assembly Steps

Overview

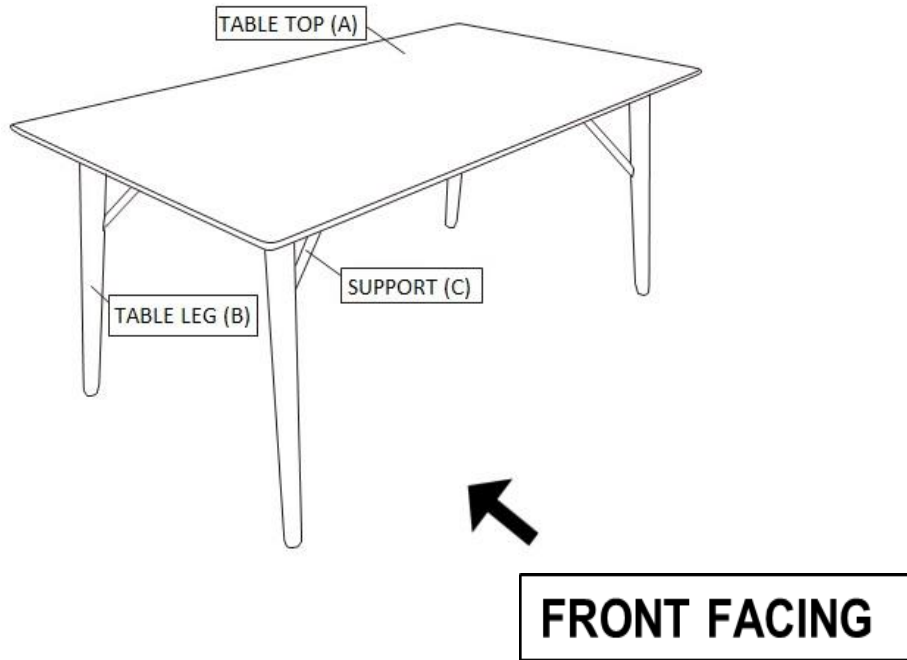

This Table has multiple parts and may require up to 30 minutes to assemble. To give you an overview of the Table parts, the above picture is to help you put the various parts into perspective. Please read through the instructions below to familiarise yourself with the parts and steps before assembly.

Step 1

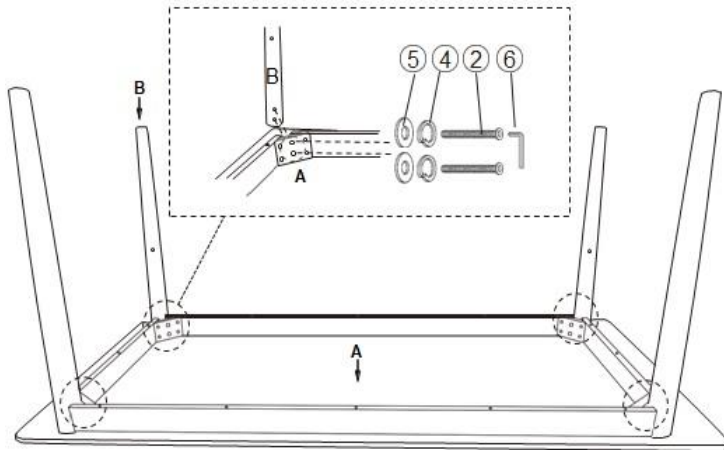

Place the Table Top(A) facedown on a clean, non-marring surface.
Insert the Table Legs(B) into the Table Top(A) and attach using Bolts(2), Spring Washers(4) and Washers(5) with Allen Key(6).
Do not fully tighten the Bolts until all parts has been completed installed.

Step 2

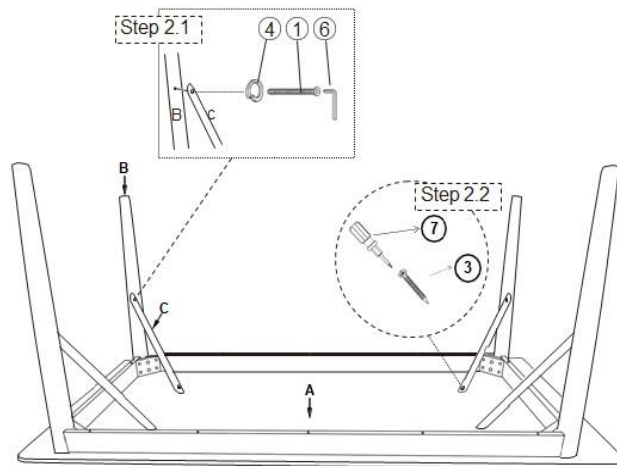

2.1) Attach the Support(C) to Table Leg(B) using Bolts(1), Spring Washers(4) and Washers(5) with Allen Key(6).
2.2) Attach the Support(C) to Table Top(A) using Screws(3)with Screwdriver(7).
Do not fully tighten the Bolts or Screws.

Step 3

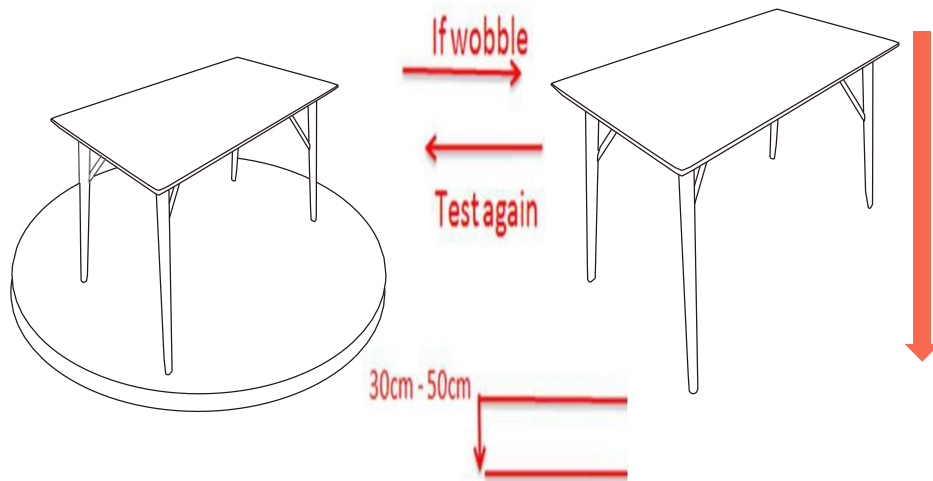

Place the Table on a LEVEL SURFACE to see if it wobbles.

If it wobbles, lift the Table some 30cm to 50cm high from the ground.

Keep your feet and toes well away from the drop zone.

Drop the product freely and vertically with the four legs, hitting the ground, at the same time.

This Drop Test will help to ensure that all parts and gaps reach full alignment status.

Test again for evenness on a LEVEL SURFACE.

If no wobbles found, proceed to tighten all the Bolts and Screws at all joints.

When tightening the Bolts and Screws, tighten sequentially.

DO NOT tighten any Bolt or Screw fully and then move on towards the next one.

This would cause the frame to warp.

If there is still wobbles, loosen the Bolts and execute this same drop test.







Step 4



Your Table is ready for use

This Table can only be used on a flat, level surface.

Care & Maintenance

- ⊘  ● Do not put hot items directly on furniture surface
- ⊘  ● Do not clean furniture with harsh cleansers or polish.
- ⊘  ● Do not place furniture under direct sunlight.
- ⊘  ● Do not place furniture near heating or cooling vents.
- ⊘  ● Do not write on furniture without a padded barrier to protect the surface.
- ⊘  ● Do not place furniture outside . For indoor use only .
- ⊘  ● Not for commercial use. For residential use only .
- ⊘  ● Stains may be removed with mild soap solution and damp cloth.
- ⊘  ● Children should not climb or jump on the furniture.

-
- ✓  ● Dust and pick-up spills using a clean, non-colored, lint-free cloth .