

SKU Number:CM2905(2025A)

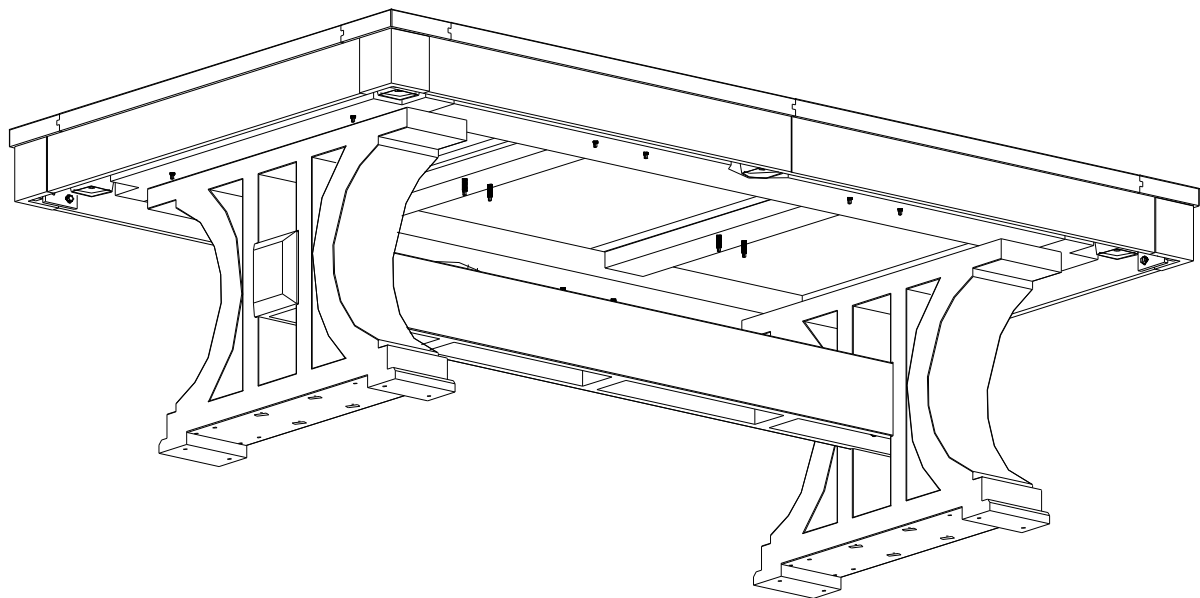

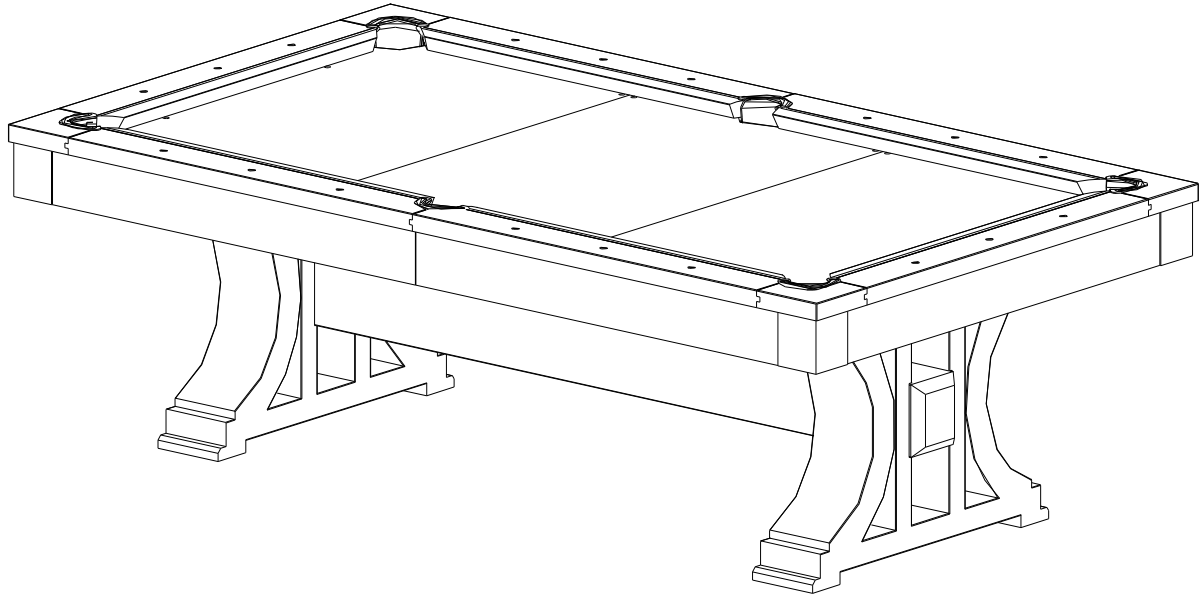





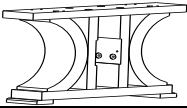

## SLATE POOL TABLE

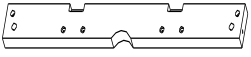
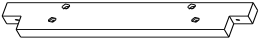

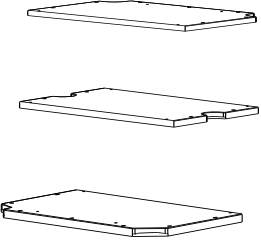
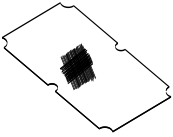
**WARNING: Do not attempt to assemble the pool table if any parts are missing or damaged.** Improper assembly may lead to damage or serious injury! We strongly recommend using [thumbtack.com](https://thumbtack.com) or Google to locate local billiard stores with professionals experienced in assembling pool tables instead of relying on the provided "professional" general furniture assembly service(For example of Angi). Slate leveling and attaching the felt require expertise beyond typical furniture installation.Regular installations typically require the assistance of two or more adults.

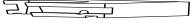

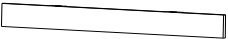
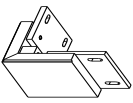







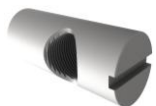
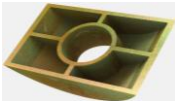

Please read the following instructions carefully prior to assembly.Check the parts list to make sure you have all the parts needed for proper assembly.

### PARTS LIST (1)

NO.	IMAGE	DESCRIPTION	SPECIFICATION(mm)	QTY	UNIT
A		Table Leg	980*190*660	2	PCS
		ASSEMBLY POSITION	FRAME		
B		Leg Panel	2133*180*160	1	PCS
		ASSEMBLY POSITION	FRAME		
C		Long Beam	1936*180*65	2	PCS
		ASSEMBLY POSITION	FRAME		
D		Support Beam	1173*180*65	2	PCS
		ASSEMBLY POSITION	FRAME		
E		Middle Beam	893*120*40	2	PCS
		ASSEMBLY POSITION	FRAME		
F		SIDE SLATE 1	804*1295*40	1	PCS
		ASSEMBLY POSITION	TOP RAIL		
		MIDDLE SLATE	804*1295*40	1	PCS
		ASSEMBLY POSITION	TOP RAIL		
		SIDE SLATE 2	804*1295*40	1	PCS
ASSEMBLY POSITION	TOP RAIL				
G		Big Felt for Slate Bed (G1)	2500*1450	1	PCS
		Small Felt for Cushion Rails (G2)	1250*160	6	PCS
		ASSEMBLY POSITION	SLATE BED + TOP RAIL		
H		#1&#4 END RAIL	1083*164*43	2	PCS
		ASSEMBLY POSITION	TOP RAIL		
I		TOP RAIL CORNER	190*190*43	4	PCS
		ASSEMBLY POSITION	TOP RAIL		
J		#3&#6 SIDE RAIL	1101*164*43	2	PCS
		ASSEMBLY POSITION	TOP RAIL		
K		#2&#5 SIDE RAIL	1111*164*43	2	PCS
		ASSEMBLY POSITION	TOP RAIL		
L		Short Panel	1183*140*50	2	PCS
		ASSEMBLY POSITION	TOP RAIL		
M		Apron Corner	170*170*140	4	PCS
		ASSEMBLY POSITION	TOP RAIL		
N		Long Panel	2302*140*50	2	PCS
		ASSEMBLY POSITION	TOP RAIL		

## PARTS LIST ( 2 )

	NO.	IMAGE	DESCRIPTION	SPECIFICATION(mm)	QTY	UNIT	
Step ①	H1		HEX BOLT	ø10*45	8	PCS	
			FOR TABLE LEG AND PANEL				
①	H2		FLAT WASHER	M10*30*2	8	PCS	
			FOR TABLE LEG AND PANEL				ASSEMBLY POSITION
Step ②	H3		HEX BOLT	ø12*180	4	PCS	
			FOR CROSS BEAM				ASSEMBLY POSITION
	H4		FLAT WASHER	M12*30*2	4	PCS	
			FOR CROSS BEAM				ASSEMBLY POSITION
	②	H5		SEMICIRCLE SCREW NUT	M12	4	PCS
				FOR CROSS BEAM			
H6		FLAT HEAD SCREW	4.2*60	8	PCS		
		FOR MIDDLE CROSS BEAM				ASSEMBLY POSITION	
Step ③	H7		HEXAGON BOLT	ø10*70	8	PCS	
			FOR BASED FRAME AND TABLE LEG				ASSEMBLY POSITION
③	H2		FLAT WASHER	M10*30*2	8	PCS	
			FOR BASED FRAME AND TABLE LEG				ASSEMBLY POSITION
Step ④	H8		SLATE LEVELER	ø10*75	16	PCS	
			TO ADJUST THE SLATE				ASSEMBLY POSITION
Step ⑤	H9		RUBBER TABLE LEG SHIM	2mm*2pcs 3mm*2pcs	4	PCS	
			TO ADJUST THE TABLE LEG				ASSEMBLY POSITION
Step ⑥	H10		WOODEN SCREW	6*60	12	PCS	
			FOR SLATE AND TABLE FRAME				ASSEMBLY POSITION

Step ⑧	H11		wood plug	ø10*50	2	PCS
			FOR #2、#3、#5、#6 SIDE RAIL			
	H12		BARREL NUT	M8*30	8	PCS
			FOR THE LONG AND SHORT RAIL			
	H13		SEMICIRCLE WASHER	M8	8	PCS
FOR TOP RAIL AND RAIL CORNER				ASSEMBLY POSITION		
H14		FLAT WASHER	M8*25*1	8	PCS	
		PLEASE SEE THE INSTRUCTION				ASSEMBLY POSITION
H15		HEX BOLT	ø8*80	8	PCS	
		FOR TOP RAIL AND RAIL CORNER				ASSEMBLY POSITION
Step ⑨	H16		HEX BOLT	ø8*25	16	PCS
			FOR APRON AND APRON CORNER			
H14		FLAT WASHER	M8*25*1	16	PCS	
		FOR APRON AND APRON CORNER				ASSEMBLY POSITION
Step ⑩	H17		HEX BOLT	ø8*40	12	PCS
			FOR APRON AND APRON CORNER			
H14		FLAT WASHER	M8*25*1	12	PCS	
		FOR APRON AND APRON CORNER				ASSEMBLY POSITION
Step ⑪	H18		HEX BOLT	ø10*60	18	PCS
			USED TO CONNECT THE TOP RAILS AND SLATE			
H19		DOME WASHER	M10*36*5	18	PCS	
		USED TO CONNECT THE TOP RAILS AND SLATE				ASSEMBLY POSITION
Step ⑫	H20		CORNER POCKET	/	4	PCS
H21		SIDE POCKET	/	2	PCS	
						ASSEMBLY POSITION
H22		FLAT HEAD SCREW	4.2*16	12	PCS	
		FOR POCKET BOTTOM STRIPS AND SLATE BACKER				ASSEMBLY POSITION
H23		STEEL NAIL	/	12	PCS	
		FOR POCKET BOTTOM STRIPS AND SLATE BACKER				ASSEMBLY POSITION

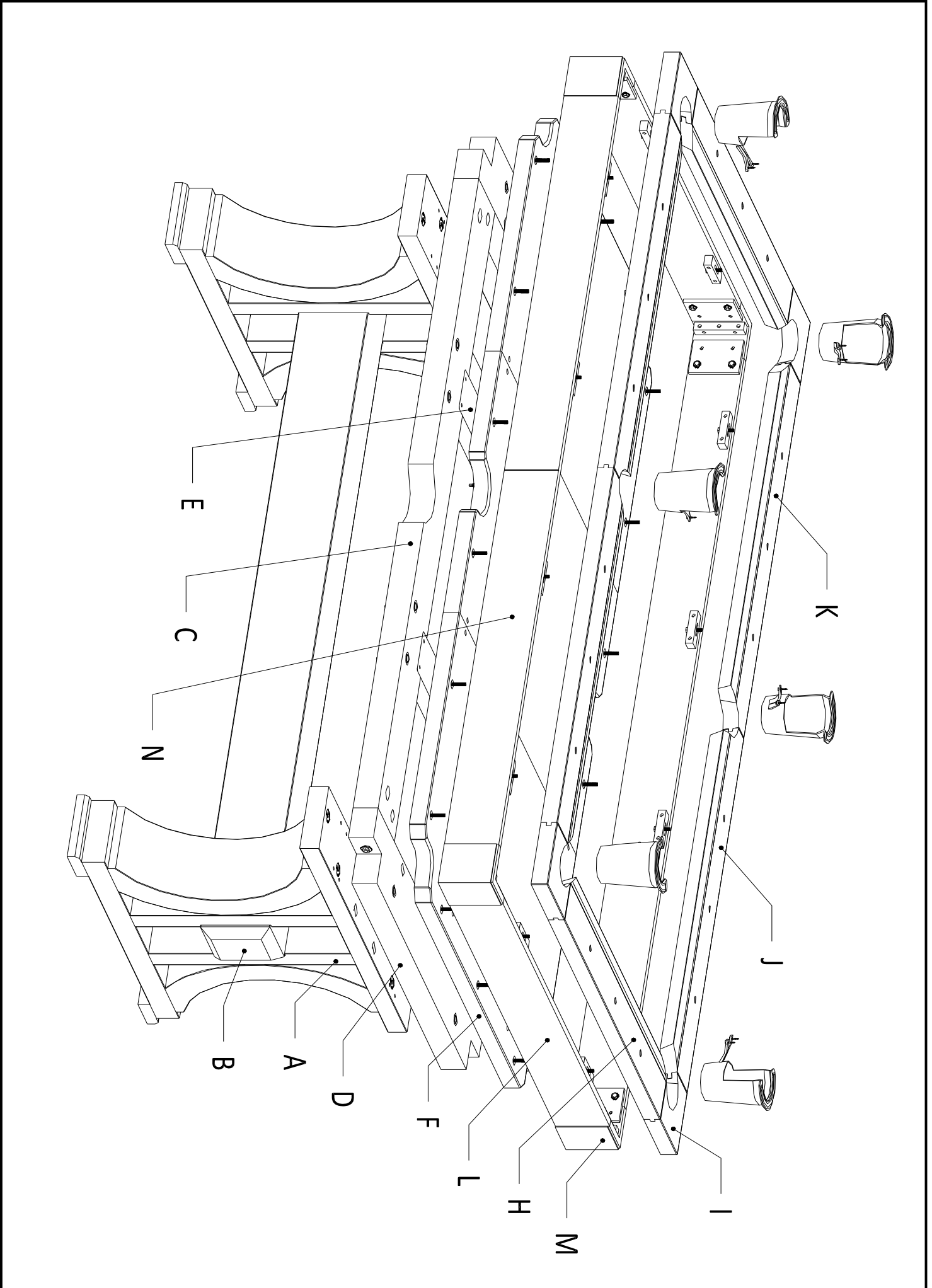

## Steps 1

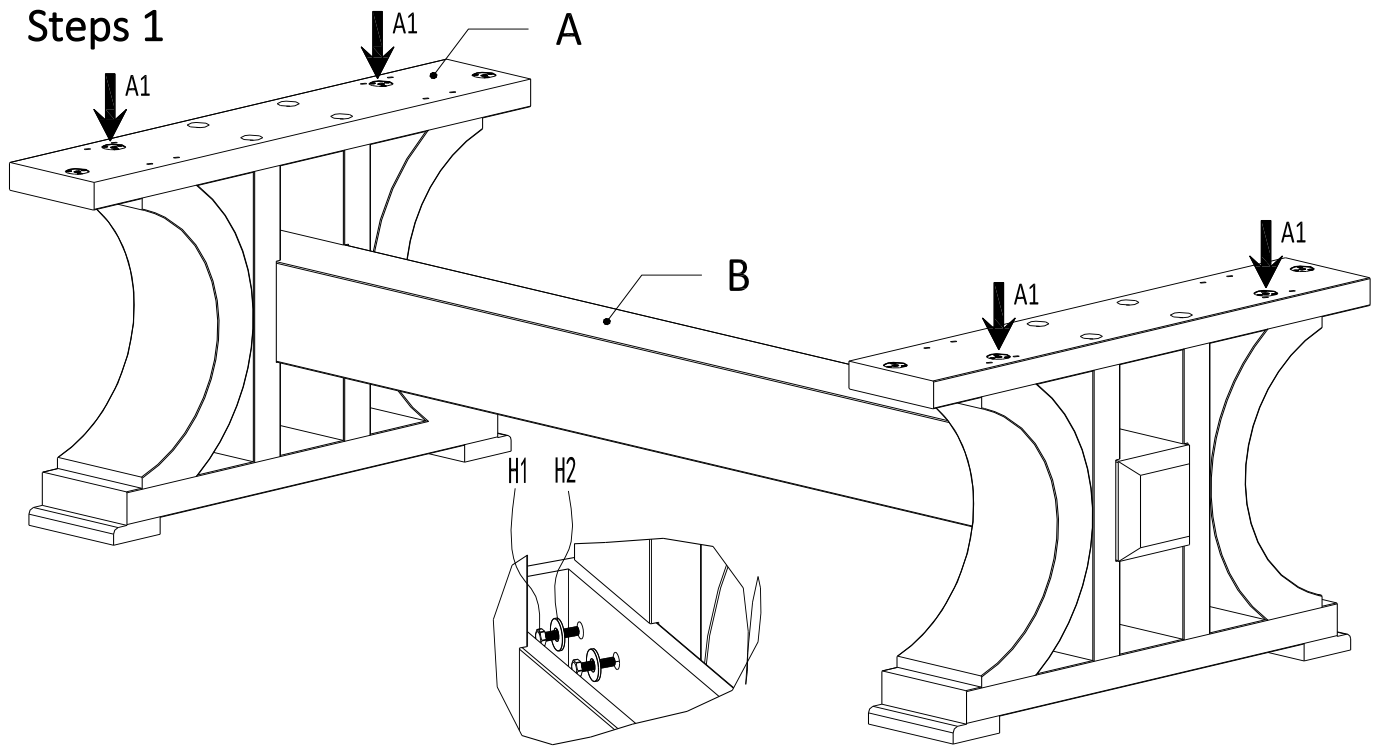

Fasten the table legs (A) and leg panel (B) with hex bolt (H1) and flat washer (H2) .

Note: At least two people are required to install the components. Each leg has two holes (A1) at the top. During the installation process, these two holes (A1) should be oriented outward as shown in the above diagram.

## Steps 2

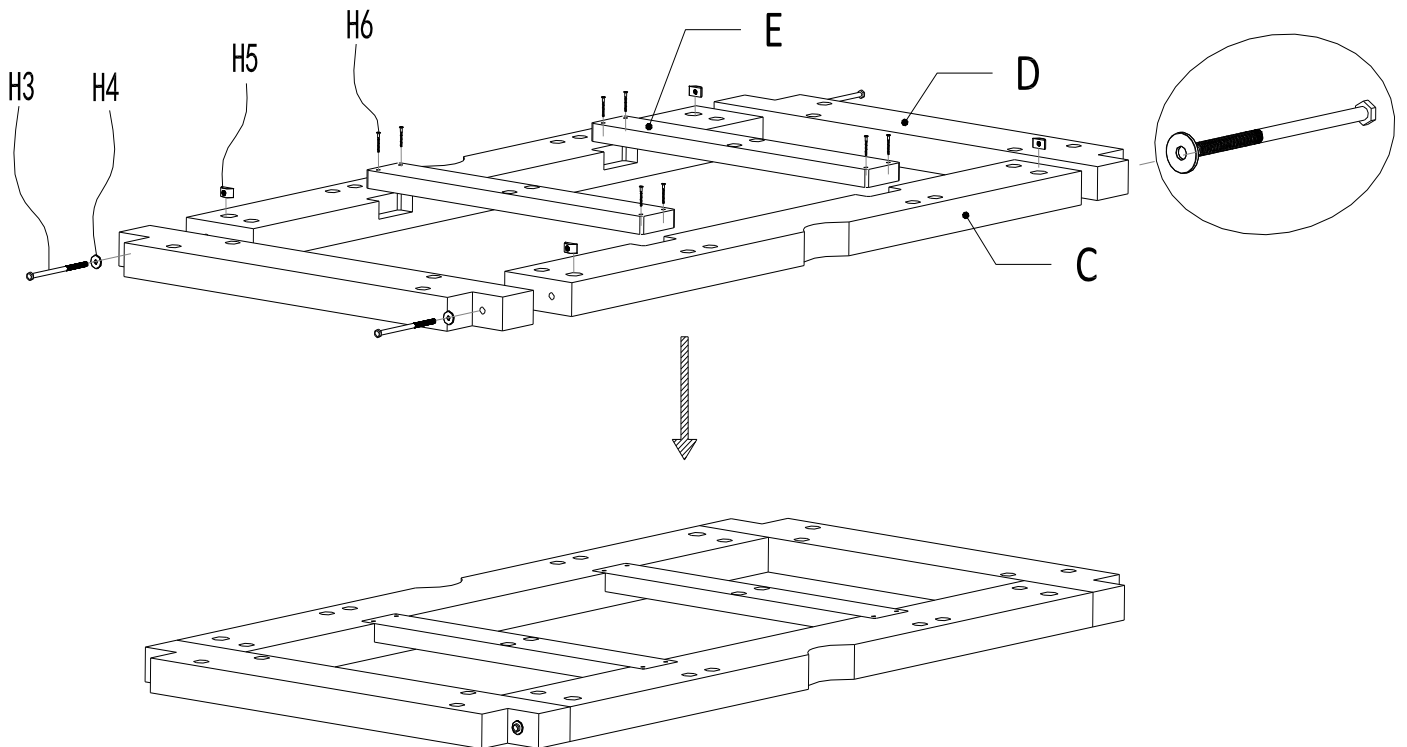

First, connect the Long Beams (C) and the Support Beams (D) using hex bolts (H3), flat washers (H4), and semicircle screw nuts (H5), as shown in the diagram. Don't tighten these bolts all the way yet.

Next, place the Middle Beams (E) into its designated position within the Long Beams (C) as shown. After this, adjust the heights of the long (C) and support beams (D) to ensure they are level or all the cross beams can't be higher than long beams (C). Once they're level, tighten the hex bolts (H3) all the way.

Lastly, use the flat head screws (H6) to firmly attach the Middle Beams (E) to the long beams (C).

### Steps 3

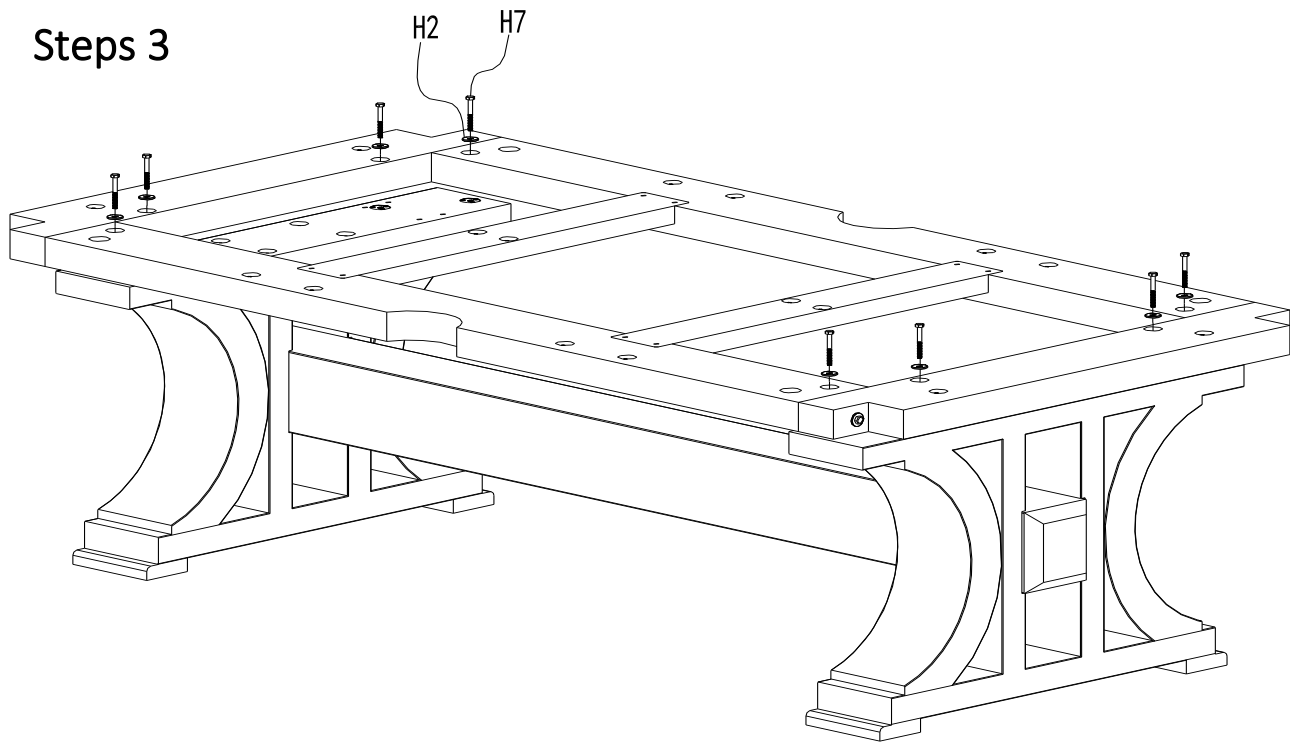

Take the beam component you assembled in (Step 2) and place it on the legs, like in the picture. Use hex head bolt (H7) and flat washer (H2) to attach it securely.

Remember: This part is heavy, so make sure you have at least two people to help. *If you notice a slight misalignment between the mounting holes on the table legs and those on the support beams, you may need to rotate the legs 180 degrees. While the legs appear identical on both sides, the hole positions at the top are different. Incorrect leg orientation can result in misalignment with the length of Part B (Leg Panel) and the pre-drilled holes on Part C & D (Support Beams).*

### Steps 4

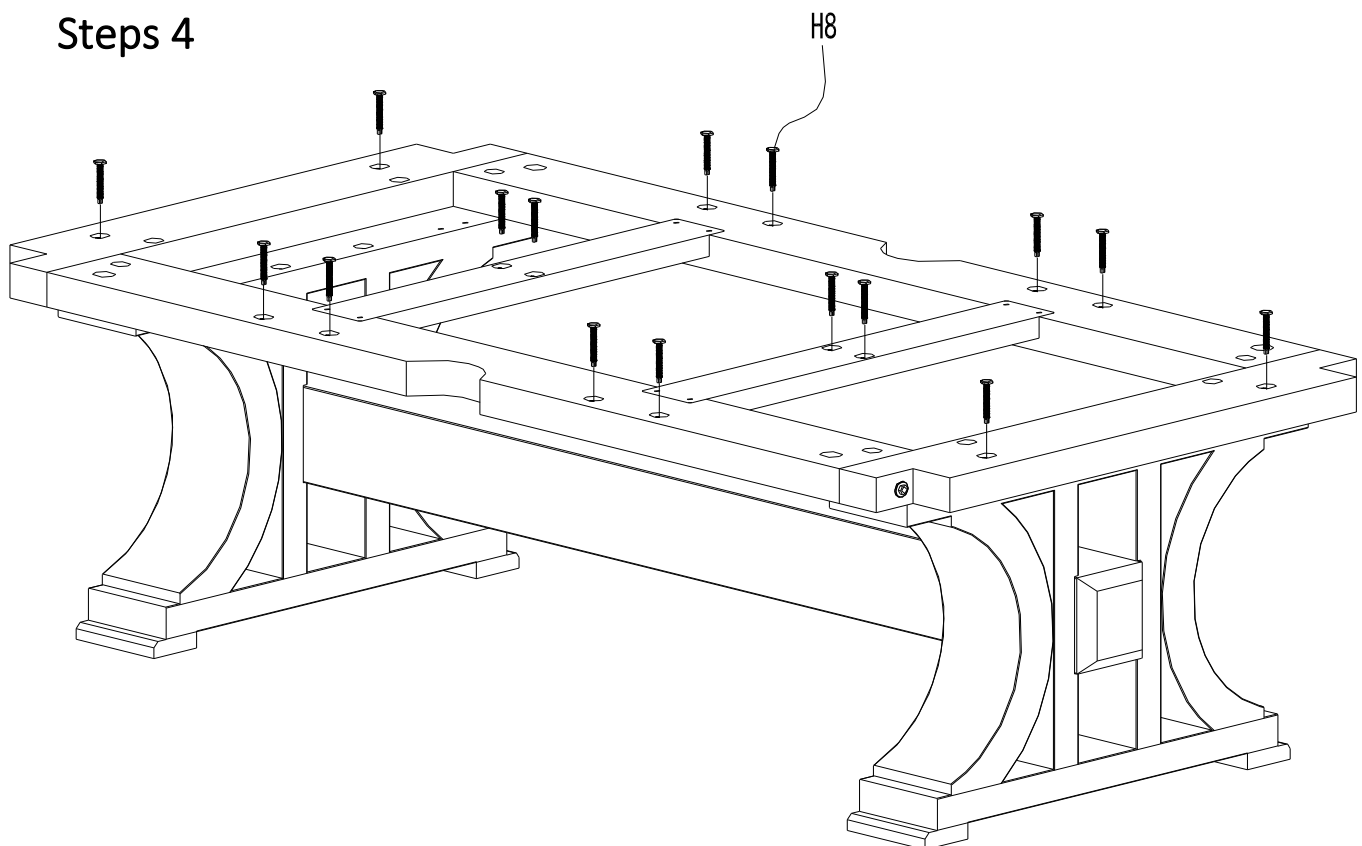

Screw the slate leveler (H8) into the corresponding nut as shown, make sure the top of the slate leveler is a bit lower than the surface of the beam.

## Steps 5

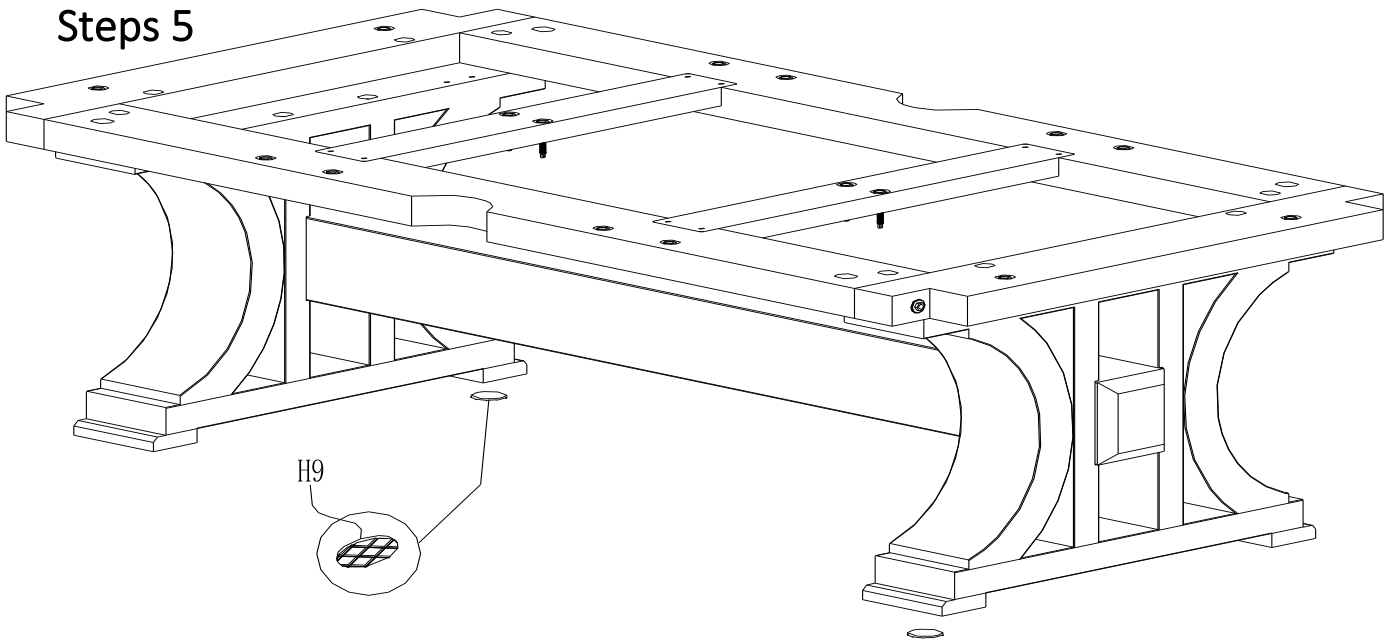

Note: If the floor isn't even, the table might be unstable after you set it up. If that happens, you can use the rubber shims (H9), which are either 2mm or 3mm thick, under the table legs. Adjust these pad total thickness until the frame of the table is almost level. Be sure to use a spirit level(not included with the product) to check if the top of the frame is level. You only need these rubber pads if the floor is uneven. If the floor is level, you don't need them.

## Steps 6

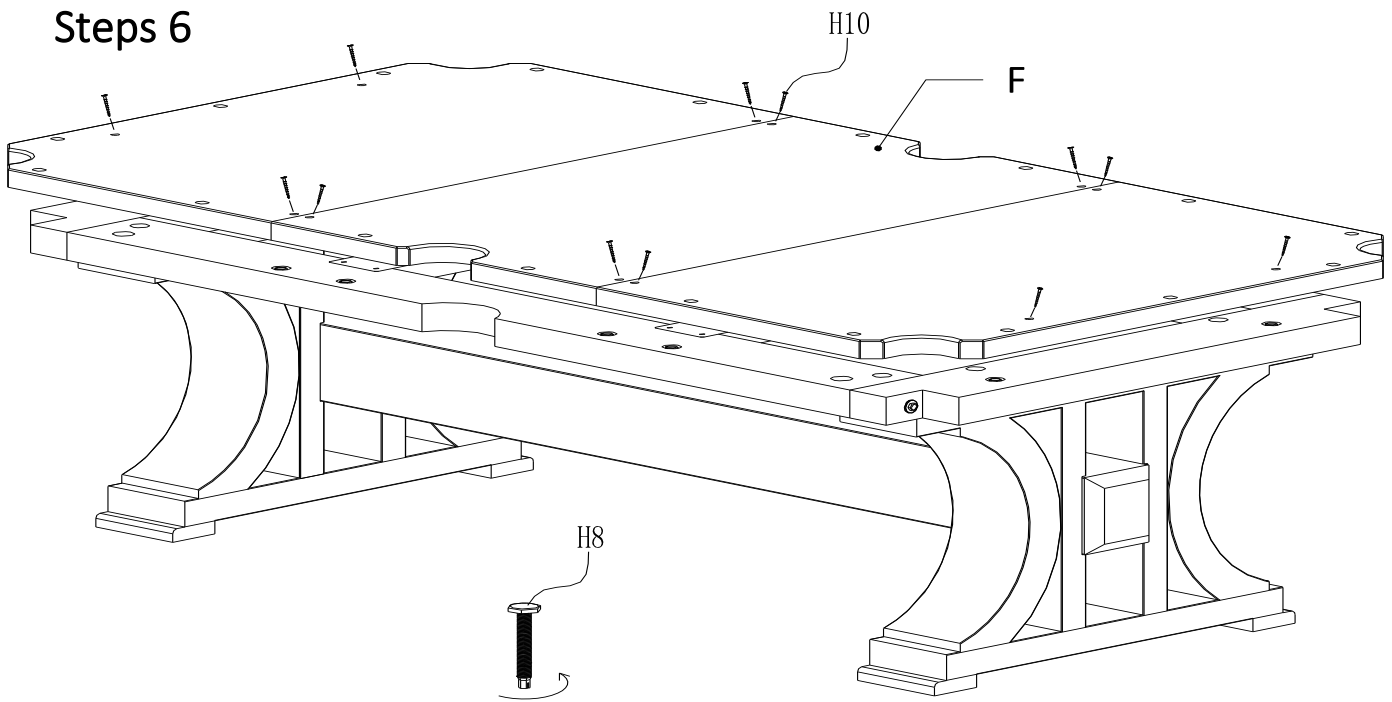

1.Leveling a pool table slate is a specialized task that requires the expertise of a professional pool table installer. If you desire professional-level horizontal flatness for your pool table, it is strongly recommended to seek the services of a qualified pool table installer,if you do want to DIY, you can learn more about "how to level a pool table slate" by watching the video at this link: <https://youtu.be/V-GfbSnjGtg?si=ykYpvu3N6UWGZZvr>, please use the slate levelers (H8) in stead of wooden shim in the video.

2.Place the slate on top of the table frame and center it within the table frame. Ensure that the distance between the edges of the slate and the long frame is consistent, and the same goes for the short frame.

3.Use the slate levelers (H8) to adjust all three pieces of slate to the same level. Then, lock them in place with wooden screws (H10).

Note: Please use a high-precision level to measure the horizontal alignment of the three slate pieces; (the level is not included here). Once you've leveled the slate, make sure that the top of the slate leveler touches the slate. This will help prevent the slate from sinking over time.

## Steps 7

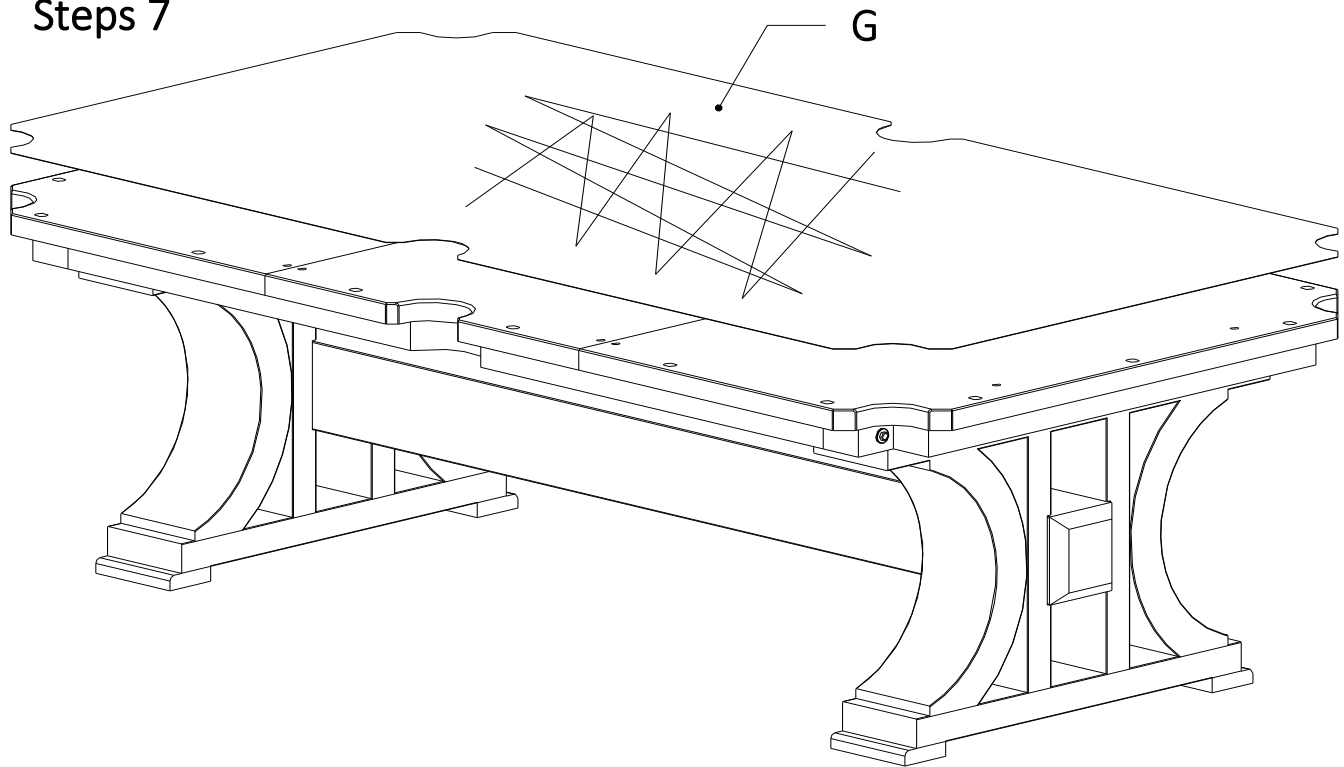

1. Clean the debris on the slate surface, and fill with Beeswax(not included with the product), (you can learn more about this process by watching the video at this link: <https://www.youtube.com/watch?v=wZmM9sJeCXc> ) and sanding until the slate surface is smooth or without any gap between the piece of slate.

2. Clothing a pool table is a highly specialized task, especially when it comes to upholstering the cushion rails. This process requires the expertise of a professional pool table installer. If you're attempting this for the first time, it is strongly advised not to do so and instead, seek the services of a qualified pool table installer. If you want to try it yourself, watch these three videos first:

<https://youtu.be/wy4MksJYGOk?si=9quWW3zwwqPMBPe6>

<https://youtu.be/HM480HPvNjs?si=bqp3G8qaA0TeIkzW>

[www.youtube.com/watch?v=iKS2FIdYS4w](https://www.youtube.com/watch?v=iKS2FIdYS4w) (For 2 long and 2 short rails)

[https://youtu.be/bous6ShN\\_W8?si=DABTiRBRDbrwWTzJ](https://youtu.be/bous6ShN_W8?si=DABTiRBRDbrwWTzJ) (for 6 separate short rails)

3. Next, lay the cloth over the slate. Make sure it's even on all sides. Start by nailing one long side, then pull the opposite side tight and staple it under the slate. Secure it well.

4. Do the same for the short sides. Then trim any extra cloth.

Note: If you're using water-resistant felt from a roll, be careful not to wrinkle it, as this could damage the water-resistant coating.

## Steps 8

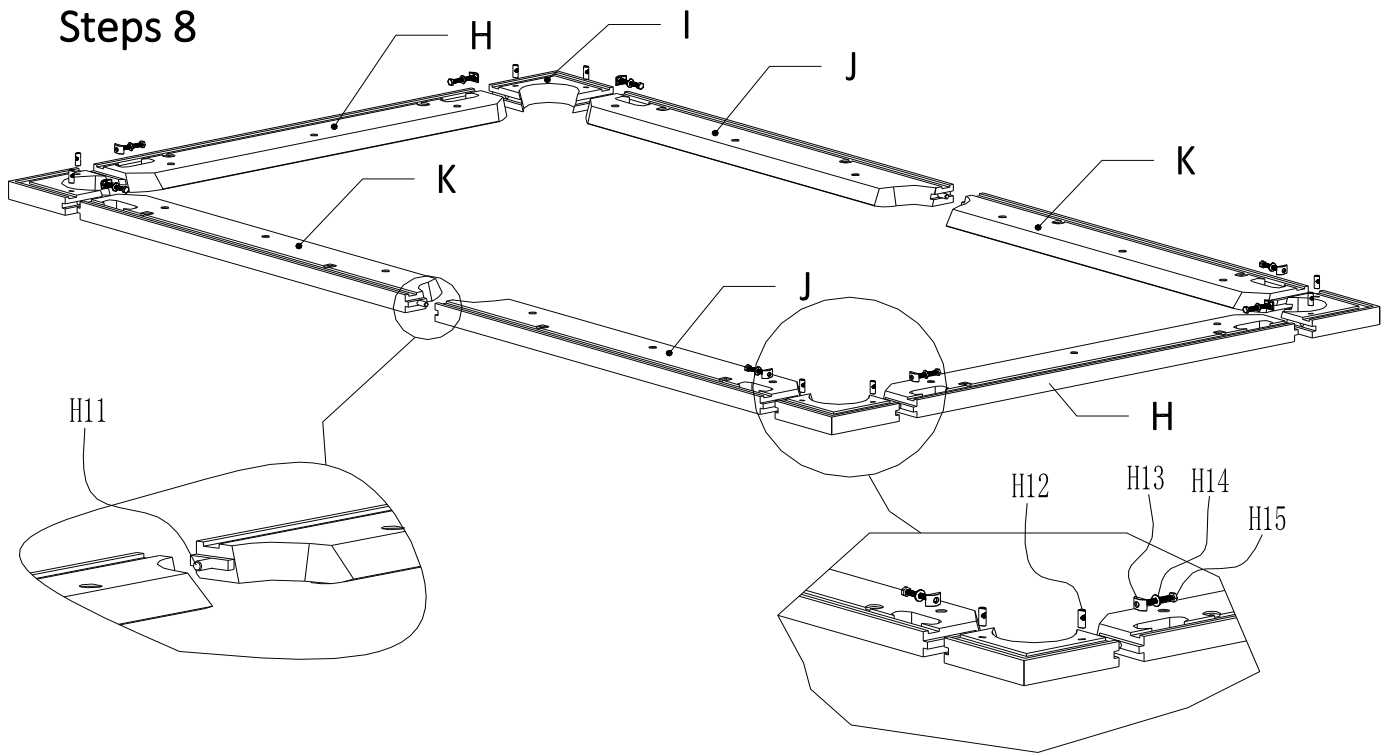

Start by placing the table rails (H, J, K) and rail corners (I) on a flat, protected surface to avoid damage from sharp objects. Note: While the wood grain is natural, you can adjust their positions for a better overall look.

Next, connect the rails (J, K) using wooden plugs (H11). Then, use hex bolts (H15), flat washers (H14), semicircular washers (H13), and barrel nuts (H12) to join and securely tighten the rail corners (I) to the rails (H, J, K).

When installing, before fully tightening the bolts, there are four key tips to make your pool table more professional:

1. All rail surfaces should be as level as possible. This can be ensured if the assembly is placed on a relatively flat surface.
2. The two connected side rails (J, K) should be aligned as straight as possible.
3. All the rails and corners should be connected to form a standard rectangle as closely as possible.
4. The joints between each rail and corner should be as neat and tight as possible.

## Steps 9

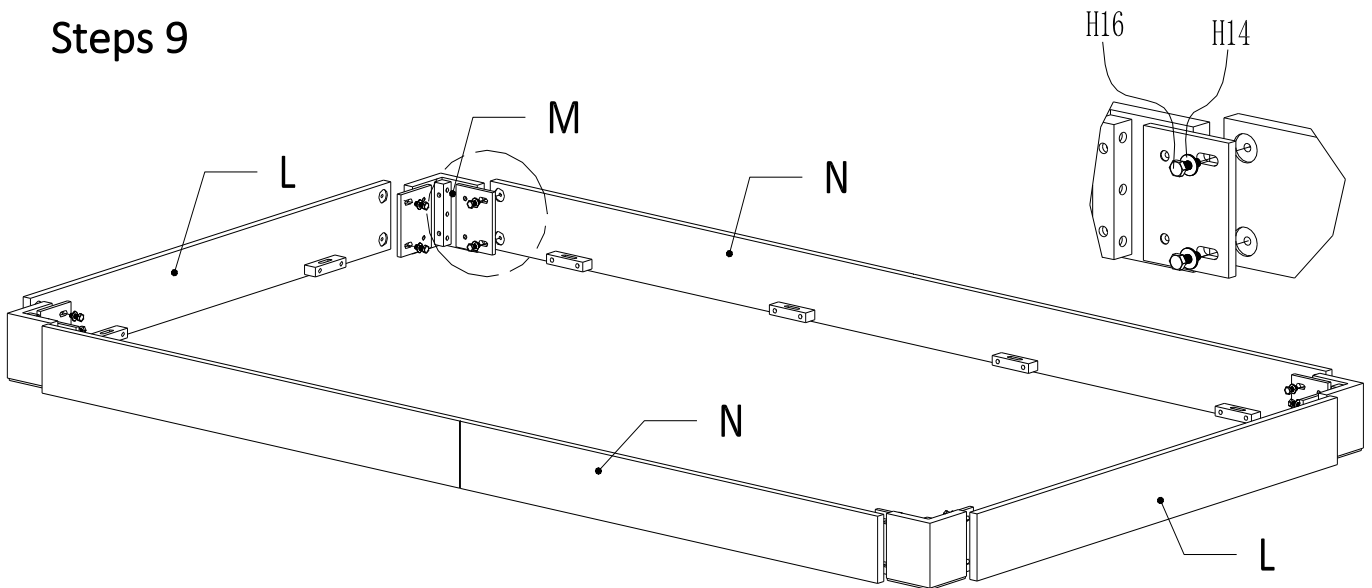

Put the short panels (L), apron corners (M), and long panels (N) on a FLAT surface as indicated in the diagram. Next, join and secure them using hex bolts (H16), washers (H14). Before fully tightening the bolts, ensure that the panel corner is tightly fitted with the panel and they together form a standard rectangle as closely as possible.

Note: While the wood grain is natural, you can adjust their positions for a better overall look.

## Steps 10

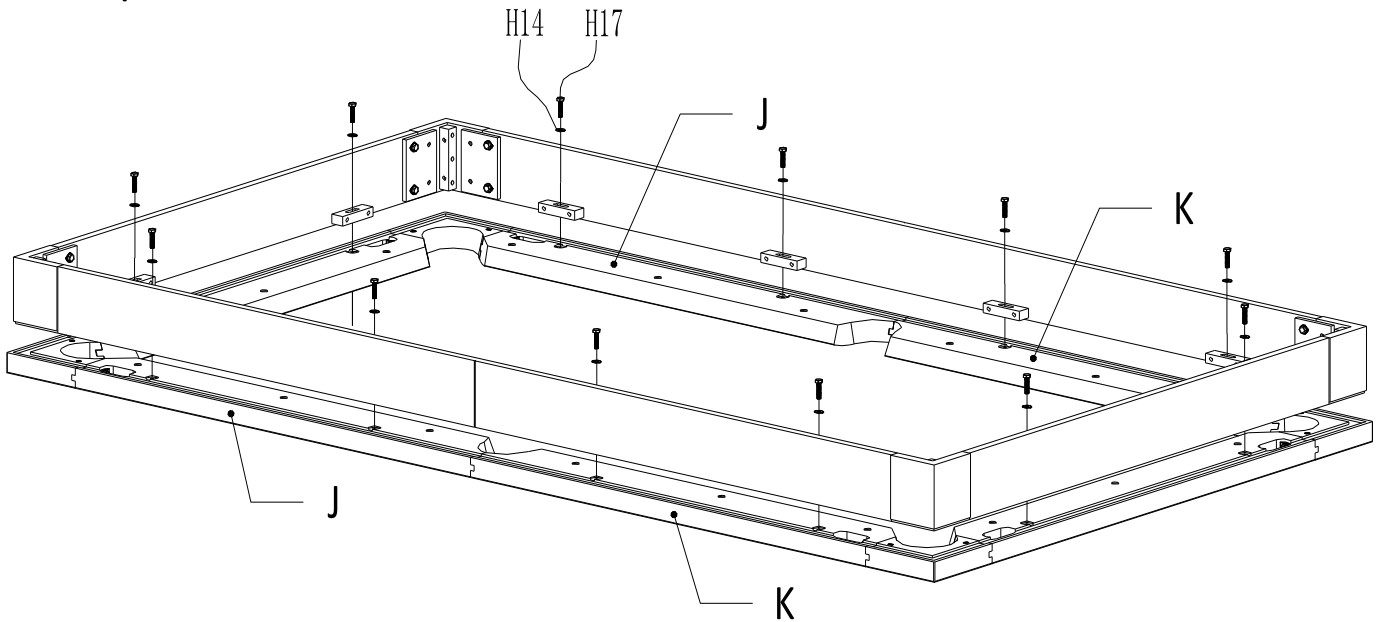

Put the components assembled in (step 9) on top of the components from (step 8) as shown. Adjust the position of the (step 9) components to achieve a tight fit with the components from (step 8). Then, use hex bolts (H17) and flat washers (H14) to join and securely tighten them. Note: This step requires two or more people to complete. When adjusting, start by screwing in the long aprons(N) first, and then attach the short aprons(L) to the rails.

## Steps 11

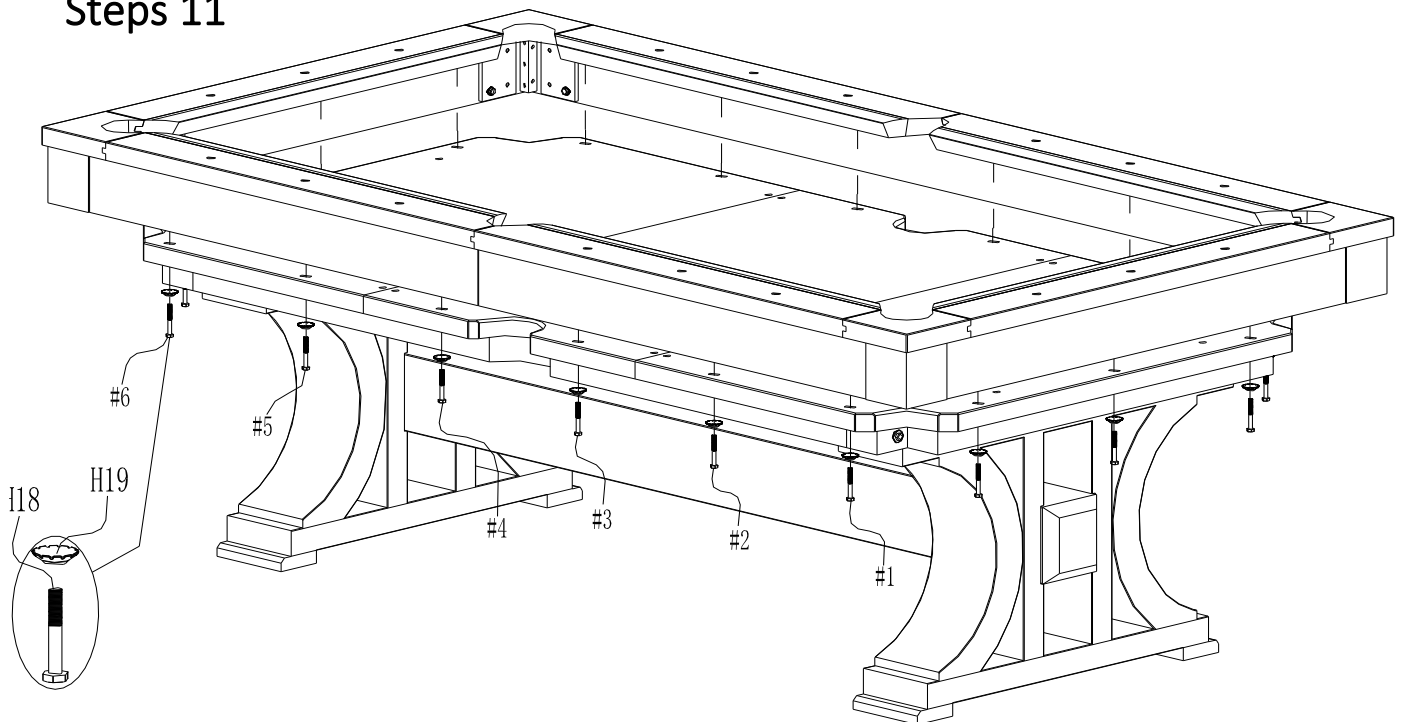

After you complete (step 10), flip it 180 degrees and place it on the slate as shown. Adjust its position to center the assembled table rails components on the slate(F). Then, align the table rails (J, K) in a straight line and use hex bolt (H18) and dome washers (H19) to connect the table rails by passing through the holes in the slate(F).

Caution: 1. The table rail component is heavy, so be careful when flipping it. At least two people are needed for this step.

2. To align the side rail (J,K), first tighten bolts #1 and #6. Then, adjust them by pushing them inwards or outwards at the middle pocket position until its rubber cushion nose lines up straight. Once aligned, fully tighten bolts #3 and #4, and then secure bolts #2 and #5. Repeat the same steps for the opposite side rails (J,K), and finally tighten the two short end rails (H).

## Steps 12

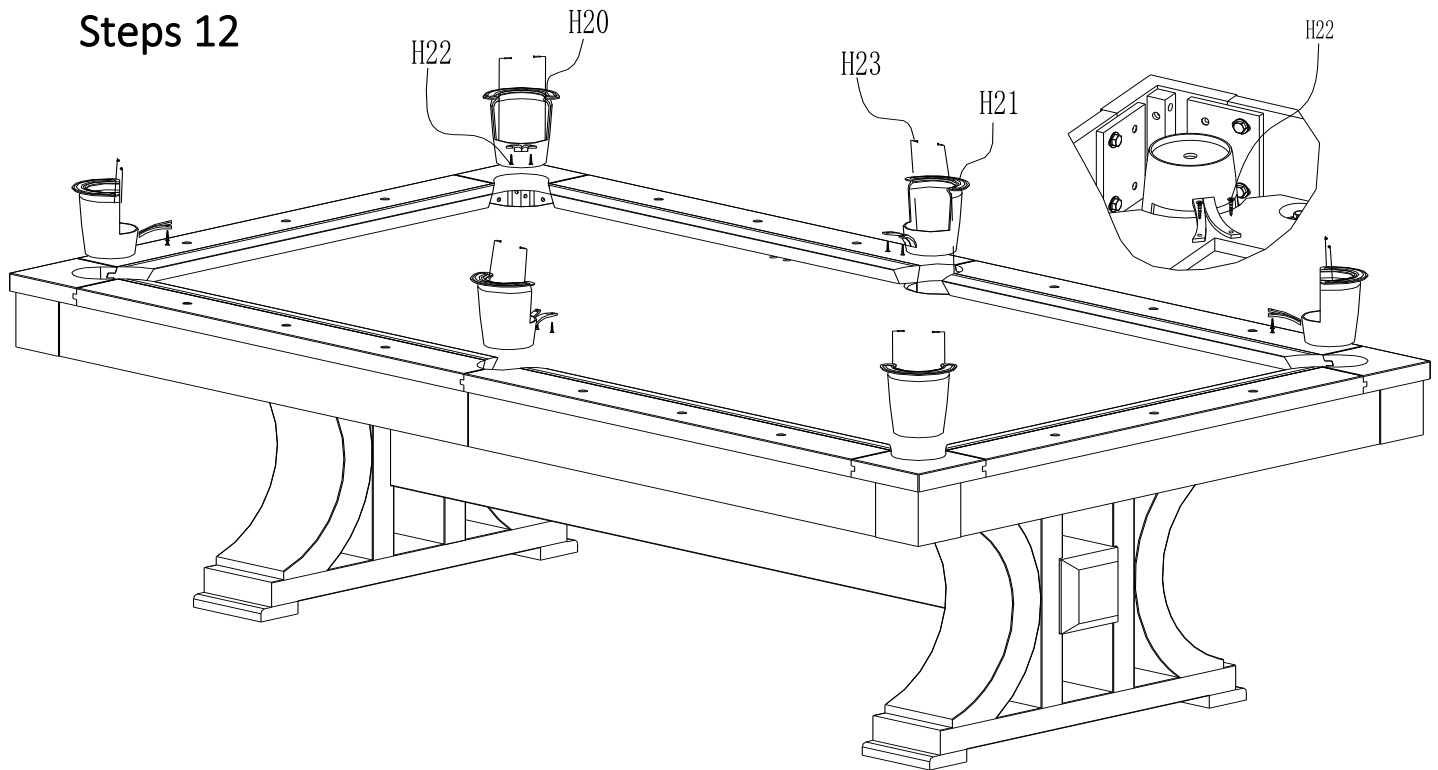

For the side pockets, use side pockets (H21), and for the corner pockets, use corner pockets (H20). Insert them from the bottom of the slate to the top. Be careful not to scratch the top surface of the leather pocket lips. If you want, you can secure the top of the pockets with nails (H23). Then, attach the bottom strips of each pocket with 2 flat head screws (H22).

## Complete

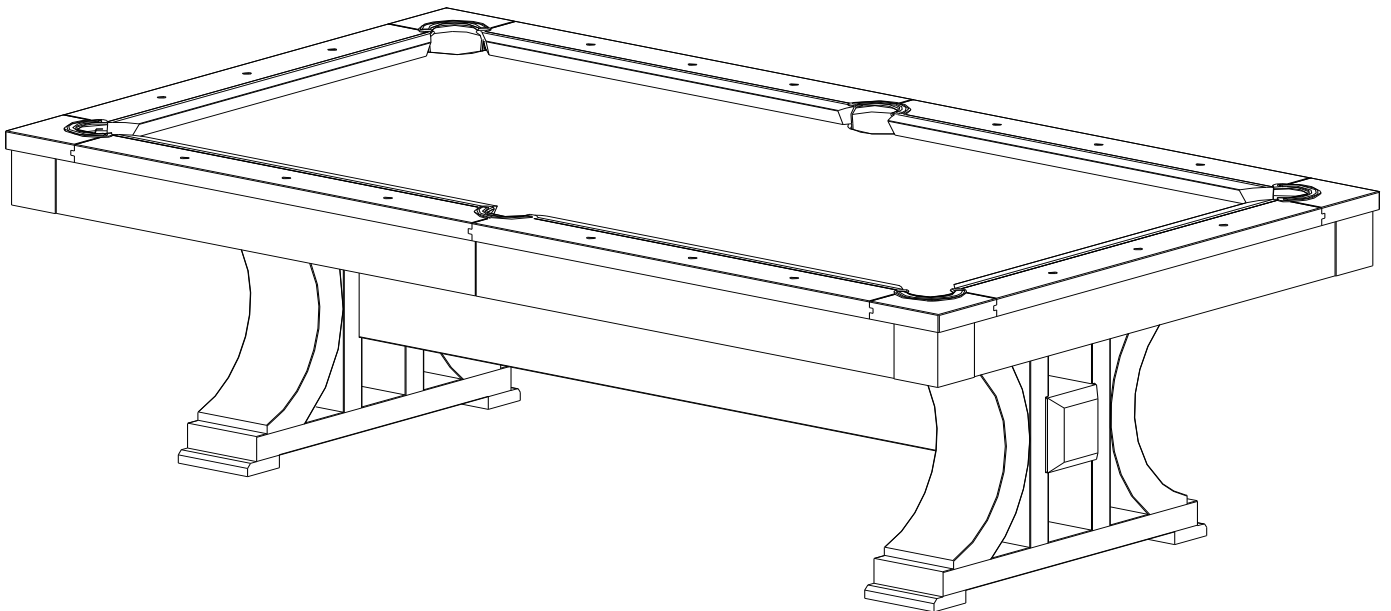

Note: If you want to mark the Head Spot, Foot Spot, and Line on your pool table, you can learn how to do it by watching this video: <https://www.youtube.com/watch?v=GK9rvf09imk>

## Customer Service

If you have any questions about assembly, or if you find parts missing or damaged, please email us at [sales@homeseasoninc.com](mailto:sales@homeseasoninc.com) or text message to 1(909)763-1019

Thank you for choosing Homeseason!