



ASSEMBLY INSTRUCTIONS & PARTS IDENTIFICATION

Thank you for purchasing this quality product. Be sure to check all packing material carefully for small parts that may have come loose inside the carton during shipment.

Hardware kit			
No		Description	Q'Ty
A		Bolt Ø6.3 x 0.794 x 30mm(L)	28 pcs
B		Flat Washer Ø6.3	28 pcs
C		Allen Key	1 pc

**TWO PERSONS ARE REQUIRED
TO SET UP THE TABLE
DO NOT USE POWER TOOLS**

Key Parts			
No	Code	Description	Q'Ty
1		Table Top	1 pc
2		Mounting Plate	1 pc
3		Support Panel Top	1 pc
4		Side Panel with Dowels	1 pc
5		Side Panel - No Dowels	5 pcs
6		Support Panel Bottom	1 pc
7		Hinge	8 pcs
8		Floor Glide	12 pcs

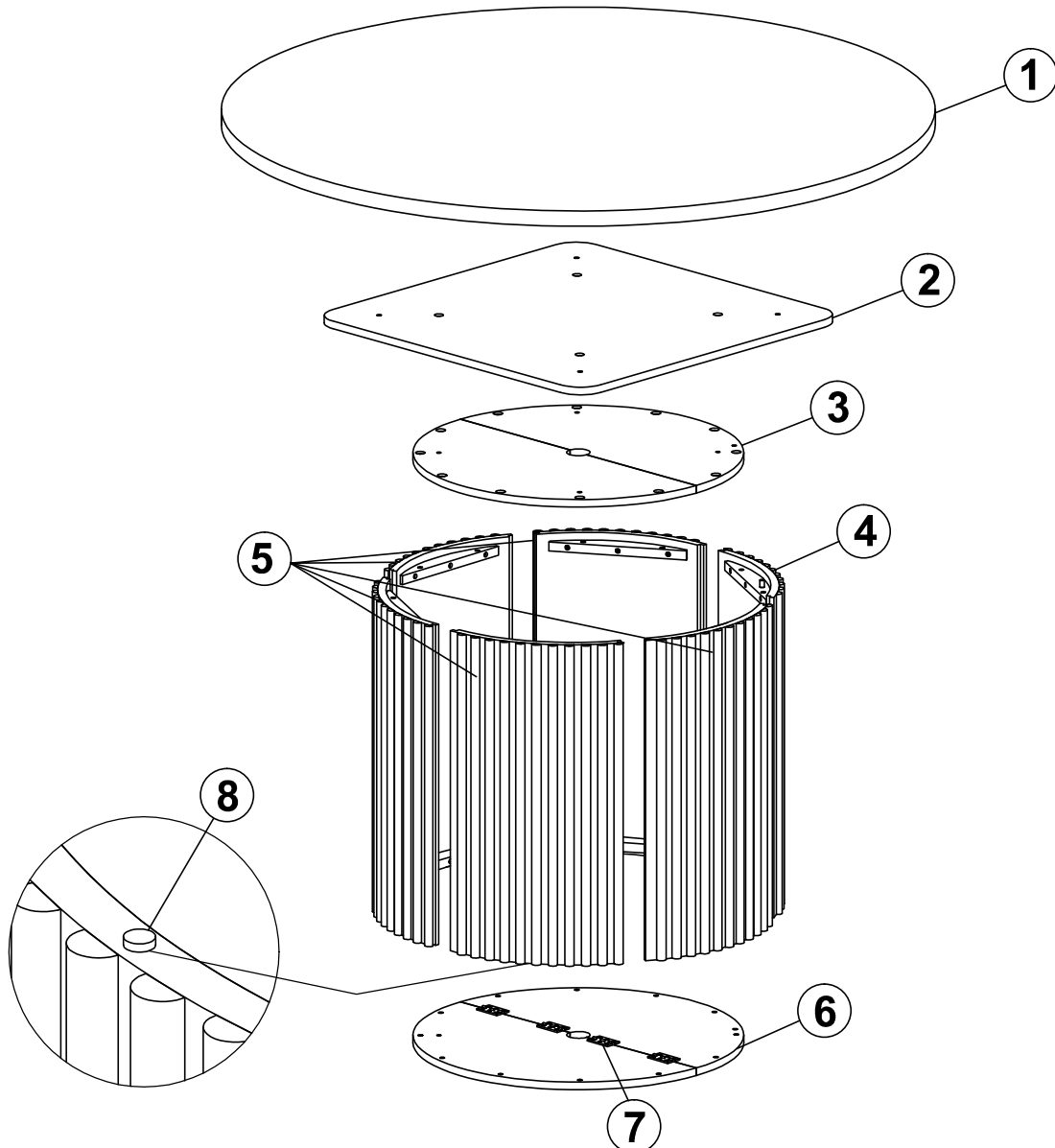

ASSEMBLY INSTRUCTIONS & PARTS IDENTIFICATION

Thank you for purchasing this quality product. Be sure to check all packing material carefully for small parts that may have come loose inside the carton during shipment.

STEP 1

- Carefully lay the Side Panel with Dowels on a smooth flat surface to prevent scratches.
- Attach the Support Panel Bottom and Support Panel Top to the Side Panel with Dowels using a Bolt (A), Flat Washer (B) and Allen Key (C) provided . (See Detail A)

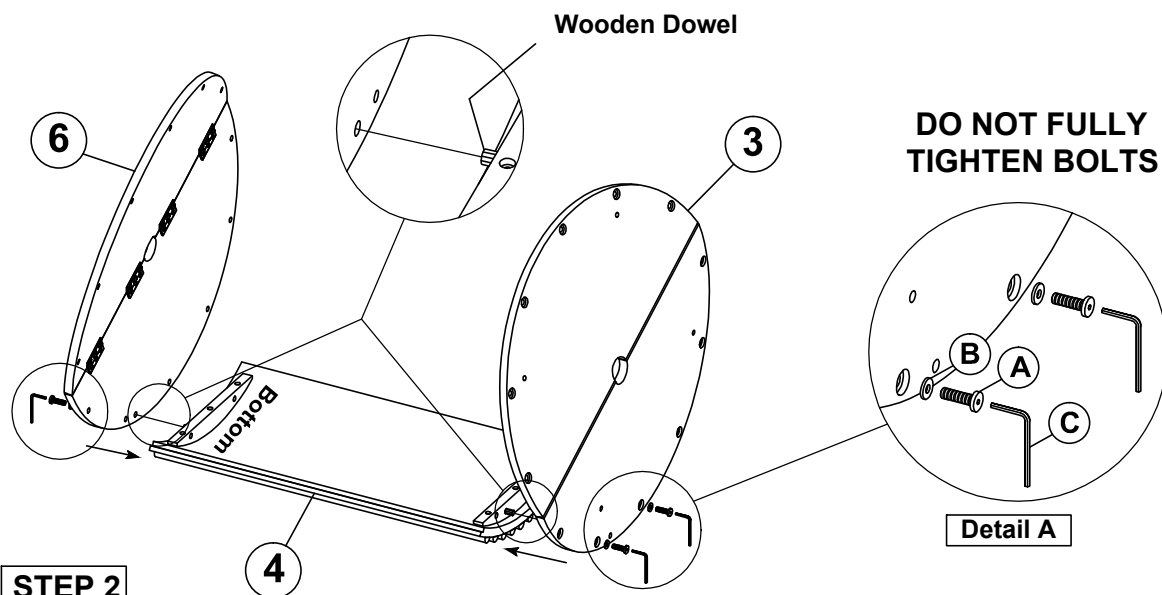

STEP 2

- Attach the Side Panel without the Dowels to the Support Panel Bottom and Support Panel Top using a Bolt (A) Flat Washer (B), and Allen Key (C) provided. (See Detail B)

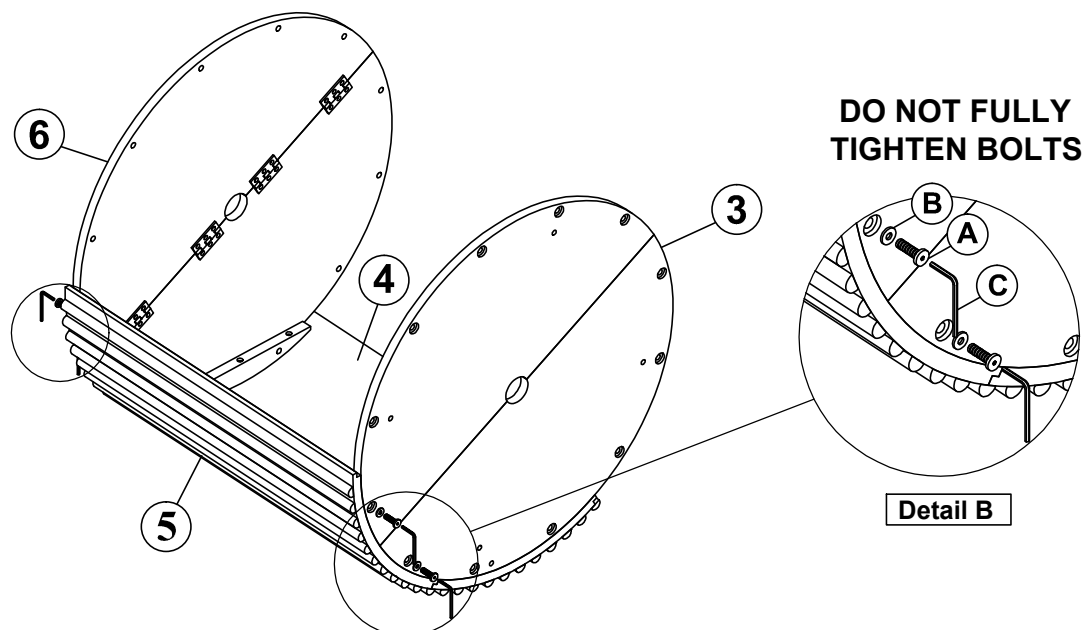

ASSEMBLY INSTRUCTIONS & PARTS IDENTIFICATION

Thank you for purchasing this quality product. Be sure to check all packing material carefully for small parts that may have come loose inside the carton during shipment.

STEP 3

-Continue to attach the Side Panels without the Dowels to the Top and Bottom Support panels until all the Side panels are in place.

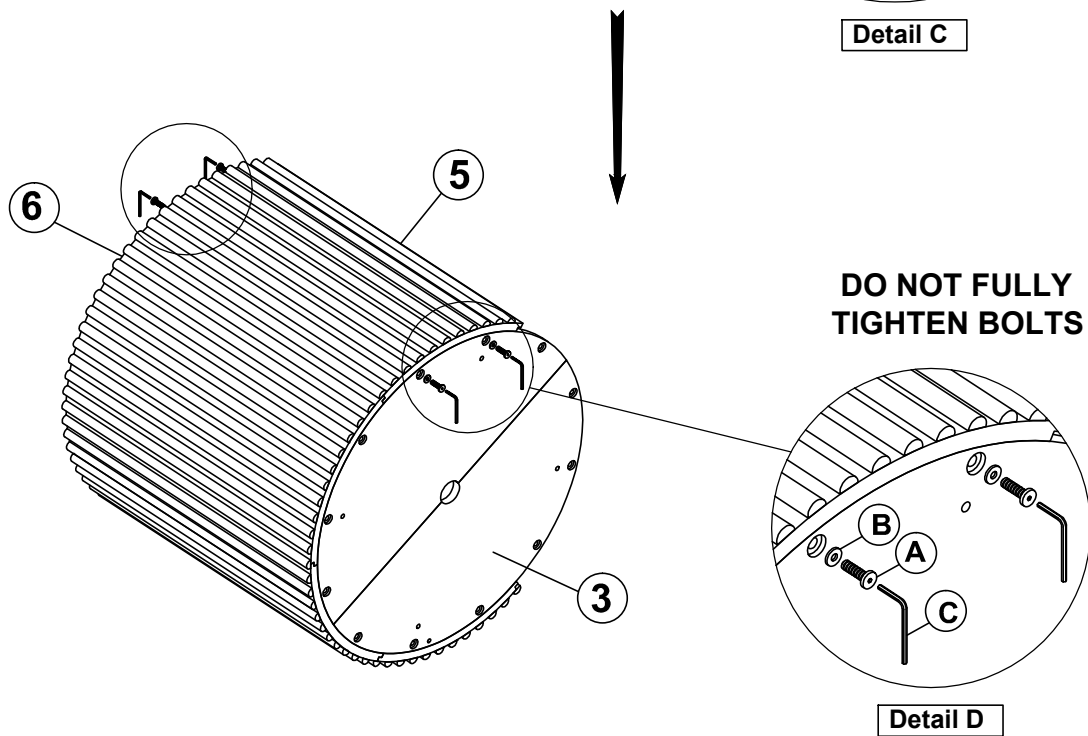
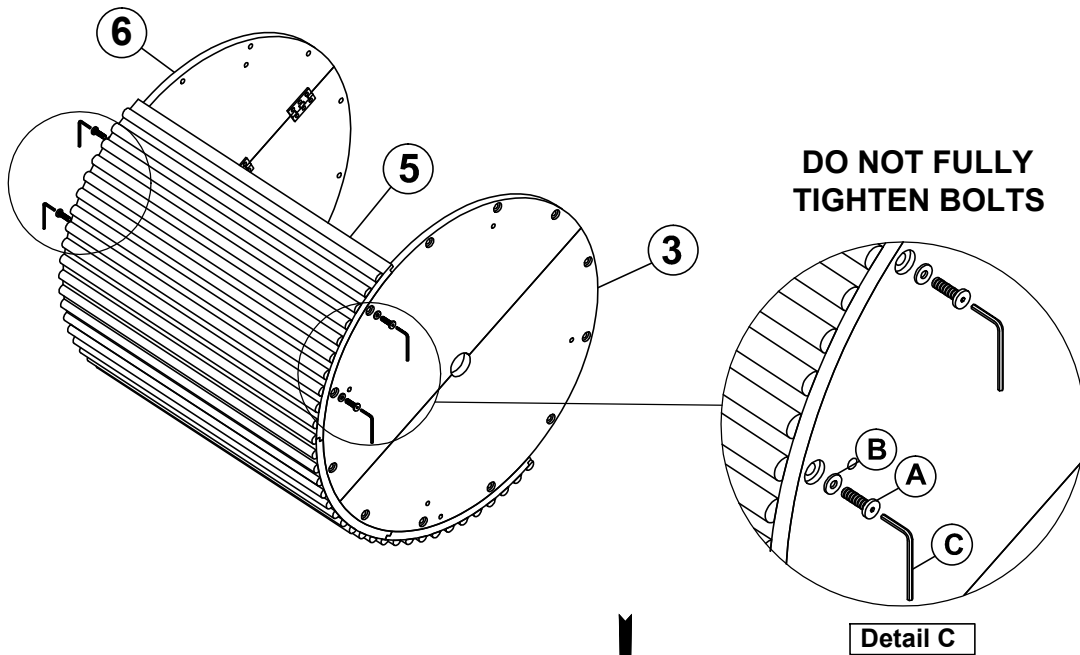

ASSEMBLY INSTRUCTIONS & PARTS IDENTIFICATION

Thank you for purchasing this quality product. Be sure to check all packing material carefully for small parts that may have come loose inside the carton during shipment.

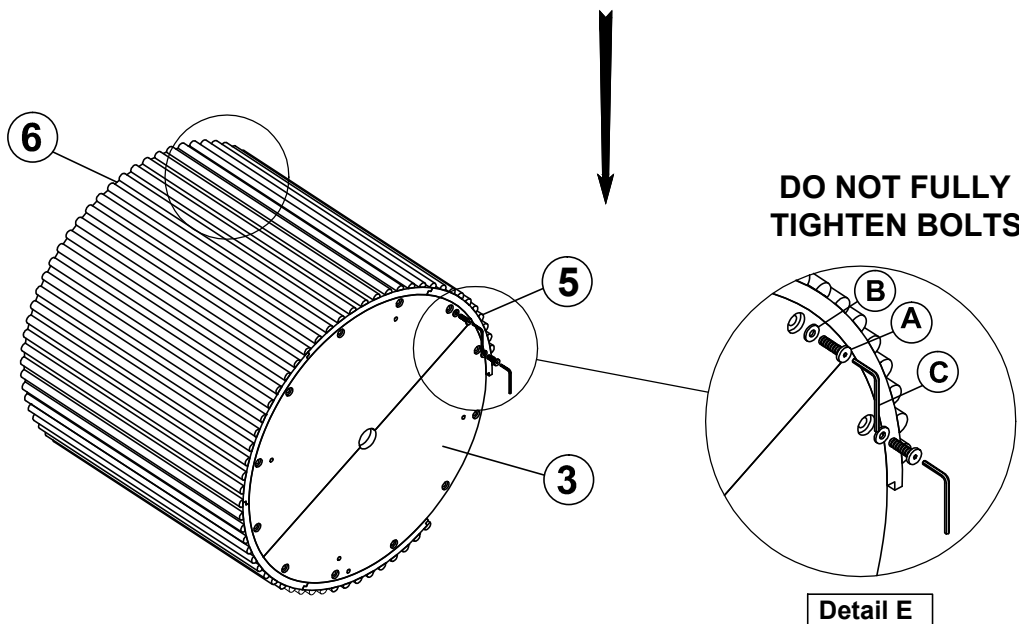

STEP 4

- It may be necessary to slightly shift the Side Panels once you attach the last one.
- Once all the panels are in place, tighten all bolts on the top and bottom.

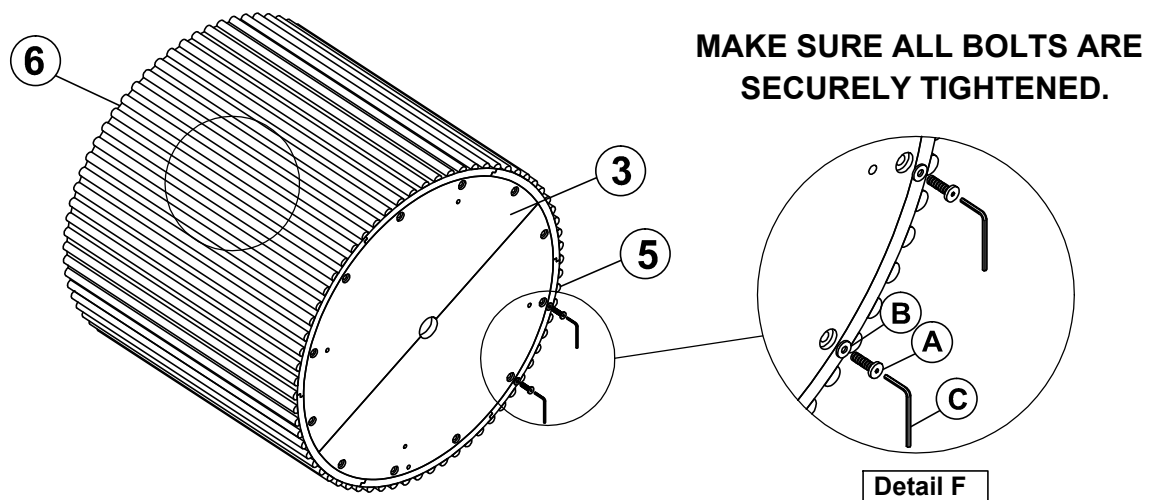

ASSEMBLY INSTRUCTIONS & PARTS IDENTIFICATION

Thank you for purchasing this quality product. Be sure to check all packing material carefully for small parts that may have come loose inside the carton during shipment.

STEP 5

- Carefully lay Table Top on a smooth flat surface to prevent scratches.
- Remove the Mounting Plate from Table Top using Allen Key (C) provided .

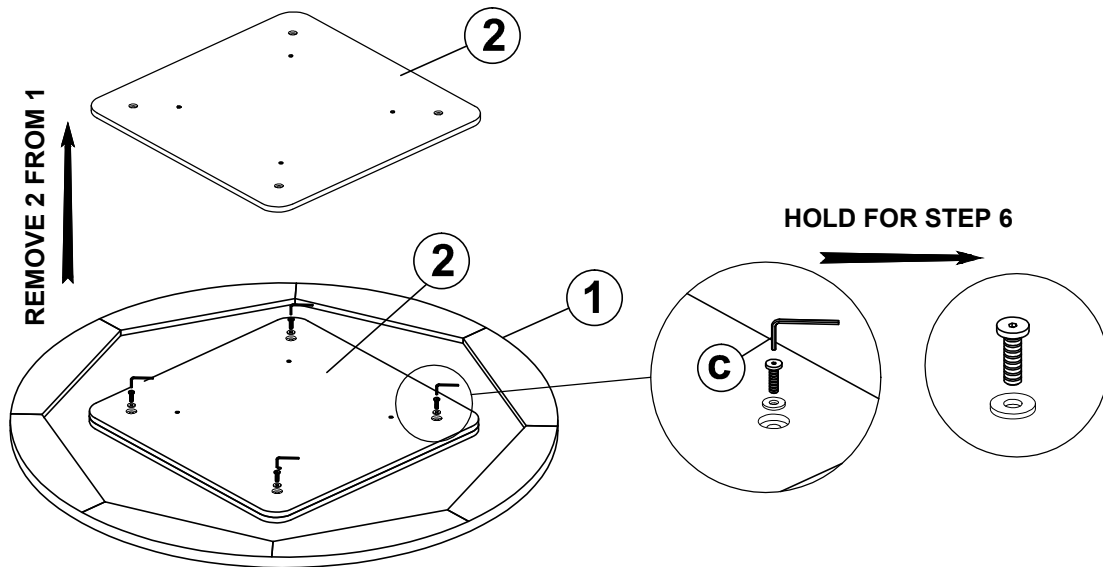

STEP 6

- Attach the Mounting Plate to the top of the assembled Pedestal Base using a Bolt, Flat Washer disconnected in Step 5 and Allen Key (C) provided. (See Detail G)
- Make sure all bolts are securely tightened.

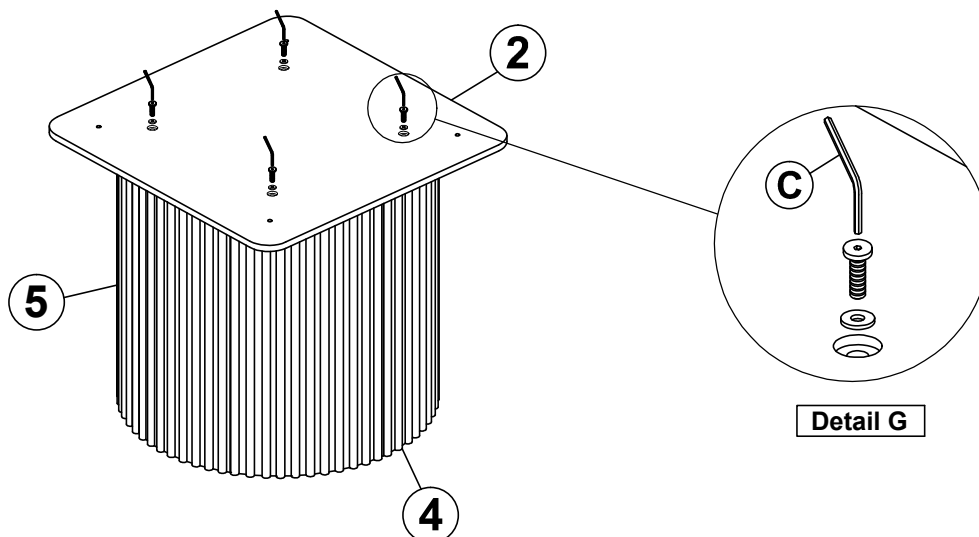

ASSEMBLY INSTRUCTIONS & PARTS IDENTIFICATION

Thank you for purchasing this quality product. Be sure to check all packing material carefully for small parts that may have come loose inside the carton during shipment.

STEP 7

- Lay the Table Top upside down on a clean padded surface to prevent scratching.
- Attach the Mounting Plate to the Table Top using a Bolt (A), Flat Washer (B) and Allen Key (C) provided. (See Detail H)
- Make sure all bolts are securely tightened.
- With help from the second person, carefully turn the table upright.

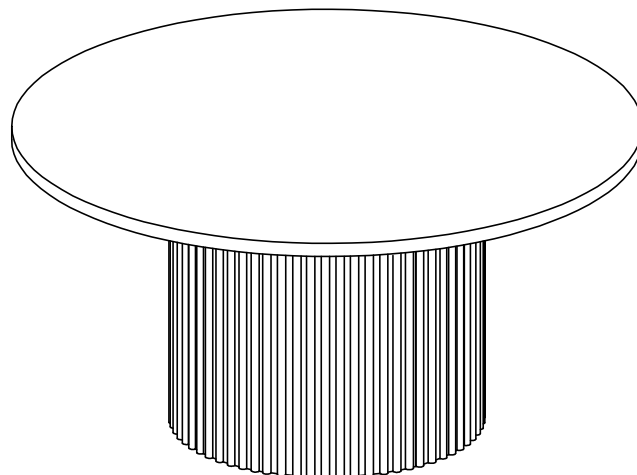
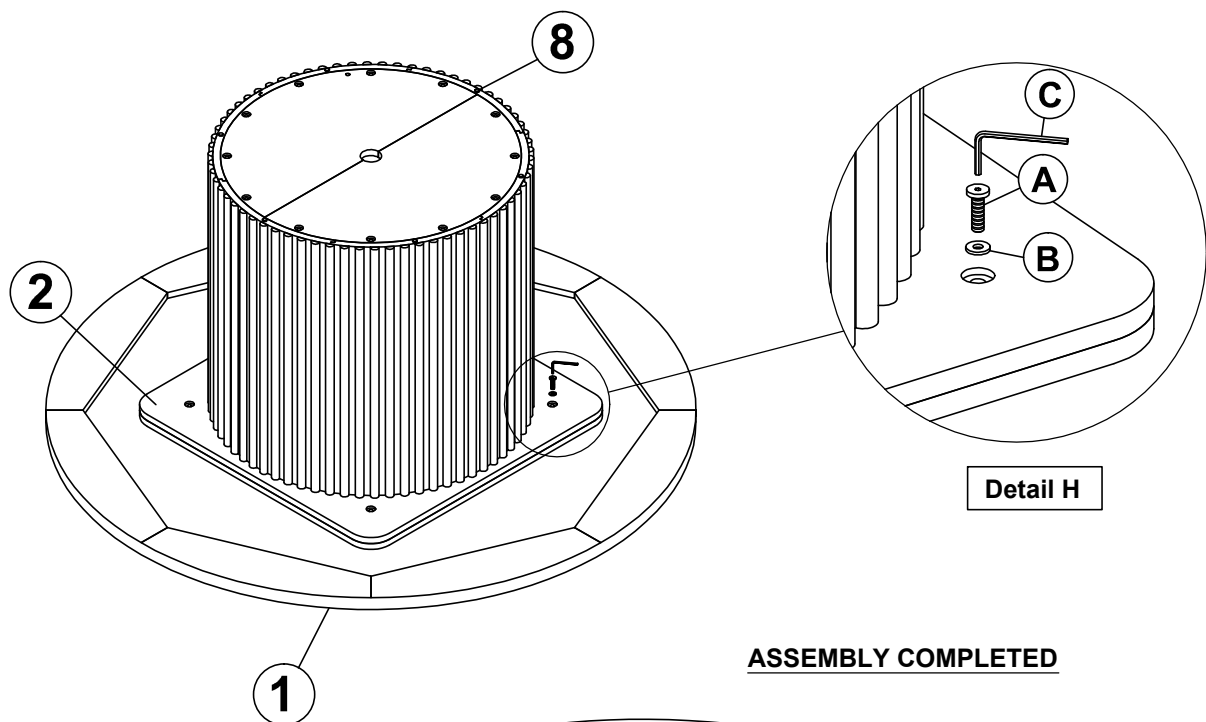

DO NOT ATTEMPT TO TRANSPORT THE TABLE WITH THE BASE ATTACHED.
TOP MUST BE REMOVED AND TRANSPORTED AS TWO PIECES.