

Installation Instruction

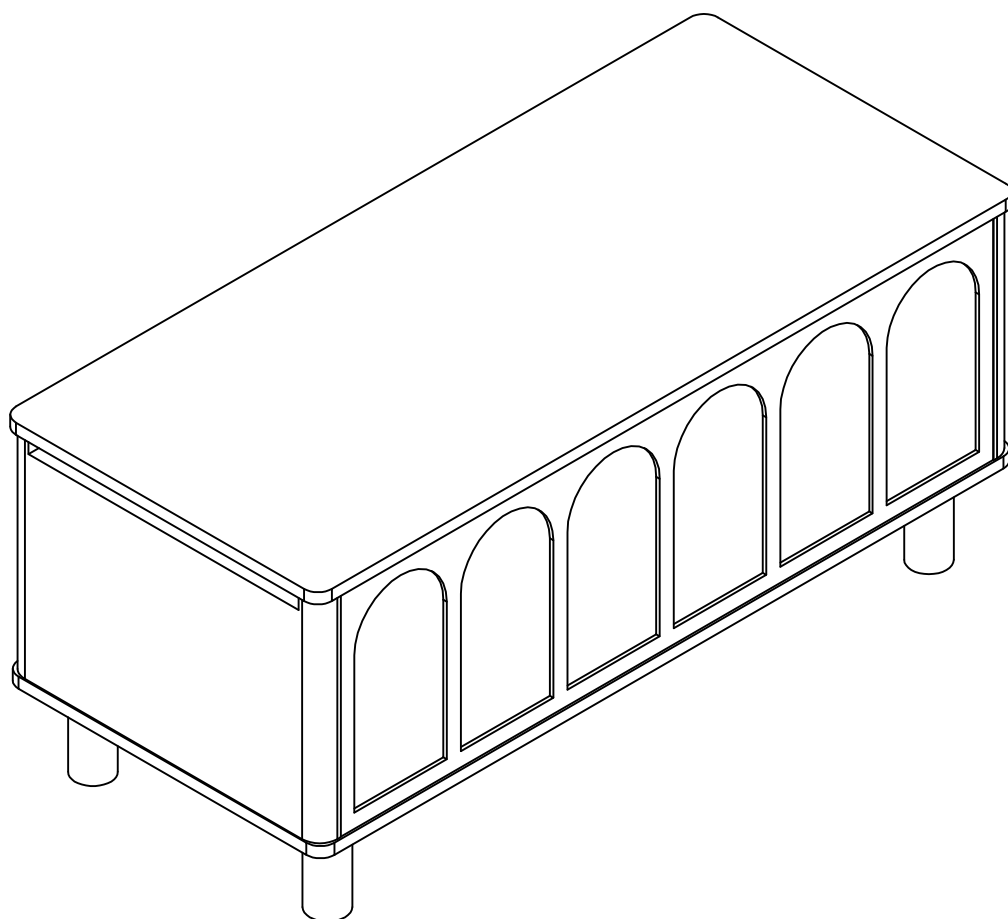

Assembling

What' included

What you need

- Use the packaging carton as a working surface to prevent product damage during assembly
- Phillips head screwdriver

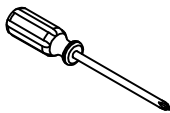

Weight Limitation

 **100** | **35**
lbs table top lbs per

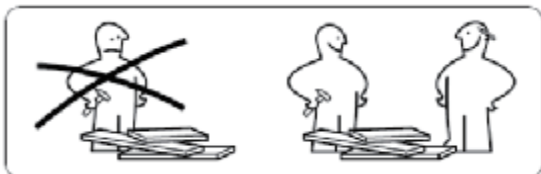

Code	Description	Qty
A	Cam Bolt M6X35MM	8
B	Cam Lock 15X9MM	8
C	Wooden Dowel M6X30MM	12
D	Screw M4X40MM	10
E	Screw M3.5X14MM	16
F	Left regulator	1
G	Right regulator	1
H	Screw M3.5X14MM	20
I	Foot nail	4
J	Wrench M4X55MM	1
K	Phillips screwdriver	1
L	Hole position sticker	8
M	Screw M6X25MM	2
N	Four-hole iron sheet	4

The Hardwares

(A)

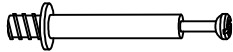

(B)



(C)



(D)

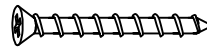

(E)



(F)

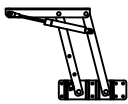

(G)

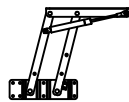

(H)



(I)



(J)



(K)



(L)

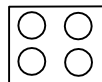

(M)



(N)

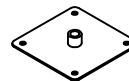

IMPORTANT:

1. Do not tighten bolts / screws completely until all bolts / screws are lined up and inserted into holes.
2. Do not over tighten screws and bolts to avoid stripping
3. Please use hand tools to assemble this product, you can also use power tools (please use power tools carefully)

Included Accessories

Code	Description	Qty
1	Cabinet Top	1
2	Bottom Panel	1
3	Left Side Panel	1
4	Right Side Panel	1
5	Anteroposterior plate	2
6	Connecting pipe	1
7	Supporting foot	4

The Accessoriess

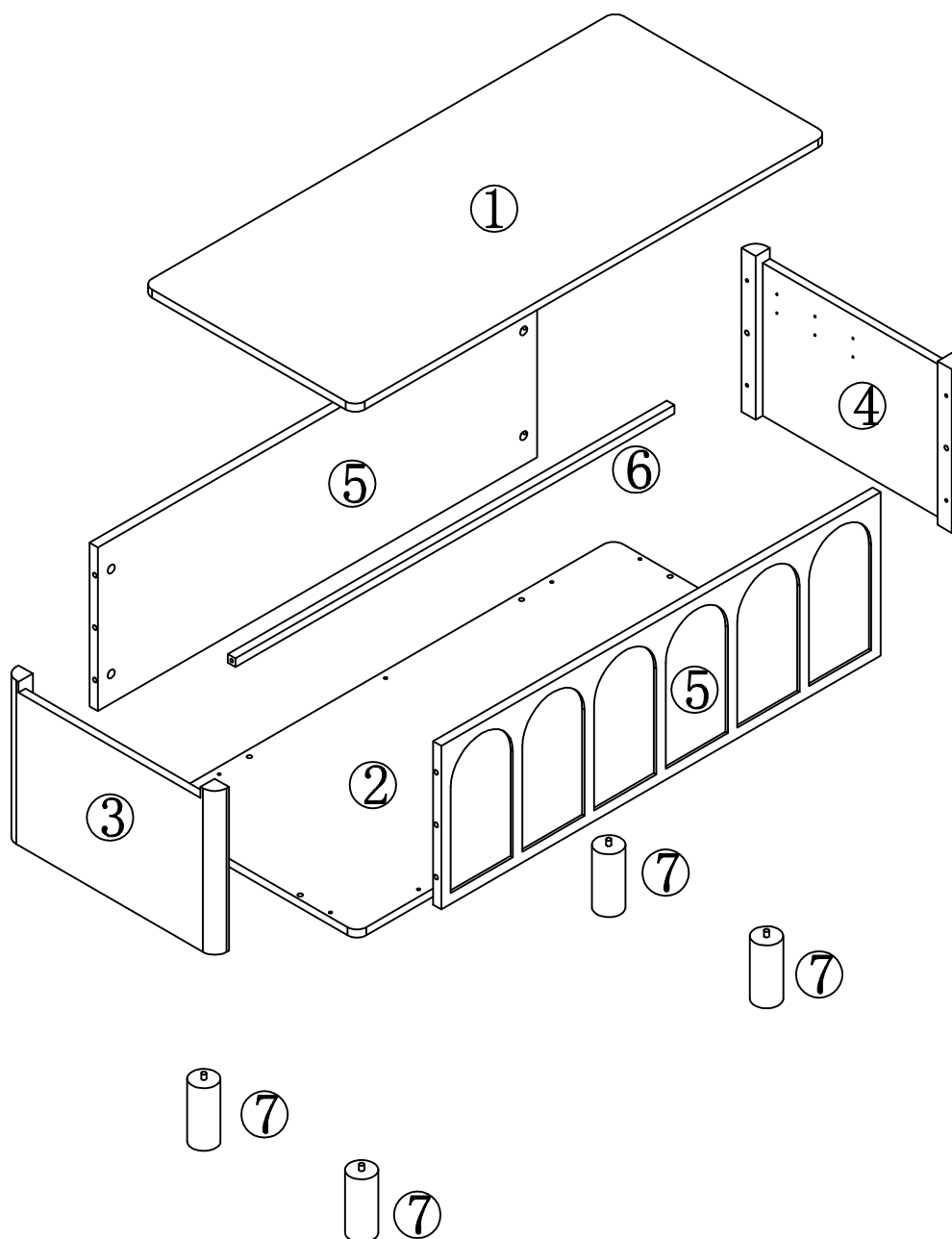

Step 1

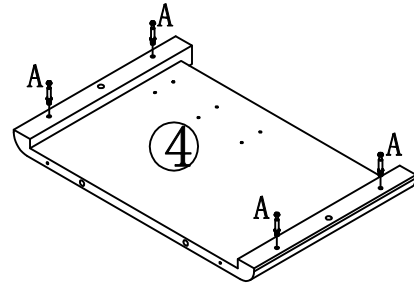
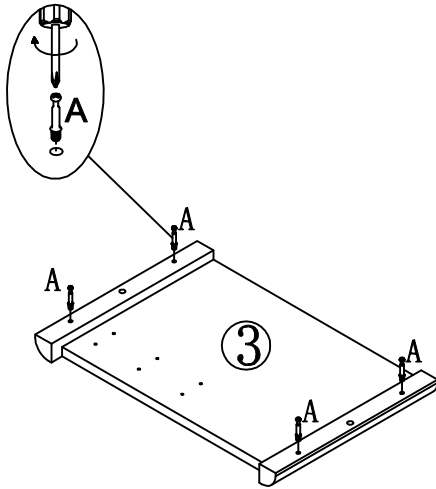
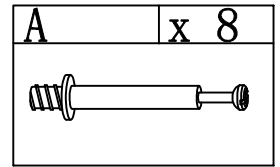

Step 2

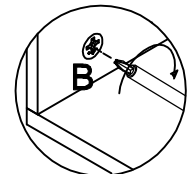
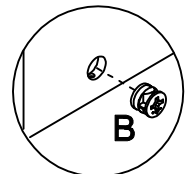
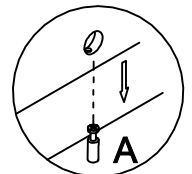
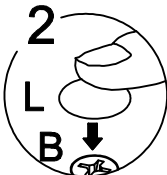
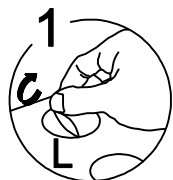
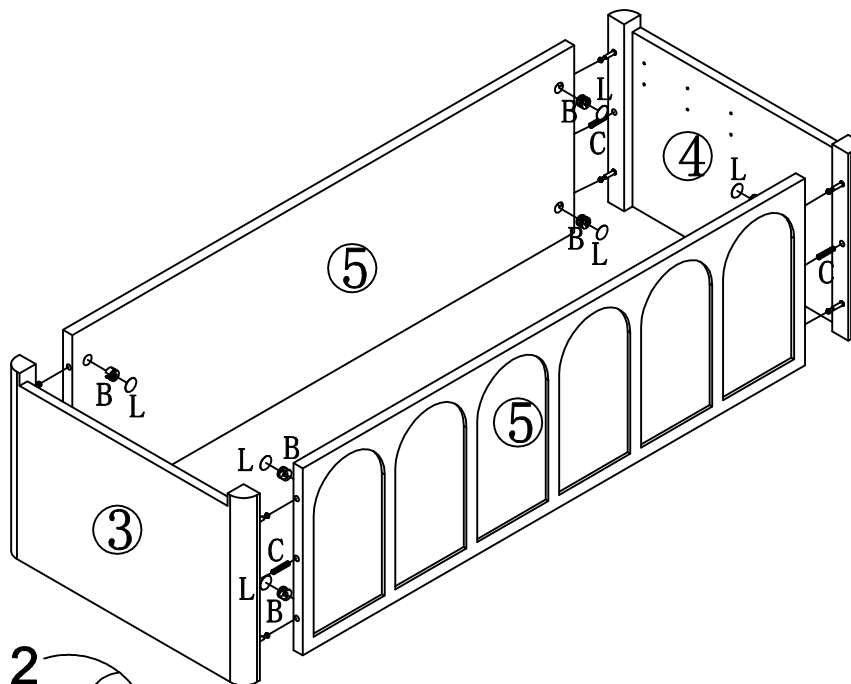
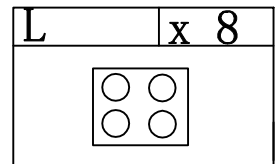
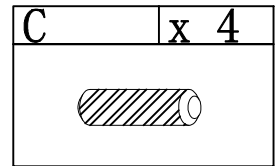
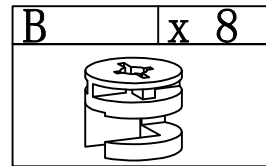

Step 3

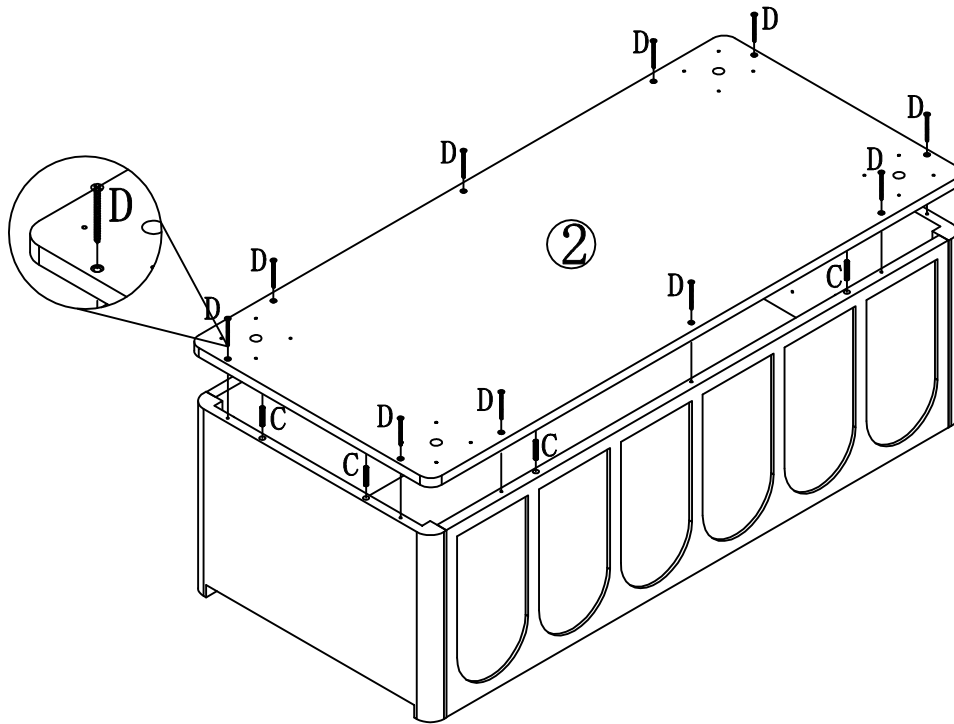
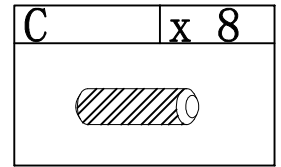
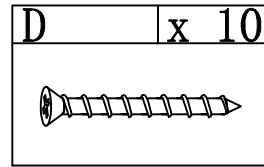

Step 4

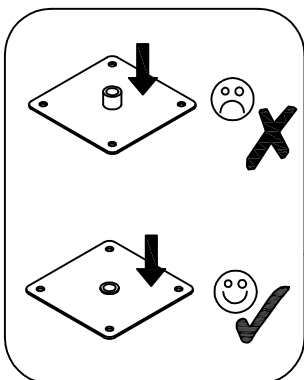
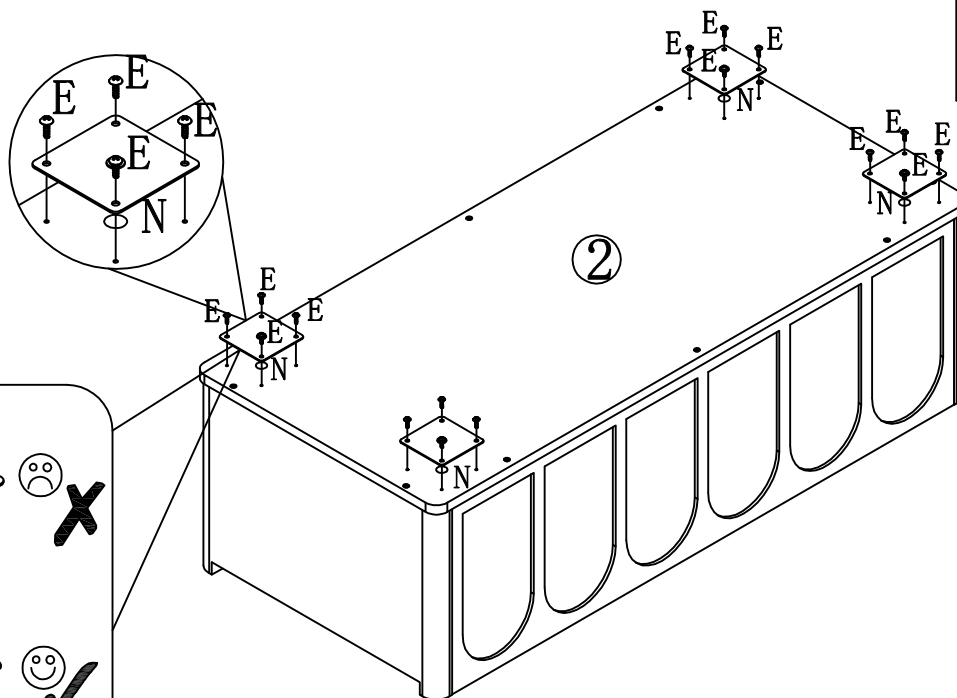
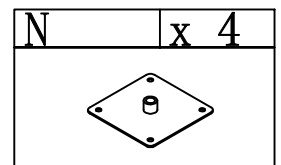
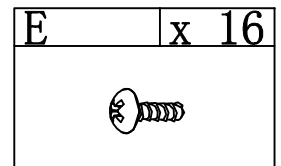

Step 5

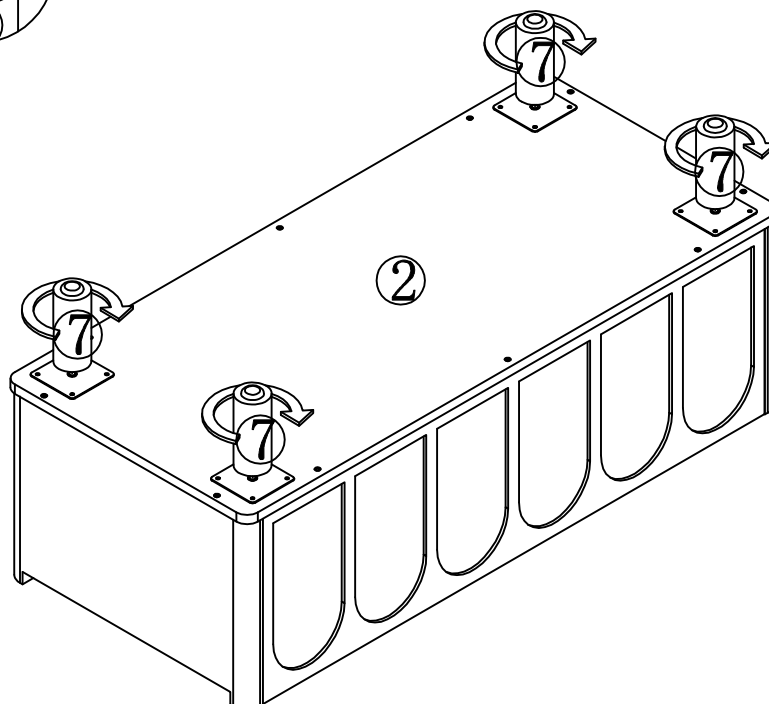
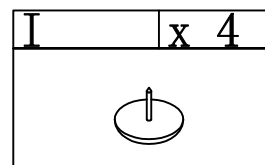
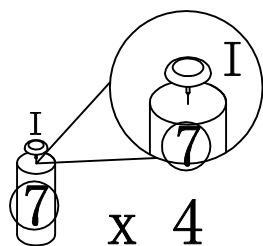

Step 6

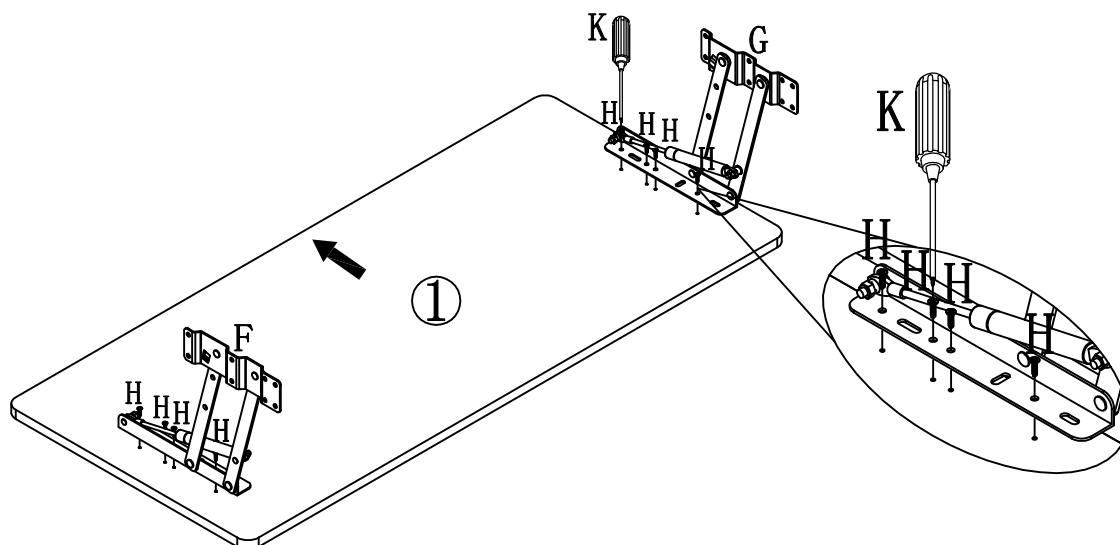
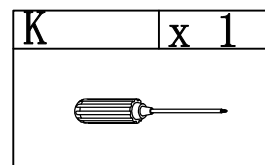
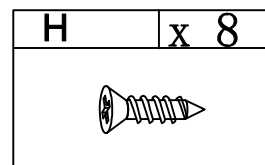
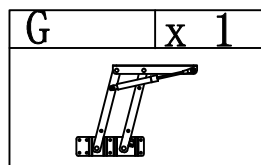
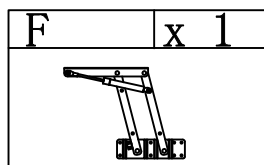

Step 7

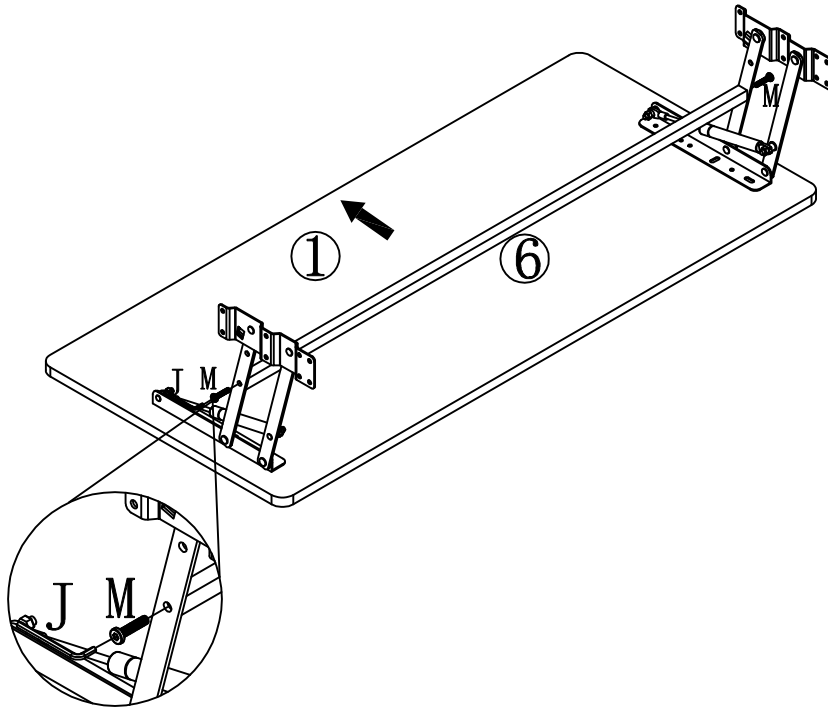
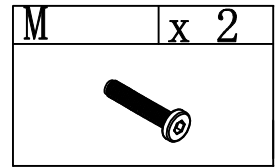
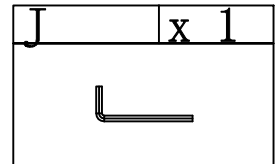

Step 8

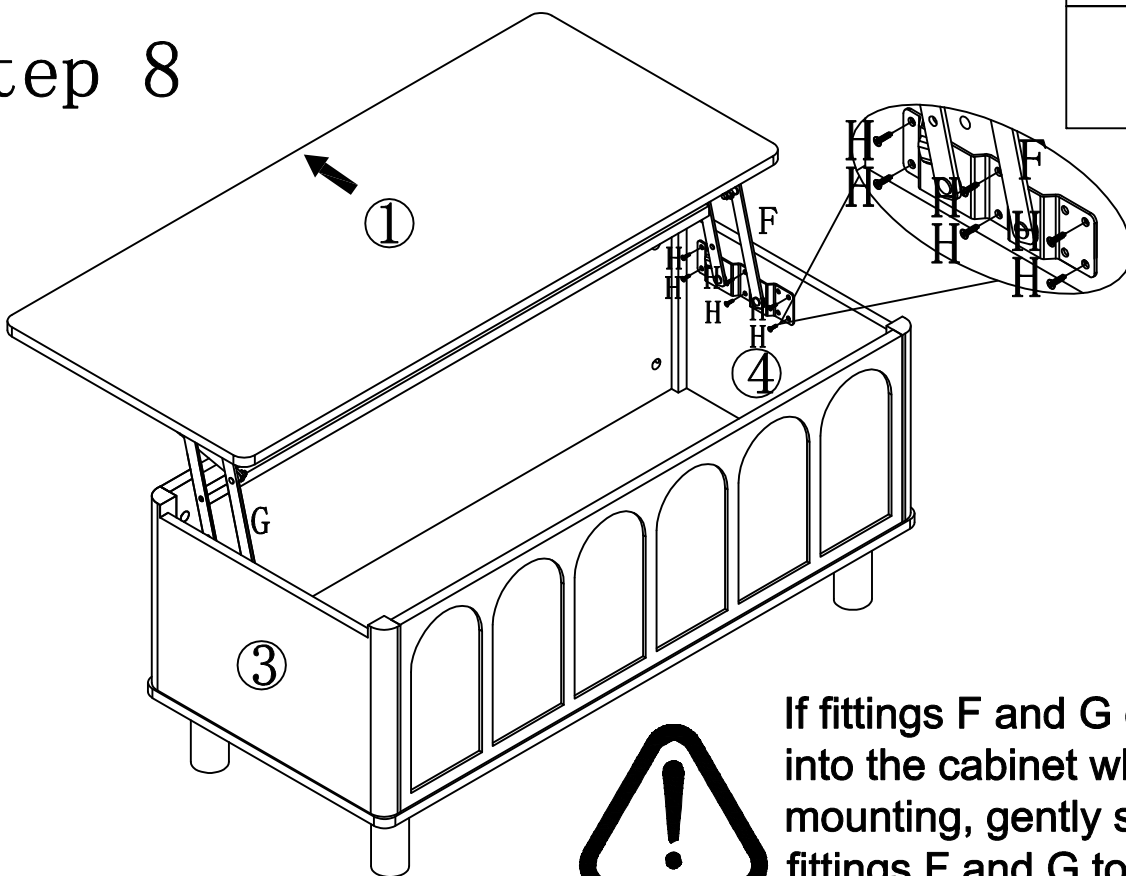
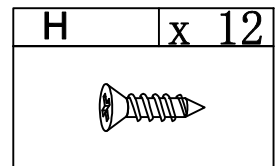

If fittings F and G cannot fit into the cabinet when mounting, gently squeeze fittings F and G to fit into the cabinet

Step 9

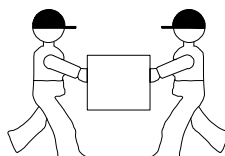
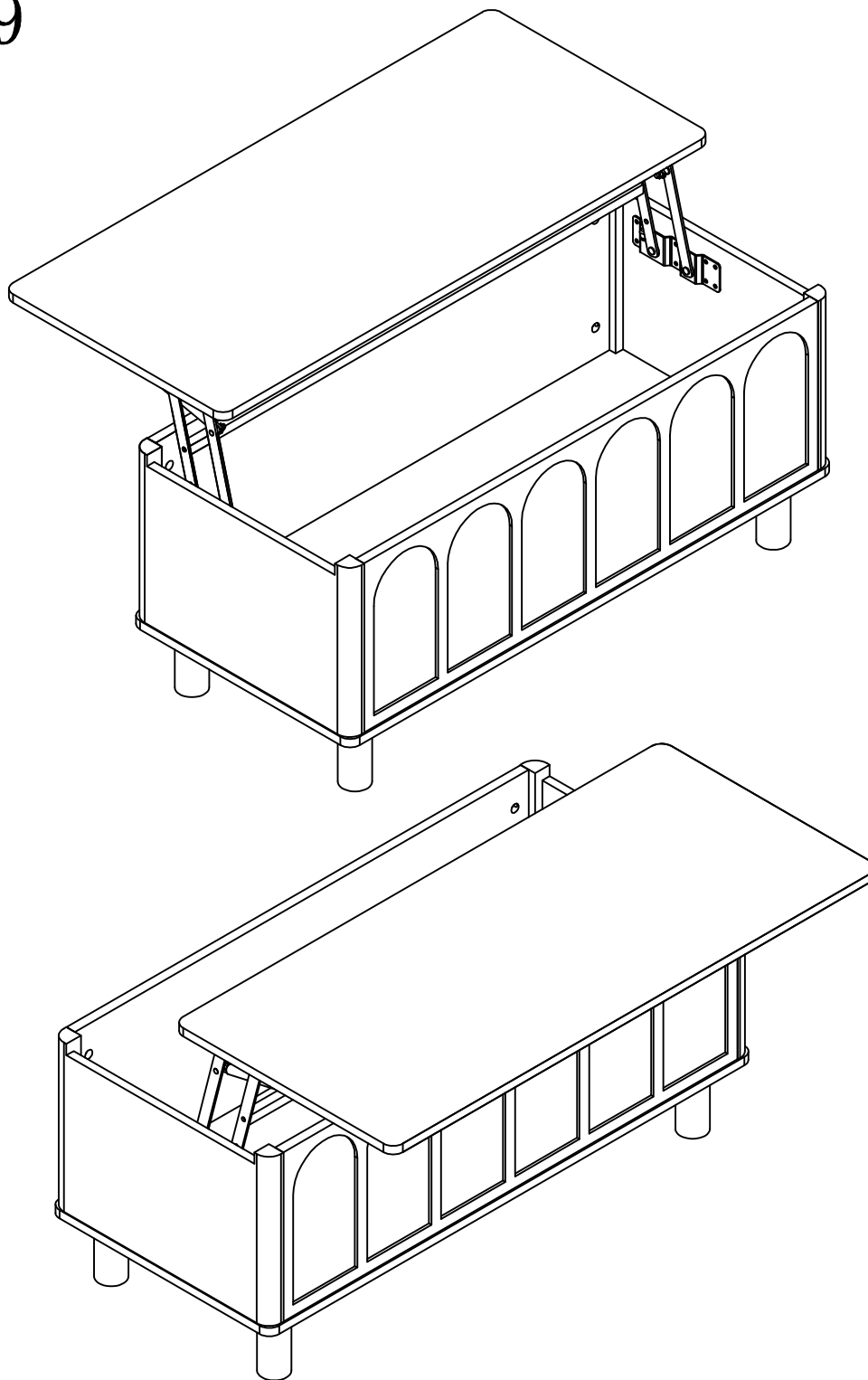

Two people work together to move the table.
Make sure you lift it off the ground.
Don't push and pull.