

# ASSEMBLY INSTRUCTIONS



**CHAISE**

# ITEM:

# ASSEMBLY INSTRUCTIONS

## ASSEMBLY TIPS:

1. Remove hardware from box and sort by size.
2. Please check to see that all hardware and parts are present prior to start of assembly.
3. Please follow attached instructions in the same sequence as numbered to assure fast & easy assembly.



### WARNING!

1. Don't attempt to repair or modify parts that are broken or defective. Please contact the store immediately.
2. This product is for home use only and not intended for commercial establishments.

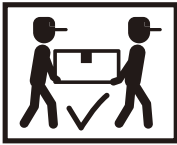

**ASSEMBLY TIME**

**30 MINUTES**

## PARTS IDENTIFICATION

**A CHAISE**



1PC

**C FRONT LEG**



2PCS

**B LARGE PILLOW**

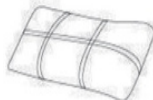

1PC

**D BACK LEG**



2PCS

## HARDWARE IDENTIFICATION

**Z01 SCREW**  
(4 x 25mm - BLK)



16PCS

**Z03 WASHER**  
(8 x 19mm - BLK)



6PCS

**Z02 BOLT**  
(6 x 30mm - BLK)



6PCS

**Z04 WRENCH**  
(D 4mm - BLK)



1PC

## STEP 1

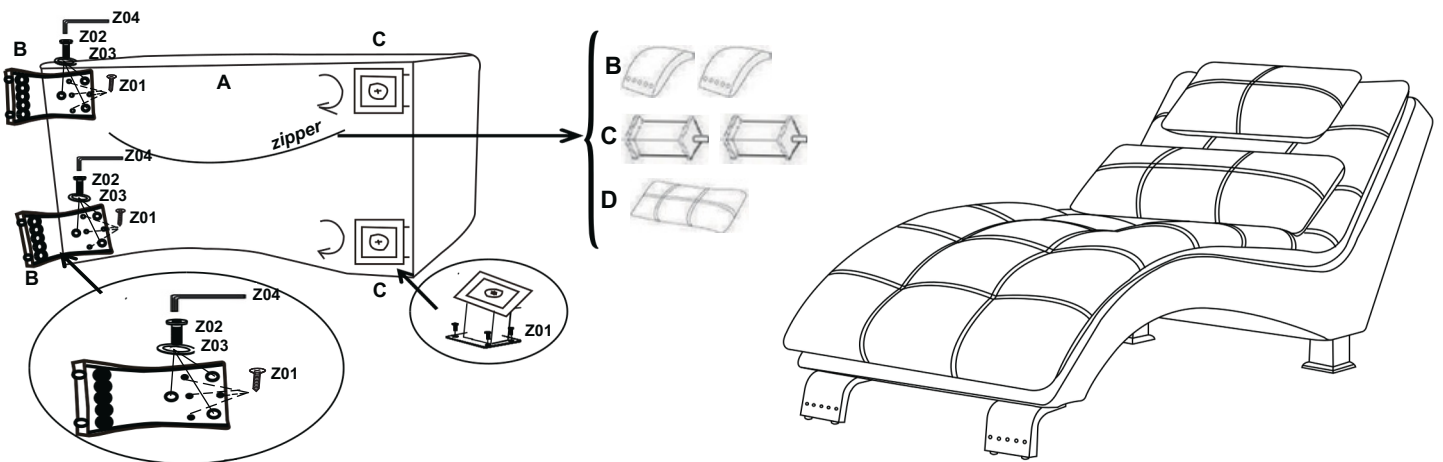

# ASSEMBLY INSTRUCTIONS

## PRODUCT DIMENSION (Note : Dimension tolerance $\pm 5\%$ )

