

# Assembly Manual

## Round Chair

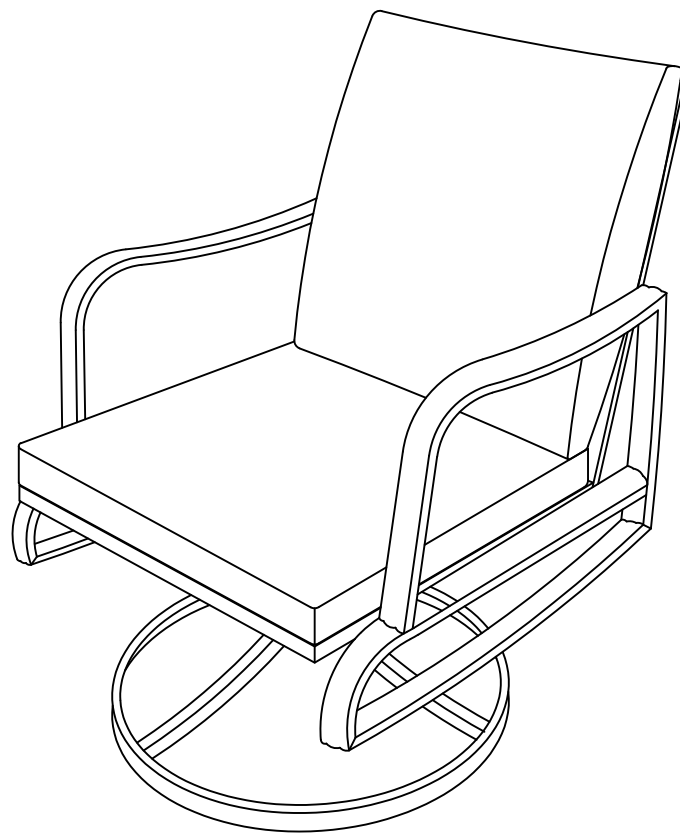





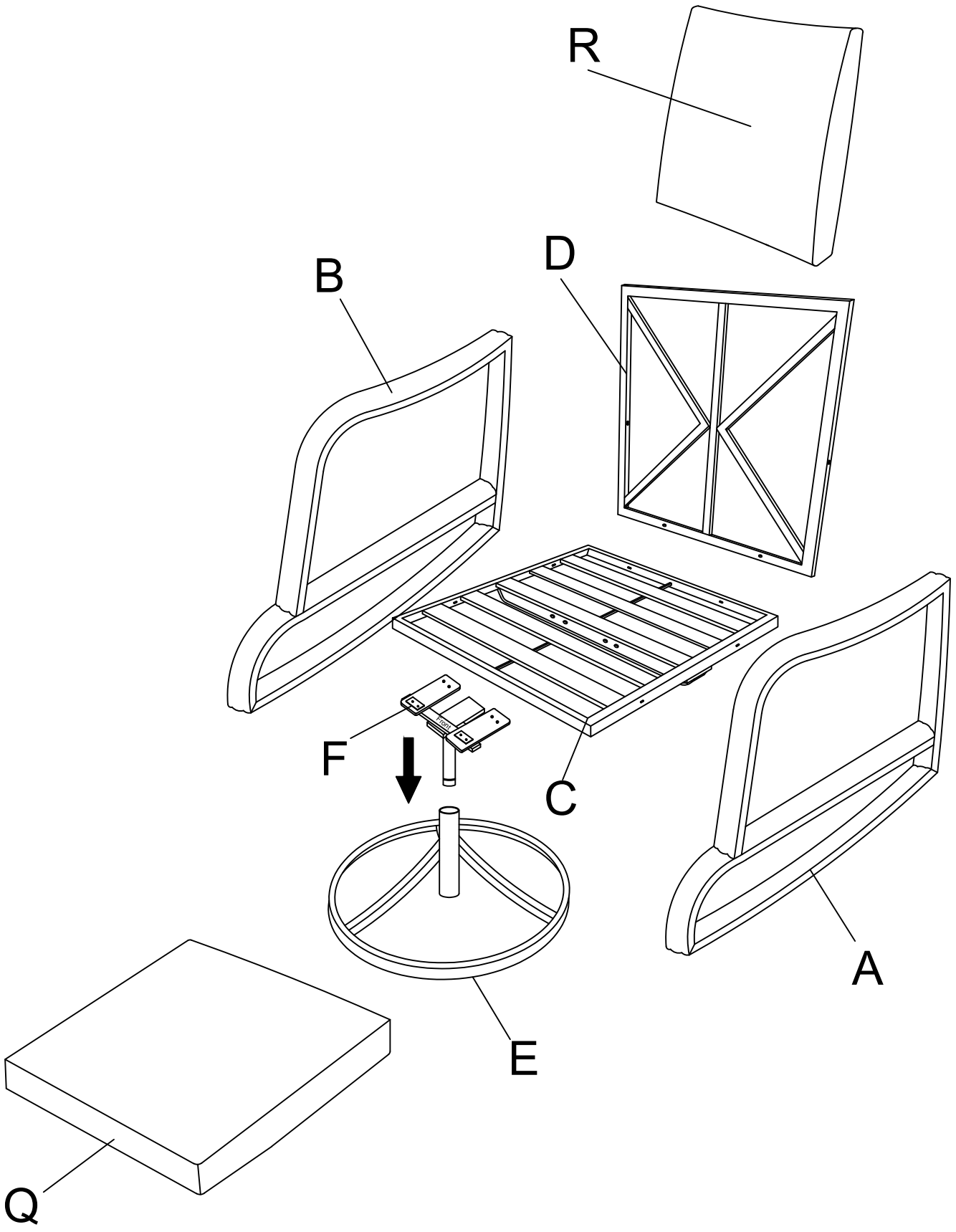

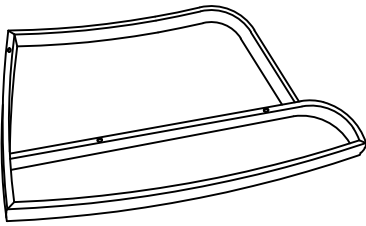
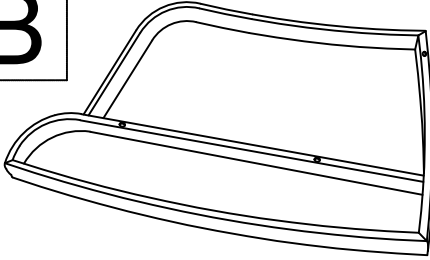
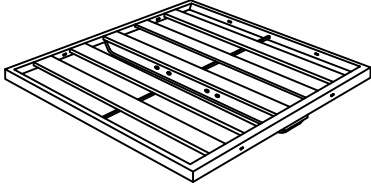
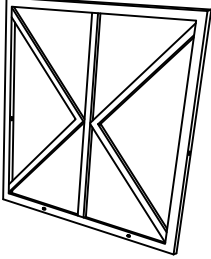
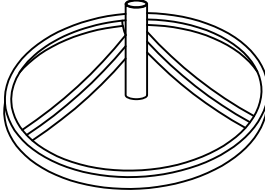
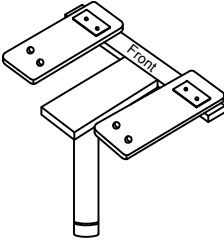

Please read this manual carefully before any operation and keep it properly for future use.

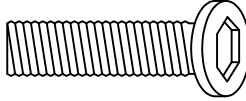
If any problems on our product, please feel free to contact us.

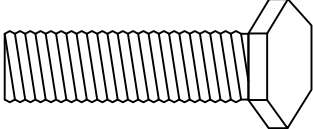

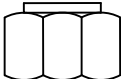
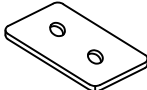

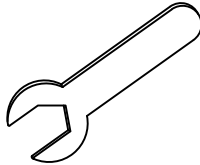
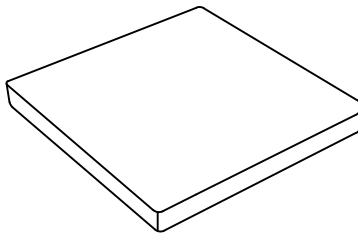
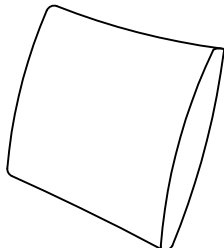

# Components List

<b>A</b>  Left Armrest 2PCS	<b>B</b>  Right Armrest 2PCS	<b>C</b>  Seat 2PCS
<b>D</b>  Back 2PCS	<b>E</b>  Base 2PCS	<b>F</b>  Rotating plate 2PCS
<b>G</b>  Bolt M6X30 14PCS	<b>H</b>  Bolt M6X40 5PCS	<b>I</b>  Washer M6 19PCS
<b>J</b>  Bolt M8X45 9PCS	<b>K</b>  Washer M8 9PCS	<b>L</b>  Spring Washer M8 9PCS
<b>M</b>  Nut M8 9PCS	<b>N</b>  Small iron piece 50*25*3 5PCS	<b>O</b>  Allen wrench M6 1PC
<b>P</b>  wrench M8 2PCS	<b>Q</b>  Seat Cushion 2PCS	<b>R</b>  Back Cushion 2PCS

# ASSEMBLY INSTRUCTION

## Step 1



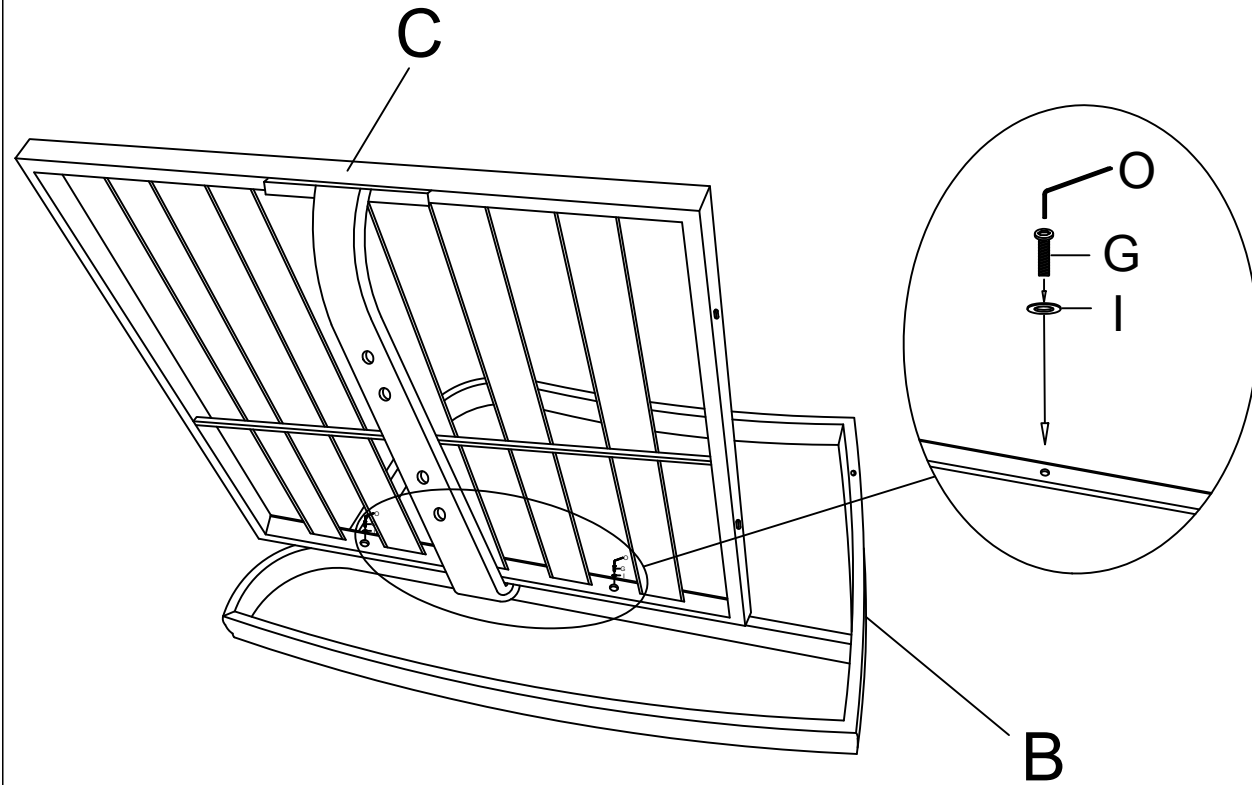

Attach right armrest(B) to the seat board(C) using washers(I), bolts(G) and Allen wrench(O). **Hand-tighten all screws to about 80% first. After all screws are in place, tighten them fully in sequence**

	BX1
	CX1
	GX2
	IX2
	OX1



## Step 2

Attach back frame(D) to the seat frame using washers(I), bolts(G&H), and Allen wrench(O). **Hand-tighten all screws to about 80% first. After all screws are in place, tighten them fully in sequence**

	DX1
	GX2
	HX1
	IX3
	OX1

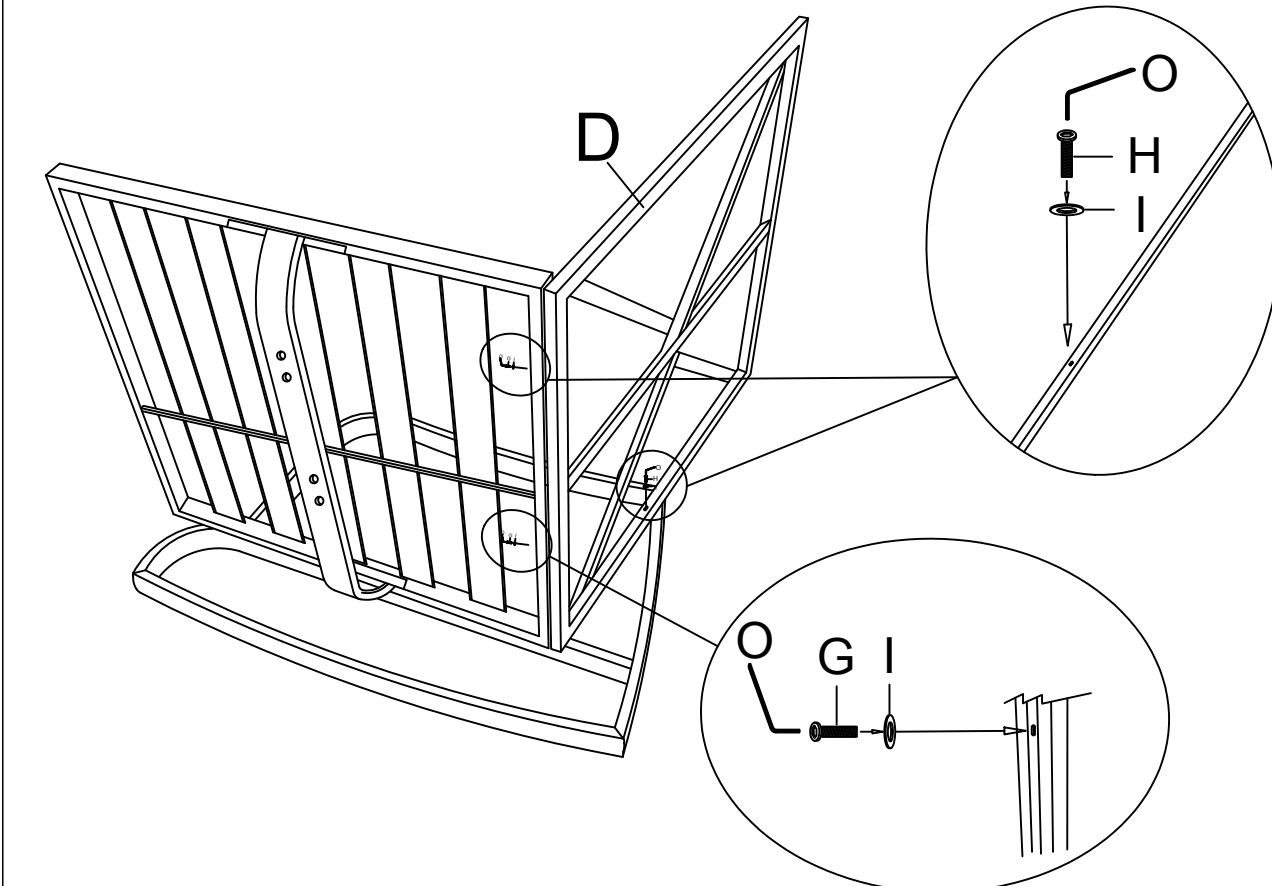

# ASSEMBLY INSTRUCTION

**Step 3** Attach left armrest(A) to the seat board(C) using washers(I), bolts(G&H) and Allen wrench(O). **Hand-tighten all screws to about 80% first. After all screws are in place, tighten them fully in sequence**

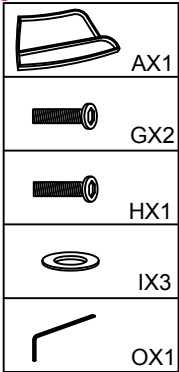
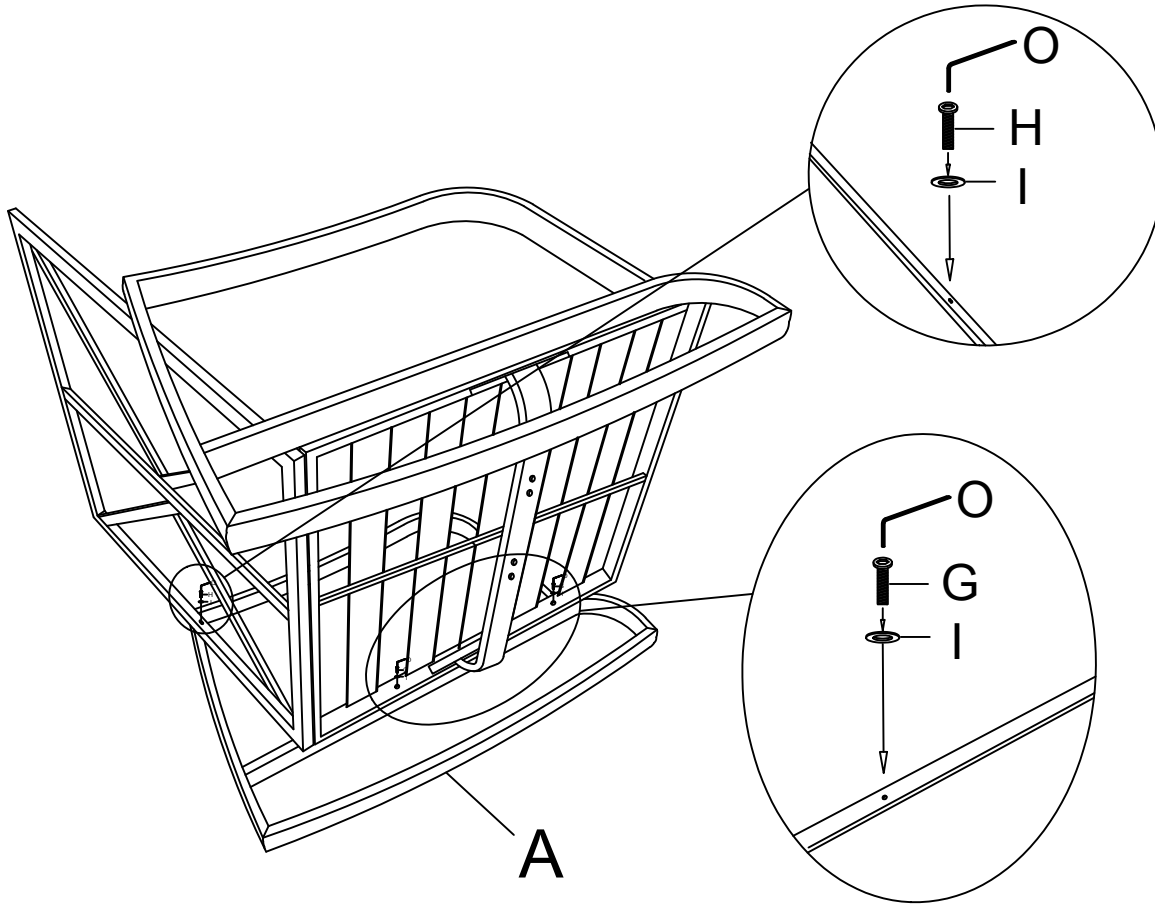



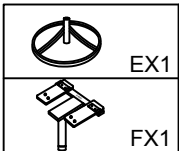
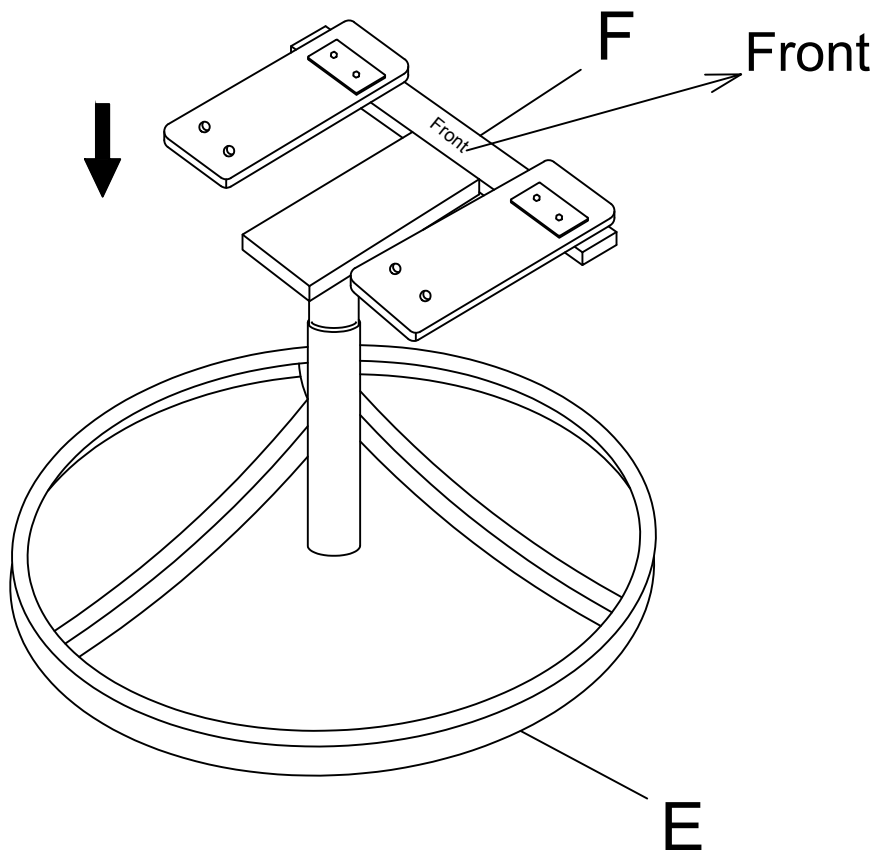



**Step 4** Attach rotate board(F) to the base(E).





# ASSEMBLY INSTRUCTION

**Step 5** Attach seat frame to the base using nuts(M), spring washers(L), washers(K), iron plates(N), bolts(J) and wrench(P).

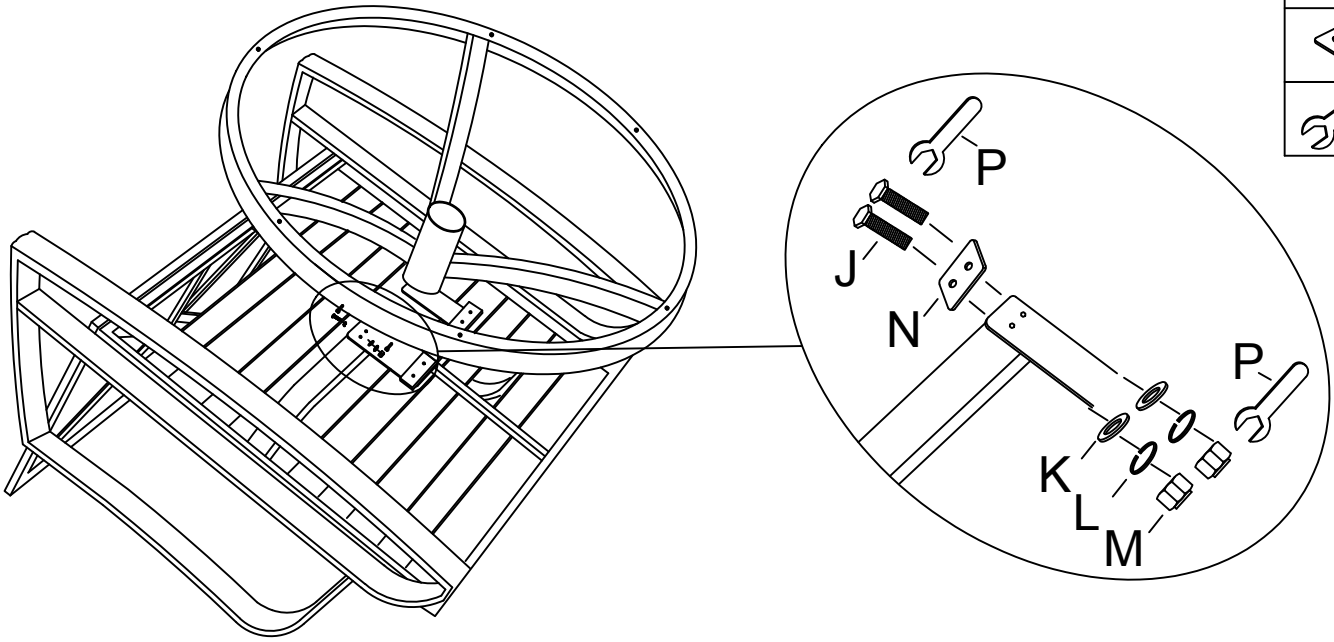
	JX4
	KX4
	LX4
	MX4
	NX2
	PX2

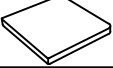

**Step 6** Tighten all bolts 100%, and flip the seat over. Put the seat cushion(Q) and back cushion (R) on the seat frame. The assembly is done.

	QX1
	RX1

