

# ASSEMBLY INSTRUCTION

## DEAR CUSTOMER

Thank you for purchasing our product. Please read this assembly instruction carefully before assemble and use, and keep it for future reference.

## Tips:

1. Please check whether the outer packaging is intact before opening to avoid damage during transportation.
2. Assemble this product on a flat and clean surface to avoid scratching. It is recommended for one or two people to assemble.
3. After unpacking, please confirm in time all the parts and hardware are included. Please do not discard any packaging, if for any reason you need to return this product, it must be returned in its original packaging.
4. If you have any questions about the products, please send an email to on the website!
5. Please keep small parts out of reach of children or pets to prevent them from swallowing.
6. Please read the installation steps in the Instruction carefully and follow the steps in the Instruction to assemble.

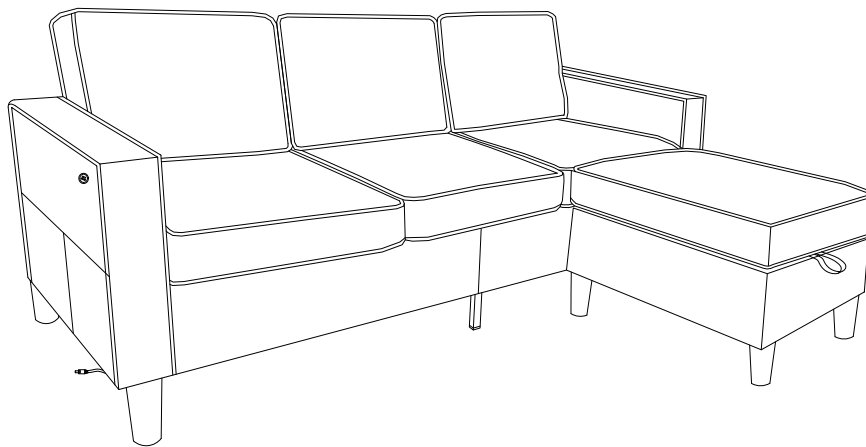

# Unpacking Step

## First layer

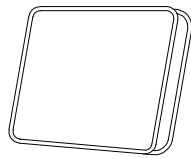
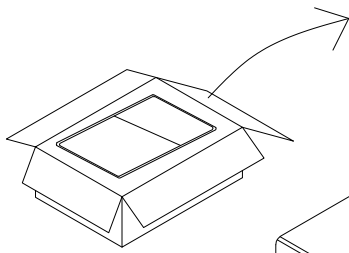

(D) Back Cushion

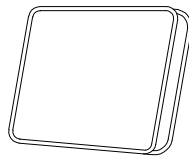

(D) Back Cushion

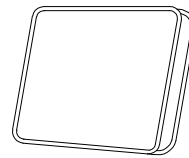

(D) Back Cushion

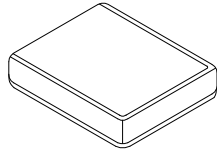

(E) Seat Cushion

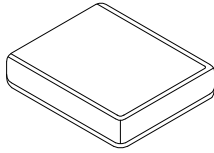

(E) Seat Cushion

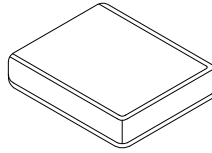

(E) Seat Cushion

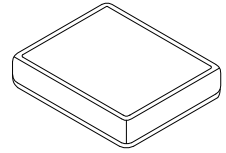

(F) Seat Cushion Of Ottoman

## Second layer

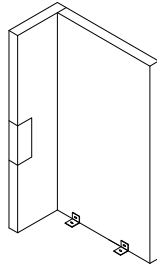
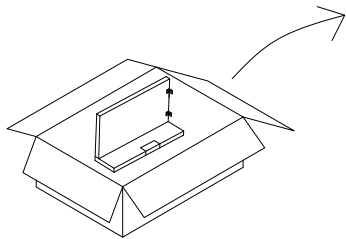

(C1) Left Seat Frame

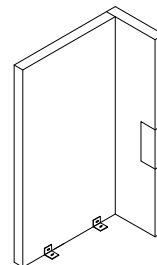

(C2) Right Seat Frame

## Third layer

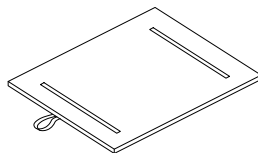
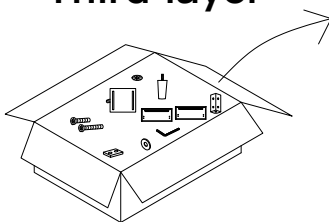

(G) Cover Panel



(H) Front/Back Panel



(I) Side Panel



(K) Leg



(O) Angle Iron



(P) Anti-slip Gasket

## Hardware Bag:

(Q) Bolt



(R) Bolt

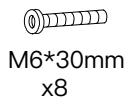

(S) Connections



(T) Flat Washer



(U) Allen Wrench

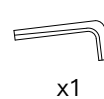

(V) USB



# Unpacking Step

Fifth layer

The parts(B/B1/B2/J/L/M) are hidden in left/right armrest

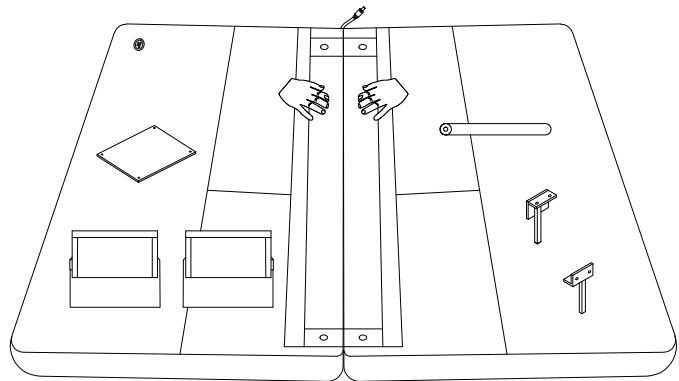
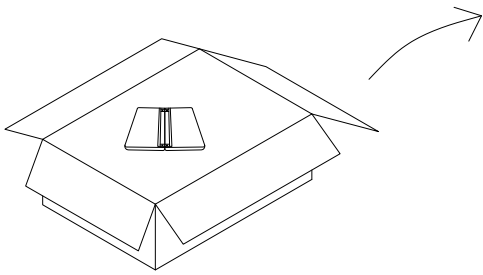

(A1) Left Armrest

(A2) Right Armrest

**STEP 1** Open the left/right armrest (A1/A2) ,pull out the parts (B/B1/B2/J/L/M) which are hidden in them.

(A1) Left Armrest

(A2) Right Armrest

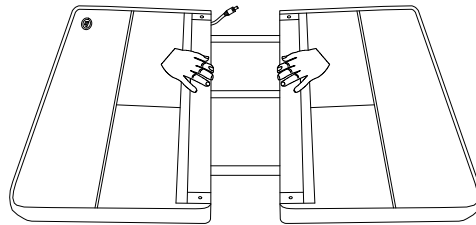

(B1) Back Frame

(B) Metal Pipe

(B2) Back Frame

(J) Base Panel

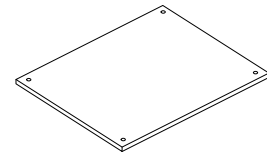
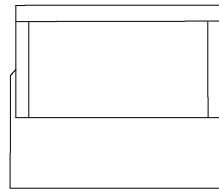
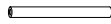
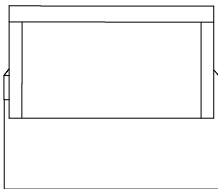

(L) Mid-Leg

(M) Mid-Leg

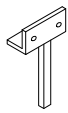
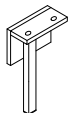

**STEP 2** First screw the angle irons (O) on the front/back panel (H) using the bolts (Q) and the allen wrench (U), then screw the angle irons (O) on the side panels (I) using the bolts (Q) and the allen wrench (U).

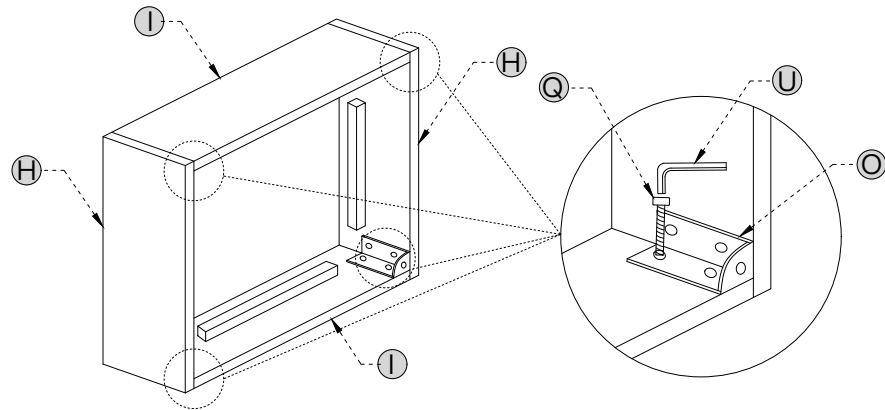
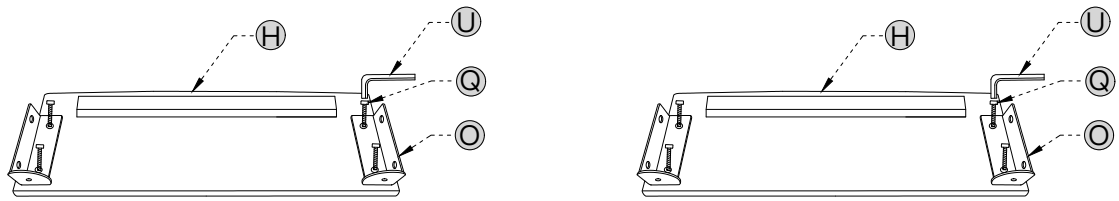

H		x2
I		x2
O		x4
Q		x16 M6x18mm

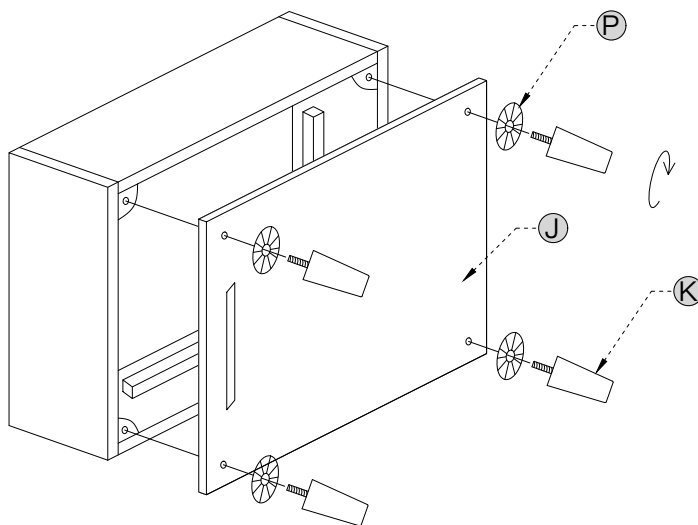

**STEP 3** Insert the bolts on the Legs (K) into the anti-slip gaskets (P) and the base panel (J), and tighten them onto the ottoman.



P		x4
J		x1
K		x4

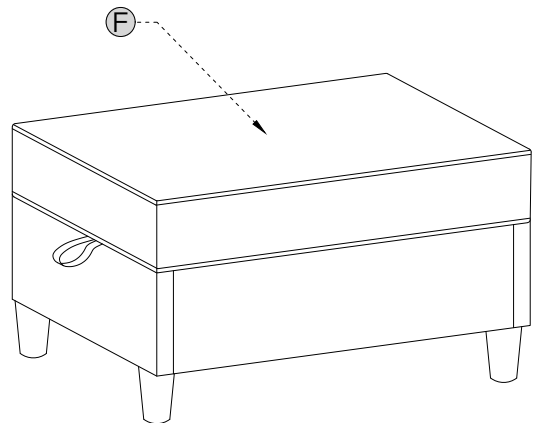
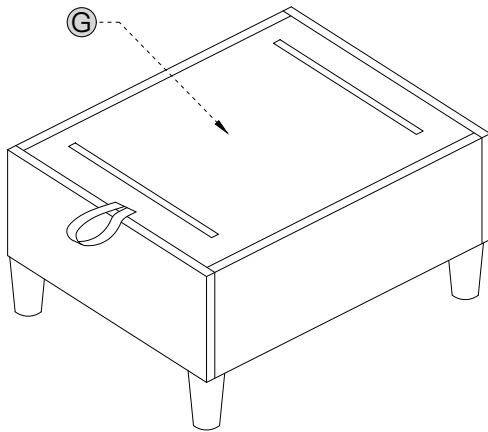



**STEP 4** Put on the cover panel (G) and the seat cushion (F) on the ottoman.

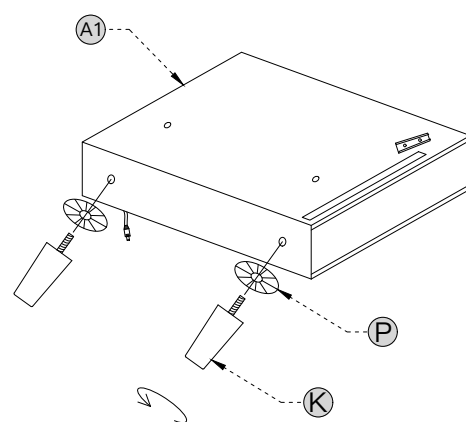
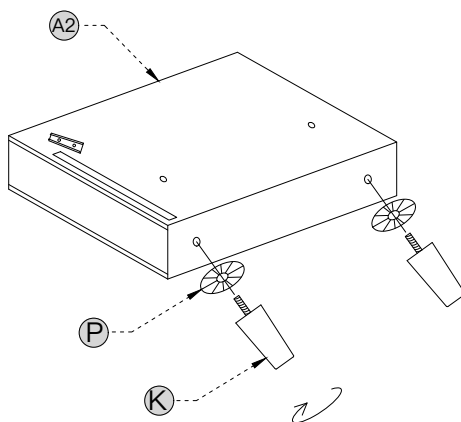

G		x1
F		x1

**STEP 5** Put the anti-slip gaskets (P) into the legs (K) and tighten them on the left/right armrest (A1/A2).



A1		x1
A2		x1
P		x4
K		x4

**STEP 6** Screw the left/right seat frame (C1/C2) onto the left/right armrest (A1/A2) using the bolts (R), the flat washers (S) and allen wrench (U).

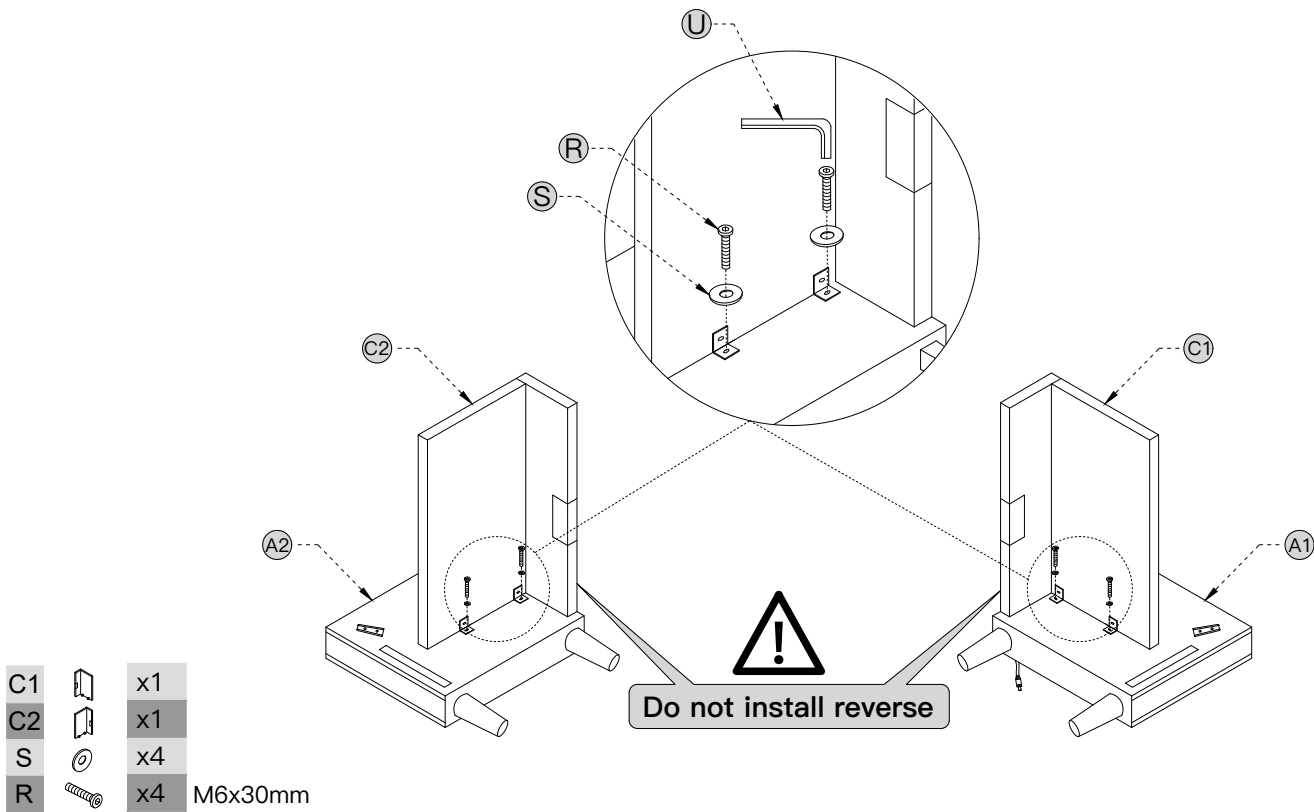

**STEP 7** Fasten the left and right seat frames (C1/C2) with connectors (L/M) using bolts (Q/R), flat pads (S), and Allen wrench (U).

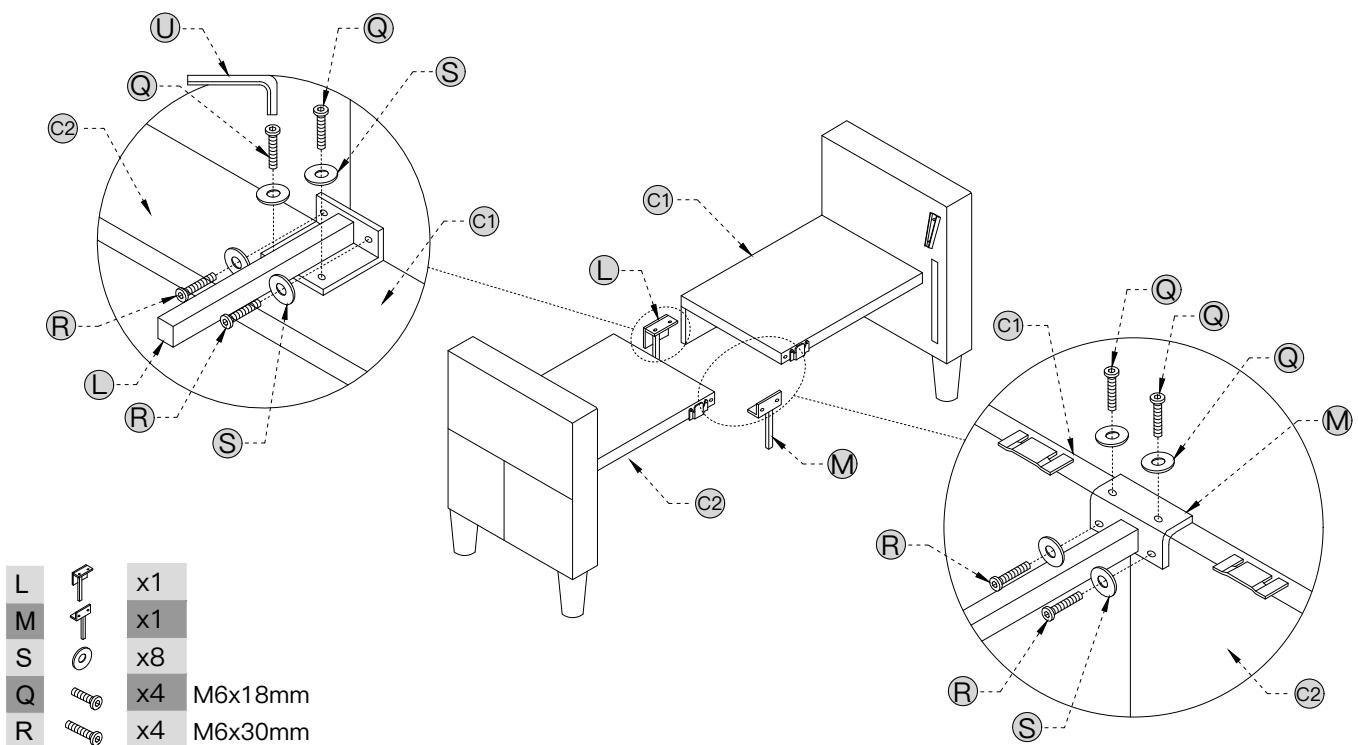

**STEP 8** Use a metal pipe (B) to connect the two back frames (B1/B2) together.

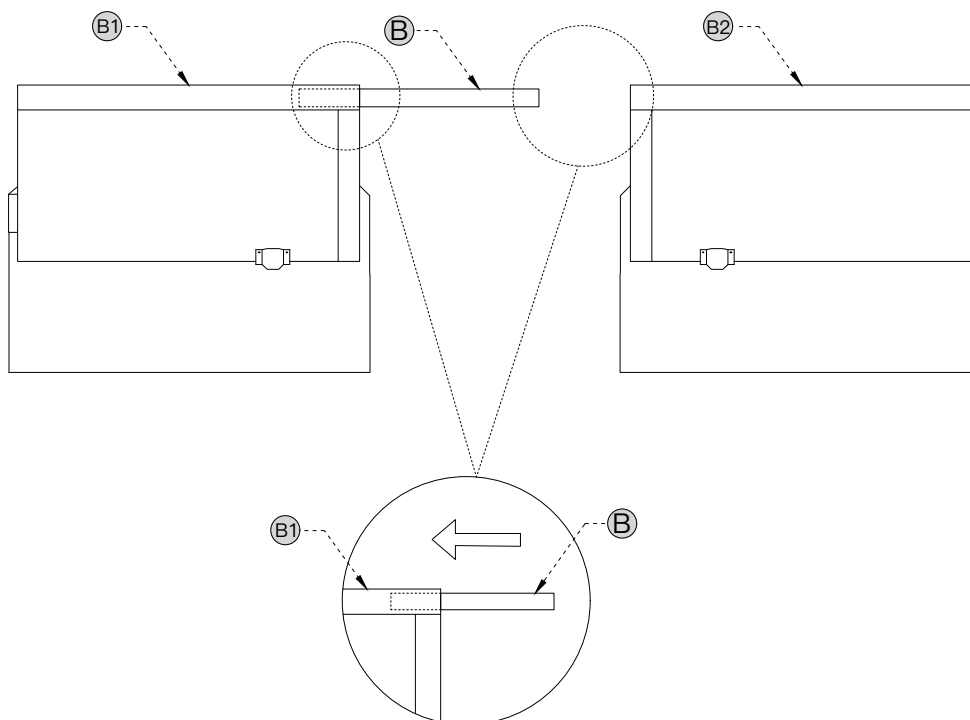

B1		x1
B2		x1
B		x1

**STEP 9** After connecting the two back frames (B1/B2) together with a metal tube (B), use the connector (T) and the bolt (Q) to secure the two back frames (B1/B2) together.

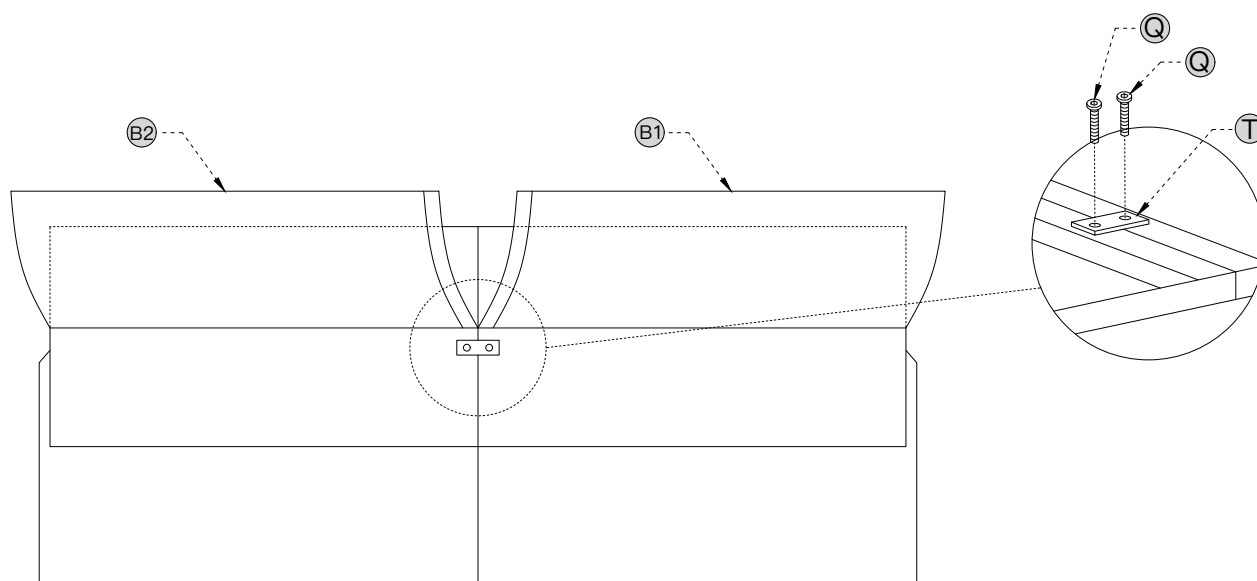

T		x1
Q		x2 M6x18mm

**STEP 10** Secure the back frame (B1/B2) to the left and right armrest (A1/A2) and the seat frame (C1/C2).

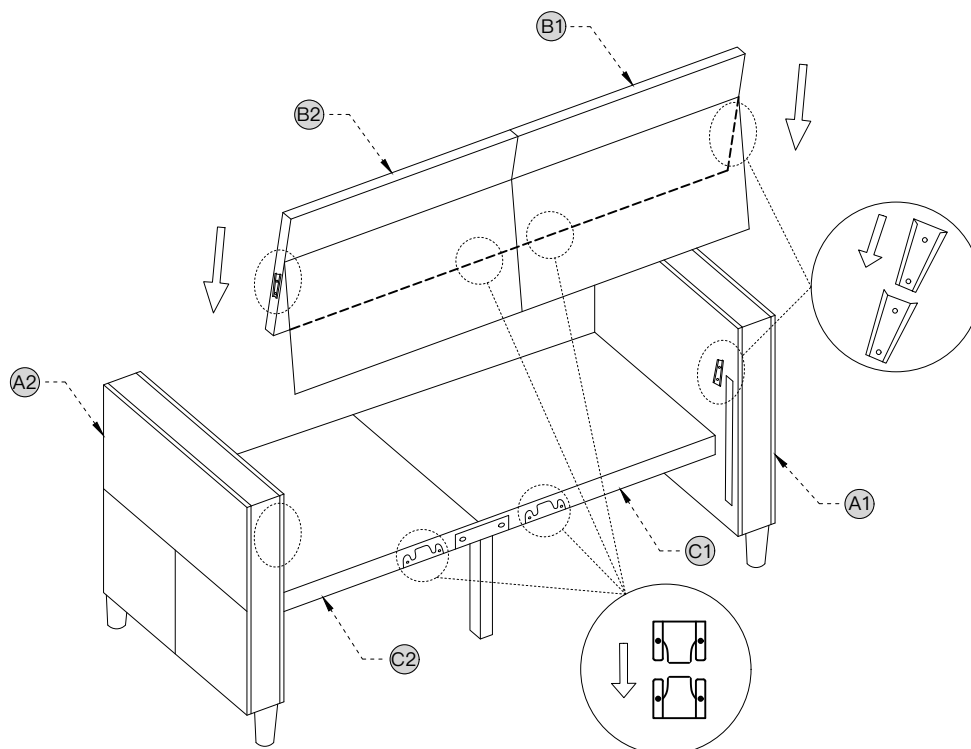

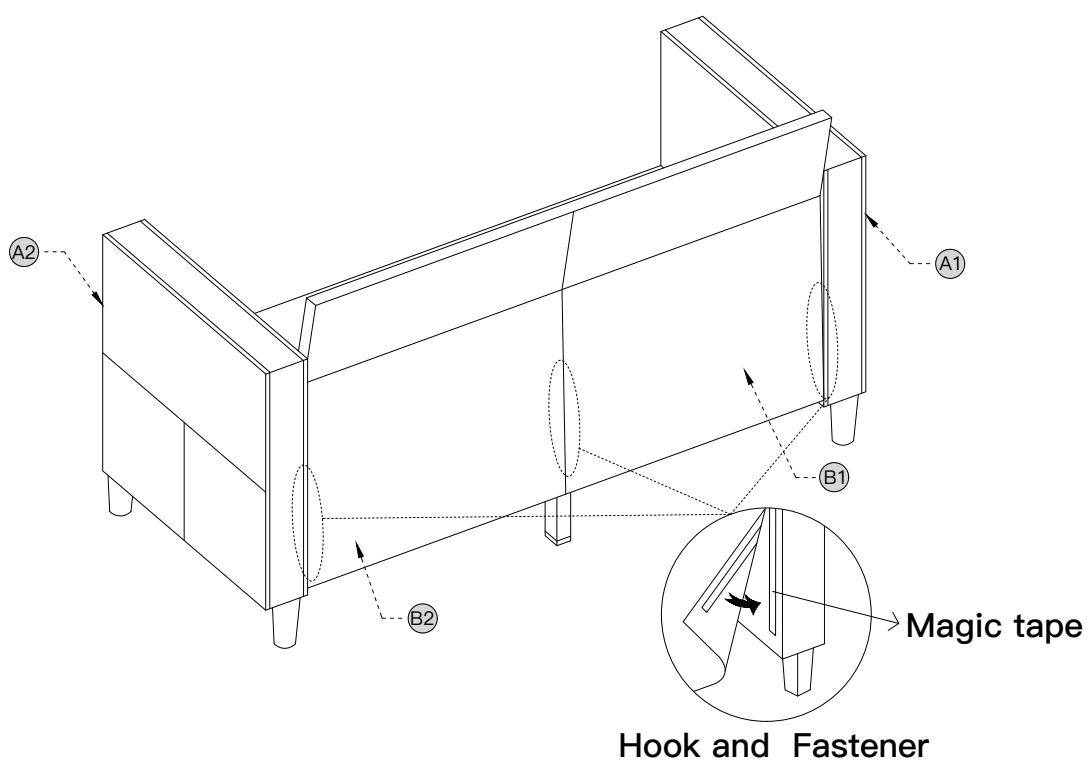

**STEP 11** Attach the cloth cover (B1/B2) and the left/right armrest (A1/A2) together by the hook and loop fastener.

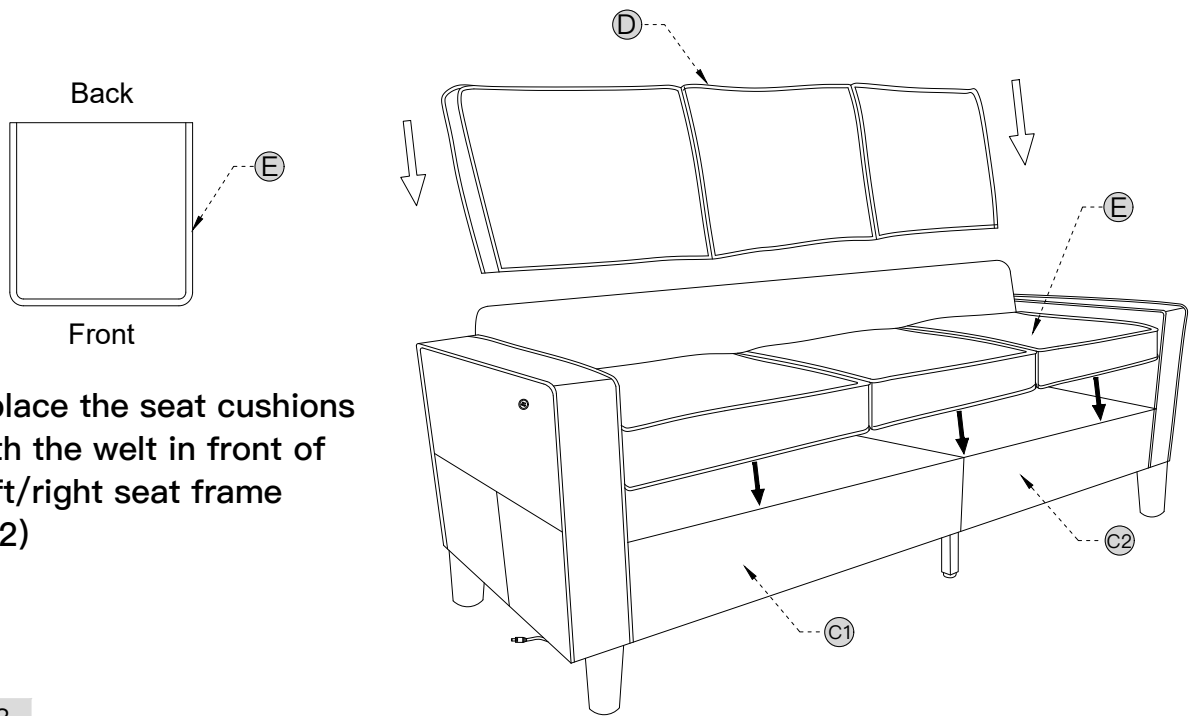

**STEP 12** Put the back cushions (D) and the seat cushions (E) in place.



Note: place the seat cushions (E) with the welt in front of the left/right seat frame (C1/C2)

- |   |   |    |
|---|---|----|
| D |   | x3 |
| E |  | x3 |

**STEP 13** The ottoman can conveniently be placed in front of the sofa. when placing in the both sides, if using, connect the hooks on the sofa to the loop on the ottoman, if not using, fold the hooks to hide in the sofa.

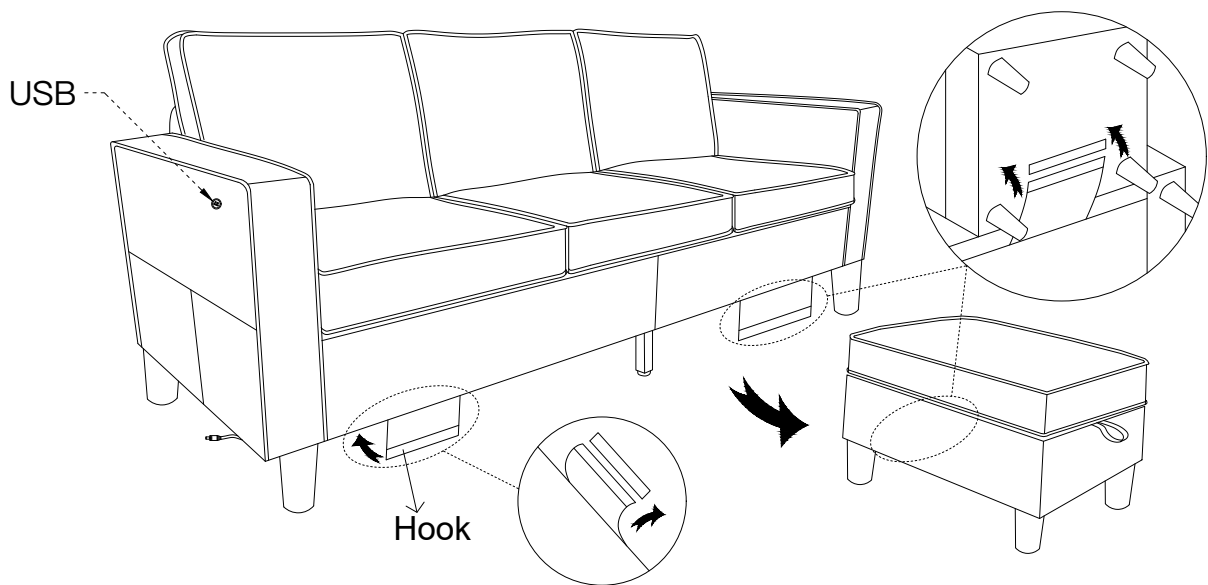

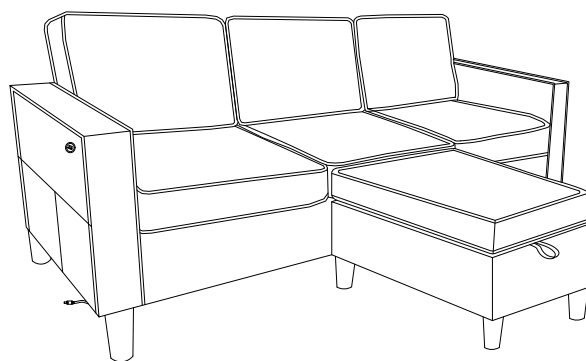
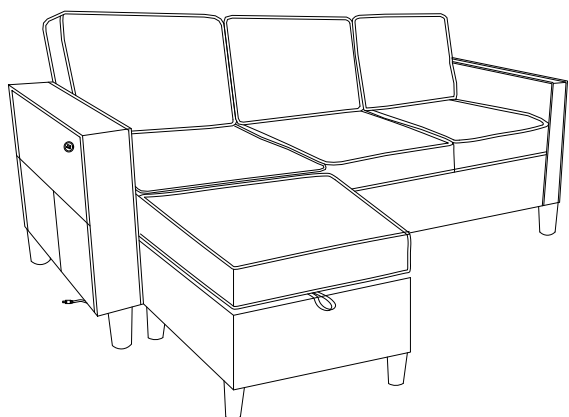

USB

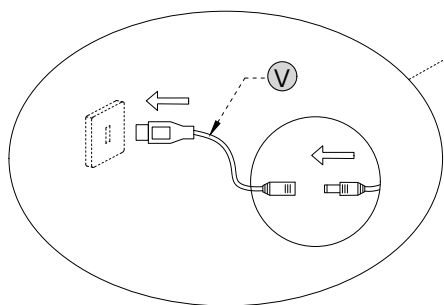
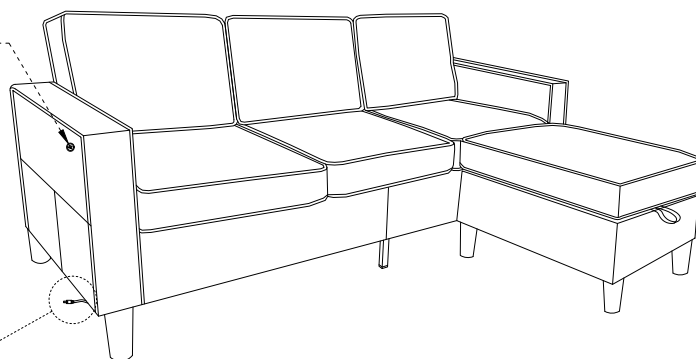

V  x1

# Assembly completed!

Please enjoy your sofa