

# Assembly instructions

## Product code: BW00364AAB

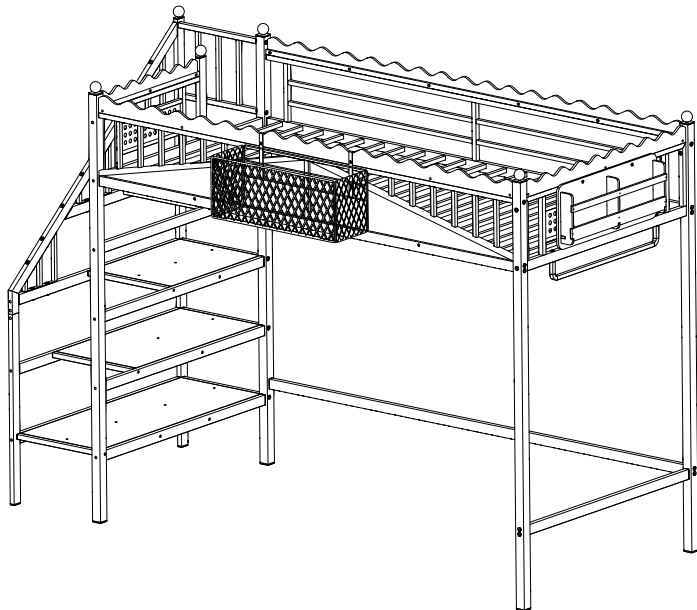
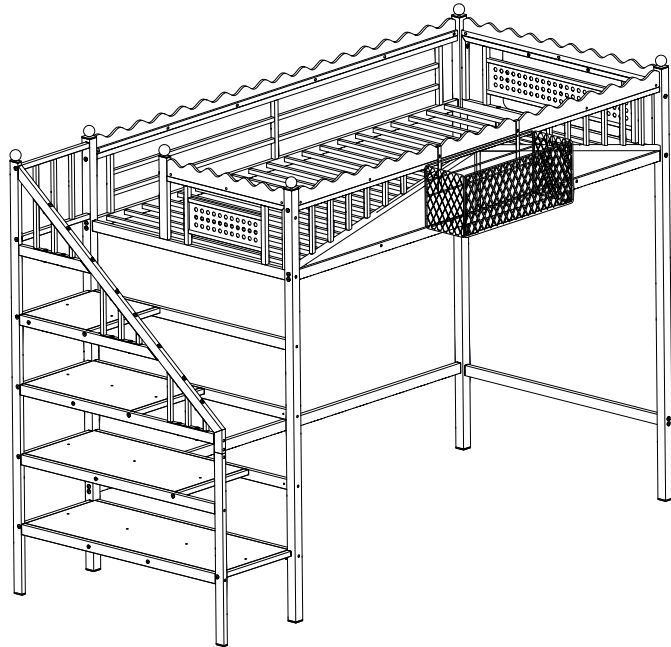

### SAFETY WARNINGS AND GENERAL NOTES:

1. Follow the information on the warnings on the bunk bed end structure and on the carton. Do not remove the warning label from the bed.
  2. Always use the recommended size mattress on mattress support, or both, to help prevent the likelihood of entrapment or falls.
  3. Do not allow children under 6 years of age to use the upper bunk.
  4. Periodically check and ensure the guardrail, ladder and other components are in their proper position, free from damage, and all connectors are tight.
  5. Do not allow horseplay on or under beds.
  6. Always prohibit jumping on the bed.
  7. Prohibit more than one person on upper bunk.
  8. Always use the ladder for entering and leaving the upper bunk.
  9. Do not use substitute parts. Contact the manufacturer or dealer for replacement parts.
  10. Use of a night-tight may provide added safety precaution for a child using the upper bunk.
  11. Always use guardrails on both long sides of the upper bunk.
  12. If the bunk bed will be placed next to a wall, the guardrail that runs the full length of the bed should be placed against the wall to prevent entrapment between the bed and the wall.
- The use of water or sleep flotation mattresses is prohibited.
13. **STRANGULATION HAZARD**-Never attach or hang items to any part of the bunk bed that are not designed for use with the bed ; for example, but not limited to, hooks, belts and jump ropes.
  14. Keep these instructions for future reference.
  15. We recommend assembling your bunk bed on the shipping carton to protect your floor or carpet.
  16. Be certain all staples are out of the box before beginning assembly on the shipping carton.
  17. USE ONLY MATTRESSES WHICH ARE AS THE TABLE BELOW ON UPPER AND ON LOWER BUNKS.

#### Upper bed

Bed type	Length	Width	Thickness
Twin XL Standard	79" -80"	38 ½"	6" max

18. SURFACE OF MATTRESS MUST BE AT LEAST 5"(127MM) BELOW THE UPPER EDGE OF GUARDRAILS.







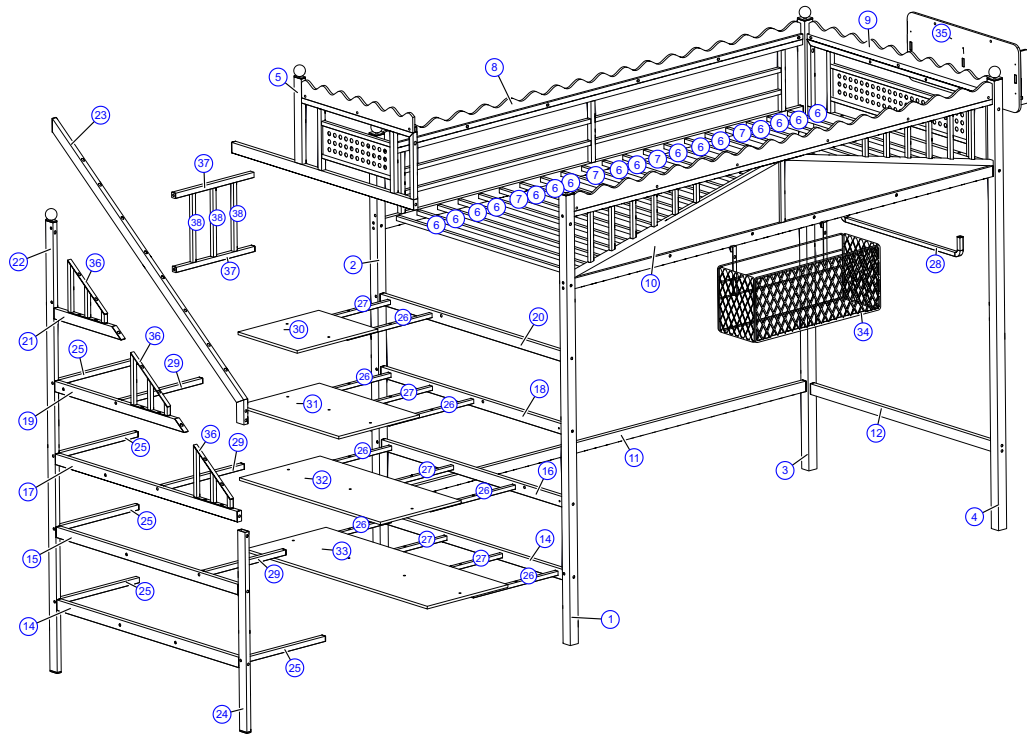



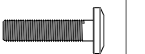



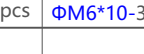

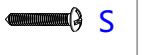

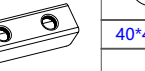
19. Replacement Parts:

Replacement Parts, including additional guardrails, may be obtained from any of our ( Shenzhen Yuefeng Zhiqi Technology Co., Ltd) dealers.



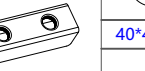







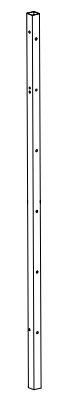

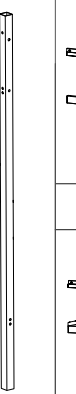
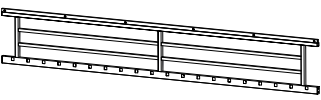
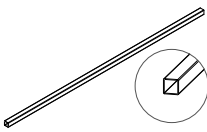
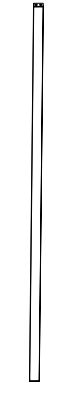
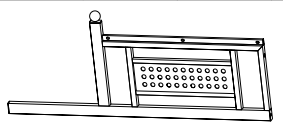
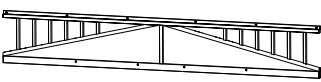
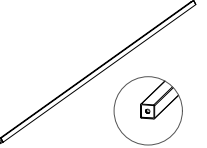
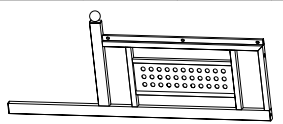
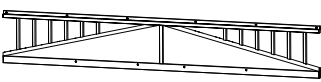
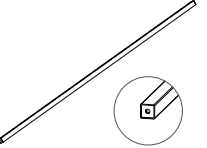
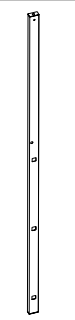
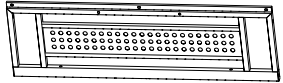
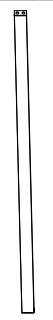







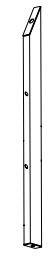

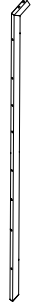
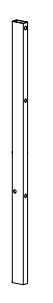
## Component distribution preview

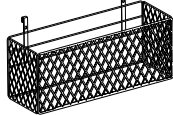

## HARDWARE LIST

						
M8*55-55pcs	M8*35-25pcs	M8*30-8 pcs	ΦM8*16-15pcs	M6*15-18pcs	M6*25-12pcs	ΦM6*10-32pcs
						
40*40FQ-4pcs	M2.6*18-12pcs	20*40-2pcs		40*40M8-6pcs	M5*25-2pcs	
						
40*40F-4pcs	Z-1pcs	20*40-2pcs		18*60 -2pcs	M4*25-2pcs	

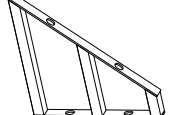
## List of components

						
1-1pcs	2-1pcs	3-1pcs	4-1pcs	8-1pcs	6-16pcs	11-1pcs
						
5-1pcs	10-1pcs	7-4pcs	9-1pcs	12-1pcs	14-2pcs	15-1pcs
						
19-1pcs	20-1pcs	21-1pcs	22-1pcs	23-1pcs	24-1pcs	25-5pcs
						
26-7pcs	27-5pcs	28-1pcs	29-3pcs	34-1pcs	35-1pcs	36-3pcs
						
37-2pcs	38-3pcs					
						

# No. 34 Component List

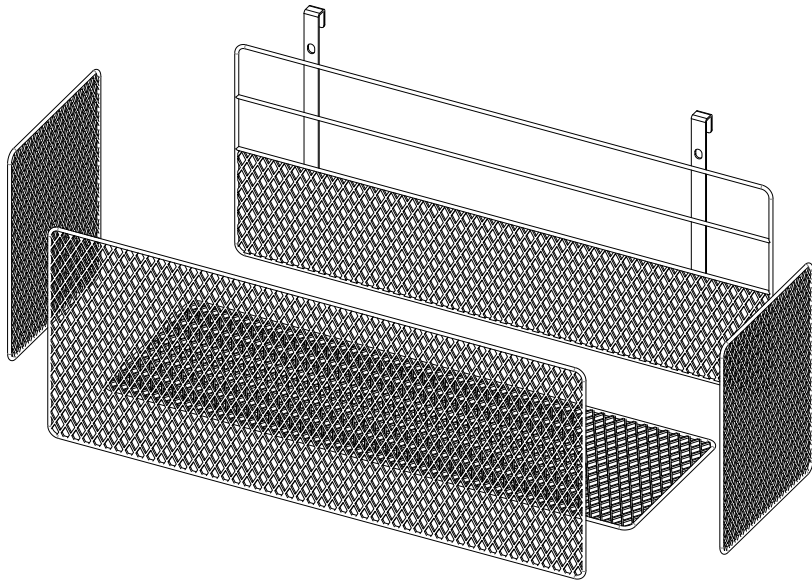

Use a customized tie to bundle all the parts of the No. 34 component together, and use the tool to cut off the tail length of the tie.

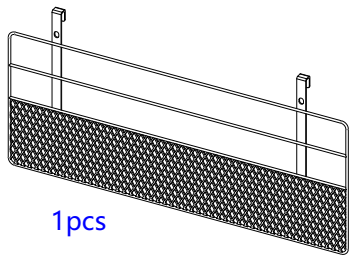
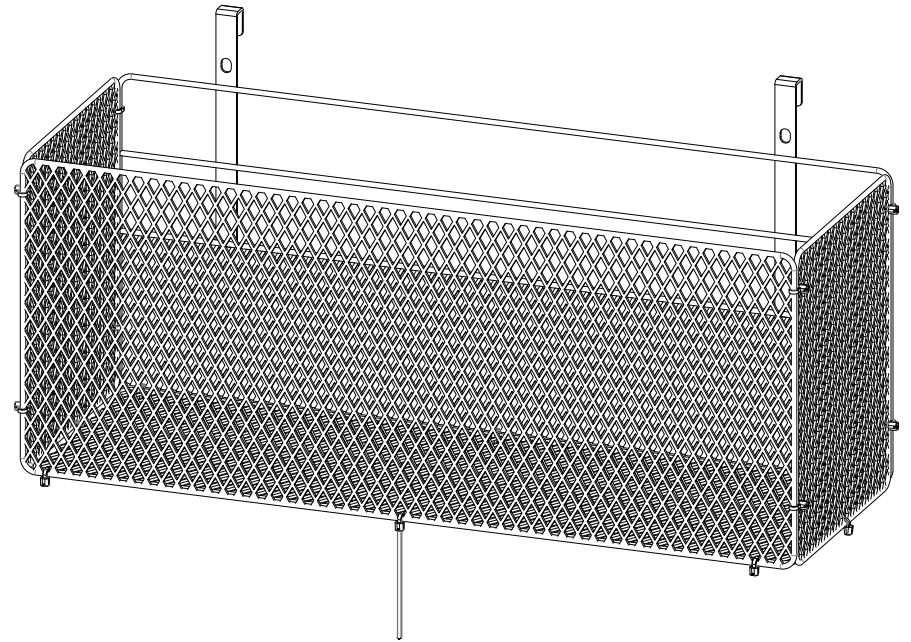

1pcs

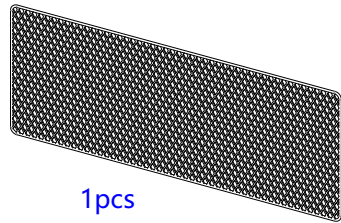

1pcs

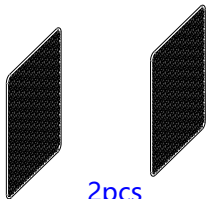

2pcs

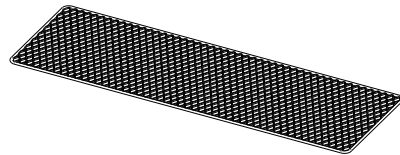

1pcs

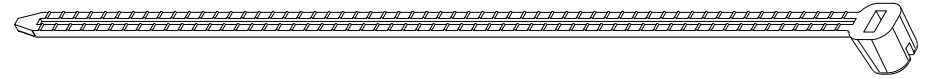

O-16pcs

# No. 35 Component List

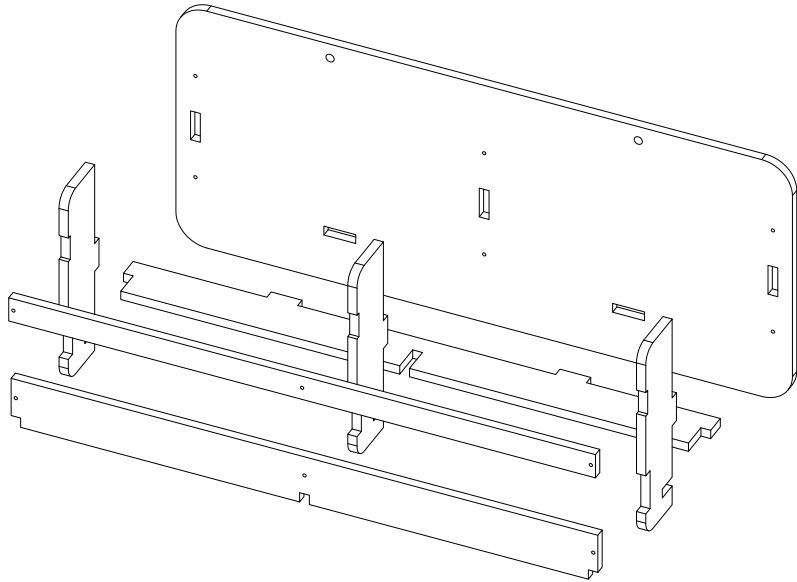

Use screw Z, S accessories to combine the parts required for the No. 35 component.

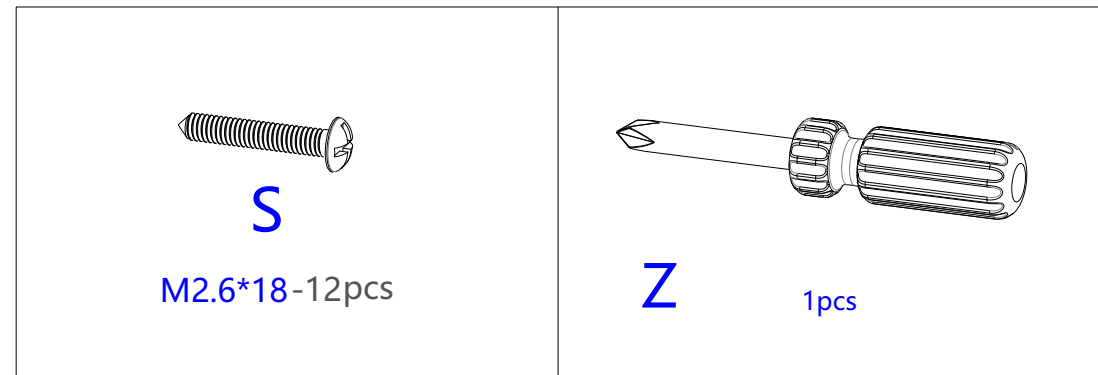
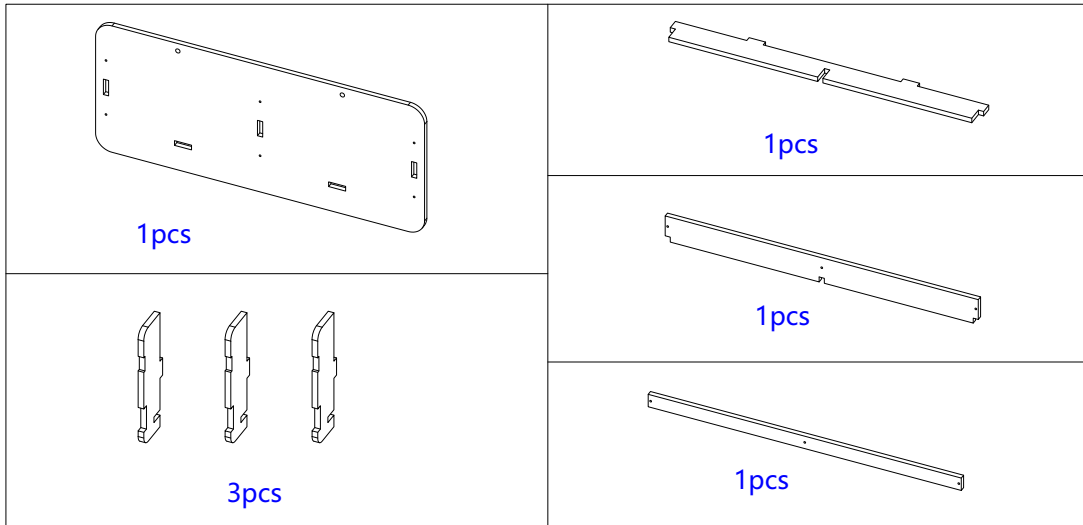
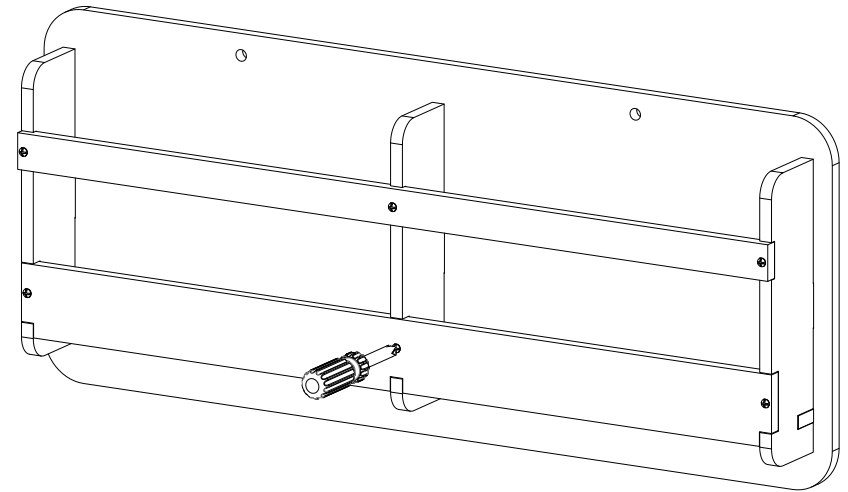

# Board list

39-2pcs	40-1pcs	
41-1pcs	30-1pcs	31-1pcs
32-1pcs	33-1pcs	

**A total of 8 pcs**

Step 1: Use hardware E, G, L to connect #8 and #39 together. Get 8 # components

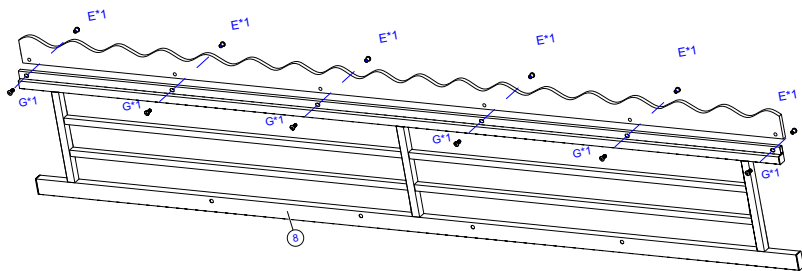

8-1pcs	39-1pcs	M6*15-6pcs	ΦM6*10-6pcs	

Step 2: Use hardware A, T, Q, Y to connect #2 #3 #11 and #8 components together.

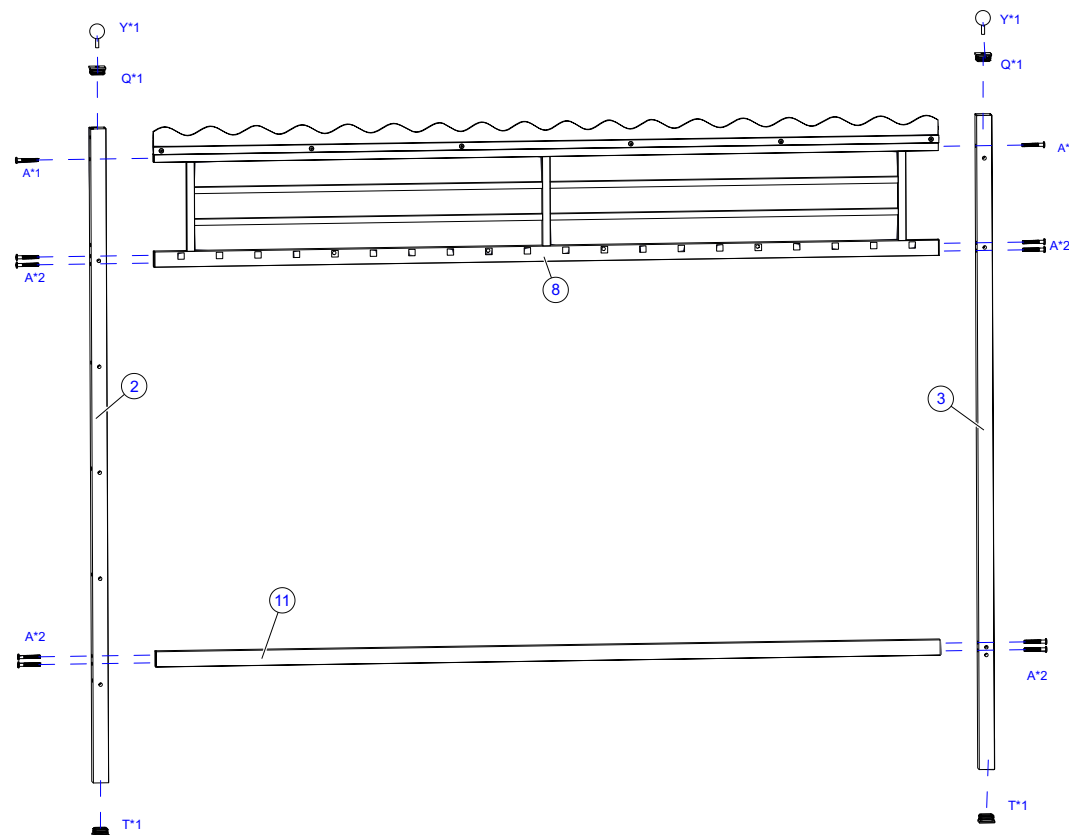

2-1 pcs	3-1 pcs	1 pcs 8 # components	40*40F-2pcs	20*40-2pcs
		11-1pcs	40*40FQ-2pcs	M8*55-10pcs

Step 3: Use hardware E, G, L to connect #10 #34 and #39 together.

Get #10 components

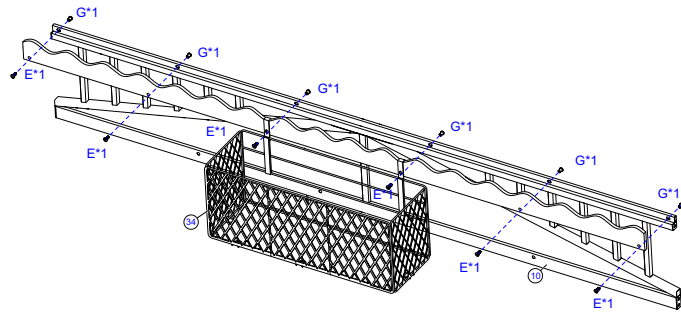

 10-1pcs	 79.4*2.76 " 2018*70mm 39-1pcs	 34-1pcs	 E M6*15-6pcs	 G ΦM6*10-6pcs
-------------	---	-------------	---------------------	----------------------

Step 4: Use hardware A, L, T, Q, Y to connect #1 #4 and #10 components together.

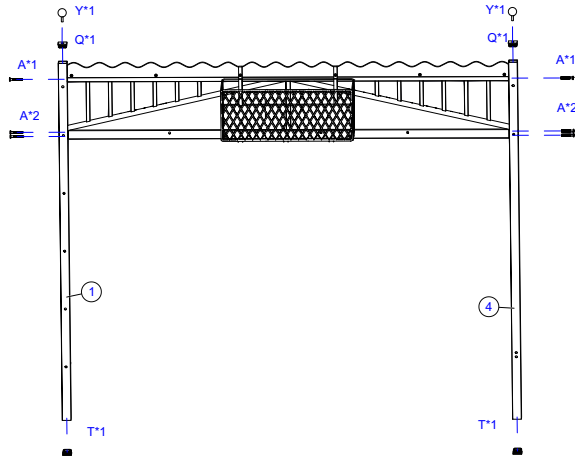

 1-1 pcs	 1 pcs #10 components	 Q 40*40FQ-2pcs	 A M8*55-6pcs
 4-1 pcs	 T 40*40F-2pcs	 Y 20*40-2pcs	 L

Step 5: Use hardware E, G, W, M, Y to connect #5 #41 together.

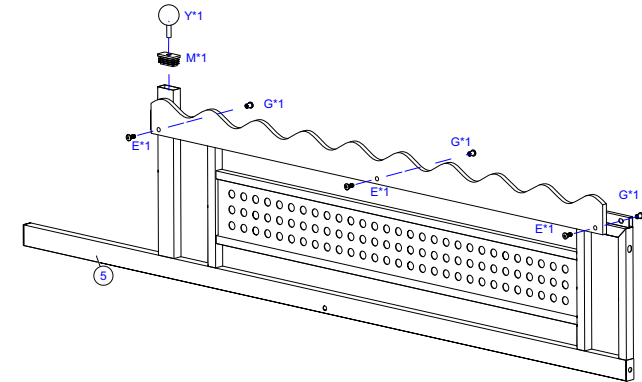

 5-1pcs	 23.5*2.76 " 598*70mm 41-1 pcs	 M 20*40-1 pcs	 Y 40*40-1pcs	 E M6*15-3pcs	 G ΦM6*10-3pcs
------------	---	----------------------	---------------------	---------------------	----------------------

Step 6: Use hardware E, G, W to connect #9 #40 together.

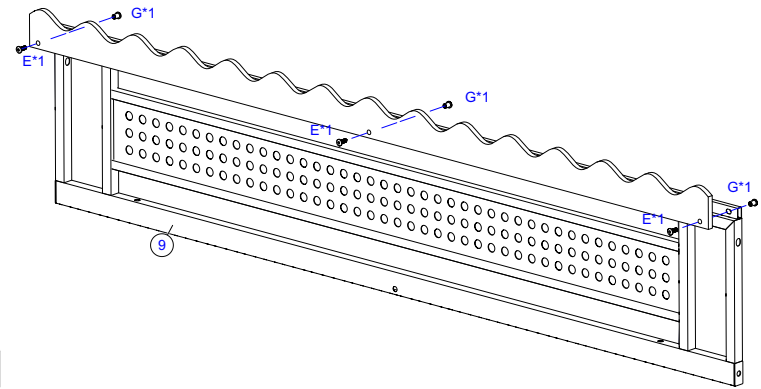

 9-1pcs	 38.5*2.76 " 978*70mm 40-1pcs	 E M6*15-3pcs	 G ΦM6*10-3pcs
------------	--	---------------------	----------------------

Step 7: Use hardware A, L to connect #12 #14 together.

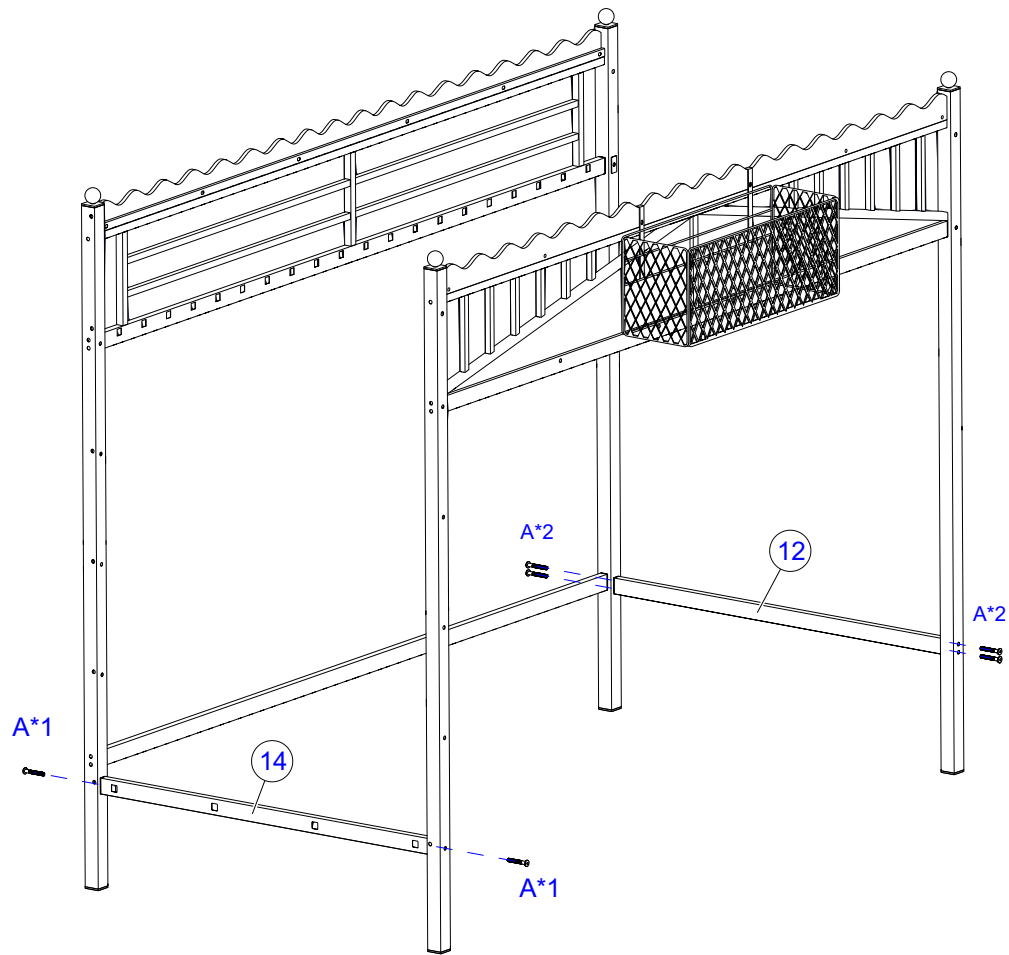

<p>12-1pcs</p>	<p>14-1pcs</p>	<p>A M8*55-6pcs</p>	<p>L</p>
----------------	----------------	-------------------------	----------

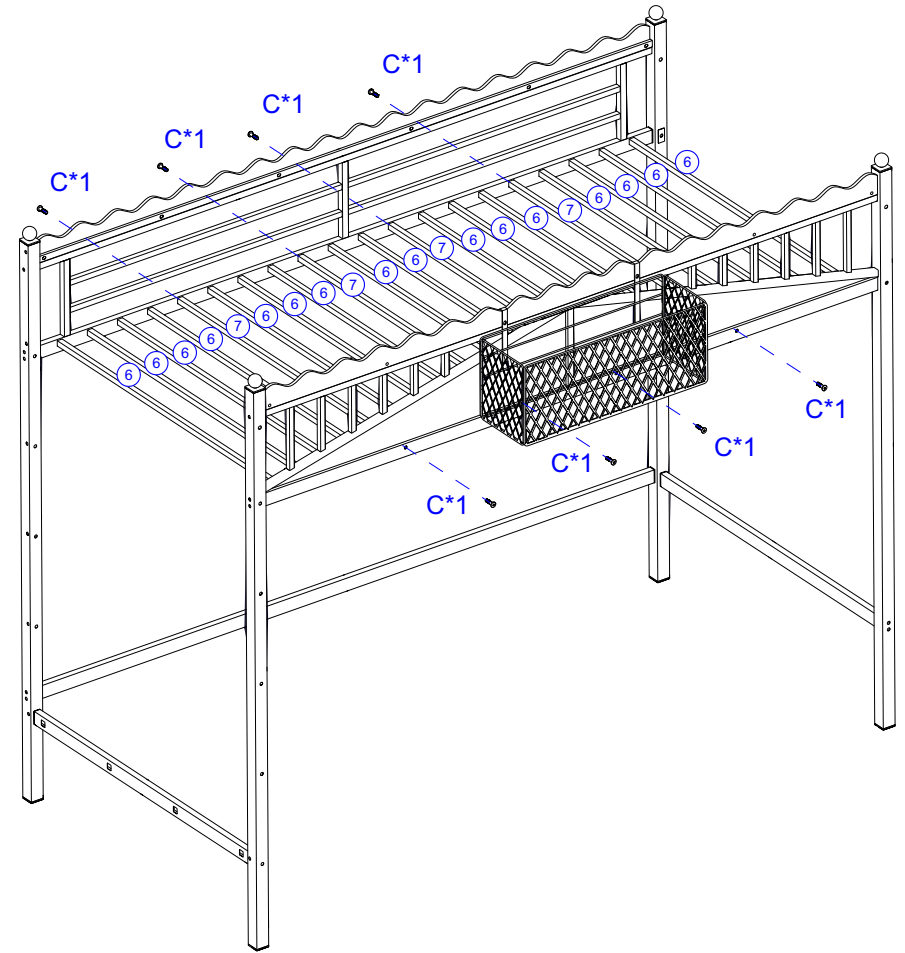

Step 8: Use #6 and #7 to insert into the corresponding square hole of #8 #10 and use hardware C, L to connect #7, #8, #10 together.



<p>6-16pcs</p>	<p>7-4pcs</p>	<p>C M8*30-8 pcs</p>	<p>L</p>
----------------	---------------	--------------------------	----------

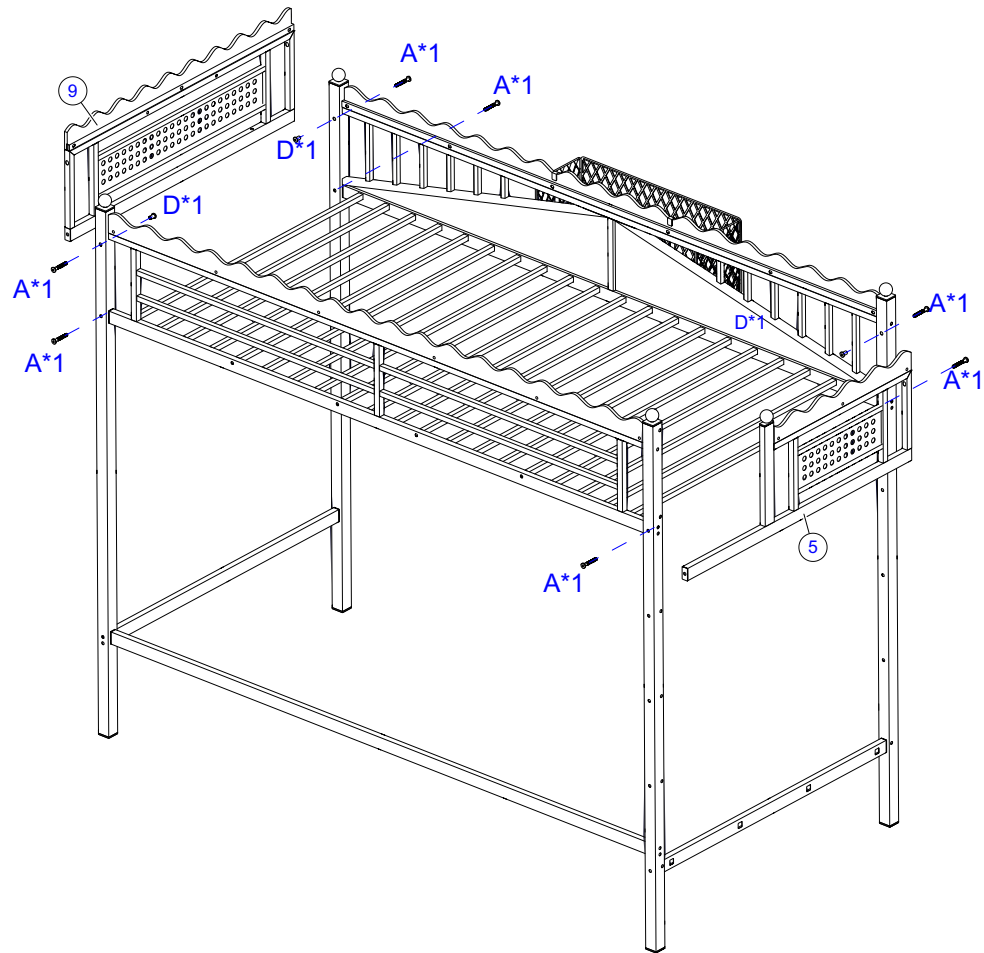

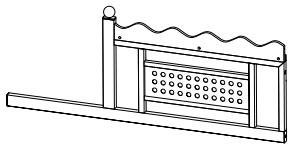
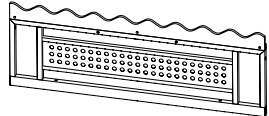
Step 9: Use hardware A, D L to connect #5, #9 together.



			
5-1pcs	9-1pcs	M8*55-7pcs	ΦM8*16-3pcs

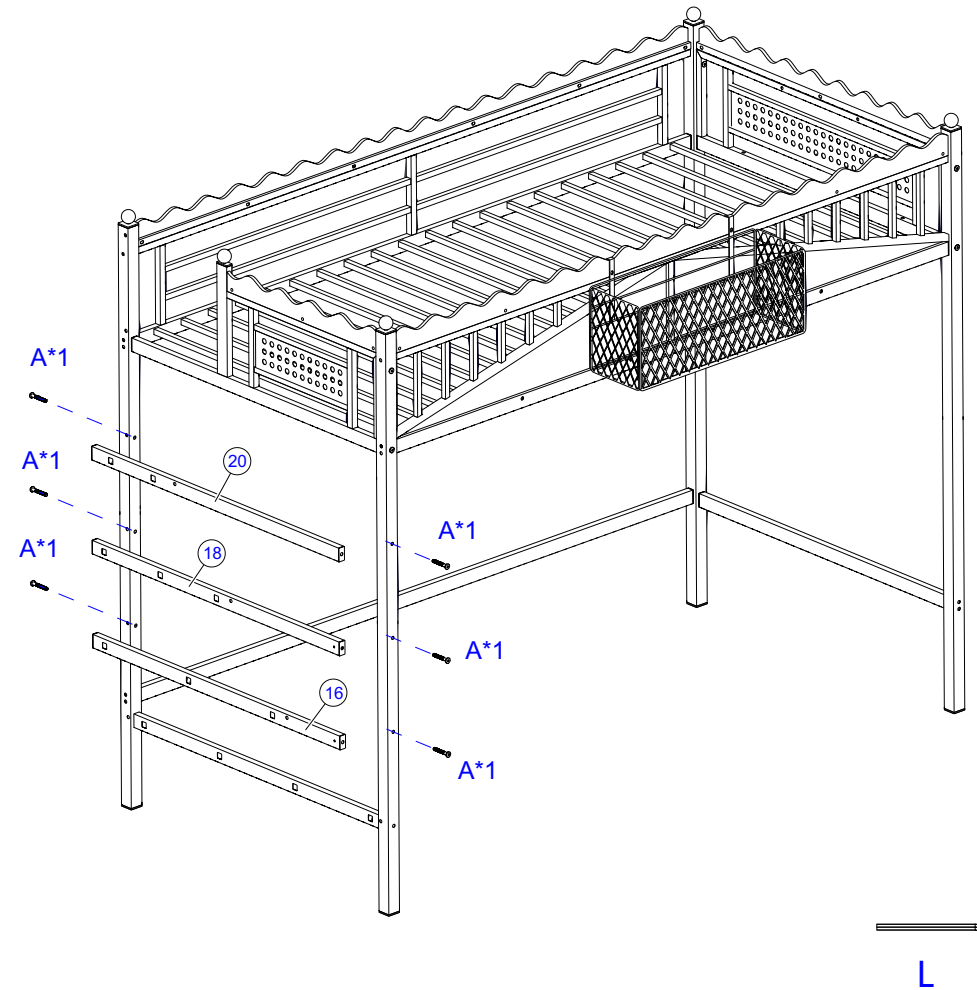

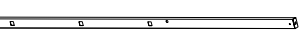



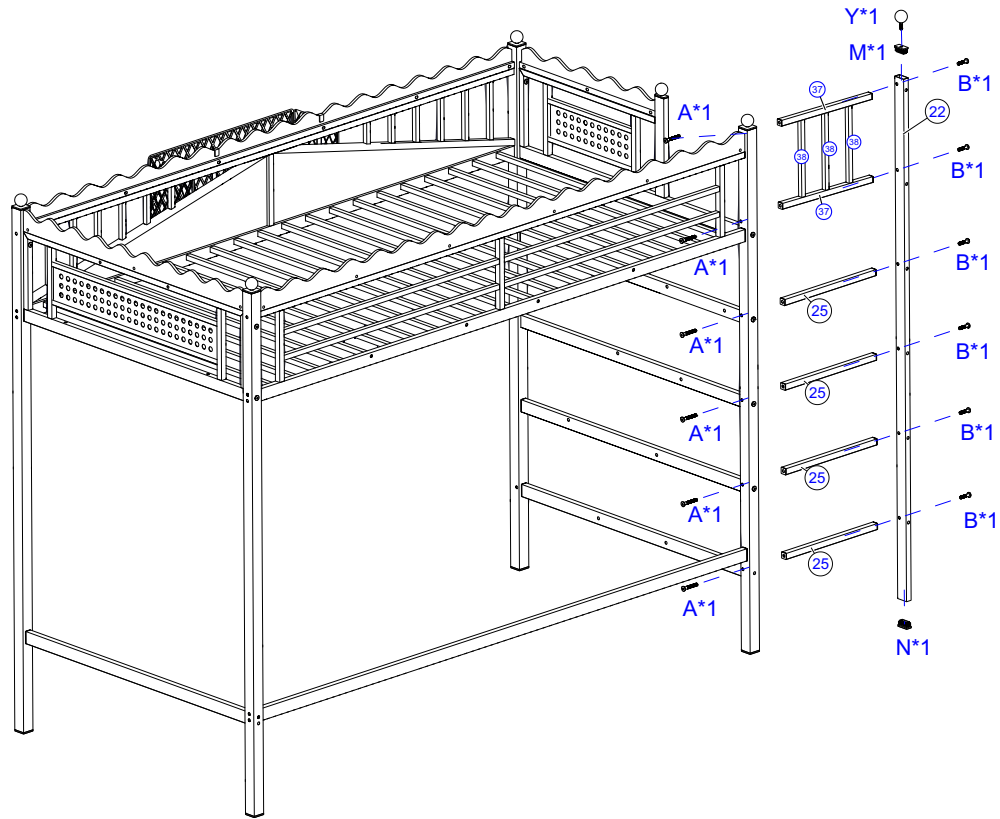

Step 10: Use hardware A, L to connect #16, #18, #20 together.

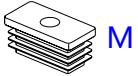

			
16-1pcs	18-1pcs	20-1pcs	M8*55-6pcs

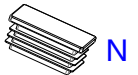

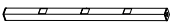

Step 11: Use hardware A, B, L to connect #22, #25, #37, #38 together.

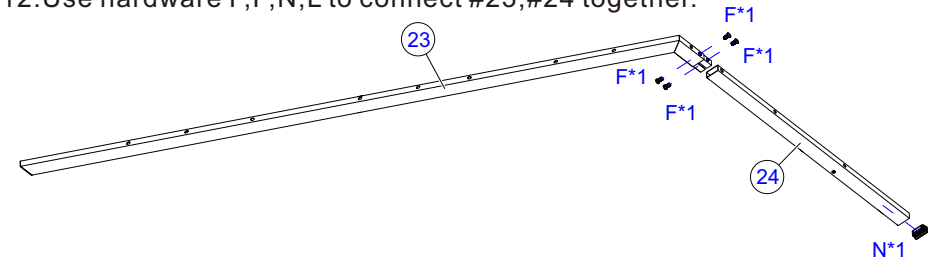

 22-1 pcs	 20*40-1 pcs	 M8*55-6 pcs	 M8*35-6 pcs
 25- 4 pcs	 20*40-1 pcs	 20*40-1 pcs	 37-2 pcs
			 38-3 pcs

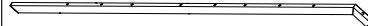

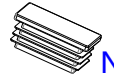



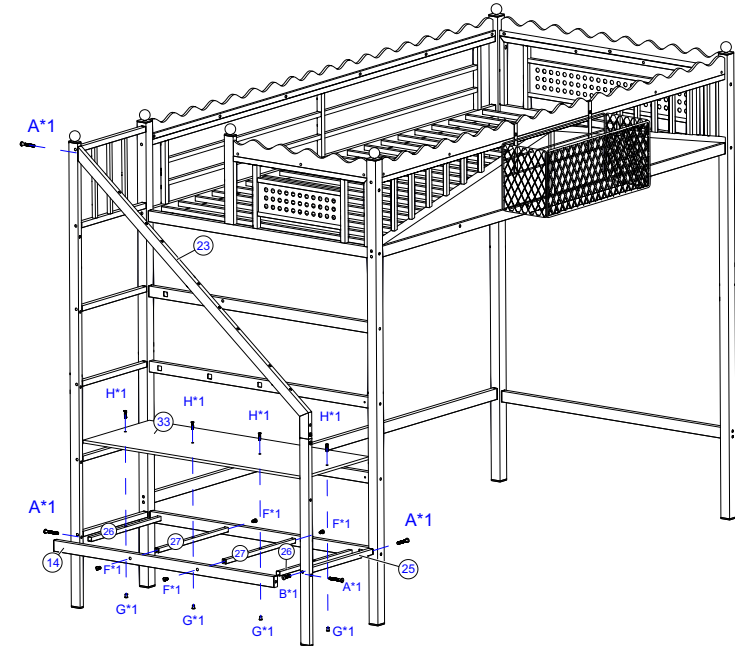

Step 12: Use hardware F, P, N, L to connect #23, #24 together.

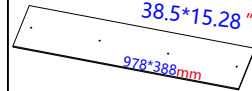

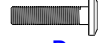
 23-1 pcs	 24-1 pcs	 18*60 -2 pcs	 20*40-1 pcs	 M8*15-4 pcs
---	---	---	--	--



Step 13: Use hardware A, B, F, H, G to connect #14, #25, #26, #27, #33 together.



 33-1 pcs	 26- 2 pcs	 14-1 pcs	 M8*35-1 pcs	 M8*15-4 pcs
 25- 1 pcs	 27- 2 pcs	 M8*55-4 pcs	 M6*20-4 pcs	 ΦM6*10-4 pcs

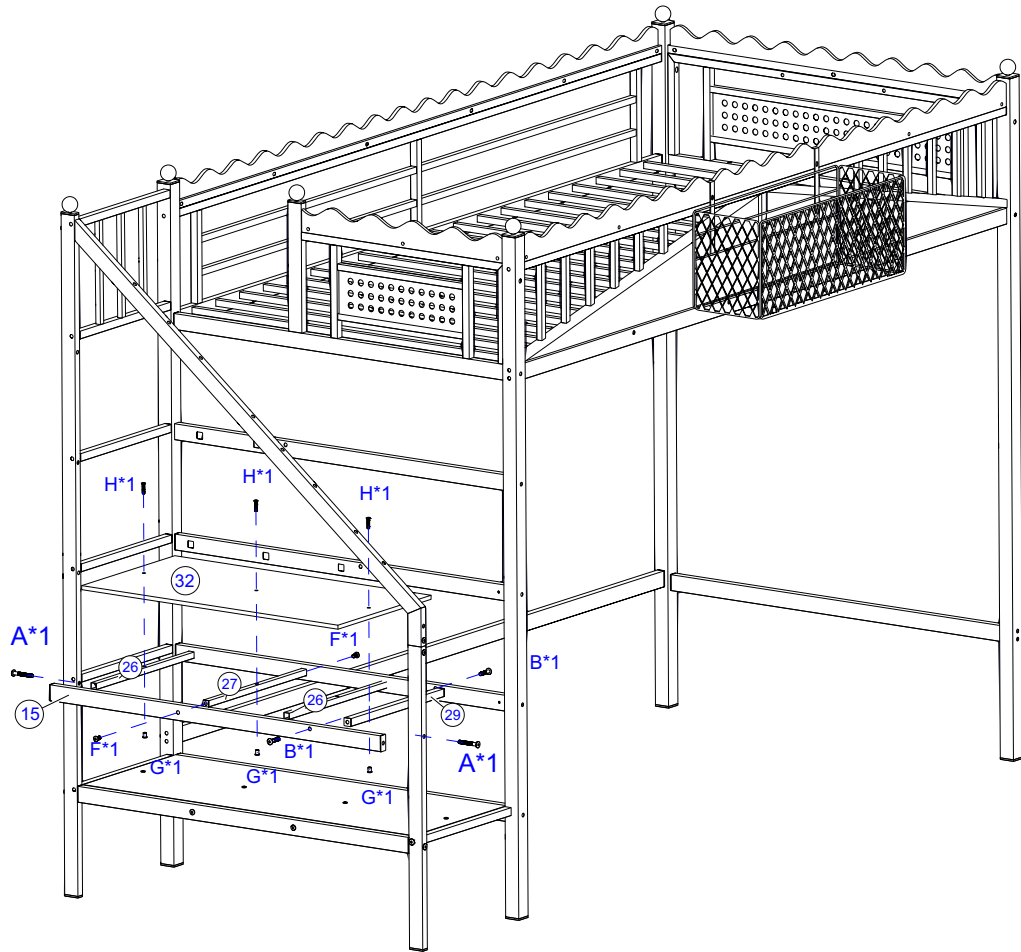

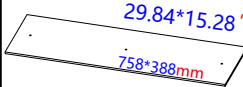

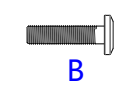
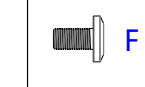
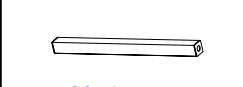
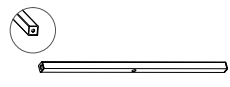
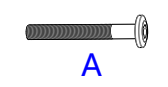
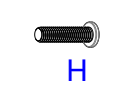
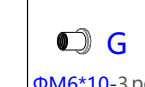

Step 14: Use hardware A,B,F,H,G to connect #15,#26,#27,#29 #32 together.

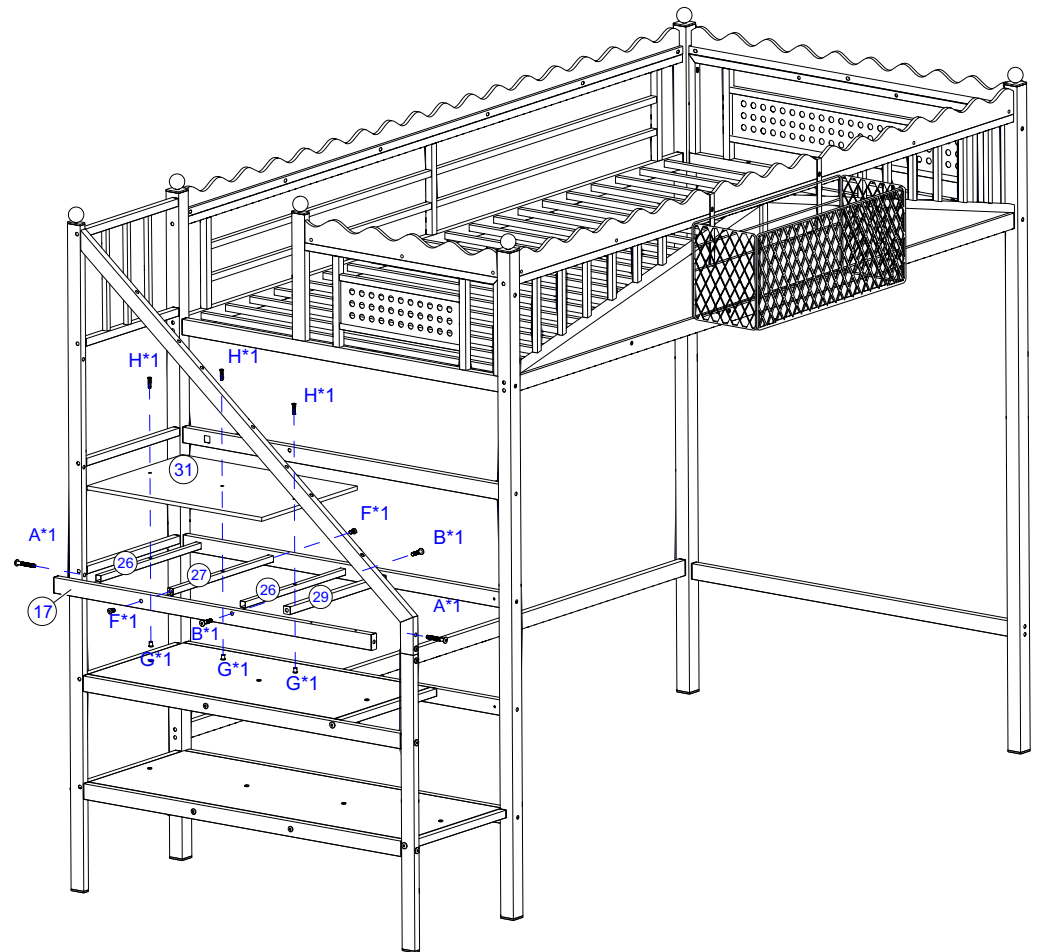

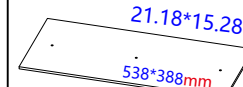
 32-1 pcs	 26- 2pcs	 15-1 pcs	 B M8*35-2 pcs	 F M8*15-2 pcs
 29- 1pcs	 27- 1pcs	 A M8*55-2 pcs	 H M6*20-3 pcs	 G ΦM6*10-3 pcs



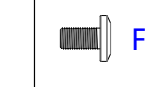

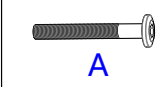
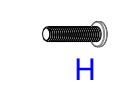
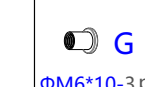

Step 15: Use hardware A,B,F,H,G to connect #17,#26,#27,#29 #31 together.

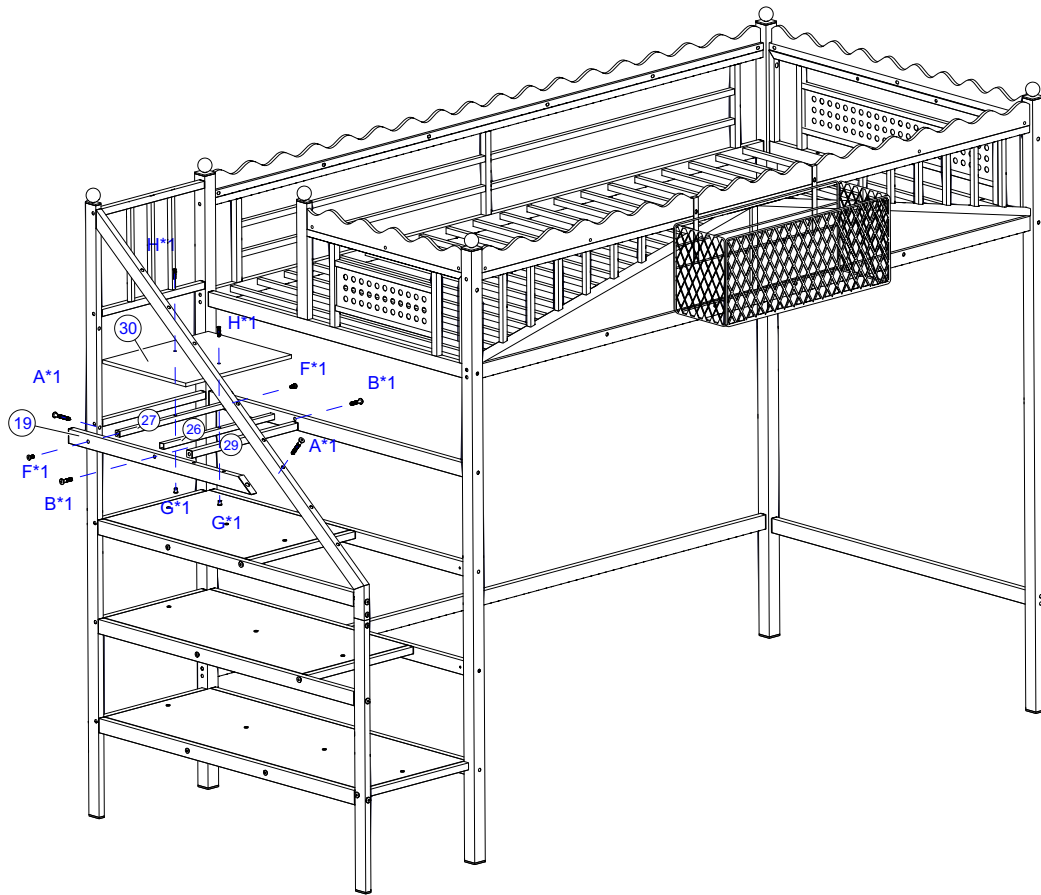

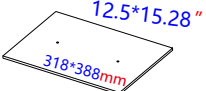
 31-1 pcs	 26- 2pcs	 17-1 pcs	 B M8*35-2 pcs	 F M8*15-2 pcs
 29- 1pcs	 27- 1pcs	 A M8*55-2 pcs	 H M6*20-3 pcs	 G ΦM6*10-3 pcs

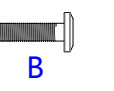

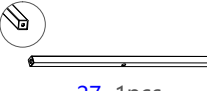
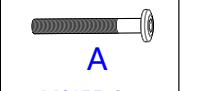
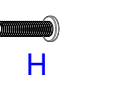
Step 16: Use hardware A,B,F,H,G to connect #19,#26,#27,#29,#30 together.



 30-1 pcs	 26- 1pcs	 19-1 pcs	 B M8*35-2pcs	 F M8*15-2pcs
 29- 1pcs	 27- 1pcs	 A M8*55-2pcs	 H M6*20-2 pcs	 G ΦM6*10-2 pcs

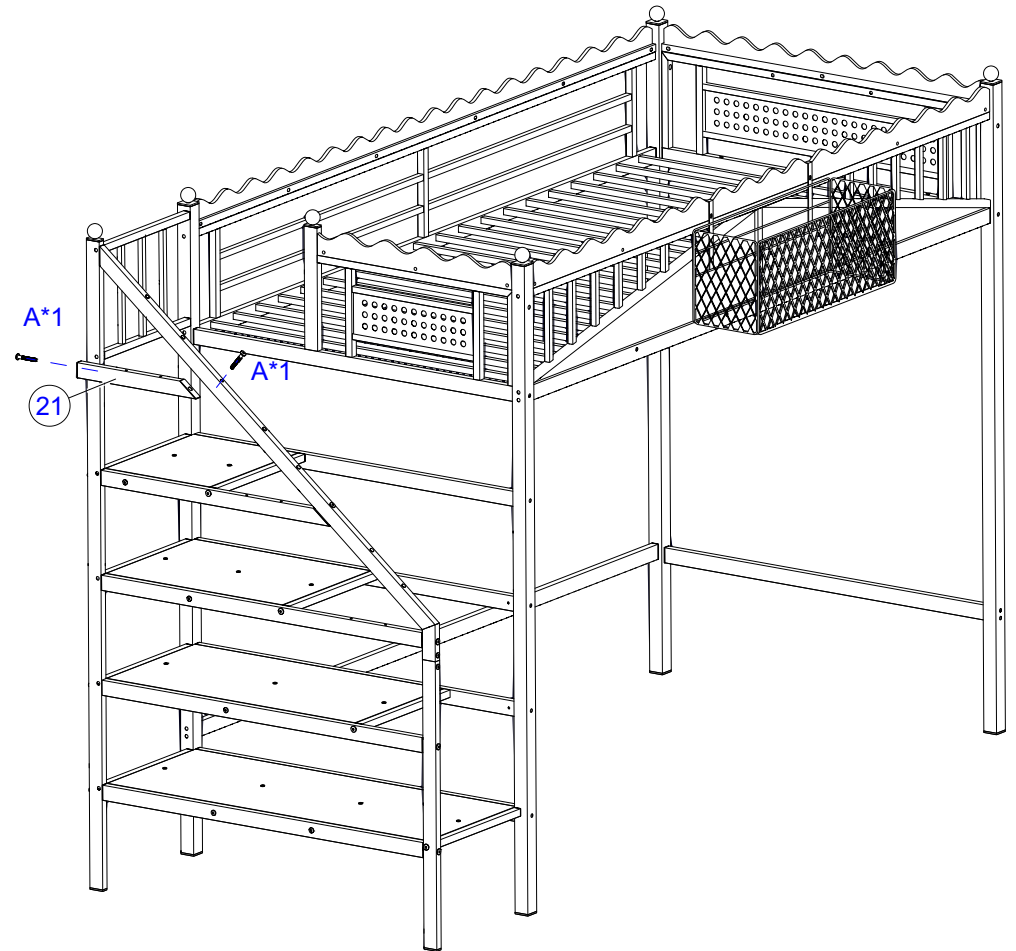

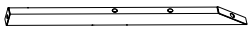

Step 17: Use hardware A,L, to connect #21 together.

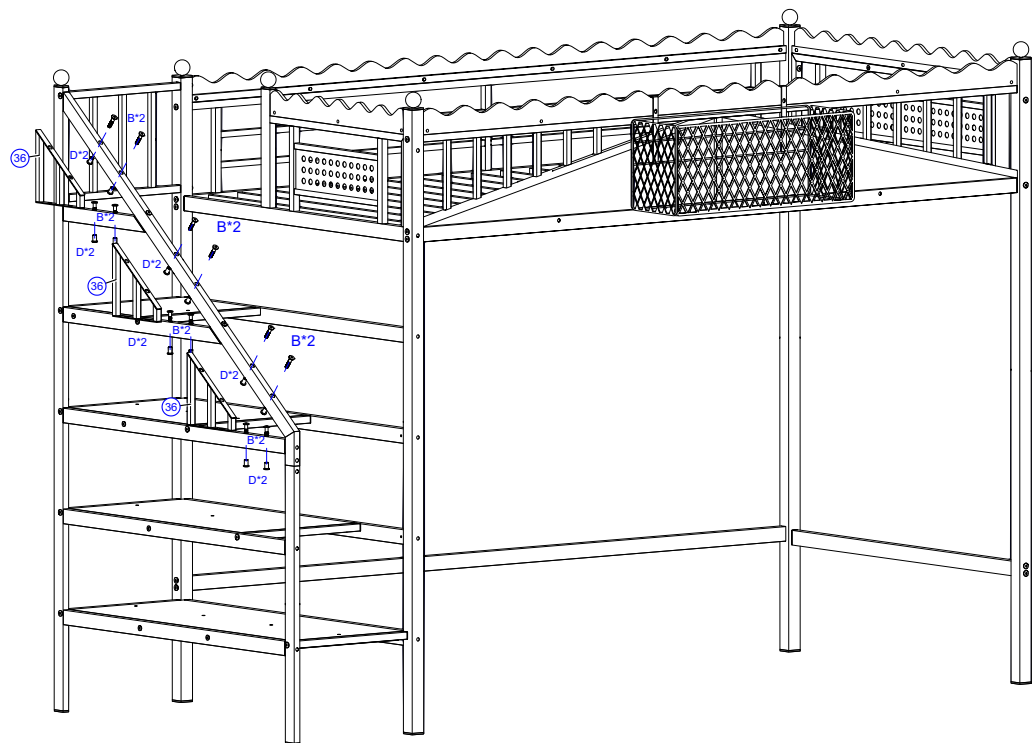

 21-1pcs	 A M8*55-2pcs	 L	
--	--	--	--

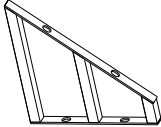



Step 18: Use hardware B,D,L to connect #36 together.

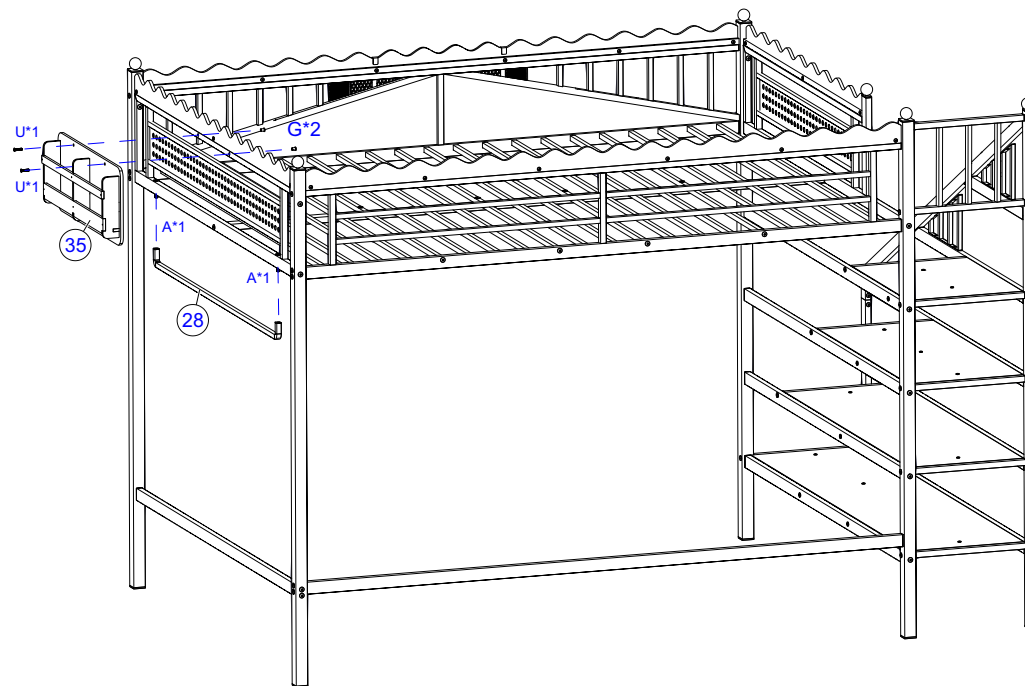

 <p>36-3pcs</p>	 <p><b>B</b> M8*35-12pcs</p>	 <p><b>D</b> ΦM8*16-12 pcs</p>	 <p><b>L</b></p>
--	---	---	--

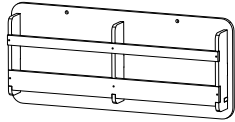
Step 19: Use hardware A,U,G to connect #28,#35 together.



 <p>35-1pcs</p>	 <p>28-1pcs</p>	 <p><b>A</b> M8*55-2 pcs</p>	 <p><b>G</b> ΦM6*10-2pcs</p>	 <p><b>U</b> M6*25-2pcs</p>
--	--	---	---	--

# Completed attic bed

Fix the wall, prevent movement,  
selective installation

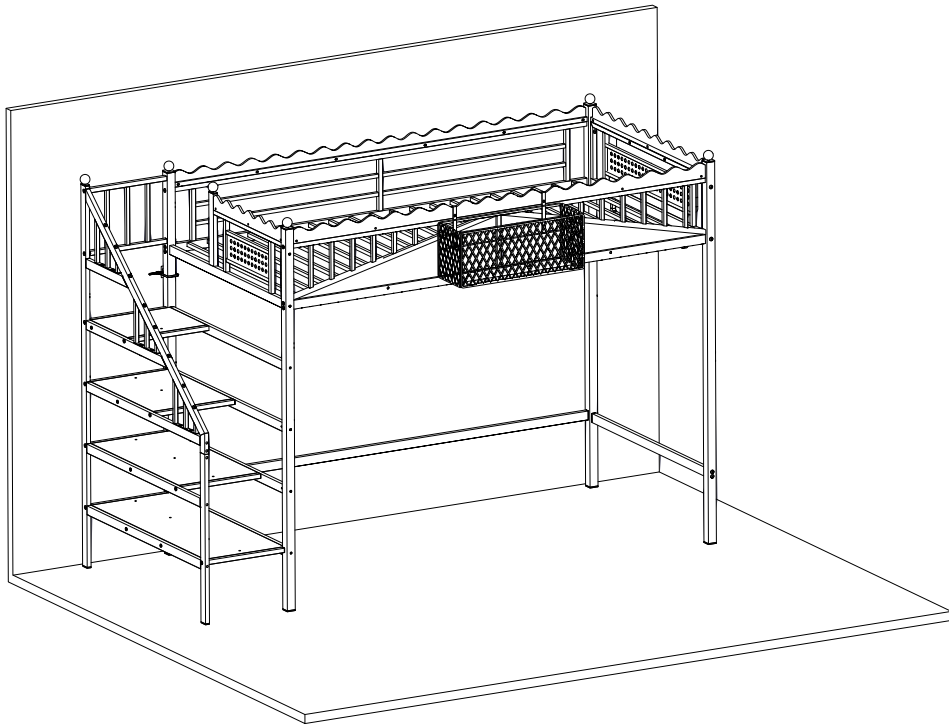
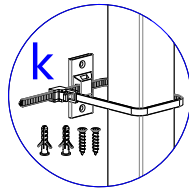

Note: Tighten all the steps before use,  
thank you.

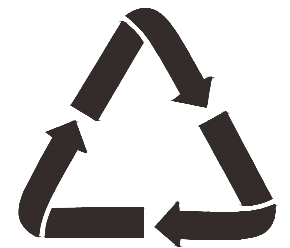

Recyclable garbage