

SALAV®



USER MANUAL

Please read all instructions
carefully before using
this product.

RETRO EDITION
DUOPRESS STEAMER & IRON
MODEL: IS-900



www.salavusa.com

Dear Valued Customer

Thank you for purchasing this SALAV product. Please read this manual prior to using your SALAV appliance. For more product information, FAQ and customer support please visit our website at www.salavusa.com.

Important Safety Instruction :

1. Prior to first use, inspect all parts of the steamer to make sure all parts are intact. The steamer must not be used if it has been dropped, if there are visible signs of damage to the body or cord or if it is leaking.
2. DANGER - any appliance is electrically live even when the switch is off.
3. To reduce the risk of death by electric shock always unplug this steamer from the electrical outlet immediately after using and before cleaning.
4. Do not reach for an appliance that has fallen in to water. Unplug it immediately.
5. Do not immerse or let appliance be soaked in water. Do not use while bathing or in the shower.
6. This appliance is not a toy and should not be used by children. Close supervision is necessary when this appliance is used near children, or individuals with certain disabilities. Unsupervised use could result in fire or personal injury.
7. Never pull on the cord to disconnect from the electrical outlet; grasp plug and pull to disconnect.
8. To reduce the risk of electric shock, do not disassemble or attempt to repair the appliance; contact our customer support listed at the end of this manual
9. To reduce the likelihood of circuit overload, do not operate another high wattage appliance on the same circuit.
10. Use this appliance only for its intended use. Do not use attachments not specified in this manual.
11. If an extension cord is absolutely necessary, a cord with a 15 ampere rating should be used. A cord rated for less amperage can result in a risk of fire or electric shock due to overheating. Care should be taken to arrange the cord so that the cord cannot be pulled or tripped over.
12. Burns can occur from touching steam output vents, hot water, or steam. Do not hold your hand in front of steam.
13. Do not direct steam at people, animals, plants or clothes while they are being worn.
14. While steam is being emitted, this appliance may cause burns if it is used too close to the skin, scalp or eyes, or if it is used incorrectly. To reduce the risk of contact with hot water emitting from steam vents, test appliance before each use by holding it away from body.
15. Ensure the steamer is properly assembled before use.
16. Do not place the appliance in the same spot for more than 10 seconds to avoid damage from heavy heating.
17. Do not touch the bottom of the appliance during operation.
18. Do not tilt or turn the appliance over when in use.
19. Do not fill the water tank with hot water or corrosive cleaning agents. Distilled water is strongly recommended.
20. Fill water into the water tank by removing the water tank cover using the measuring cup (90 ml). Do not overfill!
21. Unplug the product when filling with water, whenever the water tank is empty, and when not in use. Wait until product is completely cooled down before storing.
22. Make sure the product and its protective mat are placed on a level surface to prevent the product from falling. Always place product on the protective mat after using until completely cooled down.

PRODUCT COMPONENTS

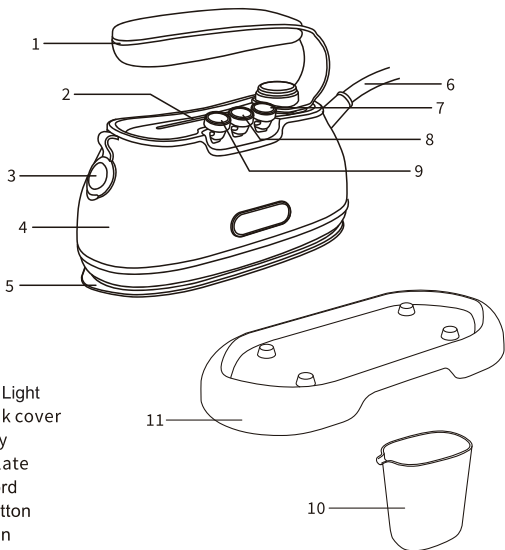

1. Handle
2. Indicator Light
3. Water tank cover
4. Main body
5. Ironing plate
6. Power Cord
7. Power Button
8. Iron Button
9. Steam Button
10. Measuring Cup
11. Heat-Resistant Holder

Product specification

Input Voltage: 120V ~ 60Hz

Output Power: 1000W

Water Tank Capacity: 90 mL

Steam preheating time: 40s

INSTRUCTIONS FOR USE

1. Before using, if needed, turn the handle 180° counter clockwise for a more ergonomic grip. A "CLICK" sound indicates the handle is now secure in its new position.

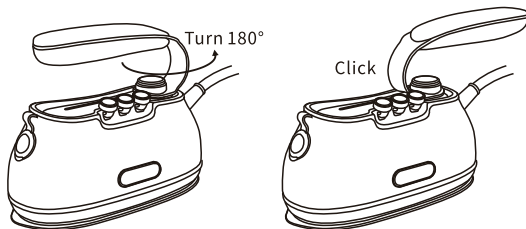

Attention

**Turn handle gently.
Handle is not made to turn more than 180° counter clockwise.**

2. Open the water tank cover. Use the measuring cup to fill water into the water tank and securely close the cover.

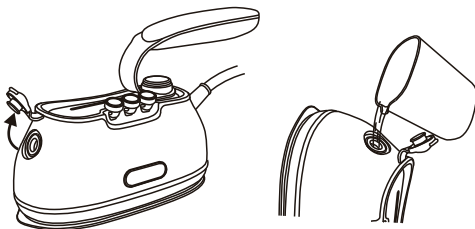

INSTRUCTIONS FOR USE

3. Plug the unit into the power outlet. Press the Power Button. The indicator light will appear as a solid red light indicating the unit is on.
- Press the Iron Button once and wait 50 seconds to begin ironing. Iron Mode is shown by the blue indicator light. Once the blue indicator light stops flashing and turns solid blue, the iron is now ready to use.
 - Press the Steam Button once and wait 10 seconds to begin steaming. Steam Mode is shown by the orange indicator light.
 - Press the Iron Button once to return to Iron Mode.
 - Press the Steam Button once to return to Steam Mode.
 - Press the Power Button once in either Iron or Steam mode to fully turn off the unit.

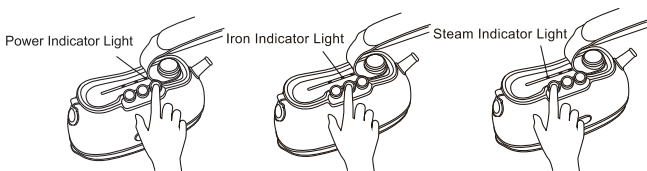

Attention

Once preheating is completed, the two modes of Iron and Steam can be switched freely back and forth by clicking each respective button. If the unit is shut off and turned back on within 30 seconds, there is no need to wait for preheating and the unit can enter Iron or Steam Mode immediately. If the unit is shut off for more than 30 seconds, the unit will need to preheat again before being able to use the Iron and Steam Modes.

INSTRUCTIONS FOR USE



Do not touch the ironing plate once the unit is plugged in.

Do not overfill the water tank with water. Wipe clean any spills with a dry cloth.

Do not fill the unit with water when plugged in.

Use distilled water in this unit to prevent damage and extend the life of this product.

4. After using, place the unit back onto its heat-resistant holder. Once the unit has cooled down completely, turn the handle clockwise until a "CLICK" sound is heard, indicating the handle has locked into place before storing.

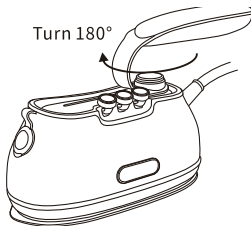
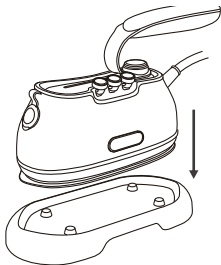

IRONING GUIDELINE

1. The ironing panel can reach a high temperature of up to 200°F. Do not leave the unit ironing or steaming in one spot for a long time.
2. Before putting the steamer away for storage, continue to steam until no steam is spraying out of the panel. Be sure the steamer is completely cooled down and turned off before storing (approximately 30 mins).

TROUBLE SHOOTING

PROBLEM	REASON	SOLUTION
Unit fails to iron/steam. Indicator light does not illuminate.	The appliance is not plugged in	Connect the plug to the power supply
	The household power fuse is off or fused	Check the power supply or ask qualified electricians for help
Unit fails to iron/steam. Indicator light illuminates.	There is no water in the tank	Add water to the max line
	Temperature controller is not working	Add water to cool the temperature controller down before steaming again
	Unit is scaled and needs to be decalcified	Add a descaling solution of 1/2 distilled water and 1/2 distilled vinegar to the water tank and turn on the steamer until the solution is empty. Refill the tank with distilled or filtered water and allow it to steam through the unit fully before steaming garments.
Ironing plate produces heat and steam, but the indicator light is off.	Damaged indicator light.	Contact customer support.
Water ejects from ironing plate.	Boiler does not work.	Contact customer support.

CLEANING AND MAINTENANCE

1. If the appliance shows visible damage or if the power cord is damaged, please contact customer service for help and maintenance. Do not try to disassemble or repair.
2. Please pull out the plug and wait until the appliance is completely dry and cooled down before cleaning and/or storing.
3. Do not place the appliance in water, Use a cloth to clean the steamer and steam plate.

Warranty exclusions and limitations

This Limited Product Warranty applies only to the original purchaser of the SALAV branded product that was purchased from SALAV directly or SALAV's authorized reseller. Without limiting the foregoing, the Limited Product Warranty does not apply to any (a) SALAV products and services other than the Brand New SALAV branded products which are purchased directly from SALAV or from SALAV's authorized reseller, (b) non-SALAV products, even if included or sold with a Product, including, without limitation, any counterfeit products, (c) products that are, or SALAV reasonably believes to be, stolen, (d) consumables (such as cleaning pads). This Limited Product Warranty does not apply to third party products or accessories, including but not limited to products with the "Made for SALAV" or "Works with SALAV" logos or advertising.

This Limited Product Warranty does not apply to a product or part of a product that has been replaced, repaired, serviced, altered, refurbished or modified by anyone who is not authorized by SALAV, nor does it apply to any cosmetic damage such as scratches and dents. In addition, this Limited Product Warranty does not apply to damage or defects caused by (a) use with non-SALAV products such as non-SALAV steamer liquid; (b) accident, abuse, misuse, mishandling, flood, fire, earthquake or other external causes; (c) normal wear and tear or aging of the product such as discoloration of product; or (d) operating the product (i) outside the permitted or intended uses described by SALAV under SALAV's Product User Manual, (ii) not in accordance with instructions provided by SALAV, or (iii) with improper voltage or power supply, water or other add-on products.

No SALAV, authorized reseller, distributor, agent, reseller, or employee is authorized to make any modification, extension or addition to this Limited Product Warranty. If any term contained herein is held to be illegal, void or unenforceable, the legality or enforceability of the remaining terms shall not be affected or impaired.

If you have any questions regarding this warranty, you may contact us through our website:
www.salavusa.com

Limitation of Damages

Except to the extent prohibited by applicable law, SALAV shall not be liable for any incidental, indirect, special or consequential damages, including, without limitation, loss of profits, revenue, resulting from any breach of express or implied warranty or condition or under any other legal theory, even if SALAV has been advised of the possibility of such damages. SALAV warranty and liability is only limited to replacement of the defective item.

Register your product today!

Registering is quick, easy and offers you benefits over the lifetime of your product. You'll receive:

Product Support Reminders and Alerts

We'll contact you with any important product maintenance reminders and alerts.

Faster Service

Supplying your information now saves your time should you need to contact us with questions regarding your product.

Special Promotions

Optional: Register your email to receive notice of offers, contests, cleaning tips and more!

Visit www.salavusa.com/pages/product-registration-1

For information about replacement parts, or questions about your warranty:

Call:

Salav customer care
1(855) 725-2887

Email:

support@ctbrandco.com

NOTE: Please keep your original sales receipt. It provides proof of purchase date in the event of a warranty claim.

Follow us on social media

Explore more videos



SALAVNorthAmerica



salavusa



salavusa



salavusa

