

Flex Apex Assembly 4ft Kit

Page 1 of 2

1.a Unpack all of the components and check that you have all of the parts required. Please use the check list on this page.

1.b Carefully remove the untreated timber that makes up the pallet your building was delivered on and discard this.

1.c The underside of the floor must be treated with a quality wood preserver.

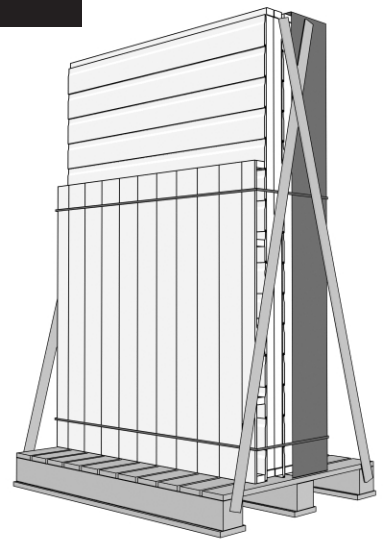

1. Pre Assembly

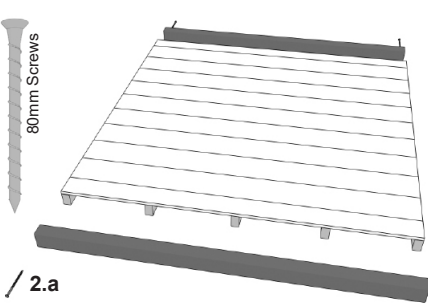

2.a

2.a Lay down the floor and place the heavy duty bearers running parallel with the floor boards and flush with the floor. Screw them in place with the 80mm screws .

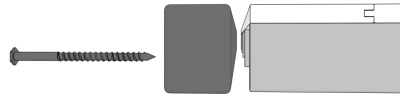

2.b Lay out the completed floor in the desired location and think about where you want to position the walls. The gables of the building will sit on top and in line with the heavy duty bearers.

2.c Place a side panel at a right angle to the panel positioned on the gable end. Secure the panels together from the inside, using the 50mm screws provided.

2.d Place the next side wall in position and secure this to one of the other side panels, again using the 50mm screws provided.

2. Floor and Walls

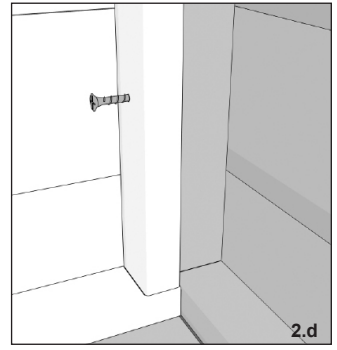

2.d

Note: See back for sizes greater than 4x4

Important:
The floor panel must be laid on a firm and level base.



3. Walls

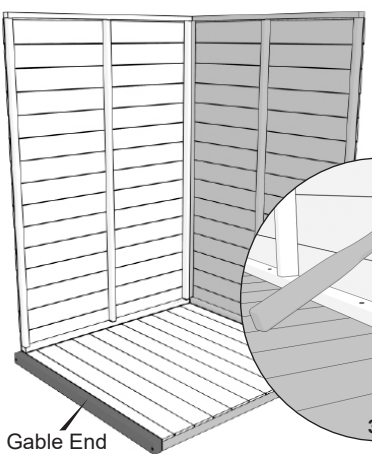

Gable End



3.a When you have secured all of the wall panels to each other. Attach them to the floor using the 65mm nails.

3.b Ensure that the nails are driven through the side/gable base rails, through the floor boards and in a position where they will finally penetrate the floor joist.

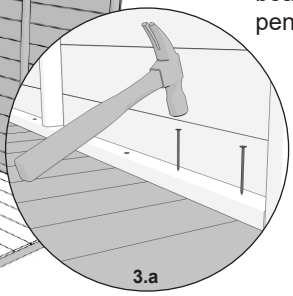

3.a

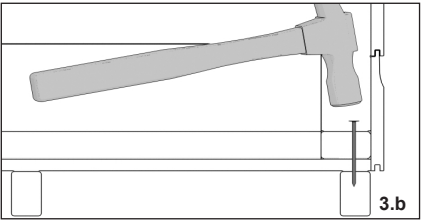

3.b

4. Hanging the Door

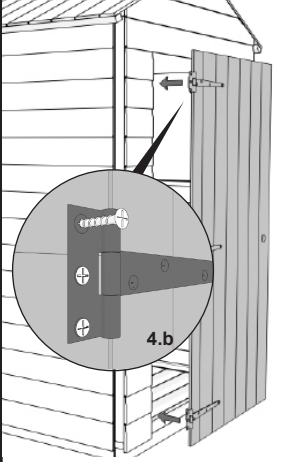

4.b

Important: The door has been manufactured so it can be left or right hand hinged to suit your needs.

4.a Choose whether you want your door to be right or left hand hinged and line it up in the framing accordingly.

4.b Secure the hinges in place using the 25mm black hinge screws provided. Make sure it is level or your door will stick/not close properly.

4.c Fix the turn button in place. Chose a place close to the top of the door. Don't screw in too tightly or it won't turn.

4.d Line up the lock with the pre-drilled hole in the door and fix this in place with the screws. Make sure the lock is on the inside of the shed when you close the door.

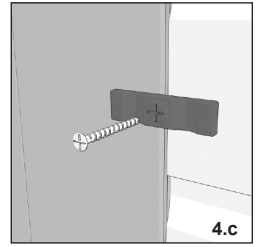
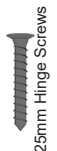

4.c

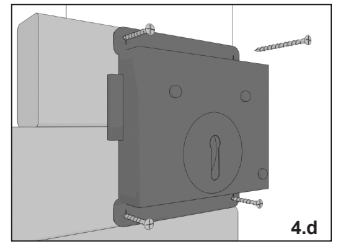

4.d

5. Gable Tops **Note:** See back for sizes greater than 4x4

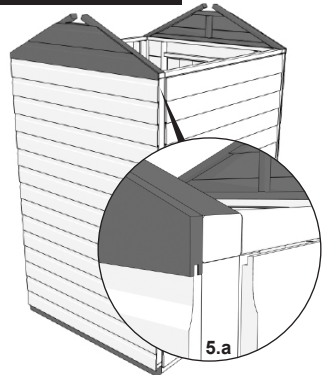

5.a

5.a Line up the gable tops with the panel, remembering to place them above the heavy duty bearers.

5.b Secure with 50mm screws from the inside, screwing upwards into the framing.

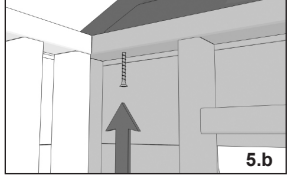
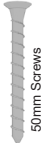

5.b

6. Roof Panels **Note:** See back for sizes greater than 4x4

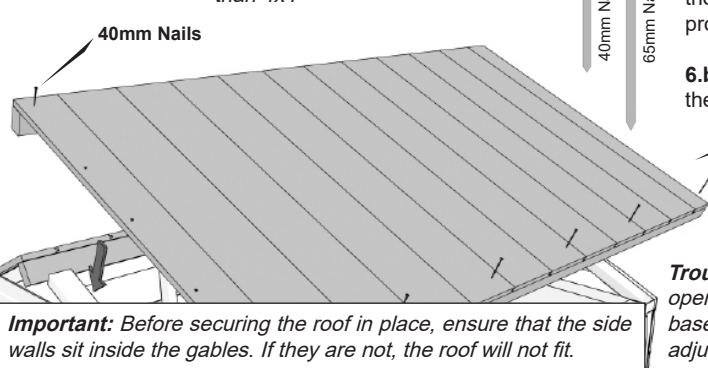

Important: Before securing the roof in place, ensure that the side walls sit inside the gables. If they are not, the roof will not fit.



65mm Nails

6.a Place roof panels in position and secure these internally to each other with the 65mm nails provided.

6.b Nail the roof to the gable and side frame with the 40mm and 65mm nails provided.

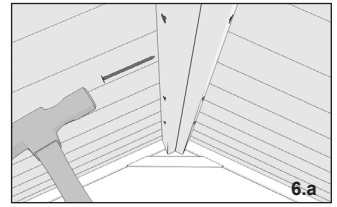
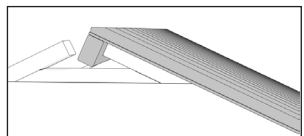

6.a

Troubleshoot: If at this point the roof panels do not align correctly, the door does not open/close properly or the building looks twisted at all, then it would suggest that the base is not correctly level. Therefore, one or more corners of the building may need adjusting so the base is square/level.

Important: Ensure the overhang of the roof is equal at each gable end.

7. Roof Felt
Page 2 of 2

7.a Roll out the mineral roofing felt along the lower part of one side of the roof. Allow sufficient overhang to fold down onto the roof framing (but not the underside of the roof).

7.b Use clout nails to tack along top edge of felt in to framing. Repeat this process on the other side of the roof.

7.c Fold the overhanging felt at the gable ends under the roof boards and tack in place, you could cut the felt at the corners to make it fit if you wish.

7.d As these sheds are only 4ft wide, there will be adequate felt to cover the ridge, by folding the pieces over the ridgeline. You must make sure you don't set the pieces too low so that you have enough to do this.

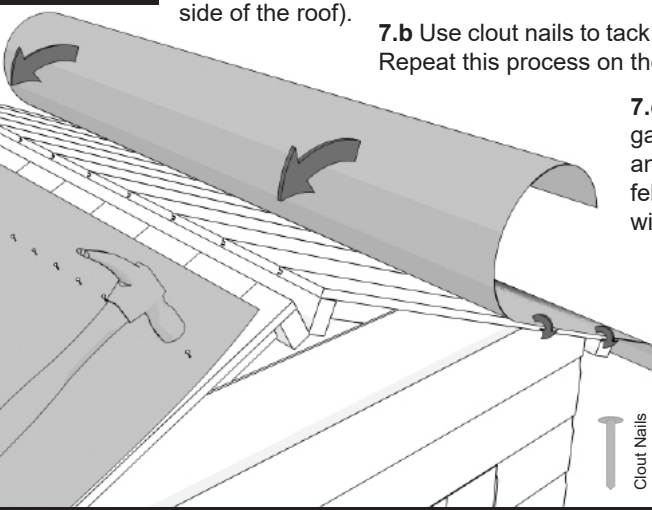

Clout Nails

8. Bargeboards and Finials

8.a Fit the bargeboards to the roof panels, trapping the overhanging end of the felt in between to provide a weatherproof seal.

8.b Secure the diamond finials over the top of the bargeboards.

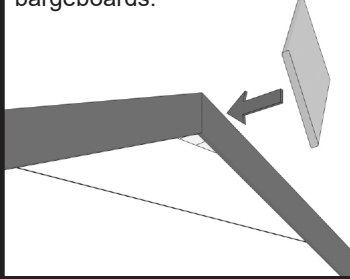

40mm Nails

9. Windows

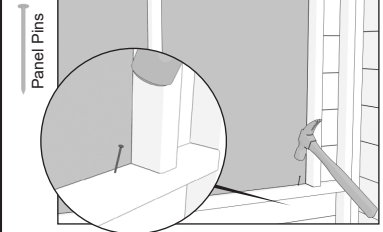

9.a Glaze the windows by securing the glass or perspex from the inside with the panel pins supplied.

Important: All windows must be sealed inside and out with silicone or any other watertight solution of your choice (not supplied).

Tip: Leaving the backing film on whilst installing will prevent scratches on your perspex or glass.

10. Corner Strips

10.a Secure the corner strips at each corner of the shed with the 40mm nails provided.

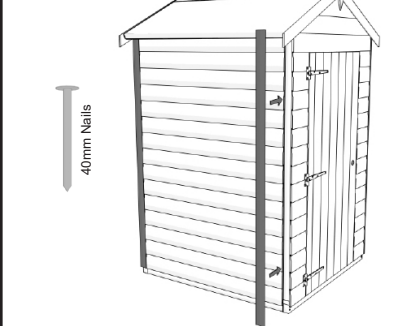

Important: Please do not confuse these corner strips as window beading. Also please be aware that the strips may need cutting to length.

11. Larger Models

If you have the 8x4 or 12x4 model, there are a few extra steps you will need to take to complete your building.

Joining the Floor Panels

These are simply butted up against each other. There is no need for any fixings as the shed, which is built on top, will hold them together. Don't forget to attach the heavy duty bearers to the panels, one on each end of the complete floor. **See Image A.**

Joining the Side Panels

These are attached using the 50mm screws provided, through the internal framework. You are supplied extra cover strips to cover the external join. These can be fitted at the end of the build as you would with smaller models. **See Image B.**

Internal Trusses (8ft and 12ft Models Only)

Not to confuse with the gable tops, they can be identified by cladding fixed to both sides of the framing. The truss should be fixed by nailing down through the framing in to the side panels using 65mm nails (**Image C**). The larger models come with 1 or 2 trusses to support the weight and the joins of the roof, because of the way the Flex Apex is manufactured, assembly of the the roof/trusses varies with each size, please **See Image D** and **E** below for instructions on 8x4 and 12x4 roofs.

Roof Panels

These are fitted in much the same way as the smaller model, just make sure on the larger models that the join of the panels is centered over the truss. **See Image D and E**

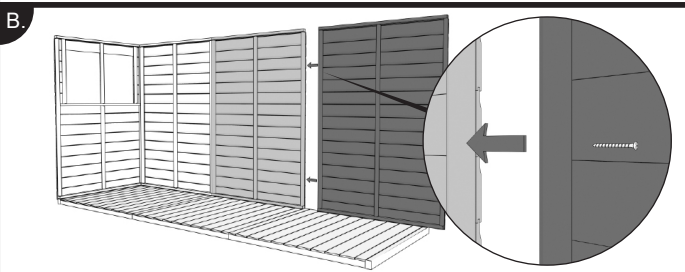
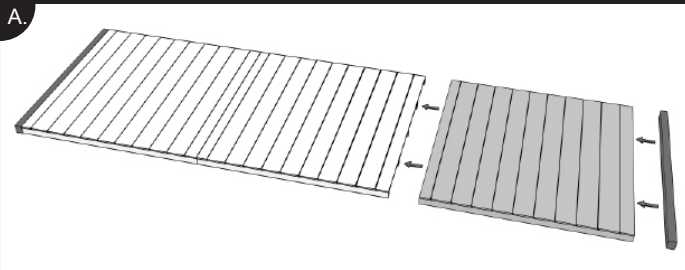

Check List

4x4 Pack

- x1 Floor
- x2 Gable Tops
- x2 Blank Panels
- x1 Window Panel
- x1 Door Panel
- x1 Door
- x2 Roof Panels
- x2 Heavy Duty Bearers

8x4 Pack

- x2 Floor
- x2 Gable Tops
- x3 Blank Panels
- x2 Window Panels
- x1 Door Panel
- x1 Door
- x4 Roof Panels
- x2 Heavy Duty Bearers
- x1 Truss

12x4 Pack

- x3 Floor
- x2 Gable Tops
- x4 Blank Panels
- x3 Window Panels
- x1 Door Panel
- x1 Door
- x6 Roof Panels
- x2 Heavy Duty Bearers
- x2 Trusses

- (found in polytube pack)
- x4 Bargeboards
 - x2 Diamond Finials
 - x4 Corner Strips
 - Fixing Kit
 - Instructions

- (found in polytube pack)
- x4 Bargeboards
 - x2 Diamond Finials
 - x6 Corner Strips
 - Fixing Kit
 - Instructions

- (found in polytube pack)
- x4 Bargeboards
 - x2 Diamond Finials
 - x8 Corner Strips
 - Fixing Kit
 - Instructions

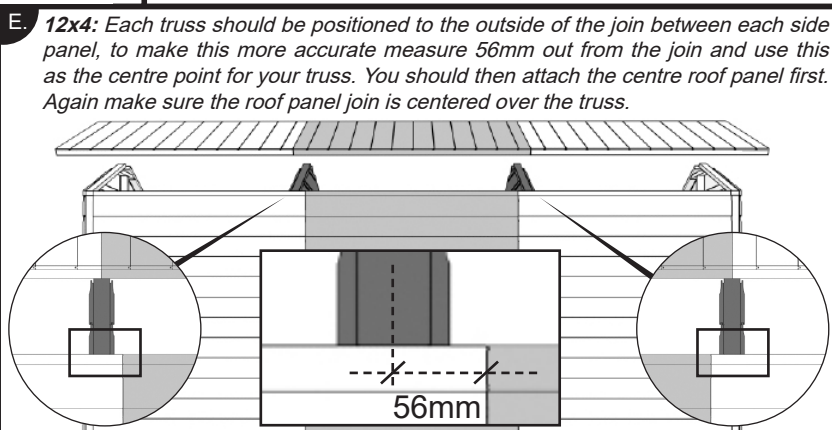
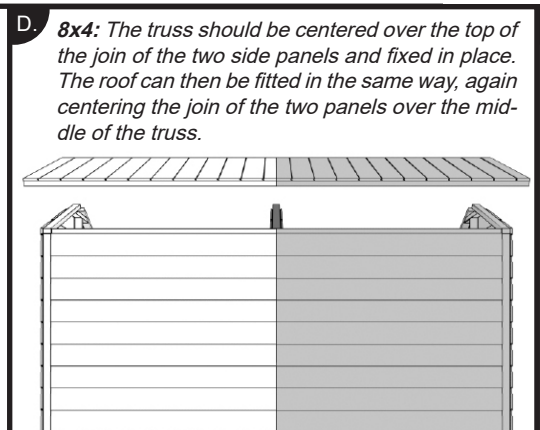
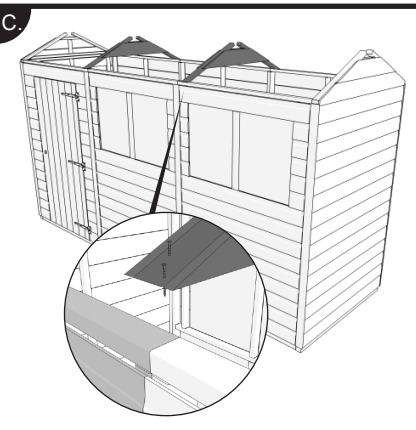

C.

D.

E.

8x4: The truss should be centered over the top of the join of the two side panels and fixed in place. The roof can then be fitted in the same way, again centering the join of the two panels over the middle of the truss.

12x4: Each truss should be positioned to the outside of the join between each side panel, to make this more accurate measure 56mm out from the join and use this as the centre point for your truss. You should then attach the centre roof panel first. Again make sure the roof panel join is centered over the truss.

56mm