

UNIQUE[®]

APPLIANCES

== *Classic* ==
by UNIQUE

CLASSIC RETRO BY UNIQUE 30" INDUCTION RANGE 30" (76.2 cm)

MODEL NUMBER: UNQ-30CR IC W, UNQ-30CR IC B, UNQ-30CR IC LG, UNQ-30CR IC T



Intertek
5010059



Intertek
EP 5024195

OWNER'S GUIDE
serial number:

JAN24V1

CLASSIC RETRO 30" (76.2 CM) INDUCTION RANGE

Installation & Owner's Manual

This manual contains information for:

- Important Safeguards
- Installation
- Use and Care

Certain ranges come equipped with special features. Determine from a study of your range which of the instructions given in this booklet pertain to your range.

This booklet gives valuable instructions covering the installation, adjustment and use of your range.

How to Obtain Service and/or Parts

If your range does not operate in accordance with the instructions in the manual, you should contact the dealer in your immediate vicinity for service. Or, the purchaser may contact the service organization noted on the warranty.

IMPORTANT

TO THE OWNER OF THE RANGE: Retain this owner's manual for future reference.

TO THE INSTALLER: Leave this owner's manual with the range.

Read and save these instructions



UNIQUE[®]

APPLIANCES

MANUFACTURED & CERTIFIED BY
Unique Appliances Ltd



⚠ WARNING

To reduce the risk of tipping the appliance by abnormal usage or improper door loading, the appliance must be secured by properly installing the Anti-Tip device packed with the appliance. To check if the device is installed and engaged properly, carefully tip the range forward. The Anti-Tip device should engage and prevent the range from tipping over.

If this range is removed for any reason, service or cleaning, etc., it must be replaced as outlined in the installation instructions before placing the range back in operation.

X2



Range Foot Anti-tip Bracket

Making sure the anti-tip bracket is installed:

- Slide range forward.
- Look for the anti-tip bracket securely attached to floor.
- Slide range back so rear range foot is under anti-tip bracket.

TABLE OF CONTENTS

IMPORTANT SAFETY NOTES	6
BEFORE INSTALLING YOUR RANGE	10
GROUNDING INSTRUCTIONS	11
HOW TO INSTALL THE BACKSPLASH.	11
HOW TO INSTALL CONTROL KNOBS	12
ANTI-TIP BRACKET INSTALLATION	13
WALL CLEARANCES & ANTI-TIP LOCATION	14
PARTS & FEATURES	17
GETTING TO KNOW YOUR INDUCTION RANGE	18
RANGE CONTROLS	20
OPERATION OF RANGE	22
OPERATION OF OVEN	24
CARE & MAINTENANCE.	26
TROUBLESHOOTING GUIDE	29
ERROR CODES	31
WIRING DIAGRAM	32
RATING LABEL	33
WARRANTY.	34
APPLIANCE INFORMATION.	35
PRODUCT REGISTRATION	35
CONTACT US	35

WELCOME

Congratulations on your purchase of a UNIQUE range! We are very proud of our product – and are committed to providing you with the best service possible. Your satisfaction is our #1 priority. Please read this manual very carefully. It contains valuable information on how to properly maintain your new Unique induction range.

We know you will enjoy your new range and thank you for choosing one of our Unique Appliances! We hope you will consider us for future purchases.

NEED HELP?

PLEASE READ AND SAVE THESE INSTRUCTIONS

This manual provides specific operation instructions for your model. Use your range only as instructed in this manual. These instructions are not meant to cover every possible condition and situation that may occur. Common sense and caution must be practiced when installing, operating and maintaining the appliance.

Record in the space provided below the Model No. and Serial No. of this appliance.

These numbers are found on the serial plate located at the bottom drawer.

Model No. _____

Serial No. _____

Purchase Date _____

Record these numbers for future use.

IMPORTANT: Keep a copy of your bill of sale. The date on the bill establishes the warranty period should service be required. If service is performed, it is in your best interest to obtain and keep all receipts.

Right now:

Please visit our website at <https://UniqueAppliances.com/product-registration/> to register your product.

IMPORTANT SAFETY NOTES

USER SERVICING: Do not repair or replace any part of the appliance unless specifically recommended in this owner's guide. Only a qualified technician should do all other servicing. This will reduce the risk of personal injury and damage to the range.

Storage in or on appliance: Flammable materials should not be stored in an oven, near surface elements or in the broiler section. This includes paper, plastic and cloth items, such as cookbooks, plastic ware and towels, as well as flammable liquids. Do not use the oven for storage. Do not store explosives, such as aerosol cans, on or near the range.

Remove the oven door from any unused range if it is to be stored or discarded.

Stepping, leaning or sitting on the doors or broiler section of this range can result in serious injuries and cause damage to the range.

The following situations could cause bodily injury or property damage:



DO NOT TOUCH INTERIOR SURFACES OF THE OVEN. Oven elements may be hot even though off. When in use, and after cooking cook ware may become hot enough to cause burns. During and after use, do not touch, or let clothing or other flammable materials touch cook ware, oven vent openings, oven door and windows, and adjacent surfaces until they have had sufficient time to cool.



NEVER use this appliance as a space heater to heat or warm the room.

Wear proper apparel. Loose fitting or hanging garments should never be worn while using the appliance. Do not let clothing or other flammable materials contact cook ware or interior surfaces of the oven until they have had sufficient time to cool.

Never modify or alter the construction of the range. Do not remove leveling legs, panels, wire covers, anti-tip brackets or any other permanent part of the product.

When heating fat or grease, watch it closely. Fat or grease may catch fire if allowed to become too hot.

Do not use water or flour on grease fires. Smother the fire with a pan lid, baking soda or use a dry chemical or foam-type extinguisher.

Use only dry potholders. Wet or damp potholders on hot surfaces could result in burns from steam. Do not let the potholder touch heating areas. Do not use a towel or other bulky cloth instead of a potholder.



NEVER cover any slots, holes or passages in the oven bottom or cover an entire rack with materials such as aluminum foil. Doing so blocks air flow through the oven and may cause carbon monoxide poisoning. Aluminum foil linings may also trap heat, causing a fire hazard. Refer to the cleaning section of this manual for more information on the use of aluminum foil.

IMPORTANT SAFETY NOTES

WARNINGS

Destroy and recycled the carton and plastic bags after the range is unpacked. Children should not use packaging material for play. Cartons covered with rugs, bedspreads, or plastic sheets can become airtight chambers that can trap a child. Remove all staples from the carton. Staples can cause severe cuts and destroy finishes if they come in contact with other appliances or furniture.

Be safety conscious. The preparation of food on a range and in an oven requires temperatures that could cause severe burns. Before using this new appliance, carefully read and follow all instructions.



PROP 65 WARNING FOR CALIFORNIA RESIDENTS

The California Safe Drinking Water and Toxic Enforcement Act of 1986 (Proposition 65) requires the Governor of California to publish a list of substances known to the State of California to cause cancer or reproductive harm. In addition, businesses must warn customers of potential exposure to such substances

The following situations may cause serious bodily harm, death or property damage:

TO REDUCE THE RISK OF TIPPING OF THE RANGE, THE RANGE MUST BE SECURED BY A PROPERLY INSTALLED ANTI-TIP BRACKET PROVIDED WITH THE RANGE. TO CHECK IF THE DEVICE IS INSTALLED AND ENGAGED PROPERLY, CAREFULLY TIP THE RANGE FORWARD. THE ANTI-TIP DEVICE SHOULD ENGAGE AND PREVENT THE RANGE FROM TIPPING OVER. REFER TO THE INSTALLATION INSTRUCTIONS PACKAGED WITH THE ANTI-TIP BRACKET FOR PROPER ANTI-TIP BRACKET INSTALLATION. See page 14 for details.

- **Never leave children alone or unattended in the area where an appliance is in use.** They should never be allowed to sit or stand on any part of the appliance. Never leave the oven door open when the range is unattended.
- **Do not store items of interest to children in the cabinets above a range or on the backguard of a range.** Children climbing on the range to reach the items could be seriously injured.
- **Do not allow children to climb or play around the range.** The weight of a child on an open oven door may cause the range to tip, resulting in serious burns or other injury.

IMPORTANT: Observe all governing codes and ordinances. Do not obstruct flow of heat and ventilation.

IMPORTANT SAFETY NOTES

Placement of oven racks: Always place an oven rack in the desired location while the oven is cool. If a rack must be moved when the oven is hot, use potholders and grasp the rack with both hands to reposition. Do not let potholders contact hot oven walls. Remove all cookware from the rack before moving.

Do not heat unopened food containers. Build-up of pressure may cause the container to burst and result in injury.

Keep the oven vent duct unobstructed. The oven vent is located along the bottom of the back guard. Touching the surfaces in the vent area when the oven is being operated may cause severe burns. Also, do not place plastic or heat-sensitive items on or near the oven vents. These items could melt or ignite. The range requires adequate ventilation for heat dissipation. Do not block the flow of air around the base or beneath the lower front panel of the range.

Use care when opening oven door: Stand to the side of the oven when opening the oven door. Slowly open the door to allow hot air or steam to escape before removing or replacing food.

Know which knob controls each element. Place a pan of food on the element before turning it on, and turn the element off before removing the pan.

Cookware handles should be turned inward and not extend over adjacent surface elements as to reduce the risk of burns, ignition of flammable materials, and spillage due to unintentional contact with the cookware.

Never leave the surface elements unattended. Boil-overs, grease and spills may catch fire, and a pan which has boiled dry may melt.

Do not place hands between the spring tension hinge and the oven door frame when you are removing the oven door. You could pinch your fingers.

Be care when touching or removing pots and pans from the range, as they will be hot. Even after the surface element has been turned off, the pot/pan is hot enough to cause burns.

When removing appliance for cleaning and/or service:

- Disconnect AC power supply.
- Carefully remove the range by pulling outward.

CAUTION: Range is heavy. Use care in handling.

NOTE: When installing or removing the range for service, a rolling lift jack should be used. Do not push against any of the edges of the range in an attempt to slide it into or out of the installation. Pushing or pulling a range (rather than using a lift jack) also increases the possibility of bending the leg spindles or damaging the internal coupling connectors.

Never clean appliance parts with flammable fluids. These fumes can create a fire hazard or explosion. And do not store or use gasoline or other flammable vapors and liquids in the vicinity of this or any other appliance. The fumes can create a fire hazard or explosion.

IMPORTANT SAFETY NOTES

Before proceeding with cleaning and maintenance operations, make sure the power line of the unit is disconnected.

Do not attempt to repair or replace any part of your appliance unless it is specifically recommended in this manual. All other servicing should be done by a qualified technician.

Clean the range regularly. Exhaust fan ventilating hoods and grease filters should be kept clean. Do not allow fat or grease to accumulate. Greasy deposits in the fan could catch fire. Refer to the hood manufacturer's instructions for cleaning.

Use Induction-ready cookware: Only cast iron, enamelled cast iron, some stainless steel and induction-ready cookware can be used with an induction range. Check the manufacturer's recommendations for rangetop use, and consult page 18 for more information.

Do not use a wok equipped with a metal ring. Only flat bottomed woks are suitable.

Use proper pan size: This appliance is equipped with one or more surface units of different sizes. Select pots with flat bottoms large enough to cover the surface of the induction heating element.

WARNING: Do not place lids flat (seal side down) on top of glass cooking surface when hot, as this could crack the cooktop. Heat trapped between the lid and the glass cooktop can create a strong vacuum seal which could shatter the glass (This is not covered by your warranty).

Do not clean the oven door gasket. The door gasket is essential for a good seal. Care should be taken not to rub, damage or move the gasket.

Do not cook on broken cooktop: cleaning solutions and spill overs may penetrate the broken cook top and create a risk of electric shock. Contact a qualified technician immediately.

Clean cooktop with caution: use soap and water to clean the cooktop after use. Do not use abrasive cleansers, or cleansers that produce reactions or noxious fumes.

It's good practice for each household to have an appropriate fire extinguisher for use in the event of a house fire.

THE INSTRUCTIONS APPEARING IN THIS OWNER'S GUIDE ARE NOT MEANT TO COVER EVERY POSSIBLE CONDITION AND SITUATION THAT MAY OCCUR. COMMON SENSE AND CAUTION MUST BE PRACTICED WHEN OPERATING AND MAINTAINING ANY APPLIANCE.

BEFORE INSTALLING YOUR RANGE



HAVE THIS RANGE INSTALLED BY A QUALIFIED INSTALLER.

Improper installation, adjustment, alteration or maintenance can cause injury or property damage. Consult a qualified installer or service agency. It must be properly positioned and installed as described in this manual, so read the manual carefully. To reduce the risk of fire, electrical shock or injury when using the appliance, follow basic precaution, including the following:

BEFORE INSTALLING YOUR INDUCTION RANGE:

- Remove the exterior and interior packing.
- Remove the protective film on steel and aluminum parts.
- Check to be sure you have all of the parts listed below.
 - 1 backsplash
 - 2 anti-tip brackets
 - 2 oven racks
 - 4 screws for backsplash
 - 1 instruction/installation manual
 - Air fryer crisper tray and pan
- Wipe down the interior and exterior surfaces with lukewarm water and a soft cloth.

IMPORTANT

- Have your range installed and properly grounded by a qualified installer in accordance with the installation instructions
- Do not attempt to repair or replace any part of your range unless it is specifically recommended in this manual.
- Do not remove permanently affixed labels, warnings, or plates from the unit. This may void the warranty.
- The installer should leave these instructions with the consumer who should retain for local inspectors use and for future reference,
- Please observe all local and national codes and ordinances.

REPLACEMENT PARTS

Only authorized replacement parts may be used in performing service on the range. Replacement parts are available from factory authorized parts distributors. Contact the nearest Unique parts distributor in your area.

For your safety, ensure that your appliance is properly installed and grounded by a qualified technician

GROUNDING INSTRUCTIONS



WARNING



ELECTRICAL SHOCK HAZARD

- Plug into a grounded 4-prong outlet. Ensure proper ground exists before using the range.
- Do not remove ground prong.
- Do not use an adapter or extension cord.

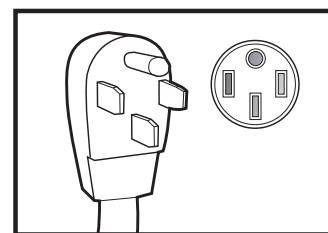

FAILURE TO FOLLOW THESE INSTRUCTIONS CAN RESULT IN DEATH, FIRE, OR ELECTRICAL SHOCK.

FOR PERSONAL SAFETY, THIS APPLIANCE MUST BE PROPERLY GROUNDED.

This appliance is equipped with a four-prong grounding plug for your protection against shock hazard and should be plugged directly into a properly grounded socket. Do not cut or remove the grounding prong from the plug.

Do not under any circumstances cut or remove the green color (ground) prong from the power plug. Electrical installation should comply with national and local codes.

It is recommended that a separate circuit, serving only your appliance be provided. Use receptacles that cannot be turned off by a switch or pull chain.

HOW TO INSTALL THE BACKSPLASH

STEP 1

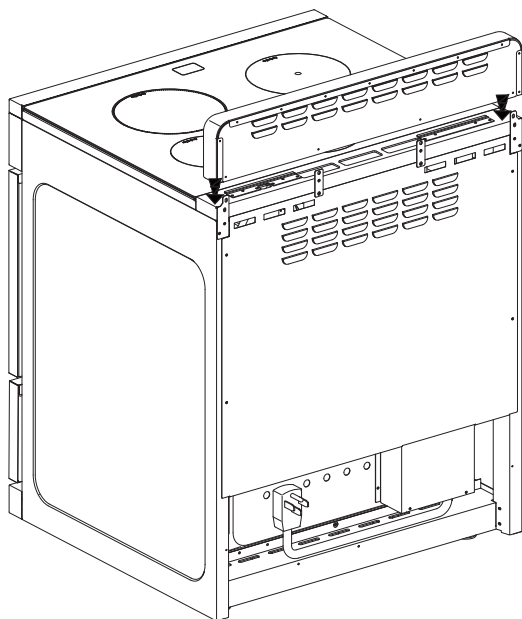

1. Align the backsplash to the rear part of the cooktop as shown in the diagram.

STEP 2

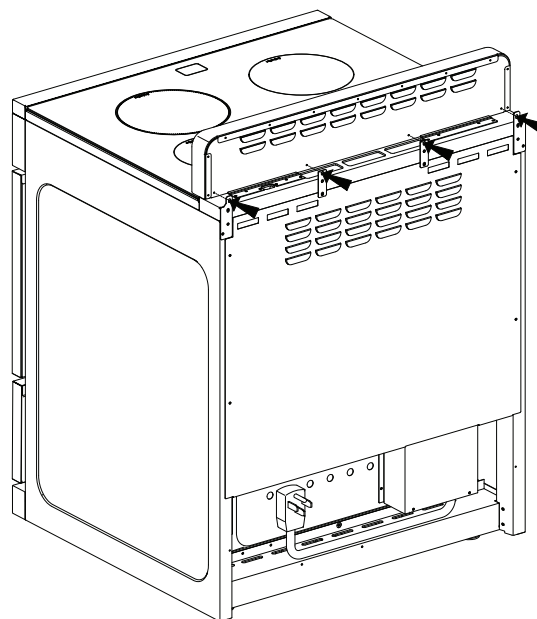

2. Secure the backsplash to the cooktop from the back using the 4 Phillips head screws provided as shown in the diagram.

HOW TO INSTALL CONTROL KNOBS

STEP 1

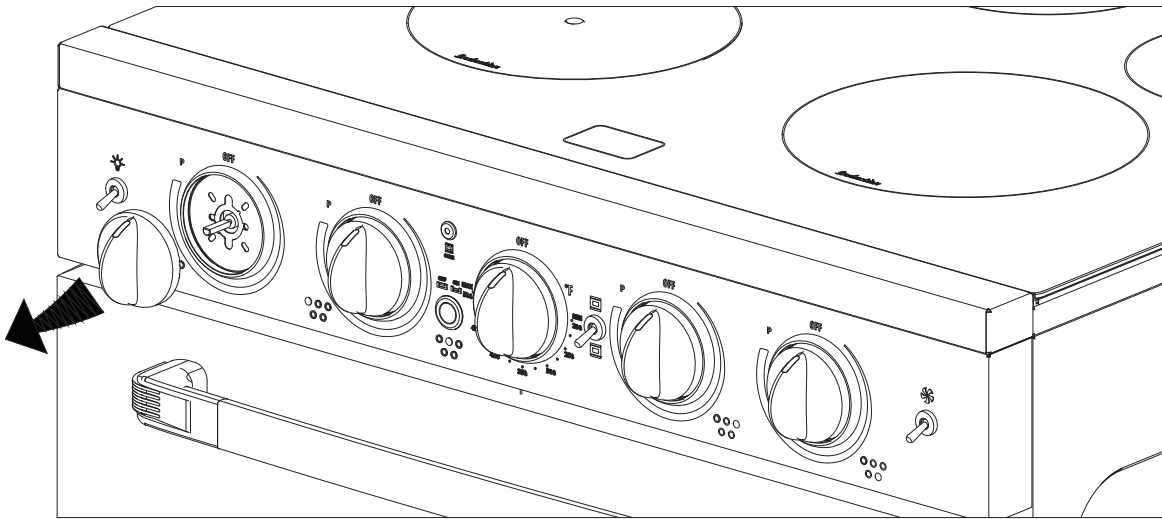

1. To replace knobs, pull existing knob straight out and off stem.

STEP 2

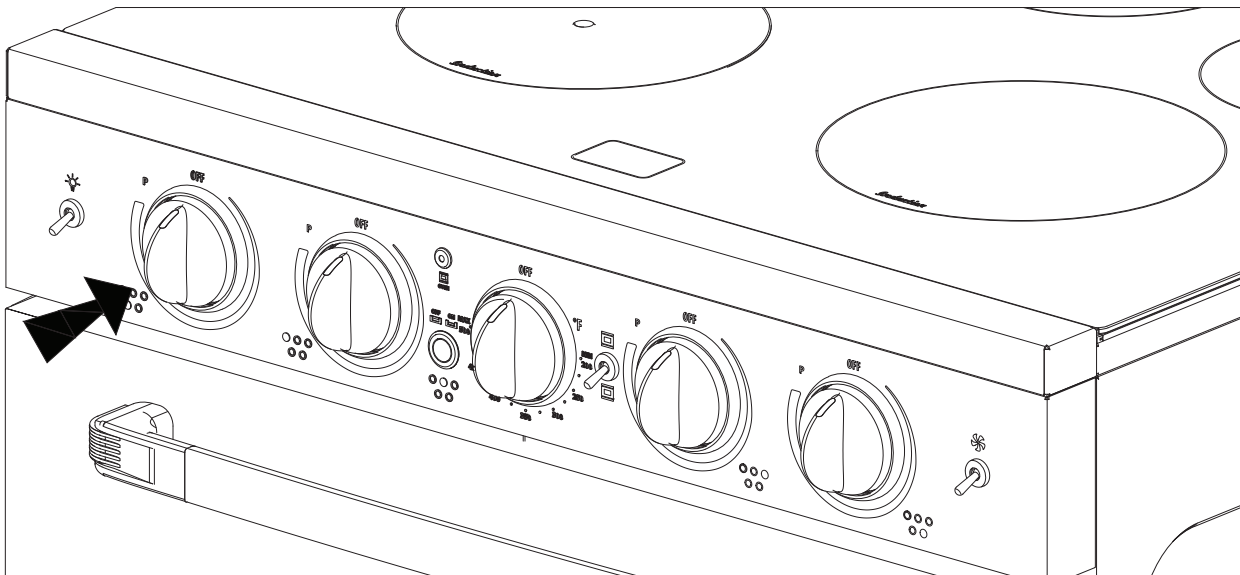

2. Position new knob on the stem with the indicator mark pointing upwards to OFF, and slowly push it into place.

ANTI-TIP BRACKET INSTALLATION

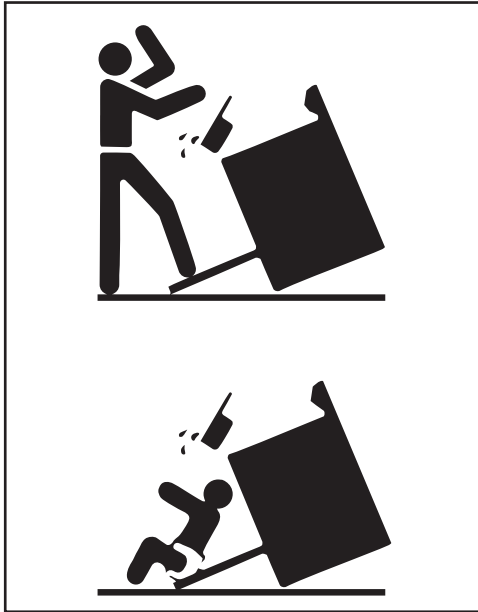

WARNING

A child or adult can tip the range and be seriously injured or killed. Install the anti-tip device to the structure and/or the range. Verify the anti-tip device has been properly installed and engaged. If the range is moved, be sure to re-engage the range to the anti-tip device.

Do not operate the range without the anti-tip device in place and engaged. See installation instructions for details. Failure to do so can result in serious burns and/or death to children or adults.

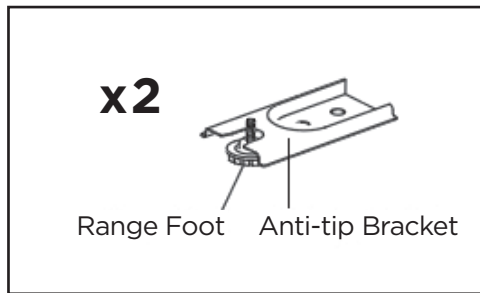

MAKING SURE THE ANTI-TIP BRACKET IS INSTALLED

- Slide the range forward
- Look for the anti-tip bracket securely attached to floor
- Slide range back so that the rear range foot is under the anti-tip bracket.
- **NOTE:** Refer to page 14 for clearances required for installing the anti-tip brackets.
- **NOTE:** Refer to page 16 for how to connect the range to the anti-tip brackets.

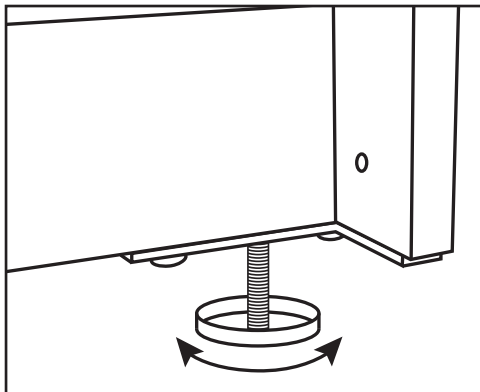

LEVELLING A FREE-STANDING RANGE

All free-standing ranges must be level to obtain proper cooking results. The leveling legs should be screwed into the corner brackets. Place pan or measuring cup partially filled with water vor a level on the oven rack. Adjust the leveling legs by hand until the range is level. The top of the side panels should be level with the counter top.

WALL CLEARANCES & ANTI-TIP LOCATION

IMPORTANT: Save these instructions for electrical inspector's use.

To eliminate the risk of burns or fire by reaching over heated surface units, cabinet storage space located above the surface units should be avoided. If cabinet storage is to be provided the risk can be reduced by installing a range hood that projects horizontally a minimum of 5 inches beyond the bottom of the cabinets.

IN THE EVENT OVERHEAD CABINETS ARE INSTALLED, THE MAXIMUM DEPTH OF CABINETS INSTALLED ABOVE COOKING TOPS SHOULD BE 13".

All units must be installed in accordance to minimum rear and side wall clearance and clearances extended vertically above cooking top which are stated on the serial plate located at the back of the range.

ANY OPENINGS IN THE WALL BEHIND THE UNIT AND IN THE FLOOR UNDER THE UNIT MUST BE SEALED.

Note: Due to potential hazards it is recommended that storage cabinets NOT be installed above the cooking surface.

ELECTRIC RANGE - REQUIRED CLEARANCES

- A - From side of counter to side of range: 0"/0 cm
- B - From side of counter to edge of opening for range plug: 2"/5 cm
- C - From side of counter to outer edge of anti-tip bracket: 1.5"/3.8 cm
- D - Width of opening for range plug: 15.7"/39.8 cm
- E - Height of opening for range plug: 7"/17.8 cm

ELECTRICAL CONNECTION CLEARANCES

If range outlet is situated within the "opening for range plug" (as shown), the plug will fit within this opening and the range will sit flush against the wall.

If the outlet is situated elsewhere, the range will require an allowance of at least 1.25" (3.2 cm) between the wall and the back of the range to accommodate the plug.

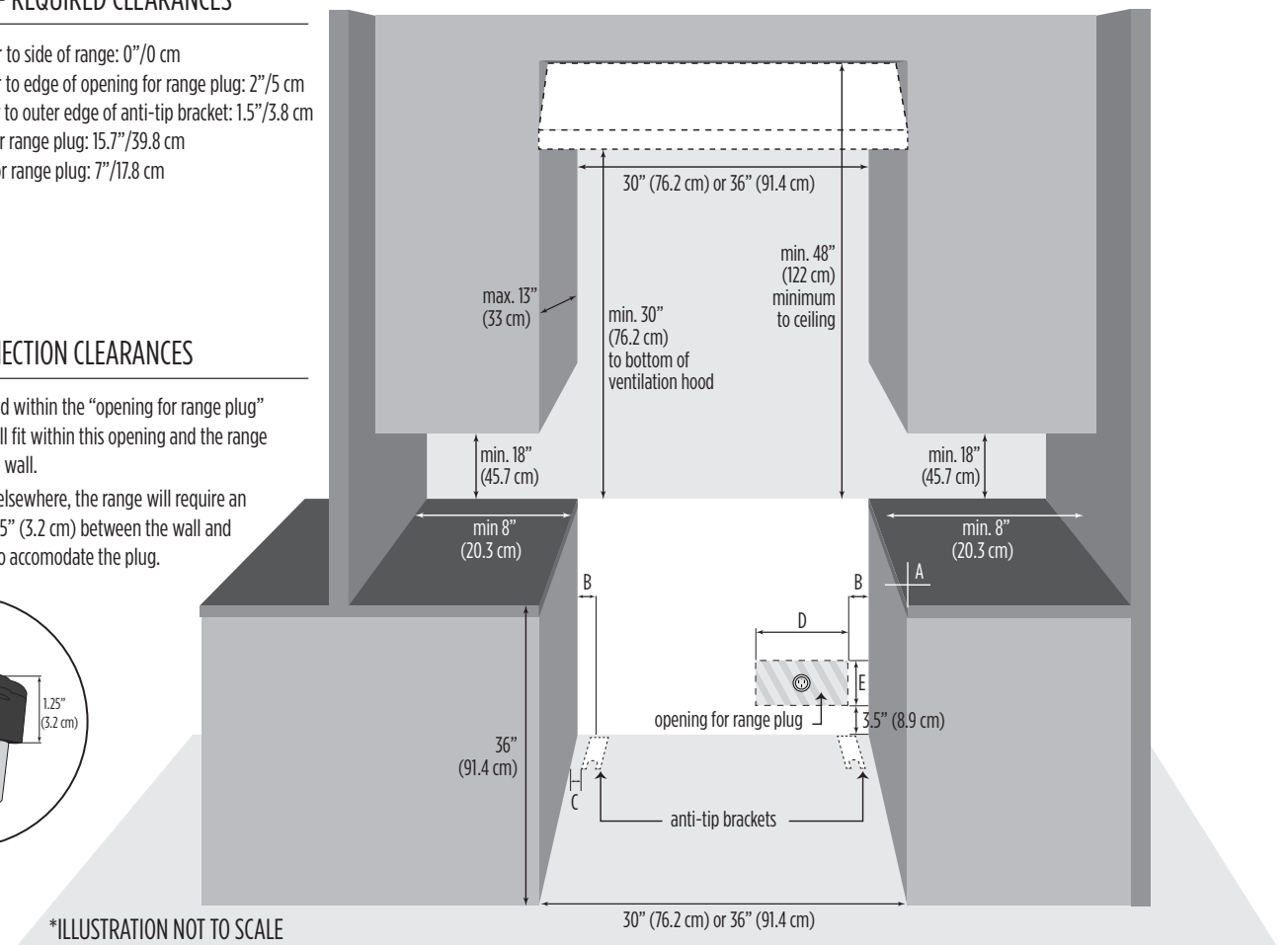
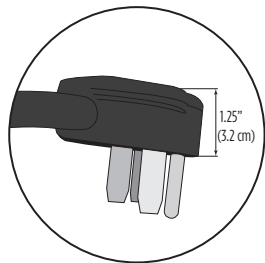

WALL CLEARANCES & ANTI-TIP LOCATION (continued)

BACK OF THE APPLIANCE FOR PLUG PLACEMENT

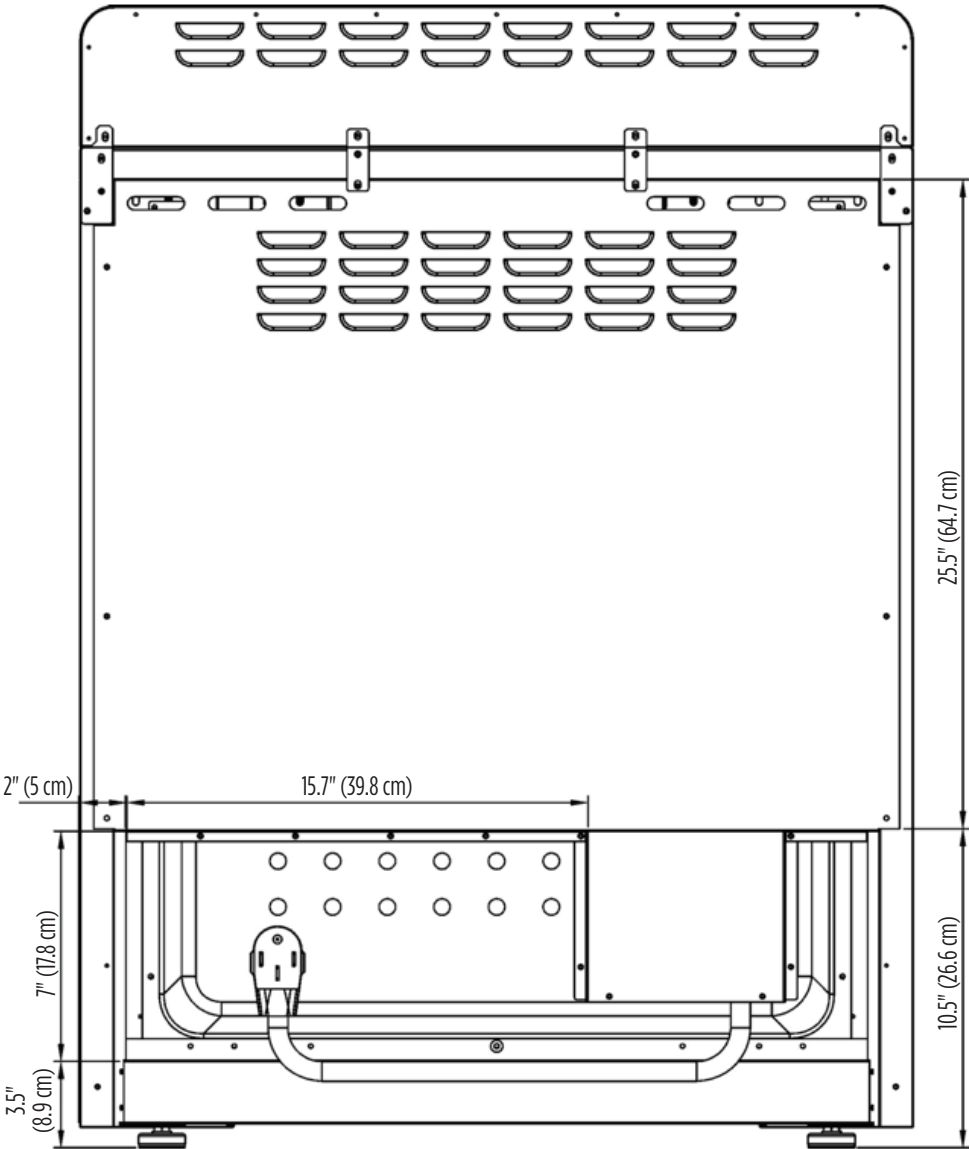

WALL CLEARANCES & ANTI-TIP LOCATION (continued)

ANTI-TIP BRACKET LOCATION

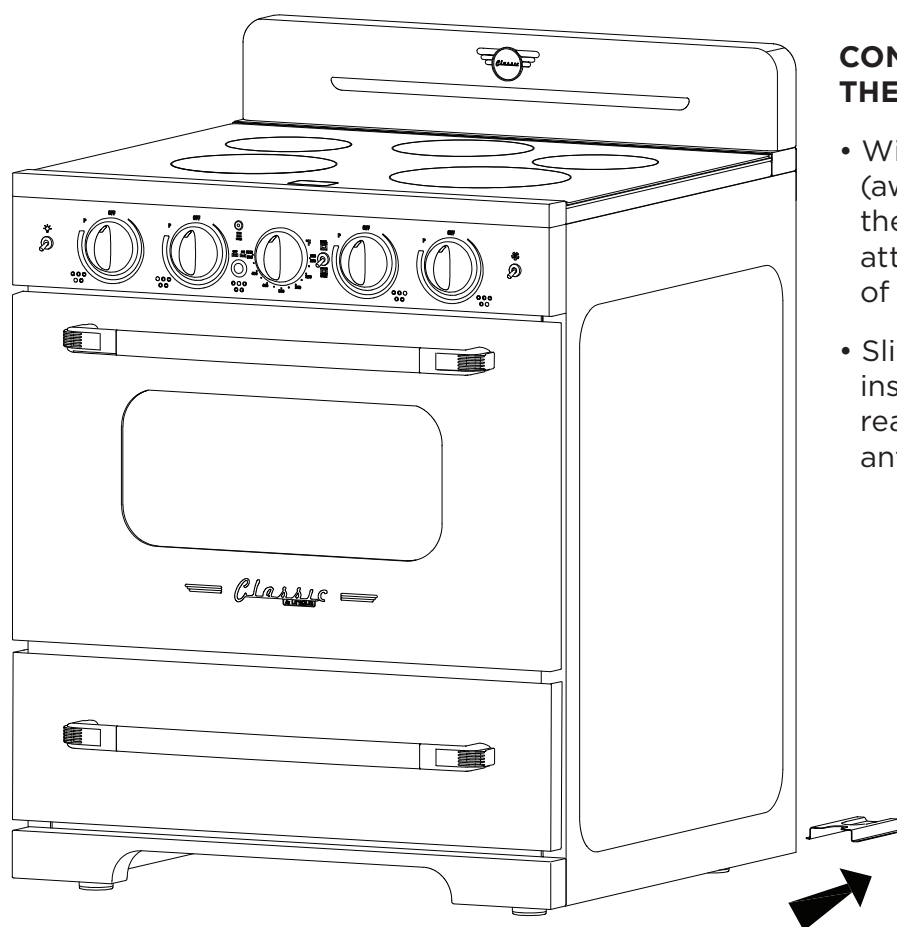
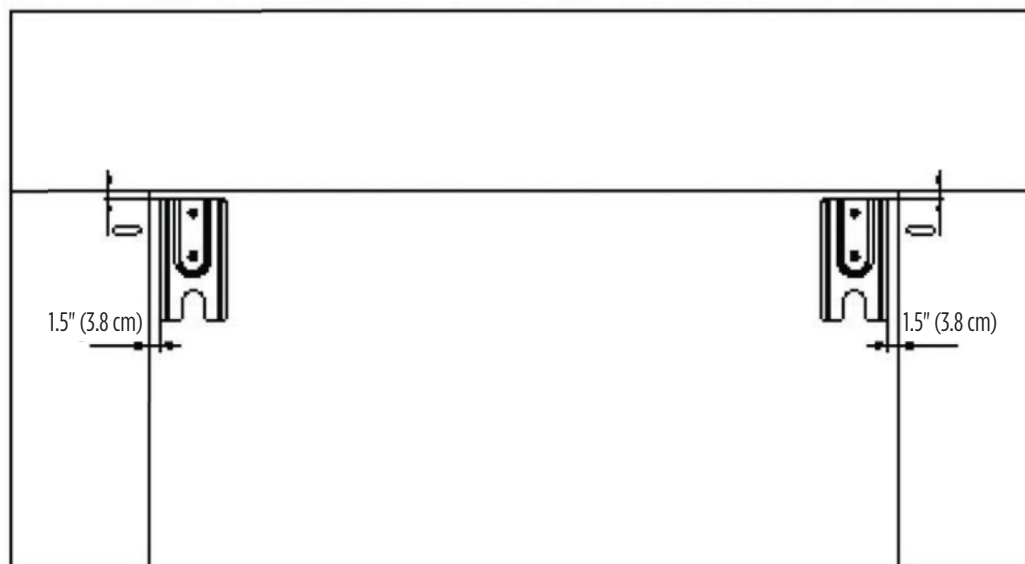

CONNECTING THE RANGE TO THE ANTI-TIP BRACKET

- With the range slid forward (away from the wall), look for the anti-tip brackets securely attached to floor on either side of the range.
- Slide range back into its installed position so that the rear range feet slide under the anti-tip brackets.

PARTS & FEATURES

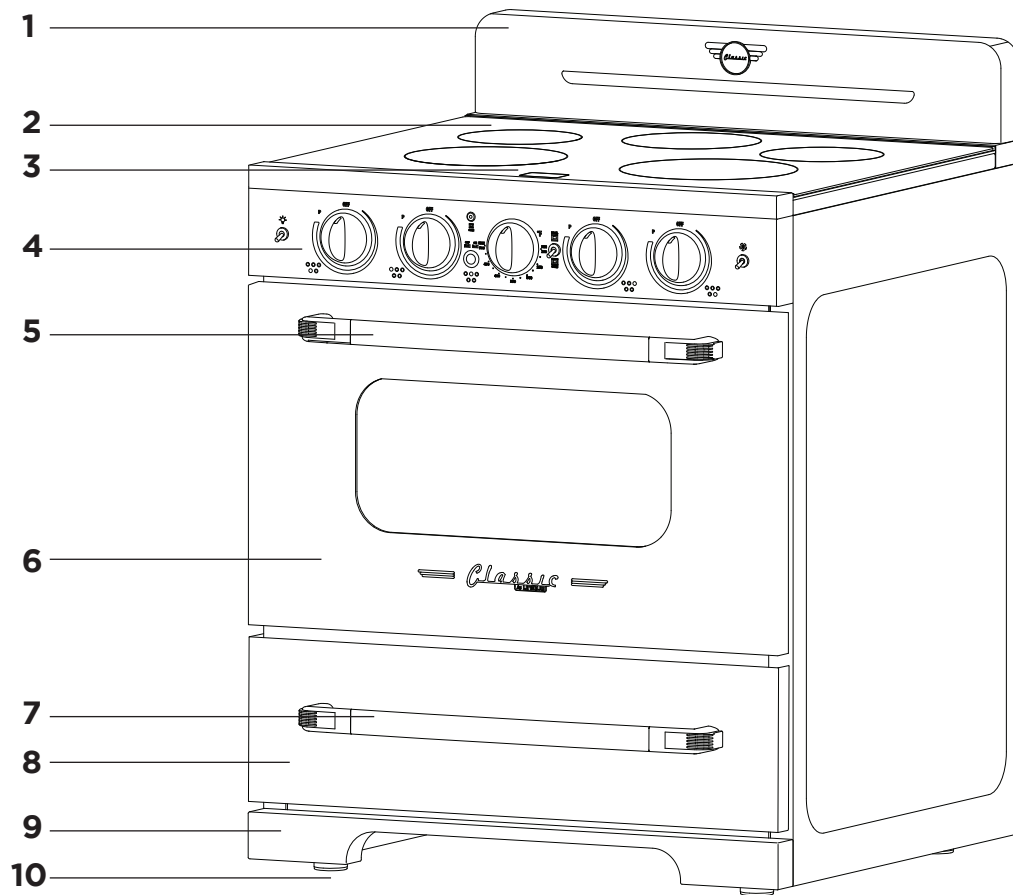

1. Backsplash with integrated oven vents
2. Cooktop
3. Display panel
4. Control panel
5. Oven handle
6. Oven door
7. Storage drawer handle
8. Storage drawer
9. Kick plate
10. Leveling legs (4)

GETTING TO KNOW YOUR INDUCTION RANGE

HOW YOUR INDUCTION RANGE WORKS

Induction ranges create an electromagnetic current that oscillates between copper coils within the cooktop surface and the cookware itself, creating the heat that cooks your food. Because this reaction occurs between the connection of cookware and cooktop, there is no physical heat created on the cooktop.

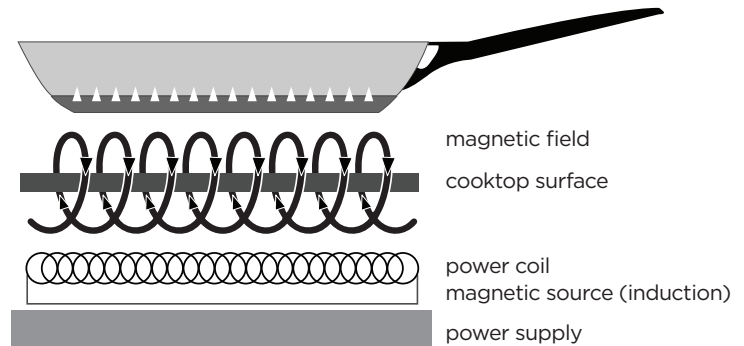

INDUCTION COOKING IS:

Faster - Induction cooktops heat up quickly, and allow for immediate and precise adjustments to cooking temperature - no waiting for burners to heat up or cool down to achieve the ideal cooking temperature.

Efficient - Induction cooktops use much less energy than traditional electric or gas cooktops, cook food more quickly, and don't create residual heat, resulting in a cooler kitchen.

Safe - Since the induction cooktop only heats the cookware, the cooktop remains cool to the touch, significantly reducing the risk of kitchen fires and/or accidents.

Easy to clean - With no heat generated on the surface of the induction cooktop, spills or messes don't burn or cook on to the surface, making them easy to wipe up.

INDUCTION COOKWARE: WHAT WORKS, AND WHAT DOESN'T

Because induction cooking uses an electromagnetic current to create heat, induction cookware needs to be magnetic. Non-ferrous cookware such as aluminum, copper and do not work with induction cooktops; instead, choose cast iron, porcelain-enamelled cast iron, stainless steel or induction-ready cookware (identified by this logo.)



How to test cookware for induction range compatibility:

- hold a magnet close to the bottom of the pot
- if the magnet pulls itself to the pot quickly and holds firm, this pot is induction-ready
- if the magnet's draw is weak or non-existent, this pot isn't suitable for induction cooking

In order to maximize the contact between the cookware and the element, choose pots/pans that have flat bottoms. Cookware that makes full contact with the element will produce the best results; pots/pans with curved or warped bottoms will not heat evenly. Round cookware that fits within the element ring is your best choice; cookware larger than the element ring can be used, but heating will occur only above the element (within the ring's diameter.)

For wok cooking, only use a flat-bottomed wok. Do not use a wok with a support ring as the wok will not contact the element.

NOTE: The warming zone is NOT an induction element, therefore it will work with flat-bottomed pots/pans that are not specified for induction cooking.

GETTING TO KNOW YOUR INDUCTION RANGE (continued)

PREPARING YOUR INDUCTION COOKTOP

Before using your induction cooktop for the first time, wipe the cooktop surface down with a ceramic cooktop cleanser and remove any residue with a clean paper towel or soft cloth. This will leave a protective finish on the cooktop that helps to protect against marks and scratches, and makes any cooking residue easier to clean up.

A NOTE ABOUT INDUCTION NOISE

Because induction heating is a magnetic function, some light vibration can occur with some kinds of cookware, particularly those pots and pans that aren't perfectly flat on the bottom, or that have loose handles or lids. Using heavier weight, high quality cookware (such as cast iron, or enameled cast iron) can help to eliminate vibrational noise.

When using more than one element, magnetic fields from adjacent elements may interact, producing a low humming or whining noise. This noise can be reduced by raising or lowering the power level settings of one or all of the elements. This humming noise is most noticeable when the elements are set to high levels. Pans that completely contact and cover the element rings will produce less noise.

Different cookware materials can produce different, normal sounds. A low buzz may be heard on element start-up if a pan's contents are cold, and will decrease as the pan heats up. You can adjust/reduce the sound of this buzz simply by adjusting the heat setting higher or lower.

INCORRECT



Cookware is not centred within the heating element ring.



Cookware has a warped bottom that isn't fully contacting the element

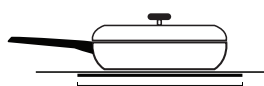

Cookware does not match the size of the heating element



Cookware rests on the cooktop trim/edge or does not contact fully with the element



Heavy handle causes the pan to tilt

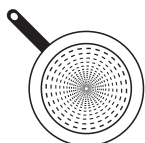

Cookware is not fully magnetic/induction compatible

CORRECT



Cookware is centred within the heating element ring.



Cookware has a flat bottom that fully contacts the element

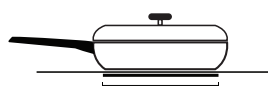

Cookware matches or is larger than the size of the heating element

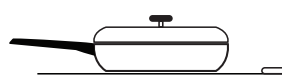

Cookware makes complete contact with the element

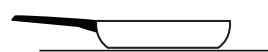

Balanced cookware ensures full contact with element



Cookware is fully magnetic/induction compatible

RANGE CONTROLS

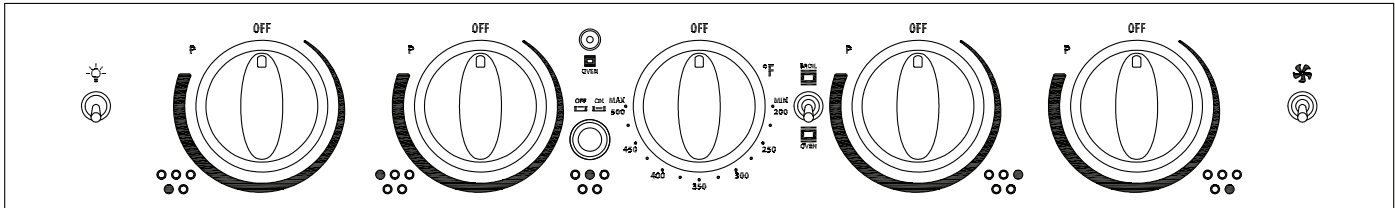

Oven light switch	
Oven on/off indicator light	
Warming zone on/off switch	
Cooktop on/off indicator light	

Convection fan switch	
Broiler	
Oven	

INDUCTION ELEMENT PLACEMENT

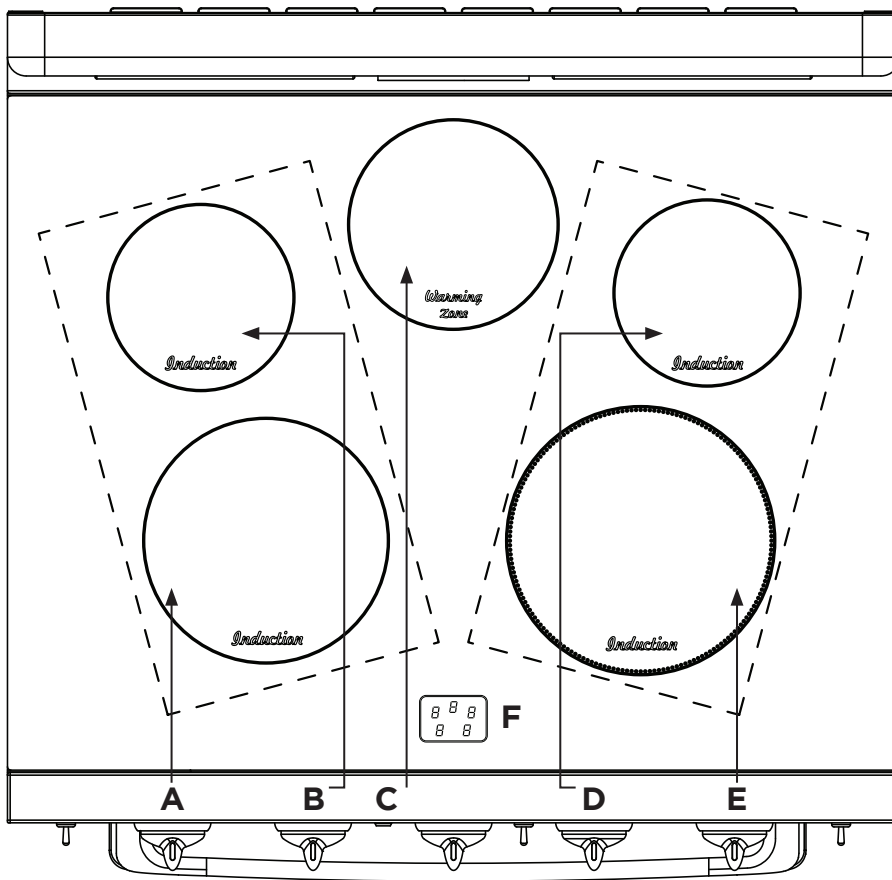

- A** Front left induction element knob
- B** Back left induction element knob
- C** Warming zone switch
- D** Back right induction element knob
- E** Front right induction element knob
- F** Display control panel

RANGE CONTROLS (continued)

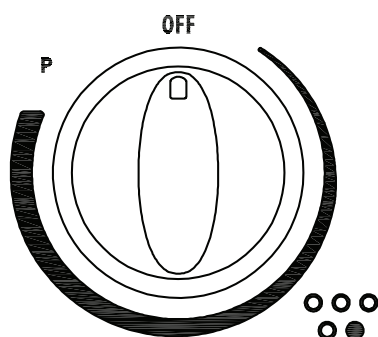

ELEMENT CONTROL

The range comes with 4 elements and a central warming zone. Each burner is designed with 9 heat settings and a Power Boost setting (P).

This induction range also has a "warming zone" to keep hot, cooked foods at serving temperature. To activate the warming zone, press the "warming zone" button in. Press again to turn the warming zone off.

NOTE: The warming zone should not be used to heat cold food.

POWER CONTROL

If an element is set to high for an extended period of time, or if additional elements are in use on the cooktop, there might be a slight reduction in the power of the element set to high. Ensure that any spills are wiped up promptly, as moisture under a pan may also cause a reduction of heating power.

NOTE: When the front right element is set to Power Boost (P), the rear right element sets to OFF. The rear right element can be used when the front right element is set to any level between MIN/1 and MAX/9.

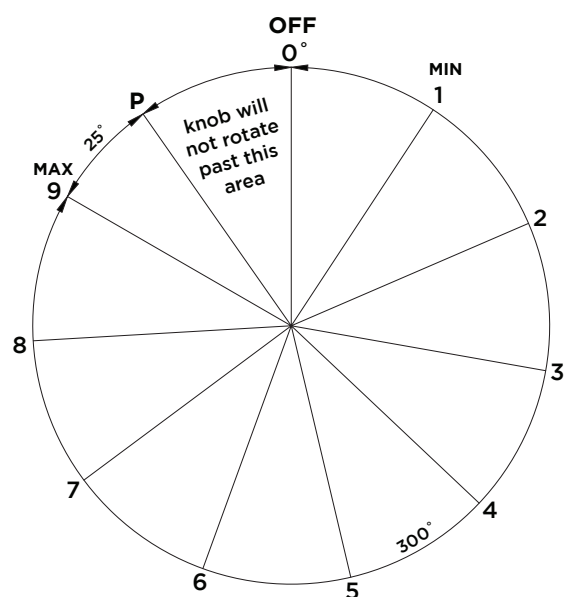

SETTING AND ADJUSTING THE ELEMENTS

- Select the desired element setting by pushing the knob in and turning it to the right (clockwise.)
- Turn the knob to "MIN/1" for the lowest temperature, to "MAX/9" high temperature, or to P for "Power Boost". You can adjust your element temperature between the MIN/1 and MAX/9 settings during the cooking process.
- To turn the element off, turn the knob to the left (counter-clockwise) to 0 (OFF). If the temperature in the element area is higher than 60°C, the setting/residual heat LED will display H on the control display panel.
- **Left Front and Left Rear group:** output power limit of 3500W
- **Right Front and Right Rear group:** output power limit of 3700W

ELEMENT LOCATION	POWER SETTINGS (watts)									
	1	2	3	4	5	6	7	8	9	POWER BOOST
LEFT FRONT	100	150	200	250	350	600	1000	1500	2300	2600
LEFT REAR	100	150	200	250	300	350	600	1000	1200	1800
RIGHT FRONT	100	150	200	250	350	600	1000	1500	2300	3700
RIGHT REAR	100	150	200	250	300	350	600	1000	1200	1800

OPERATION OF RANGE

RANGETOP CONTROL DISPLAY

WARMING ZONE

Warm settings: 0 - 1

(0 = off)

Residual heat: H

LEFT REAR BURNER

Cook settings: 0 - 9

Power Boost: P

Residual heat: H

RIGHT REAR BURNER

Cook settings: 0 - 9

Power Boost: P

Residual heat: H

LEFT FRONT BURNER

Cook settings: 0 - 9

Power Boost: P

Residual heat: H

RIGHT FRONT BURNER

Cook settings: 0 - 9

Power Boost: P

Residual heat: H

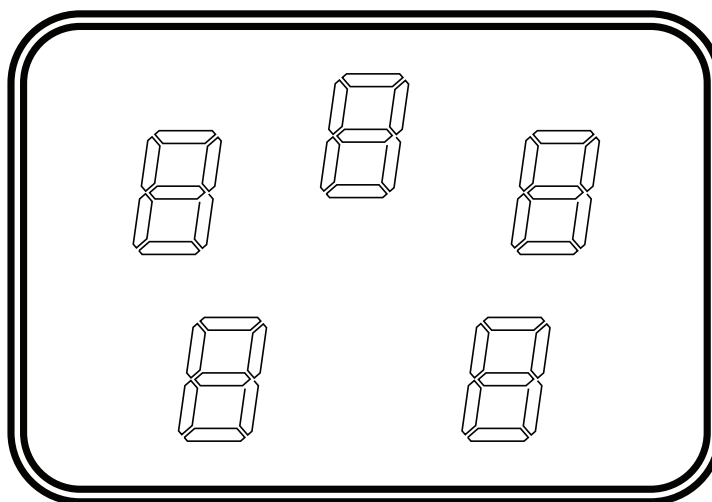

SYMBOL	FUNCTION	DESCRIPTION
	Pan Detection	If a cooking area is turned on with no pot/pan placed on it, or if the pot/pan is too small, the cooking area will not heat up. After 10 seconds, the Pan Detection symbol will display. This symbol will disappear and the element will start to heat when an appropriately sized pot/pan is placed on the cooking area. If no appropriate, flat-bottomed pot/pan is detected after 30 seconds, the control panel will display 0.
	Residual Heat	After an element has been turned off, the setting/residual heat LED will display H on the corresponding area of the control display panel if the temperature in the cooking area is higher than 60°C. Once this temperature drops below 60°C, the symbol will turn off.
	Power Boost function	The Power Boost function is a high-speed heating function available on all cooking areas. To activate Power Boost, turn the knob to P. The Power Boost function will automatically downshift to MAX/9 after 5 minutes.

OPERATION OF RANGE (continued)

SAFETY SHUTDOWN FUNCTION

The induction range has a safety shutoff feature to prevent the cooking areas from staying active for a long time, which can waste energy.

ELEMENT SETTING	SAFETY SHUTDOWN AFTER:
1-2	6 hours
3-4	5 hours
5	4 hours
6-9	1.5 hours
Power Boost	5 minutes



COOKWARE TIPS

You must use compatible cookware with your induction range - only cast iron, porcelain-enamelled cast iron, some stainless steel and induction-ready cookware can be used with an induction range. Check the manufacturer's recommendations for rangetop use, and consult page 18 for more information.

- Pots with flat bottoms maximize the contact made with the magnetic field, making cooking more efficient, while using tight-fitting lids help conserve energy and shorten cooking times.
- Pot size should match the element size. A slightly larger pan covers the entire element for better efficiency. Pots that are too small for the cooking area may trigger the Pan Detection function.
- Pots should be centred on cooking zones. Uncentered pots may lead to uneven cooking.

WARNING

Make sure that the handles of cookware do not stick out over the edge of the range, to avoid them being knocked over by accident. This also makes it more difficult for children to reach the cooking pots/pans.

- To avoid damage to the cooktop, move pots and pans gently.
- Do not use the cooktop if the glass is cracked or broken. Using the cooktop can present a risk of electric shock. Contact a qualified technician immediately.
- Avoid scratching the glass. The cooktop can be easily scratched by using items similar to knives, sharp objects/edges, and jewelry.
- Avoid storing items that can melt or possibly catch fire on the glass cooktop, even if not in use. Heat from the oven vent may cause items to melt or ignite.

OPERATION OF OVEN

HOW TO USE THE OVEN

The oven is controlled by two separate switches: the Broil/Oven switch is used to select the cooking mode, and the oven temperature knob which is used to select the desired oven temperature. You must first select the appropriate cooking mode (broil or oven/bake) and then select the desired temperature.

The oven has three different heating modes:

Broil - 3400W (upper heating element)

Oven - 3400W (lower heating element)

Oven + Fan - 4638W (lower+ back heating element)

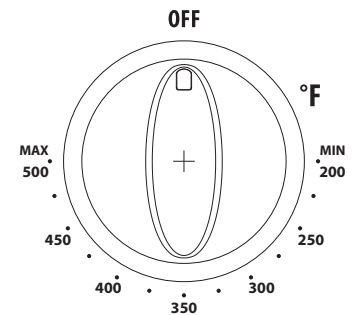

USING THE OVEN

- Switch the broil/oven rocker switch to “oven” mode
- Press the oven temperature knob in and turn it clockwise to select the desired temperature, up to 500°F max
- To switch the oven off, turn the oven temperature knob to the “Off” position

NOTE: When the oven element is on, the indicator light will be lit regardless of the setting.

ATTENTION: The oven door becomes very hot during operation, be sure to use the handle to open/close. Keep children away from the stove/oven when it is in use.

USING THE BROILER

- Switch the broil/oven rocker switch to “broil” mode
- Turn the oven temperature knob clockwise to the desired temperature on Broil
- To switch the broiler off turn the oven temperature knob to the “Off” position

To use the broiler:

- Turn the Broil/Oven control knob to Broil, and turn the Oven Temperature control knob clockwise to select the desired temperature up to 500° F. Let the broiler preheat for about 5 minutes with the door closed.
- Place food in a broiler pan with a fitted grill. Always use the grill so that the fat drips into the broiler pan, otherwise the juices may spatter or catch fire. Do not broil without using a broiler pan.
- Position the broiler pan on the second level from the top, centered under the broil element.
- To switch off the oven, turn the thermostat control and function control knobs to the “Off” position.



IMPORTANT:

Always use suitable protective gloves when inserting/removing broiler or air fryer crisper pan, shelves, trays and other cooking utensils from the oven.

The broiler function must always be used with the oven door closed.

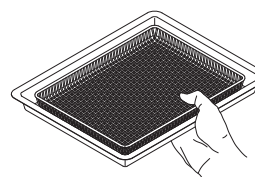

Incorrect

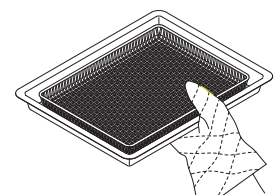

Correct

OPERATION OF OVEN (continued)

VERY IMPORTANT:

- The oven/broil should only be used with the door closed.
- Never obstruct the oven vent slots on the backsplash.
- Do not broil without using the broiling pan.
- Do not leave food under the broiler unattended.
- The cooktop surface may become hot when using the oven and/or broiler.

OVEN INDICATOR LIGHT

The oven indicator light will remain on until the oven knob is turned to the off position or the desired temperature is reached in the oven.

OVEN THERMOSTAT

- The numbers printed on the control panel indicate the increasing oven temperature valve (°F)
- To regulate the temperature, set the chosen number onto the control knob indicator.

COOKING IN FAHRENHEIT/CELCIUS

The oven temperatures are listed in degrees Fahrenheit on the knob (°F) - use the chart at right to determine the equivalent temperature in degrees Celcius (°C).

Knob setting (temperature in °F)	Corresponding temperature in °C
200	93
250	121
300	149
350	177
400	204
450	232
500	260

USING THE AIR FRYER CRISPER TRAY AND PAN

- Position the oven racks to the middle of the oven.
- Set the broil/oven rocker switch to OVEN and switch the convection fan to ON
- Turn the oven temperature knob clockwise to the desired temperature (up to 500°F) and let the oven preheat for about 5 minutes with the door closed.
- Place food in a single layer in the mesh air fryer crisper tray with its fitted pan beneath.
To promote even cooking and browning, do not over-crowd food in the crisper tray.
- Baste or mist food lightly with oil to help ensure a crispy exterior and moist interior.
- Cook food according to package/recipe directions. Food should be shaken/stirred once or twice during the cooking process to ensure even cooking and a crispy exterior.
For example: French fries cook to perfection in about 18 minutes at 400°F, shaking/stirring them halfway through the cooking time.
- When finished cooking, remove the air fryer crisper tray from the oven, turn the convection fan to OFF, and turn the oven temperature knob to the "OFF" position

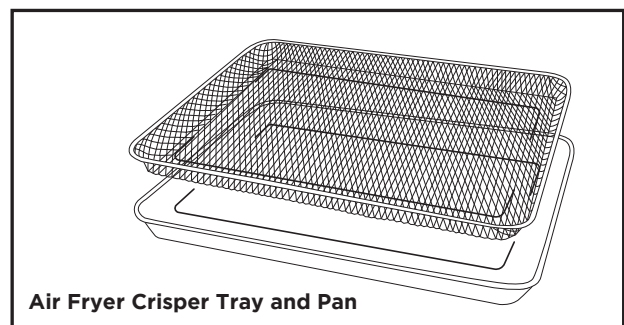

CARE & MAINTENANCE

Important: Before performing any cleaning and/or maintenance, disconnect the appliance from the electrical supply.

- It is best to clean both the range surfaces and the enameled surfaces when they are cold.
- Avoid leaving alkaline or acidic substances (lemon juice, vinegar, etc.) on surfaces.
- For best results, use cleansers specially made for cleaning induction cooktops. Avoid using cleaning products with a chlorine or acidic base.
- The oven should be cleaned after every use, using suitable products. Heating the oven to its highest temperature for 30 minutes will reduce most grime and debris to ash, making clean-up easier.

CLEANERS AND CLEANING MATERIALS

Do not use harsh cleaners or degreasers on or around functional parts (valves, controls, etc., or aluminum tubing). This will damage or drastically reduce the life of the part.

Use only a mild solution of soap and water on back guards, aluminum control panels and painted surfaces. Never use harsh abrasives or cleaning powders that may scratch or mar the surface. Make sure the cleaners and cleaning materials are suitable for use on the area to be cleaned. Always keep cleaning materials in a safe place. Never use a sharp metal scraper to clean glass, porcelain, or painted surfaces.

COOKTOP

Use a sponge and a commercial cooktop cleaner for best results. To remove heavier grease and stubborn residue, a plastic scraper can be used to help loosen residue: follow the cleaner's application instructions.

KNOBS

Pull forward on the knobs to remove them (you can slide dental floss behind the knob and use it to pull the knob forward if needed.) Wash knobs with water mixed with a mild detergent. To avoid scratches, do not use an abrasive cleaner or any abrasive action. Dry the knobs with a soft cloth and reinstall.

AIR FRYER CRISPER TRAY AND PAN

Using a soft, damp cloth, wipe away any crumbs or baked-on food residue. Place the air fryer crisper tray and pan in the dishwasher for easy clean-up, or soak both in a solution of hot water and dish detergent for 10 minutes and gently scrub any residue off with a scrub brush or sponge. Once clean, thoroughly dry both the crisper tray and pan before storing.

USING COMMERCIAL OVEN CLEANERS

Commercial oven cleaners may be used on porcelain-lined ovens; however, many cleaners are very strong, and it's important to follow instructions carefully. Ensure adequate ventilation, and be sure to wear rubber gloves to protect your hands.

After using such cleaners, thoroughly rinse the oven with a solution of 1 tablespoon vinegar to 1 cup of water. Oven cleaners can coat or damage the thermostat sensing device (the long tube in the oven) so that it will not respond to temperature accurately. If you use an oven cleaner, do not let it contact the sensing bulb, or any chrome, aluminum, or plastic part of the range.

Do not apply or allow the cleaner to come in contact with any parts or surfaces other than the oven interior.

CARE & MAINTENANCE (continued)

USING ALUMINUM FOIL IN OVEN

WARNING: Do not cover any slots, holes or passages in the oven bottom, or cover an entire rack with materials such as aluminum foil. Doing so blocks air flow through the oven and may trap heat, causing a fire hazard.

Aluminium foil, when improperly used, can be a cause of range fires. Make certain that vents or air openings aren't covered by the foil. If the vents located along the sides of the oven bottom are blocked, poor cooking will result.

Never cover a rack completely. A piece of foil slightly larger than the cookware can be placed on the rack beneath the cookware.

Remove and discard aluminum foil after each use. This will help prevent grease and spilled food from accumulating and becoming a fire hazard.

REPLACING THE OVEN LIGHT

- Let the oven cavity and broil element cool down.
- Switch off the electric supply.
- Remove the protective cover.
- Unscrew the light bulb counter clockwise.
- Replace the bulb with an E14 120V 25W 300°C bulb.
- Replace the protective cover.

NOTE: Oven bulb replacement is not covered by your warranty.

REMOVING THE OVEN DOOR FOR CLEANING

To facilitate oven cleaning, it is possible to remove the door for better access. Please follow the instructions carefully:

The oven door can easily be removed as follows:

- Open the door to fully.
- Lift the left and right hooks on the hinge figure (A,B).
- Hold the door as shown in figure (C) on a 45 degree angle.
- Gently close the door until the hooks touch the door, then lift at a 45 degree angle
- Set the door on a soft flat surface.
- To replace the door, repeat the above steps in reverse order.

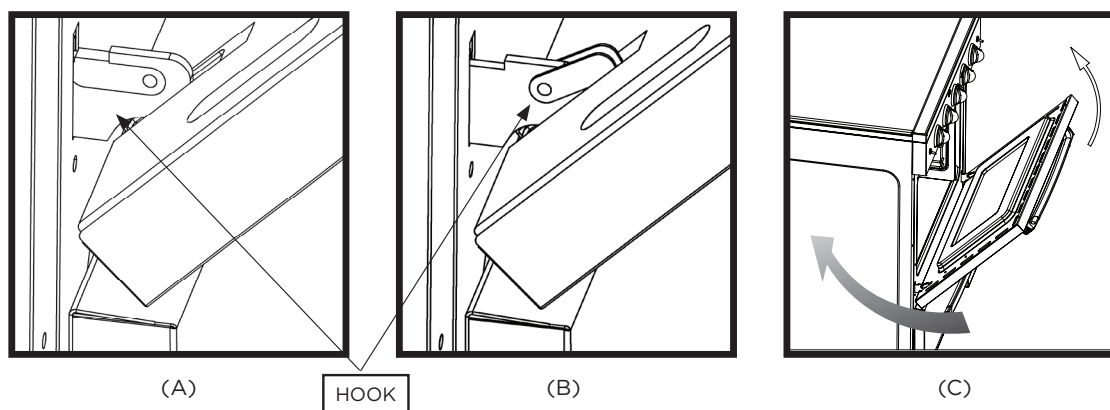

CARE & MAINTENANCE (continued)

OVEN RACK INSTALLATION AND REMOVAL

- The oven racks are provided with a safety catch to prevent accidental removal
- They must be inserted as shown
- To remove, pull the rack towards you and tilt it upwards to remove the safety catch from the side support rails
- To replace the racks, slide the safety catch between the side support rails with the rack tilted slightly upwards, then slowly lower the rack down to level as you push it all the way in

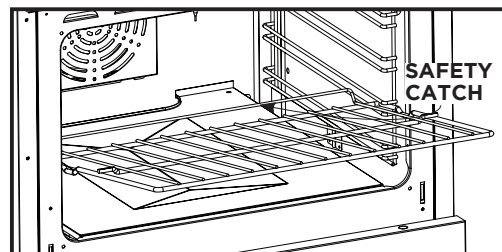

DO NOT STORE FLAMMABLE MATERIAL IN THE OVEN OR IN THE BOTTOM DRAWER

Only store heat-resistant pots, pans and trays in the drawer as it gets very hot when the oven is on.

NOTE: Do not store plastic items (or pots and pans with plastic handles) in your drawer.

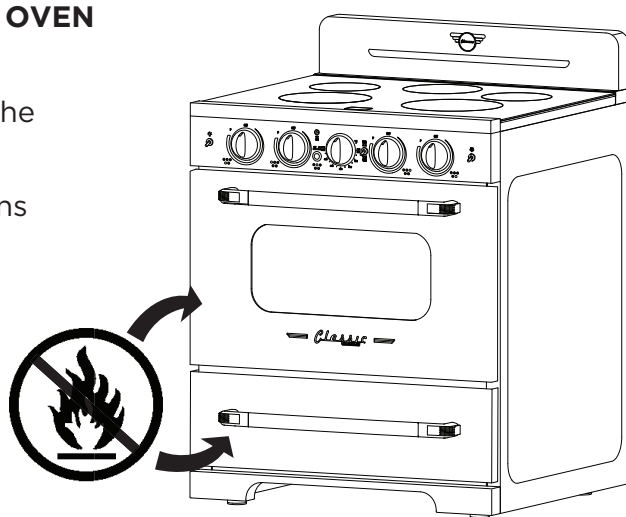

REMOVING THE KICKPLATE FOR CLEANING

For better access when cleaning underneath the range, remove the magnetic kickplate at the bottom of the range by pulling it forward.

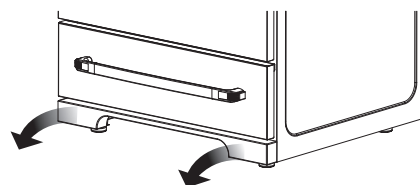

CAUTION

Do not place heavy objects on the open oven door



CAUTION

DO NOT PULL THE OVEN HANDLE TO THE LEFT OR RIGHT WITH FORCE DURING INSTALLATION.

DO NOT USE THE OPEN OVEN DOOR TO MOVE OR POSITION THE APPLIANCE.

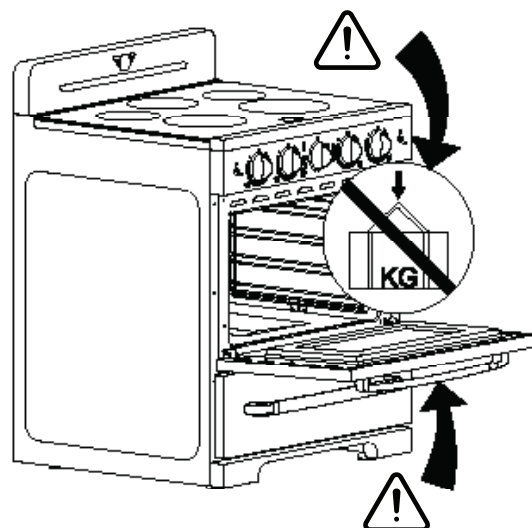

CARE & MAINTENANCE (continued)

REPAIR AND REPLACEMENT PARTS

When repair and/or replacement parts are needed, contact the dealer where the range was purchased. If your range was purchased from a source other than an appliance dealer, contact the manufacturer at the address shown in this manual.

MOISTURE

During the initial heat-up of your range, heat mixing with the cooler air in the oven cavity may produce fogging of the door glass or a collection of water on the door. To prevent this, open the oven door for the first few seconds of initial oven heat-up. This will allow the moist air within the oven to escape, without the forming of visible moisture on the range. The amount of moisture will depend upon the humidity of the air and water content of the food being cooked. Fogging and/or dripping water can occur in geographic locations of high humidity.

TROUBLESHOOTING

Many common appliance problems can be solved by following the suggestions below.

PROBLEM	POSSIBLE CAUSE/SOLUTIONS
The cooktop makes faint clicking sounds during operation	<ul style="list-style-type: none">• This is a normal sound of the electronic switches that maintain cooking temperature
The cooktop makes a loud humming noise	<ul style="list-style-type: none">• Improper cookware can cause loud humming noises of up to 63 dB• Ensure you are using induction compatible cookware
The cooktop makes a low humming noise when more than 2 elements are being used simultanelously	<ul style="list-style-type: none">• This is a normal noise due to interacting magnetic fields This humming is most noticeable when the elements are set to high• Raise or lower the power level settings of one or all of the elements to reduce/eliminate noise• Ensure that pots/pans make complete contact with surface and fully cover the element ring
Surface units will not maintain a rolling boil or frying rate is not fast enough	<ul style="list-style-type: none">• Bottom of pan is not making adequate contact with cooktop Use heavy-weight pans that have flat bottoms• Use appropriate induction-ready cookware - the size of the pan bottom should match the diameter of the surface unit selected
Foods cook slowly or not at all	<ul style="list-style-type: none">• Improper cookware being used - use induction compatible cookware

TROUBLESHOOTING (continued)

PROBLEM	POSSIBLE CAUSE/SOLUTIONS
Surface units do not operate.	<ul style="list-style-type: none"> • You have blown a household fuse or tripped a circuit breaker • The surface units are not plugged in correctly • You have not set the element control correctly
Control knobs will not turn	<ul style="list-style-type: none"> • For cooktop control knobs, be sure to push them in before turning • For oven control knobs, be sure to turn the knob in the right direction
Oven light does not work	<ul style="list-style-type: none"> • Light bulb is loose or defective - check and replace if necessary • The oven light switch is broken - contact Unique's technical service department for instructions
Oven does not work.	<ul style="list-style-type: none"> • Ensure that the rocker switch is set to OVEN • You have blown a household fuse or tripped a circuit breaker • You have not set the control knobs correctly
Broil does not work	<ul style="list-style-type: none"> • Ensure that the rocker switch is set to BROIL • You have blown a household fuse or tripped a circuit breaker
Food does not broil properly	<ul style="list-style-type: none"> • The oven control switch is not set to BROIL • Improper rack position being used - check and reposition if needed • Ensure that cookware is suitable for broiling • Oven thermostat is defective - contact Unique's technical service department for instructions
Food does not bake properly	<ul style="list-style-type: none"> • The oven control knob is not set properly • Rack position is incorrect - check and reposition if needed • Improper cookware is being used - replace if necessary • Oven thermostat is defective - contact Unique's technical service department for instructions

ERROR CODES

ERROR CATEGORY	ERROR CODE DISPLAYED				REPAIR STATUS	
	A digital tube	B digital tube	C digital tube	D digital tube		
Power board failure or communication error	F1				NOT RECOVERABLE	
	Left Module		Right Module			
Line coil NTC failure	F3					
	Left Module		Right Module			
IGBT NTC failure	F4					
	Left Module		Right Module			
NTC overheating of wire coil	E1					RECOVERABLE
	Left Module		Right Module			
IGBT overheating	E2					
	Left Module		Right Module			
High voltage protection	E3					
	Left Module		Right Module			
Under voltage protection	E4					
	Left Module		Right Module			
NTC line coil NTC removal protection	E5					
	Left Module		Right Module			
IGBT NTC removal protection	E6					
	Left Module		Right Module			

WIRING DIAGRAM

OVEN WIRING DIAGRAM / SCHÉMA DE CÂBLAGE DU FOUR

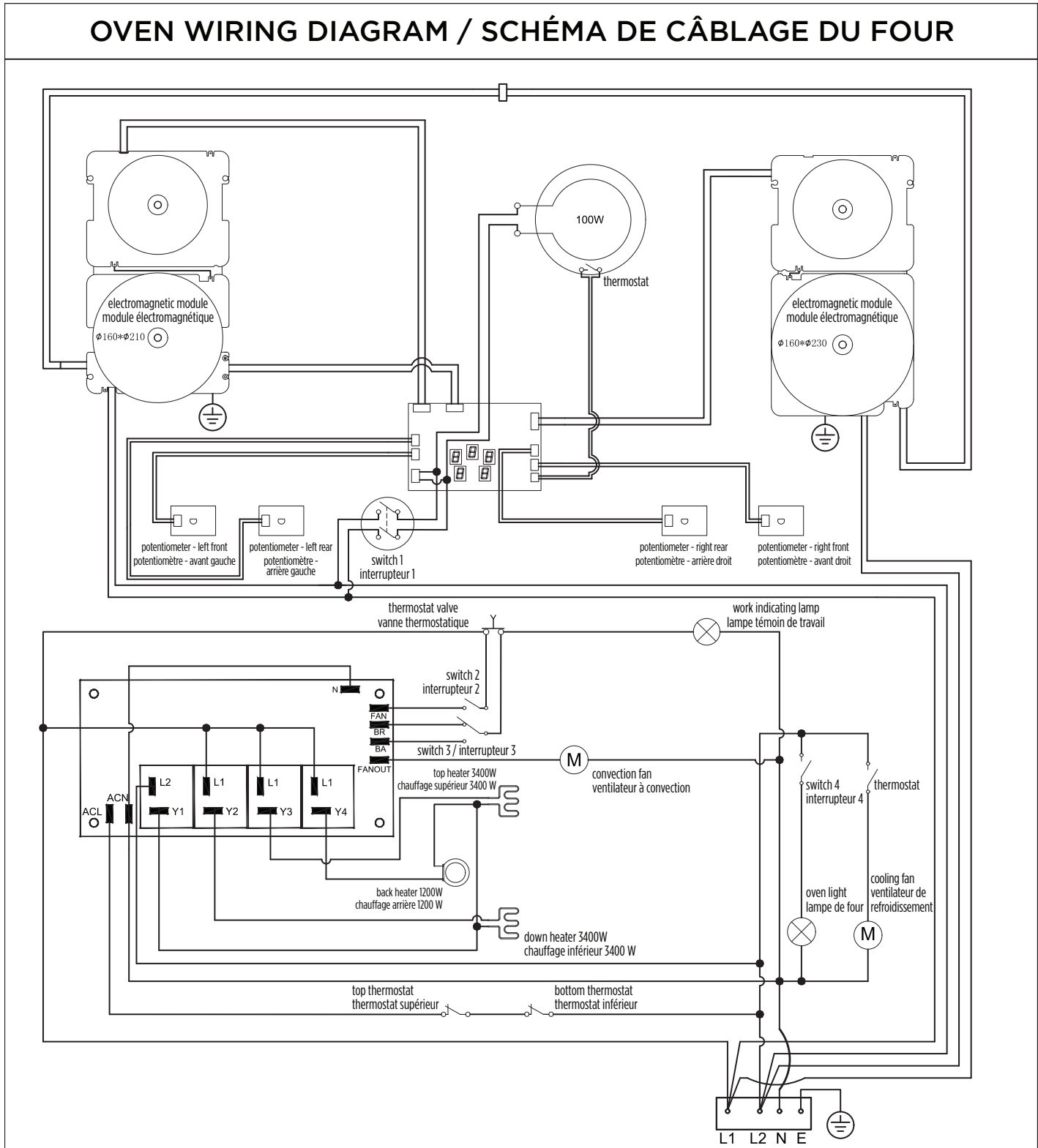

RATING LABEL

WARNING / AVERTIR

Do not store flammable materials inside this drawer
Ne Pas entreposer de matériaux inflammables à L'Intérieur
de ce tiroir

UNIQUE[®]

APPLIANCES



MODEL: UNQ-30CR IC

RATED VOLTAGE: 120/240V

RATED POWER: 12kW

RATED FREQUENCY: 60Hz

Right front:240V 2300W/P3700W

Left front:240V 2300W/P2600W

Rear left:240V 1200W/P1800W

Rear right:240V 1200W/P1800W

Rear Middle:240V 100W

Intertek
5010059

Intertek
EP 5024195

Oven Electric Heating Element:

Top Heater Power:240V 3400W

Back Heater Power:240V 1200W

Down Heater Power:240V 3400W

Oven Light :120V 25W

Oven Fan:120V 38W

Cooling Fan:120V 34W

© Unique Appliances Ltd. All rights reserved.
Designed and manufactured for: Unique Appliances Ltd.
2245 Wycroft Road #5, Oakville, Ontario, Canada, L6L 5L7
© Unique Appliances Ltd. Tous droits réservés.
Conçu et fabriqué pour: Unique Appliances Ltd.
2245 Wycroft Road #5, Oakville, Ontario, Canada, L6L 5L7

www.UniqueAppliances.com

CONFORMS WITH UL STD. 858
CERTIFIED TO CSA STD C22.2 NO.61
EN CONFORMITÉ AVEC UL STD. 858
CERTIFIÉS CSA STD C22.2 NO.61

MADE IN CHINA
FABRIQUÉ EN CHINE

WARRANTY

Unique Appliances Ltd. (hereafter “Unique”) warrants that this UNIQUE appliance is free from manufacturer’s defects in material and workmanship under normal usage and service under the following terms.



Parts Warranty

This appliance has been designed for domestic household use. If properly installed, adjusted and operated under normal conditions in accordance with printed instructions, it will satisfactorily perform the functions that are generally expected of this type of appliance.

If the appliance fails to do so because of a defect in material or workmanship within **one year** from the original date of purchase: Unique will at our option, repair, exchange, or correct by other means Unique consider appropriate, any part(s) Unique finds to be defective except for the surface finish.

Ownership

This Warranty is made only to the first purchaser (“original purchaser”) who acquires this appliance for his/her own use and will be honored by Unique Appliances and by the Seller. Purchaser must retain their receipt as proof of purchase date.

Warranty Conditions

This warranty does not apply to any appliance that has been subjected to alterations, misuse, abuse (including damage by foreign agents or chemicals), accident, improper installation or service, delivery damage, or other than normal household use and service. This UNIQUE appliance must be serviced regularly as outlined in the Owner’s Manual. In case of damage, the owner must provide proof of purchase, Model, and Serial Number to the selling dealer or Unique Appliances. This warranty is LIMITED STRICTLY to the terms indicated herein, and no other expressed warranties or remedies thereunder shall be binding on Unique.

Purchaser’s Responsibilities

The purchaser will be responsible for the costs of any service calls requested to demonstrate or confirm the proper operation of the appliance, the installation, or to correct malfunctions in the appearance created by the operation of the appliance in a manner not prescribed by or cautioned against in the use and care instructions.

Model and Serial Number

The appliance model number and serial number can be found on a rating plate on the range. The purchaser should always refer to the model and serial number when talking to or contacting the dealer from whom the appliance was purchased.

EXCLUSIONS

Save as herein provided, by Unique, there are no other warranties, conditions, representations or guarantees, express or implied, made or intended by Unique or its authorized distributors and all other warranties, conditions, representations or guarantees, including any warranties, conditions, representations or guarantees under any Sale of Goods Act or like legislation or statute is hereby expressly excluded. Save as herein provided, Unique shall not be responsible for any damages to persons or property, including the unit itself, howsoever caused or any consequential damages arising from the malfunction of the unit and by the purchase of the unit, the purchaser does hereby agree to indemnify and hold harmless Unique from any claim for damages to persons or property caused by the unit

Removal or disfigurement of the rating plate will void the warranty. The purchaser will be responsible for any expenses involved in making the range readily accessible for servicing. The purchaser will be responsible for any extra charges where the installation is in a remote location such as un-assumed roads, islands, areas known as cottage country, more than 75 km outside a metropolitan area, or where a technician is not available. Freight damage is not covered by this warranty.

GENERAL PROVISIONS

No warranty or insurance herein contained or set out shall apply when damage or repair is caused by any of the following:

- 1) Power failure.
- 2) Damage in transit or when moving the appliance.
- 3) Improper power supply such as low voltage, defective house wiring or inadequate fuses.
- 4) Accident, alteration, abuse or misuse of the appliance such as inadequate air circulation in the room or abnormal operating conditions (ie. extremely high or low room temperature).
- 5) Use for commercial or industrial purposes (ie. If the appliance is not installed in a domestic residence).
- 6) Fire, water damage, theft, war, riot, hostility, acts of God such as hurricanes, floods etc.
- 7) Service calls resulting in customer education.
- 8) Improper Installation (ie. building-in of a free standing appliance or using an appliance outdoors that is not approved for outdoor application, including but not limited to: garages, patios, porches or anywhere that is not properly insulated or climate controlled).

Proof of purchase date will be required for warranty claims; retain bills of sale. In the event that warranty service is required, present the proof of purchase to our authorized service depot.

Nothing within this warranty shall imply that Unique will be responsible or liable for any direct or indirect loss of foods caused by failure in operation.

Factory Assistance

If the purchaser is unable to locate an authorized dealer/service agent, or if the purchaser does not receive satisfaction from the dealer, they may contact Unique Appliances Customer Service directly at Toll Free 1-877-427-2266 or 905-827-6154.

APPLIANCE INFORMATION

APPLIANCE INFORMATION

(manual copy - keep with your records)

To make care and servicing of your appliance easy and efficient, please record the following information for future reference:

Model:

Serial Number:

Purchased From:

Date Purchased:

PRODUCT REGISTRATION



Scan the QR Code

or

Visit our website at <https://uniqueappliances.com/product-registration/> to register your product.

CONTACT US

For questions related to the operation, safety or the purchase of your appliances, please contact your dealer for more information. For general information, contact our customer service department:



Email

info@UniqueAppliances.com



Toll-free

1-877-427-2266 or 1-905-827-6154
(available during regular business hours, 8:30 am to 4:30 pm, EST.)



Website

www.uniqueappliances.com



©2024 Unique Appliances Ltd., 2245 Wycroft Road #5,
Oakville, Ontario, Canada, L6L 5L7

www.UniqueAppliances.com