

# ASSEMBLY INSTRUCTIONS

## MODERN DINING TABLE

ASSEMBLY  
REQUIREMENTS:

2-Person  
Assembly

Assembly Time  
(Approximate) 30 Minutes

Tools Required:  
(Not Provided)

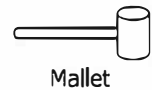

### Thank you for purchasing our product!

Please refer and use this assembly instruction to assemble the product. Contact our customer service department in case there are any missing or damage parts or hardware. Replacement parts are normally shipped within 2 or 3 days.

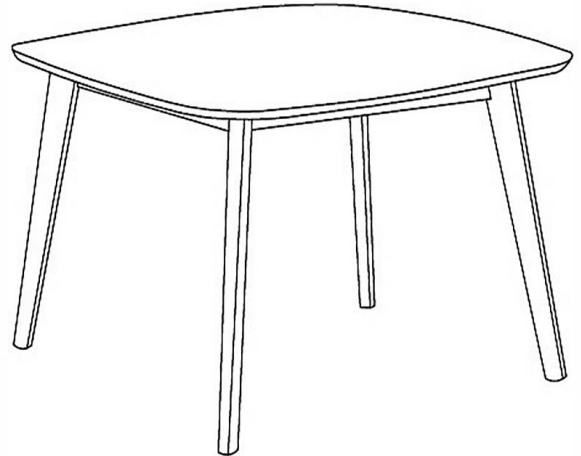

### ASSEMBLY PREPARATION

1. Remove all packaging materials, staples and packing straps from the carton.
2. Refer to Parts List and Hardware List, and ensure parts and hardware are complete before assembly.  
Contact customer service for missing parts.
3. Place all wooden parts on a clean, flat and soft surface ( e.g. carpet or rug) to prevent parts from getting scratched.

### SAFETY PRECAUTION:

1. KEEP ALL HARDWARE PARTS OUT OF REACH OF CHILDREN.
2. DISPOSE PLASTIC PACKAGING MATERIAL IMMEDIATELY TO AVOID ANY RISK OF SUFFOCATION TO CHILDREN AND ANIMALS.

### TIPS FOR ASSEMBLY:

1. Allow ample room for assembly and in close proximity to where product will be placed.
2. Assemble the product on a surface that does not scratch or damage the exterior gloss and finish of the furniture.
3. Check all of the parts and quantities are included before assembly.
4. Identify all of the parts, hardware and quantities required for each step.
5. During assembly, do not over-tighten any fittings as this may cause damage.
6. DO NOT USE POWER TOOLS TO ASSEMBLE THIS PRODUCT.
7. Always place the product on a flat, level surface.
8. Do not sit or stand on the partially assembled product; only use the product for which it is intended.

### CARE AND MAINTENANCE

- Use a slightly damp cloth to clean the product. Do not use bleach or abrasive cleaning material.
- Check all the fittings periodically and re-tighten as necessary. Do not use the product if any of the parts is damaged or broken.
- Never allow any kind of liquid to remain on your furniture. Absorption can cause wood to warp or delaminate.
- Do not place hot items (e.g. hot drinks) directly onto the wood surface.
- Do not drag and/or pull the furniture.





This product is for indoor and household use only - not for commercial use.

# ASSEMBLY INSTRUCTIONS MODERN DINING TABLE

Parts List (For 1 Table)

NO	COMPONENT	QTY
1	TABLE TOP WITH APRON	1
2	TABLE LEGS	4

Hardware List (For 1 Table)

NO	DESCRIPTION	QTY	Extra
A	JCBB BOLT M8 x 80mm 	8PCS	1PC
B	SPRING WASHER 	8PCS	1PC
C	FLAT WASHER 	8PCS	1PC
D	ALLEN KEY M5 	1PC	
E	LEG STUD 	4PCS	1PC

## ASSEMBLY STEPS

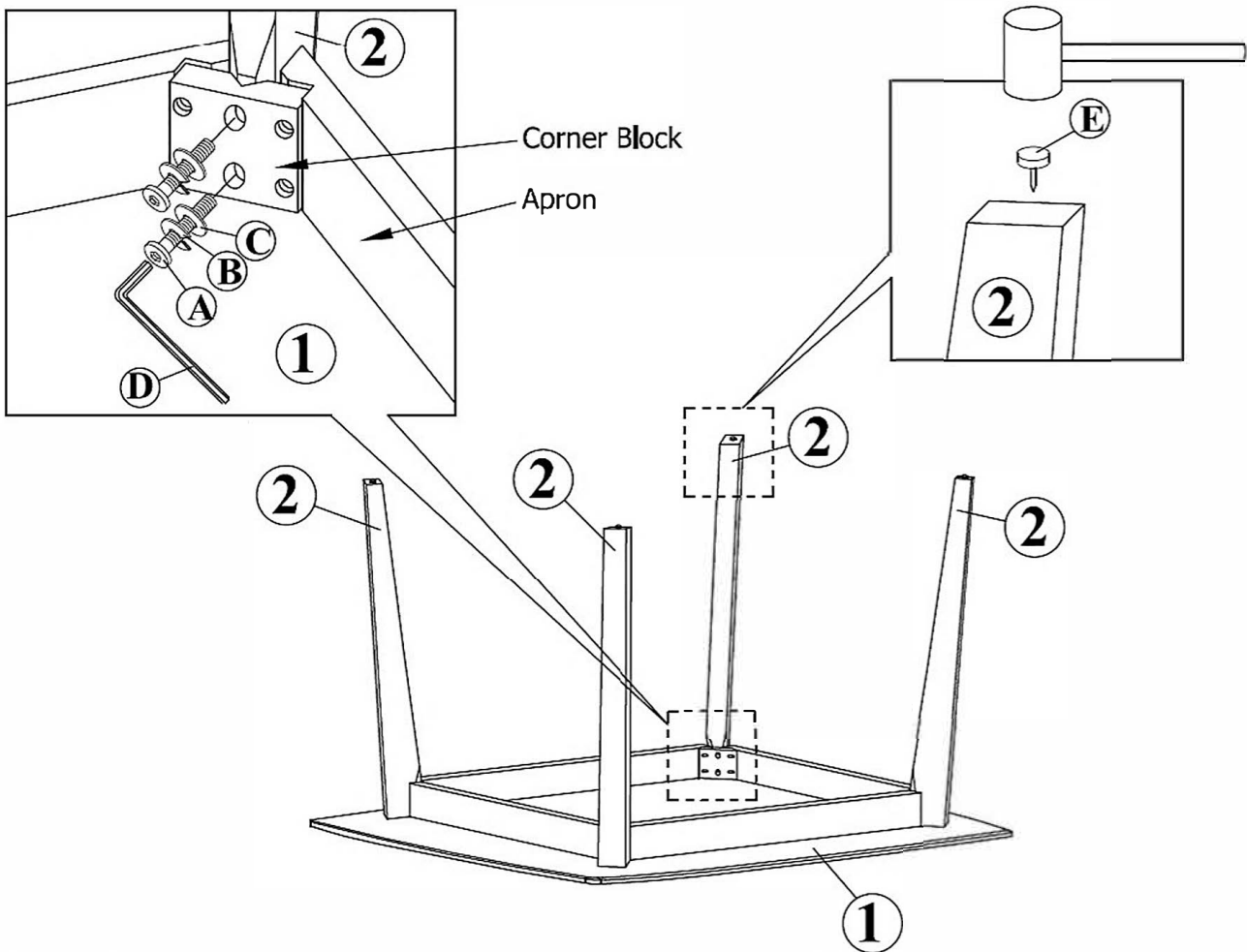

- With the assistance of another person, place Table Top (1) bottom-side up on a surface that does not scratch or damage the exterior gloss and finish.
- Position Table Leg (2) against the corners of the table aprons and align the screw holes on (2) to the screw holes on the corner block of the apron.
- Insert JCBC Screw (A) fitted with Spring Washer (B) and Flat Washer (C) into each hole. Use Allen Key (D) to drive (A) to fasten Table Leg (2) to corner block. Do not tighten (A) completely until both screws are in place on each leg. Do not over-tighten.
- Repeat the above assembly procedures b) & c) for the other three legs.
- Use a mallet or hammer to gently nail Leg Stud (E) into each end of the leg.
- With assistance, set the table right-side-up.

The assembly of the table is complete.