

# ASSEMBLY INSTRUCTION

SKU CODE : BW00471  
QUEEN SIZE PLATFORM BED

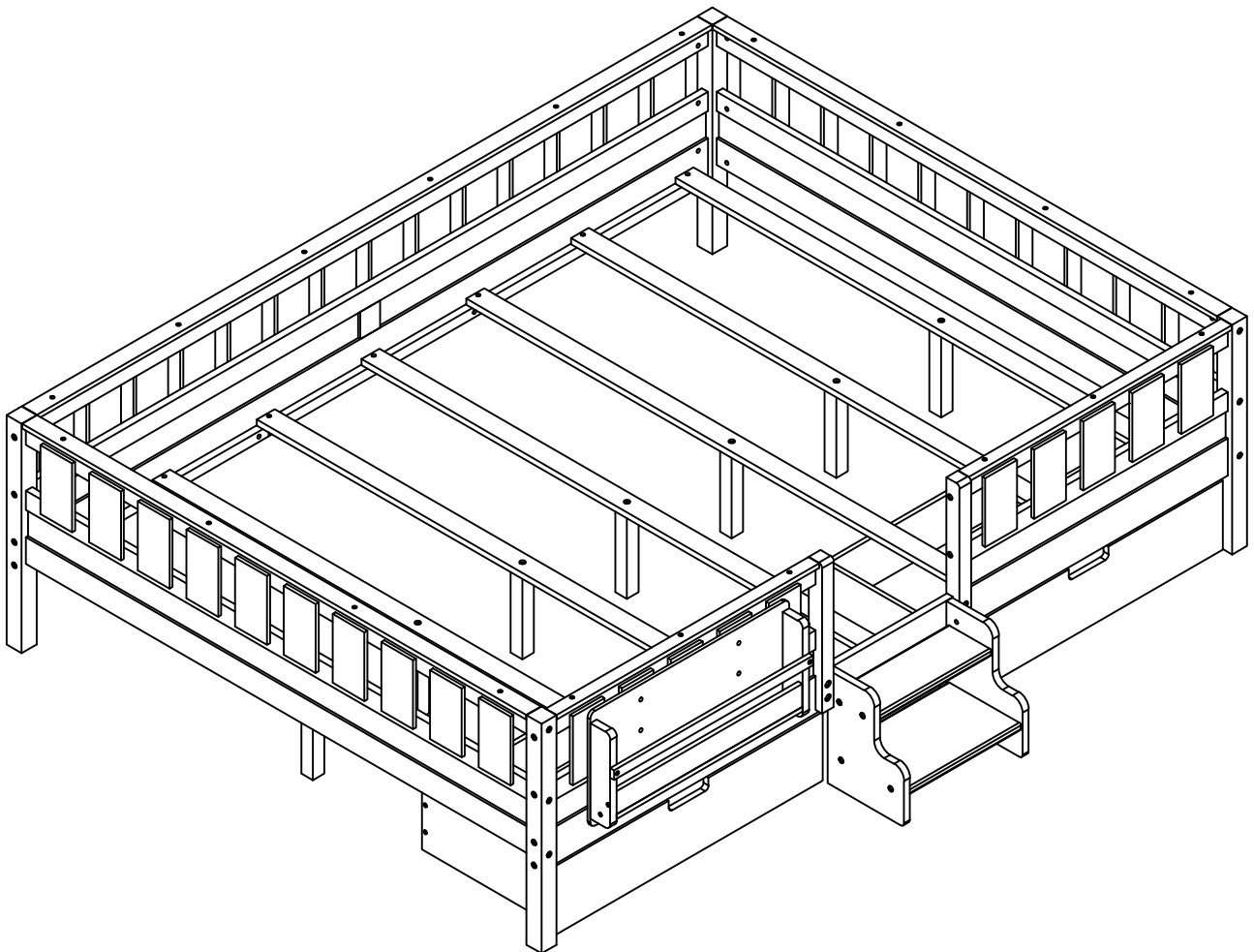

**Bed Type**  
**Queen Standard**

**Length**  
**80"**

**Width**  
**60 "**



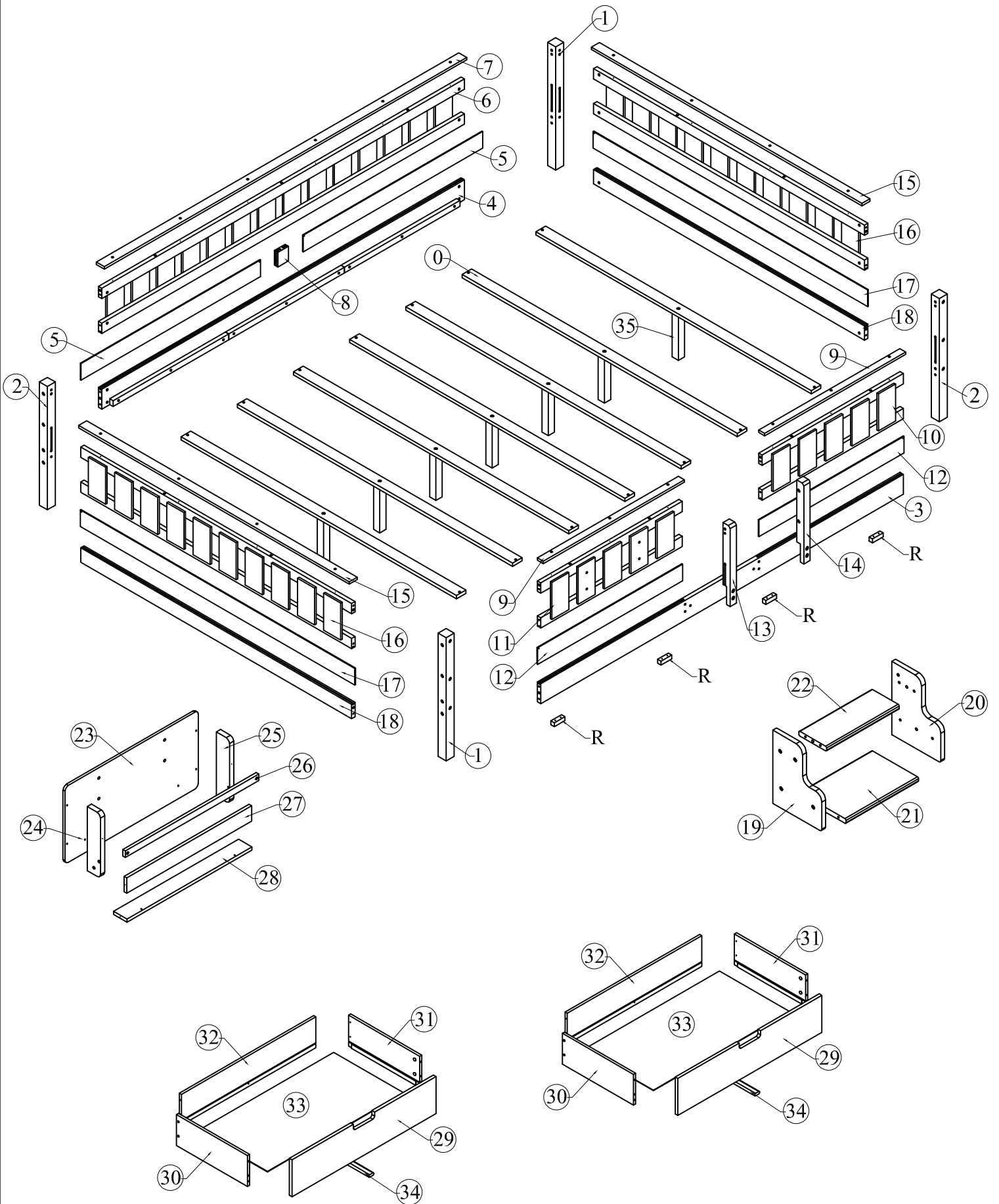

**Thickness**  
**6" max**

***This set is included 2 boxes, if don't receive full 2 boxes please contact our customer service team.***



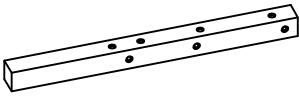
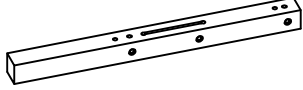
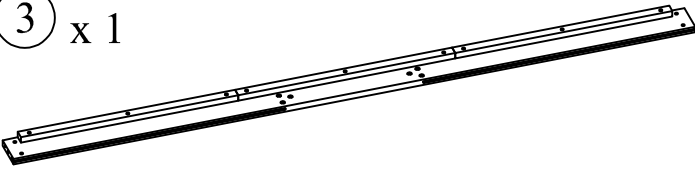
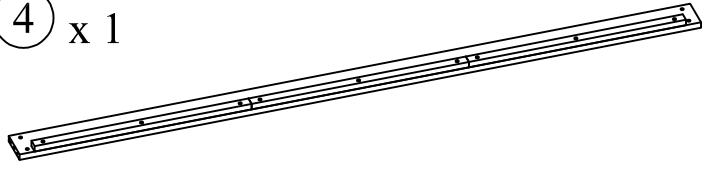
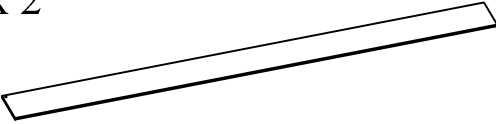
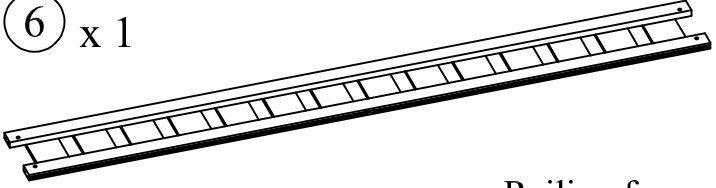
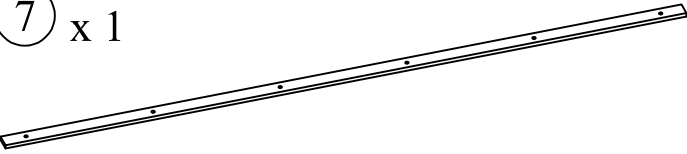
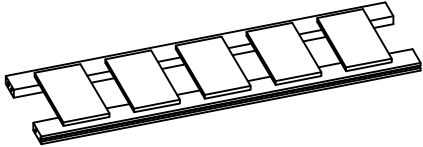
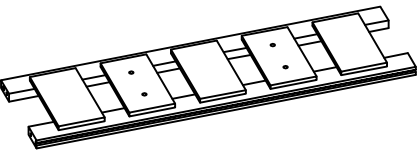
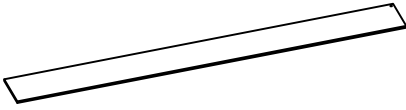

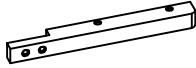
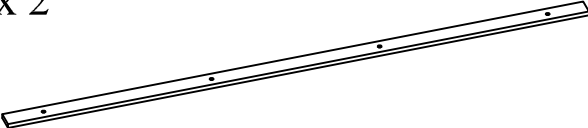
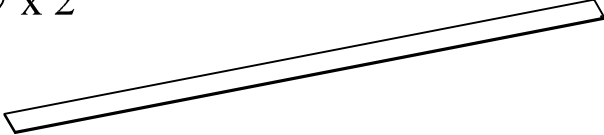
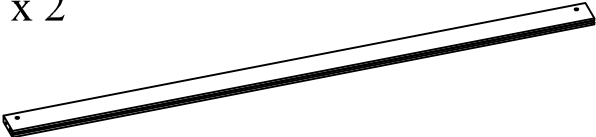





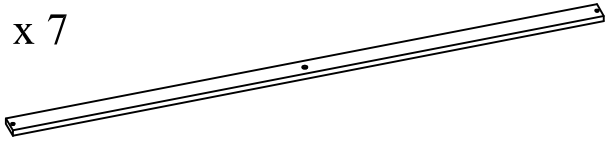

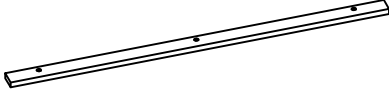
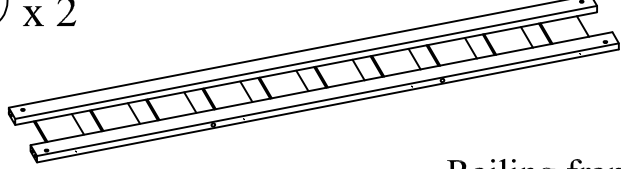
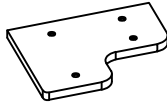
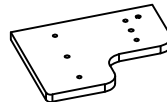
# ASSEMBLY INSTRUCTION

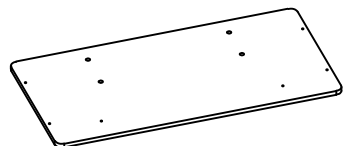

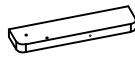

Part List ( Box 1 - BW00471-1 )

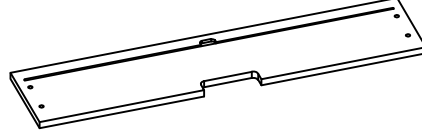
<p>① x 2</p>  <p>Leg</p>	<p>② x 2</p>  <p>Leg</p>
<p>③ x 1</p>  <p>Side rail</p>	<p>④ x 1</p>  <p>Side rail</p>
<p>⑤ x 2</p>  <p>Panel</p>	<p>⑥ x 1</p>  <p>Railing frame</p>
<p>⑦ x 1</p>  <p>Top cap</p>	<p>⑩ x 1</p>  <p>Railing frame</p>
<p>⑪ x 1</p>  <p>Railing frame</p>	<p>⑫ x 2</p>  <p>Panel</p>
<p>⑬ x 1</p>  <p>Vertical support</p>	<p>⑭ x 1</p>  <p>Vertical support</p>
<p>⑮ x 2</p>  <p>Top cap</p>	<p>⑰ x 2</p>  <p>Panel</p>
<p>⑱ x 2</p>  <p>Crossbar</p>	<p>⑳ x 1</p>  <p>Bottom Panel</p>





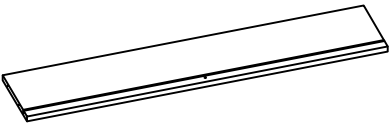
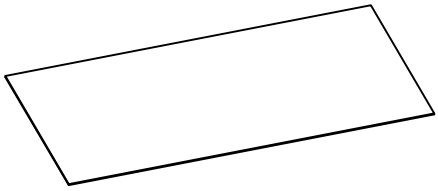





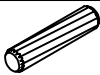







# Part List & Hardware List ( Box 2 - BW00471-2 )

<p>① x 7</p>  <p style="text-align: center;">Slats</p>	<p>⑧ x 1</p>  <p style="text-align: center;">Vertical guard rail</p>
<p>⑨ x 2</p>  <p style="text-align: center;">Top cap</p>	<p>⑯ x 2</p>  <p style="text-align: center;">Railing frame</p>
<p>⑰ x 1</p>  <p style="text-align: center;">Side Panel</p>	<p>⑳ x 1</p>  <p style="text-align: center;">Side Panel</p>
<p>㉒ x 1</p>  <p style="text-align: center;">Top Panel</p>	<p>㉓ x 1</p>  <p style="text-align: center;">Back Panel</p>
<p>㉔ x 1</p>  <p style="text-align: center;">Side Panel</p>	<p>㉕ x 1</p>  <p style="text-align: center;">Side Panel</p>
<p>㉖ x 1</p>  <p style="text-align: center;">Crossbar</p>	<p>㉗ x 1</p>  <p style="text-align: center;">Front Panel</p>
<p>㉘ x 1</p>  <p style="text-align: center;">Bottom Panel</p>	<p>㉙ x 2</p>  <p style="text-align: center;">Drawer Front</p>
<p>㉚ x 2</p>  <p style="text-align: center;">Drawer Sides</p>	<p>㉛ x 2</p>  <p style="text-align: center;">Drawer Sides</p>

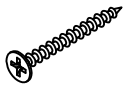
# Part List & Hardware List ( Box 2 - BW00471-2 )

<p>③② x 2</p>  <p>Drawer Back</p>	<p>③③ x 2</p>  <p>Drawer Bottom</p>
<p>③④ x 2</p>  <p>Bottom Support Rail</p>	<p>③⑤ x 7</p>  <p>Support Leg</p>

## Hardware List ( Box 2 - BW00471-2 )

No.	OUTLOOK	DESC	QTY
(A)		Dowel Ø10*40mm	37
(B)		Bolts 1/4"*15mm	04
(C)		Bolts 1/4"*25mm	04
(D)		Bolts 1/4"*35mm	07
(E)		Bolts 1/4"*60mm	10
(F)		Bolts 1/4"*80mm	04
(G)		Bolts 1/4"*90mm	28
(H)		Cross dowel 1/4"*13mm	42
(I)		Hex bolts 1/4"*15mm	08
(J)		Round Head Screw #8*25mm	06
(K)		Screws #6*12mm	36
(L)		Screws #8*30mm	42
(M)		Screws #8*35mm	18
(N)		Connecting Bolt	08
(O)		Base L	02
(P)		Wheels	08
(Q)		Allen key 60*22*4mm	02
(R)		Wood stop	04

ASSEMBLY TOOLS REQUIRED (NOT INCLUDED)



# STEP 1

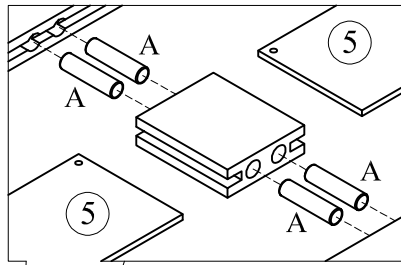
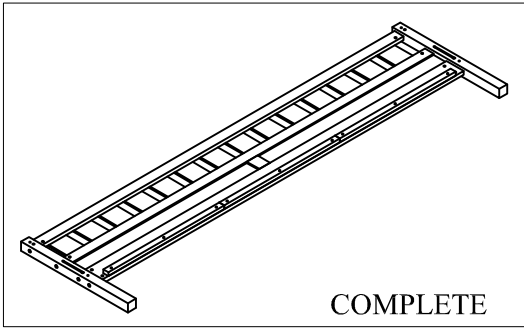

(A)		08
(G)		08
(H)		08

## STEP 1.1

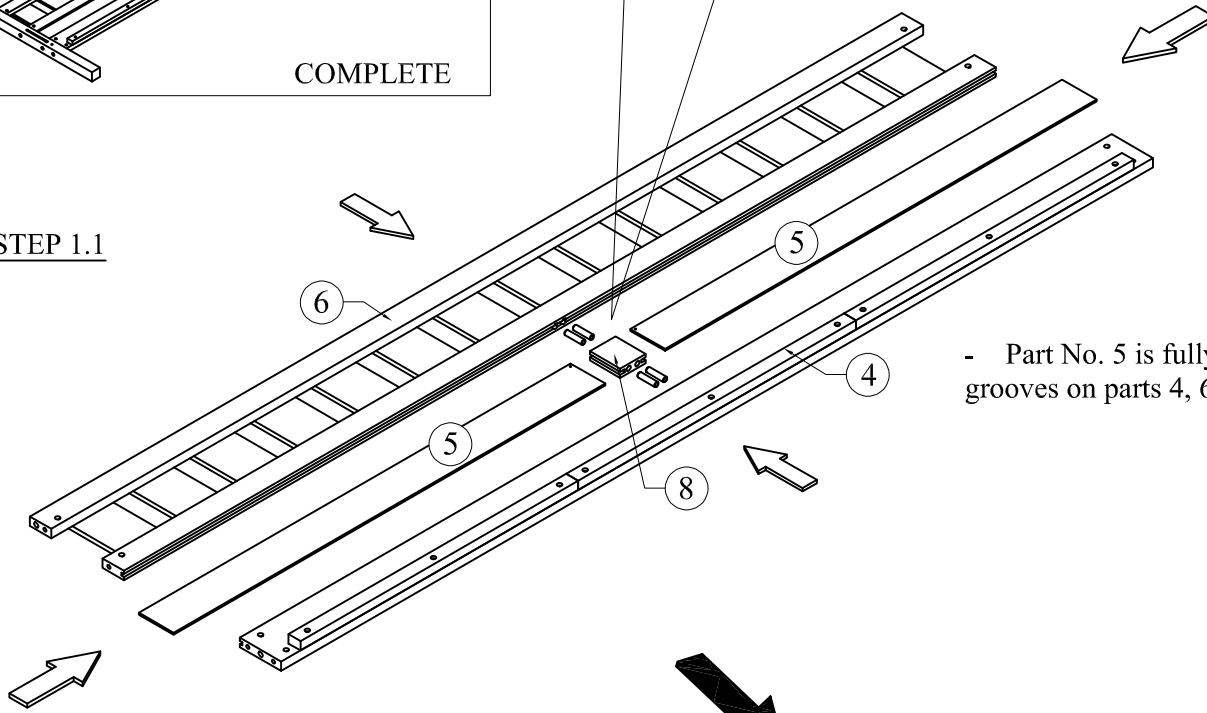

## STEP 1.1

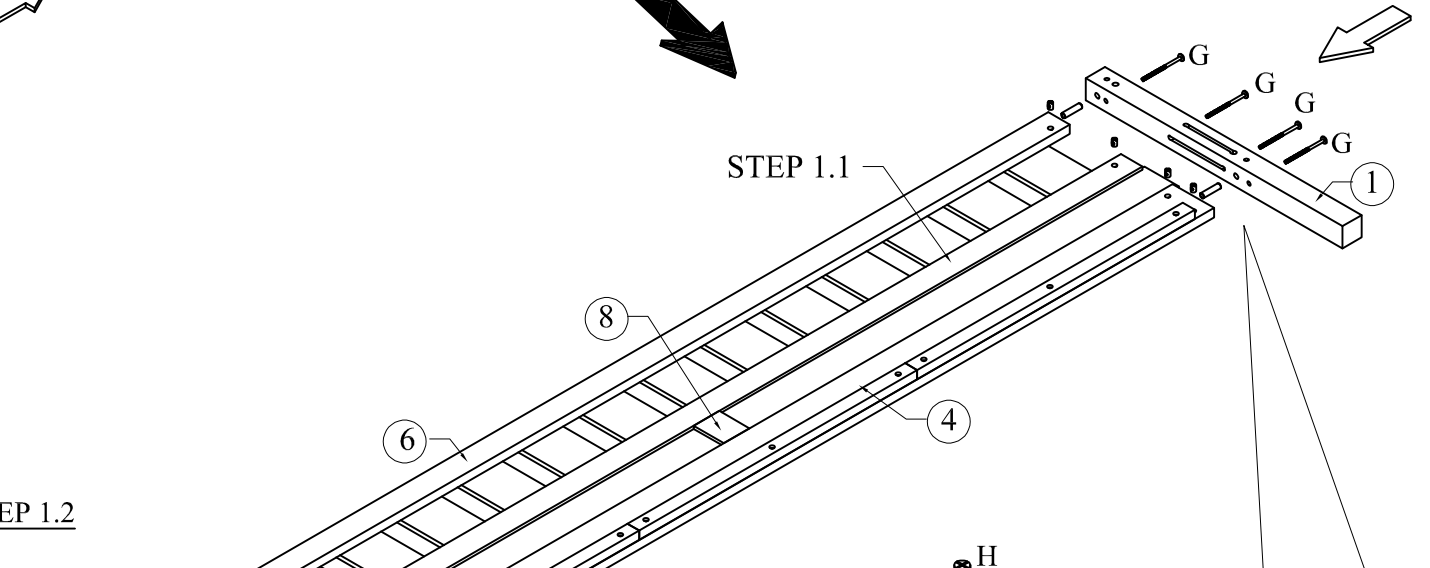

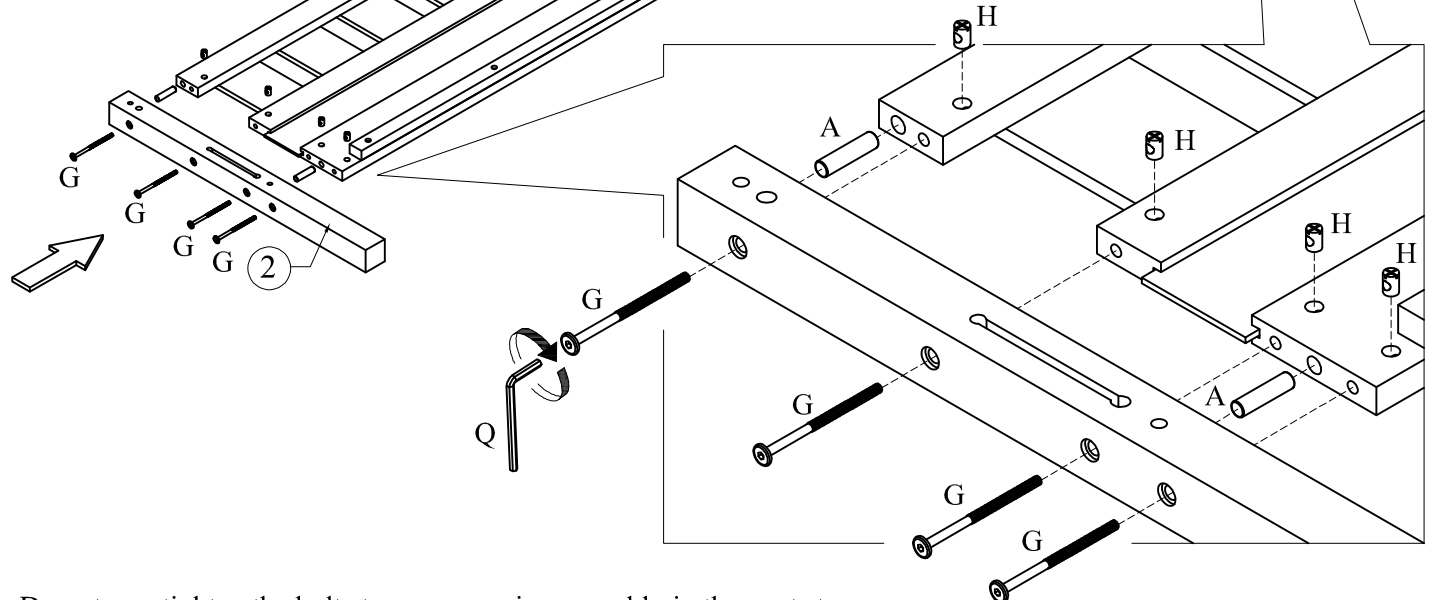

## STEP 1.2



Note: Do not overtighten the bolts to ensure easier assembly in the next step.

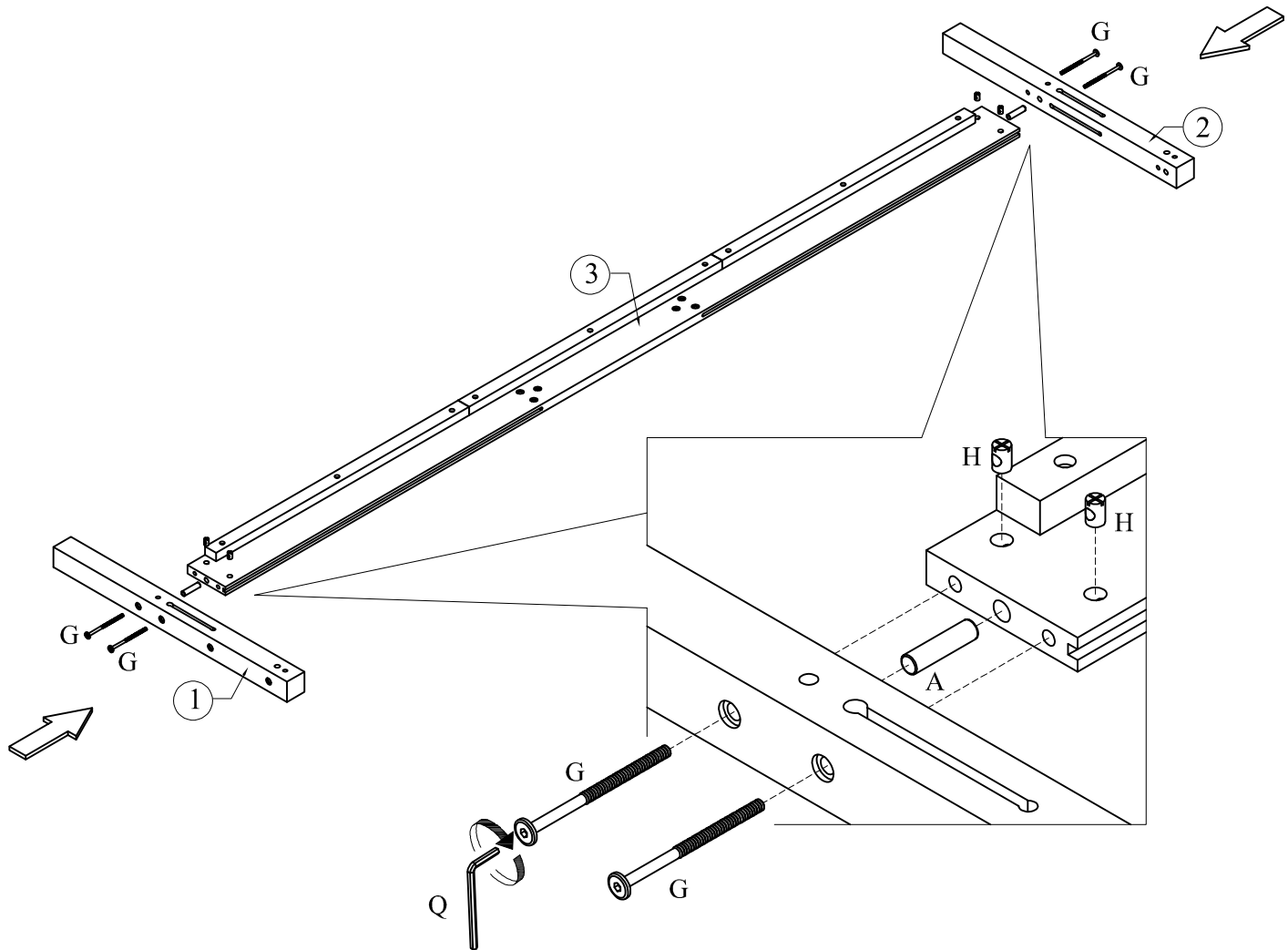
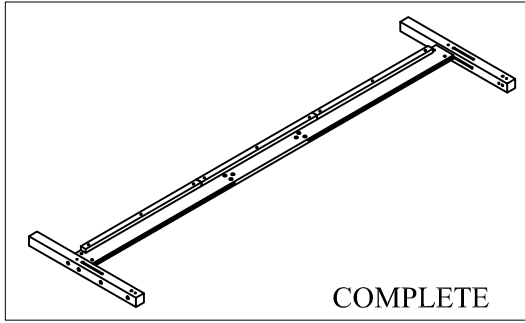

# STEP 2

(A)		02
(G)		04
(H)		04

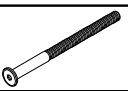

Note: Do not overtighten the bolts to ensure easier assembly in the next step.

# STEP 3

(A)		08
(G)		12
(H)		12

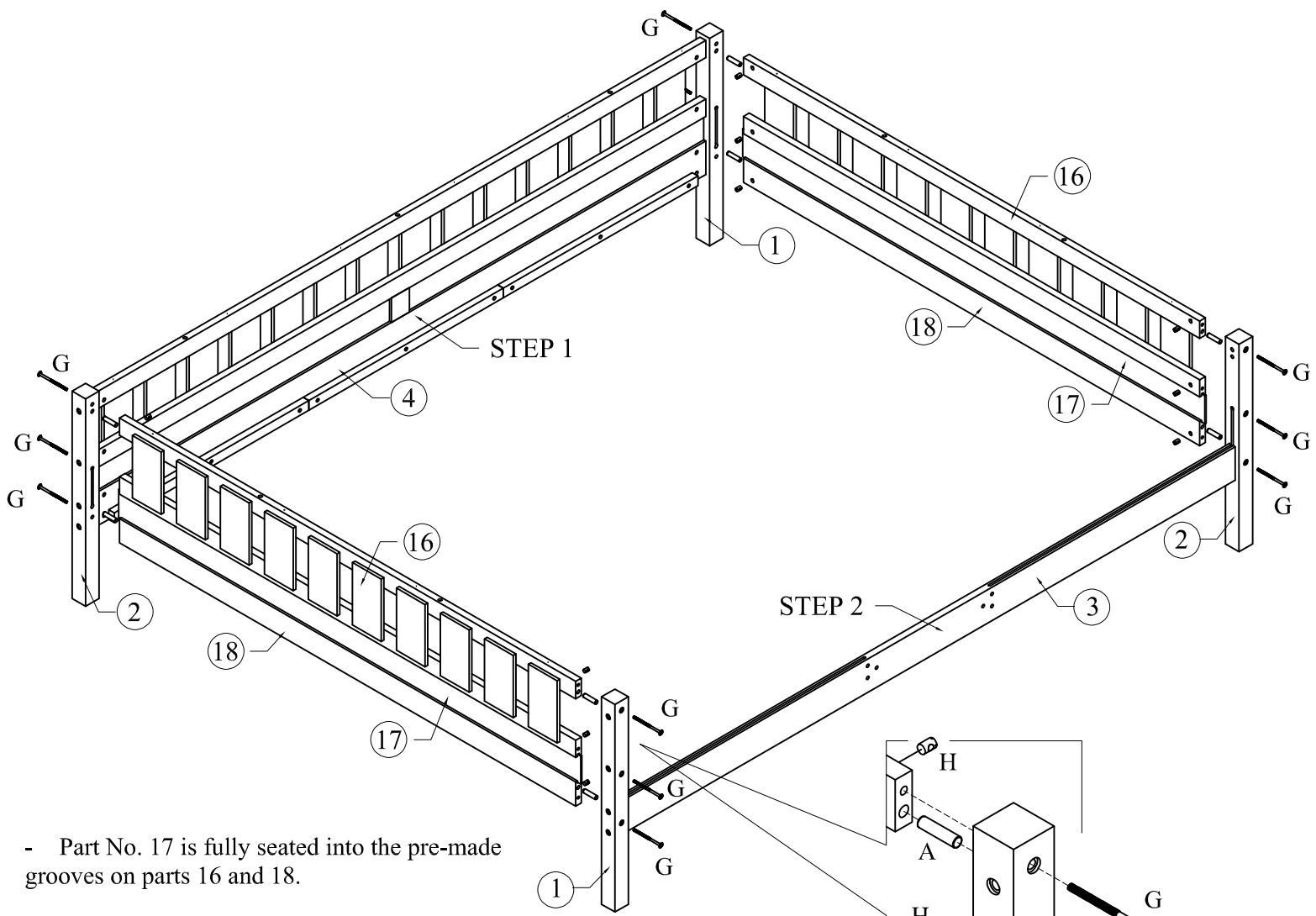
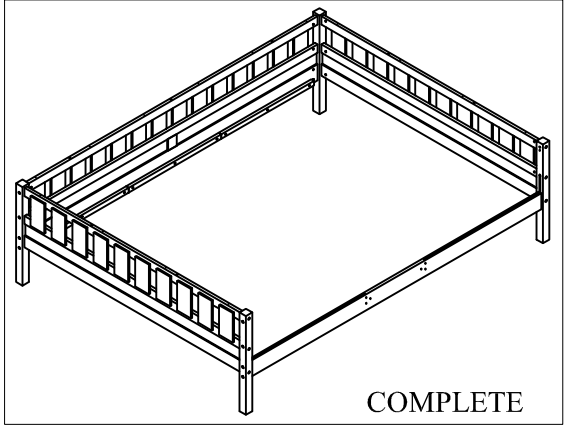

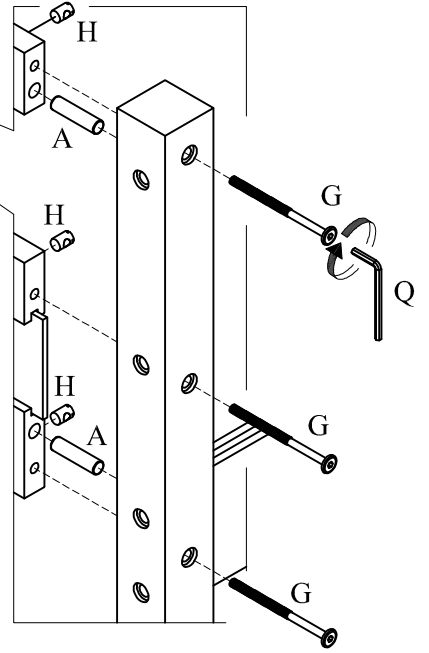

- Part No. 17 is fully seated into the pre-made grooves on parts 16 and 18.

Note: Do not overtighten the bolts to ensure easier assembly in the next step.



# STEP 4

(A)		07
(L)		14

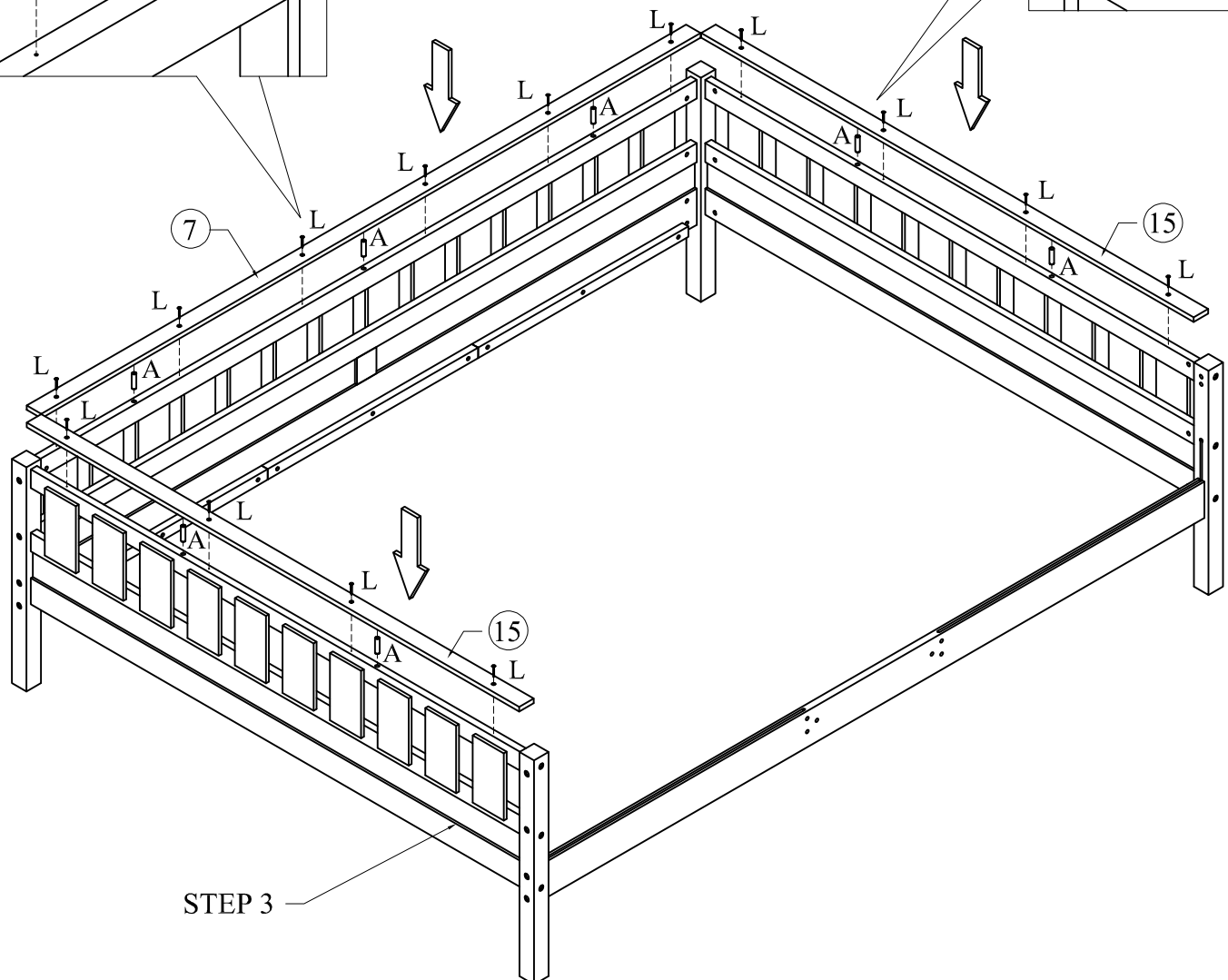
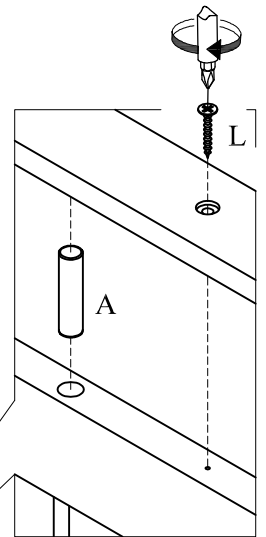
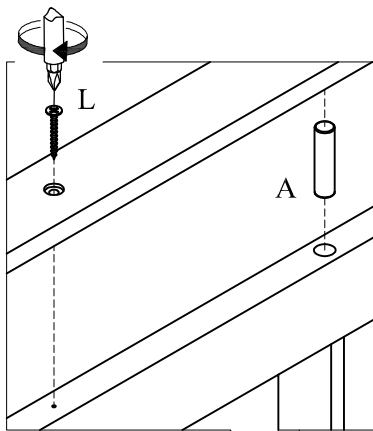
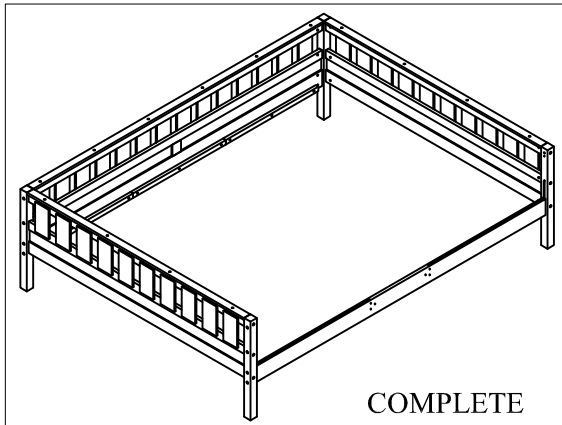

STEP 3

# STEP 5

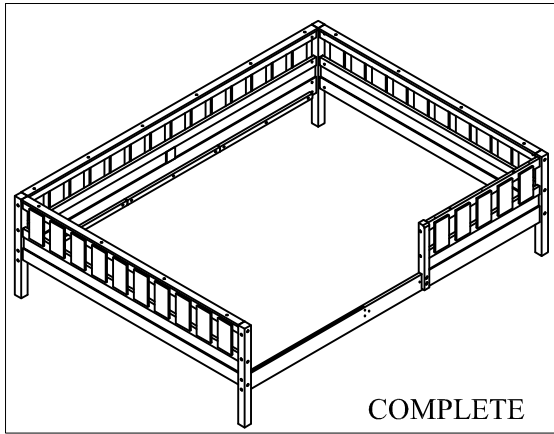

(A)		02
(F)		02
(G)		02
(H)		04

- Part No. 12 is fully seated into the pre-made grooves on parts 2, 3, 10 and 14.

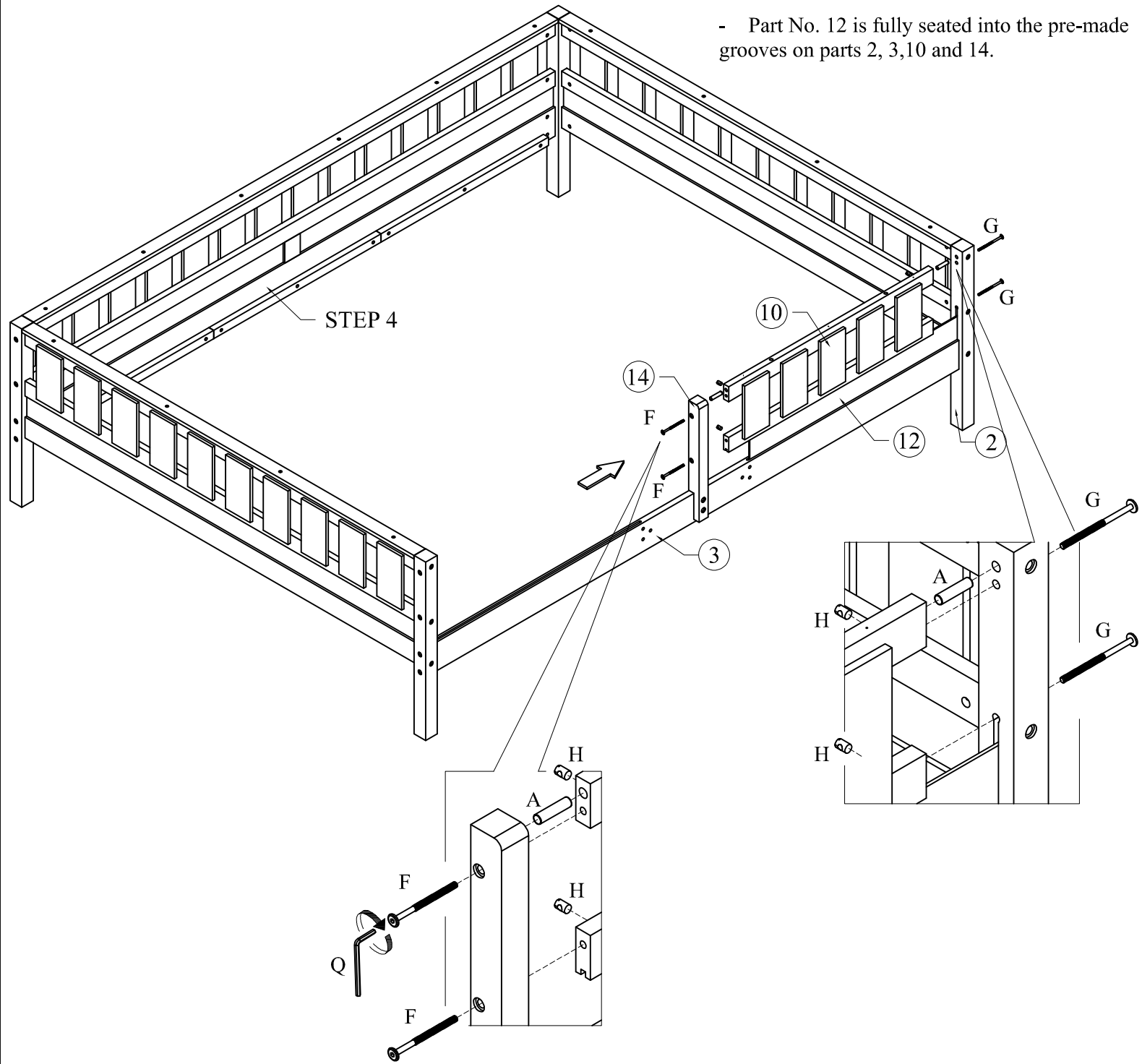

# STEP 6

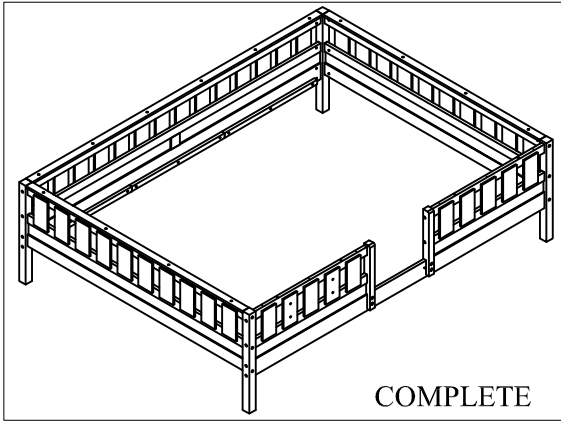

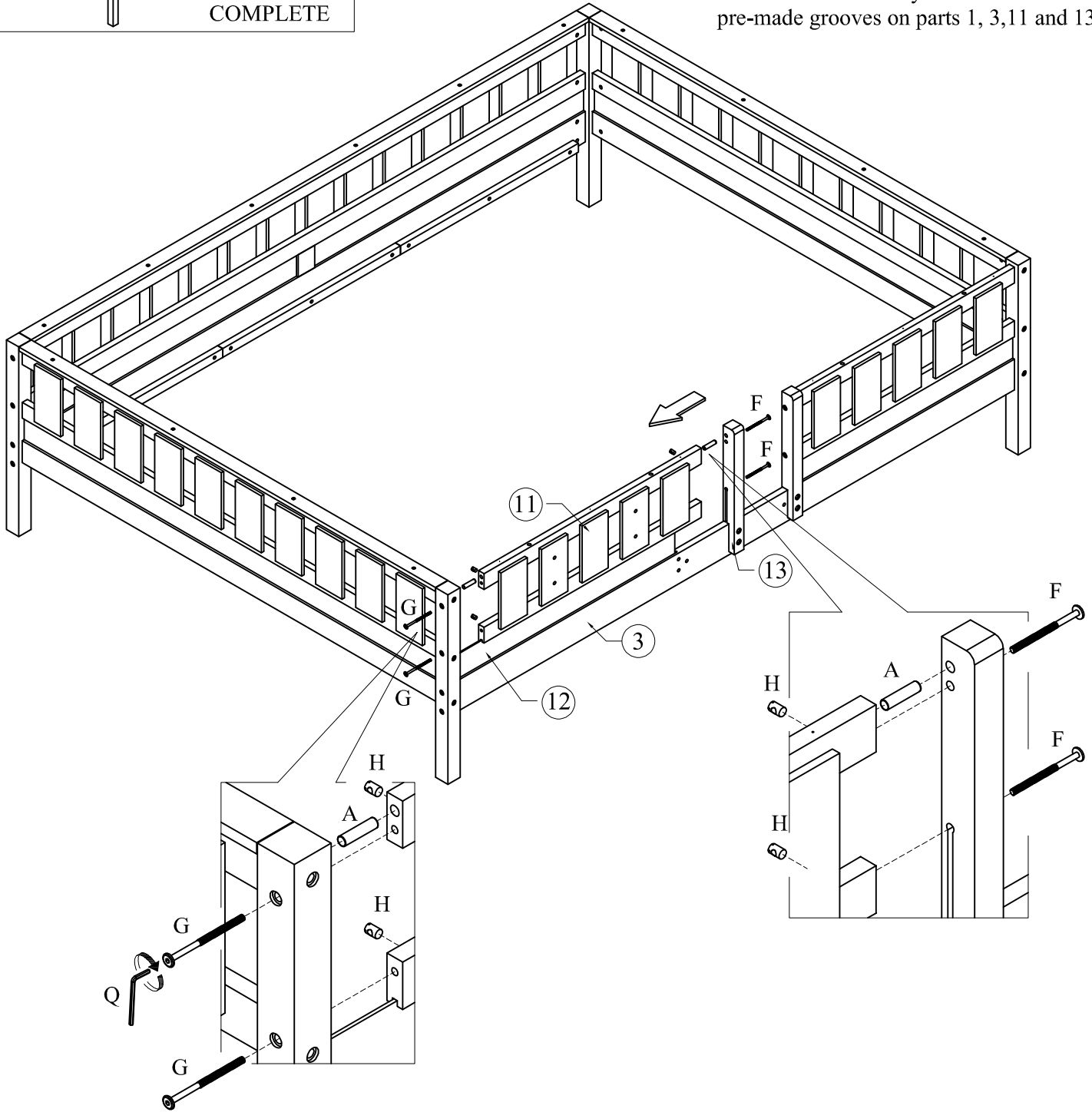

(A)		02
(F)		02
(G)		02
(H)		04

- Part No. 12 is fully seated into the pre-made grooves on parts 1, 3, 11 and 13.



# STEP 7

(C)		04
(I)		04

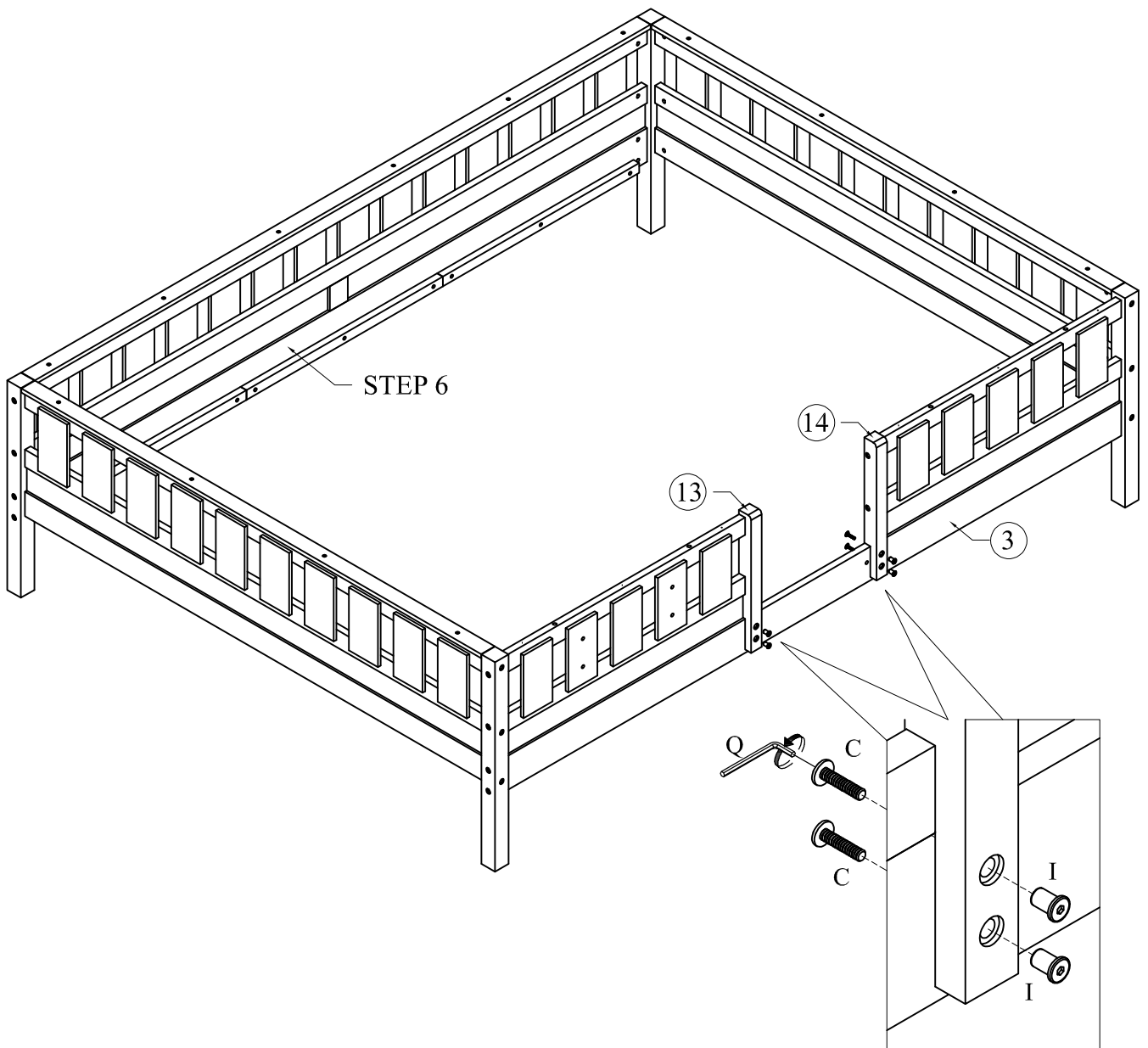
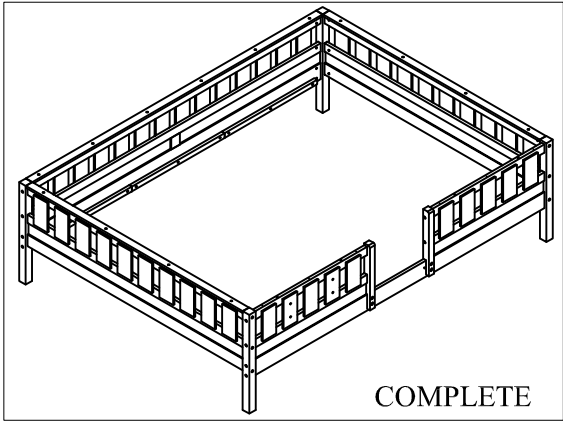



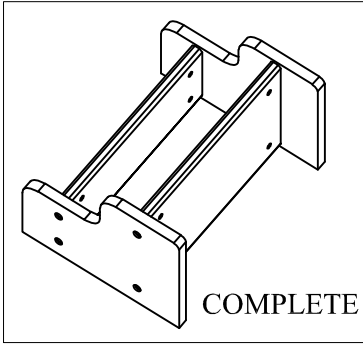

# STEP 9

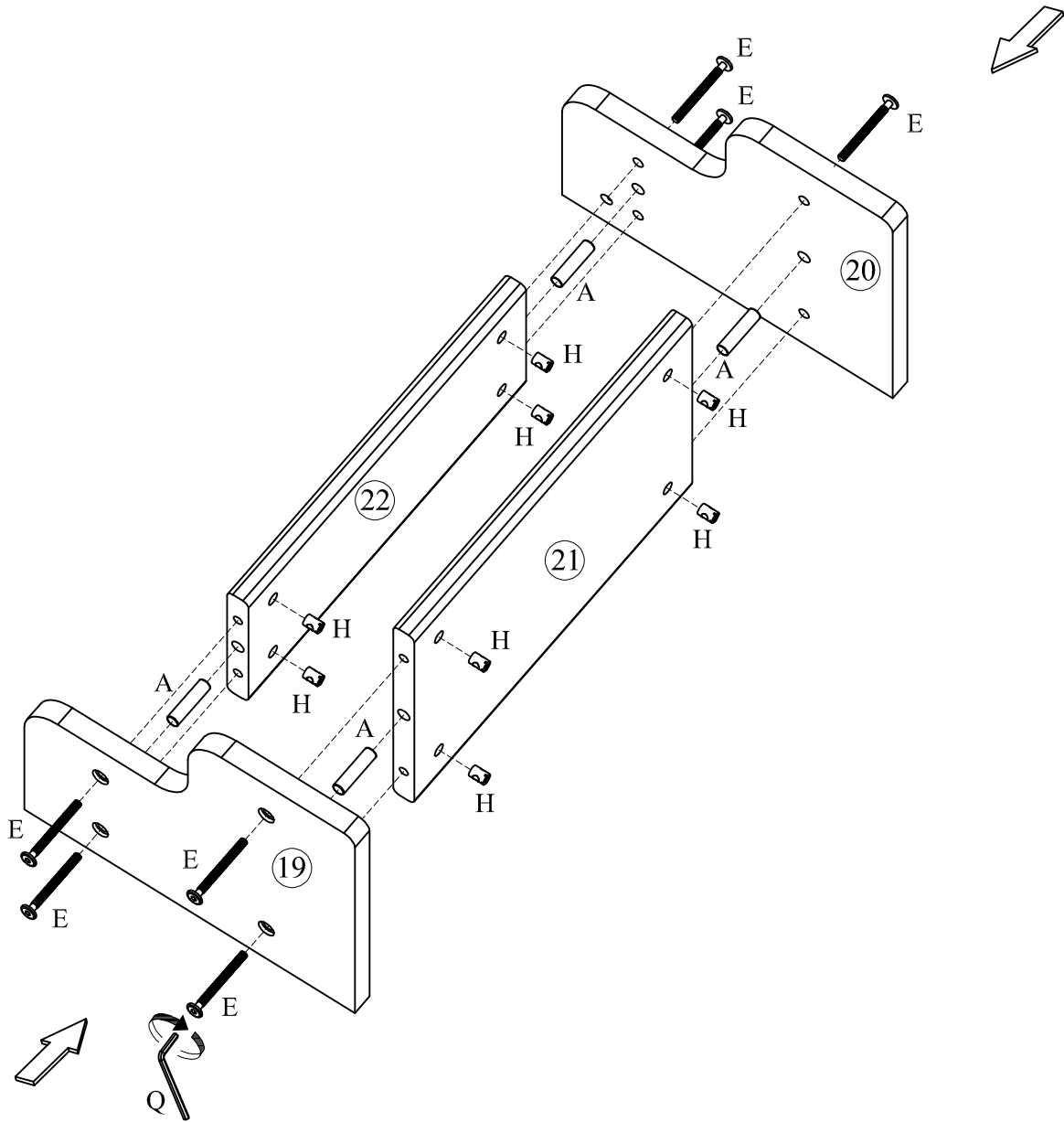

(A)		04
(E)		08
(H)		08



# STEP 10

(E)		02
(H)		02

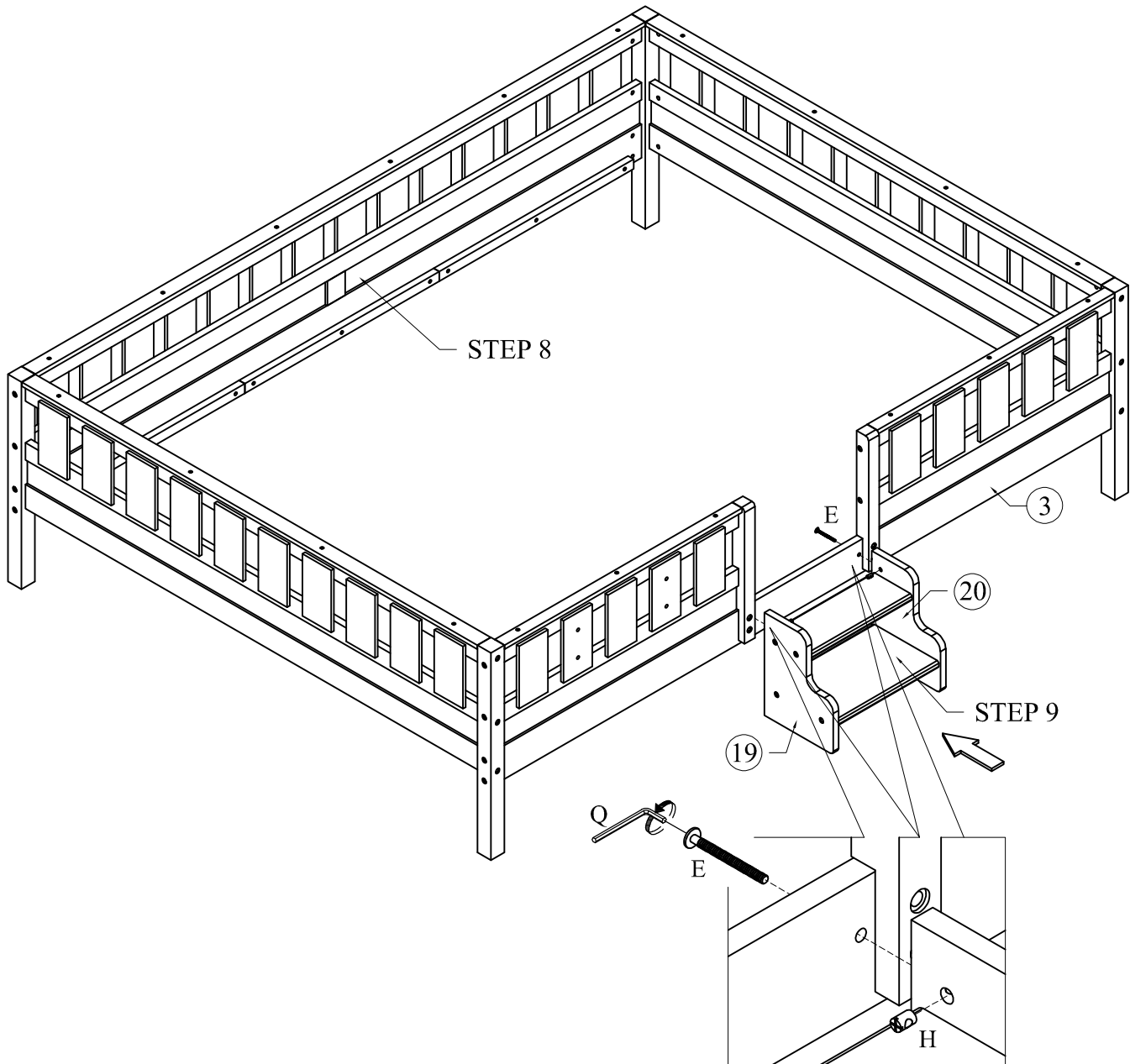
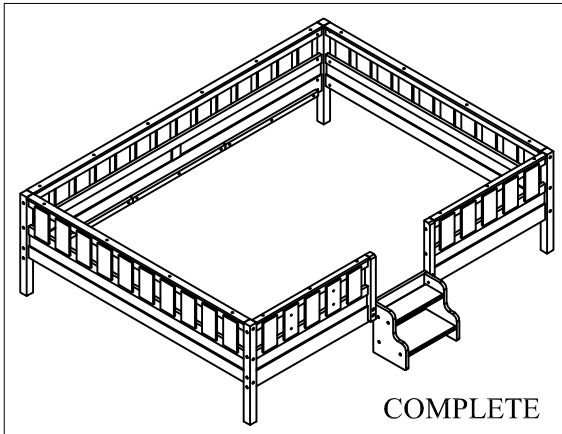

# STEP 11

(L)		06
-----	--	----

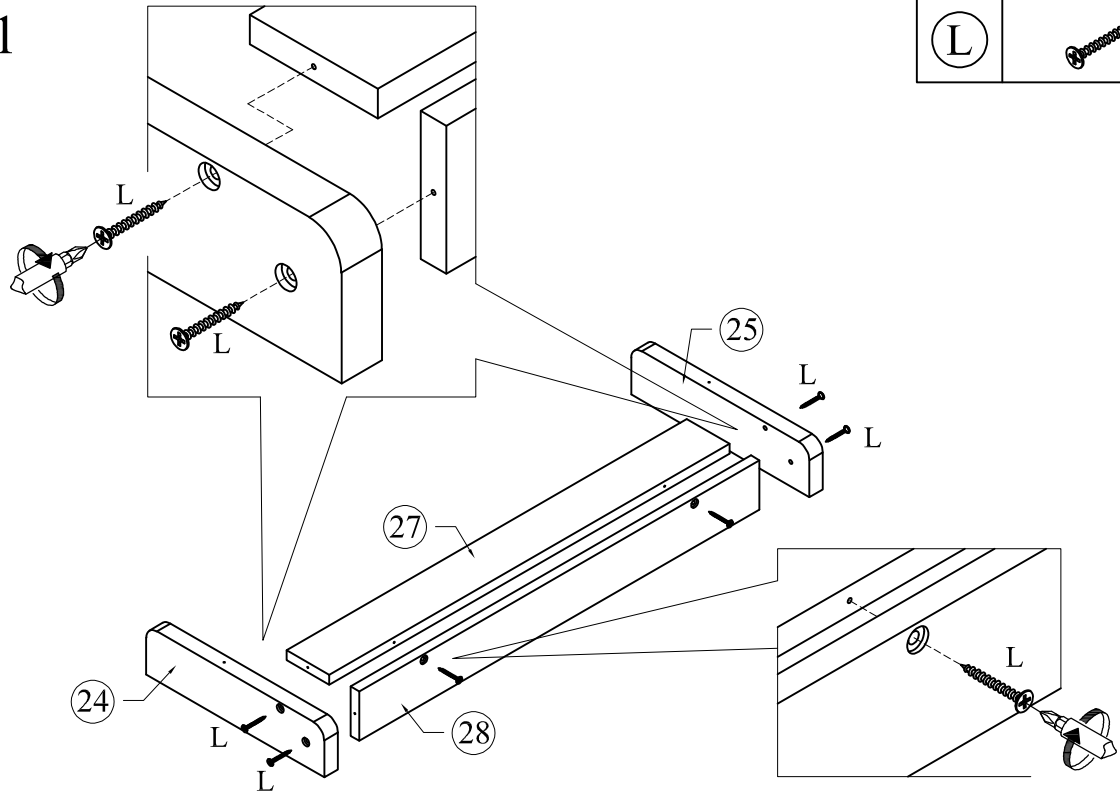

# STEP 12

(L)		02
-----	---	----

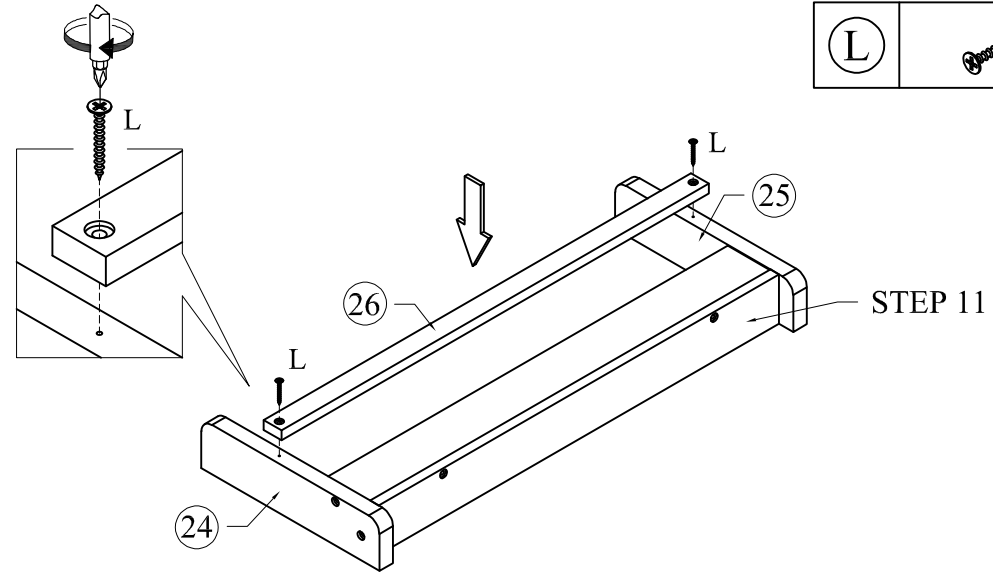



# STEP 13

Rotate the assembly from Step 12 as described and continue.

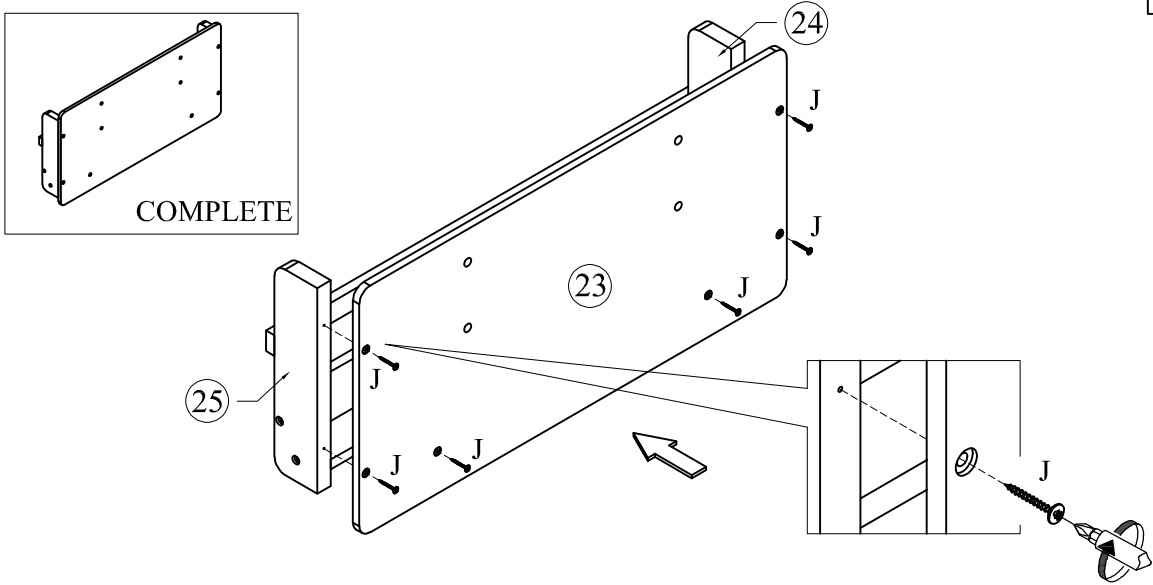
(J)		06
-----	---	----



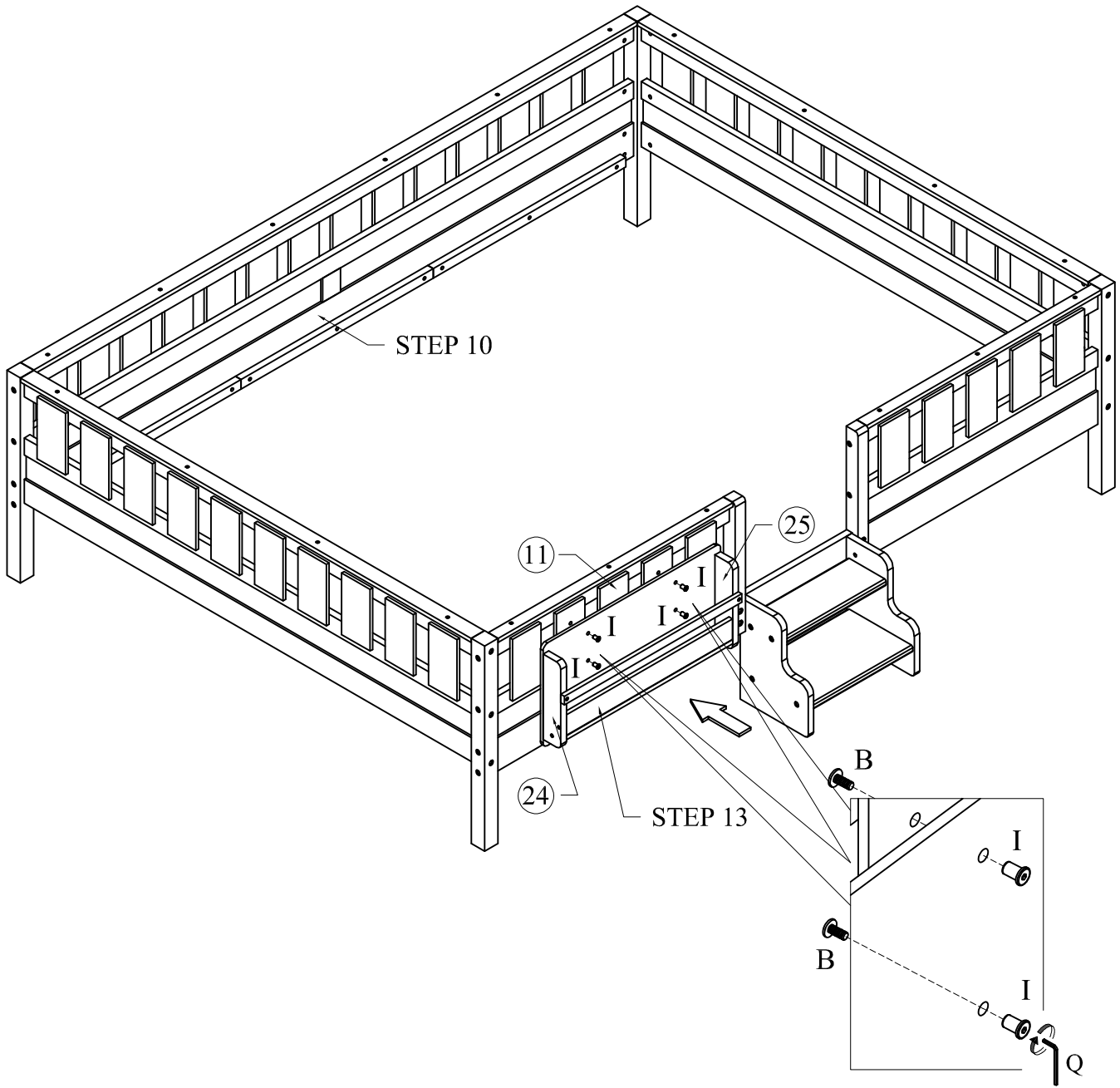
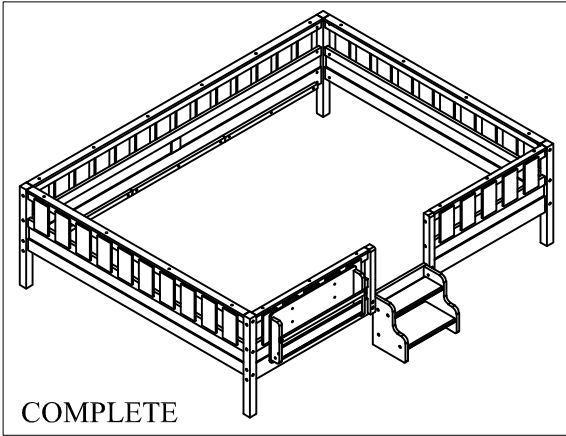

# STEP 14

(B)		04
(I)		04



# STEP 15

(D)		07
(L)		14

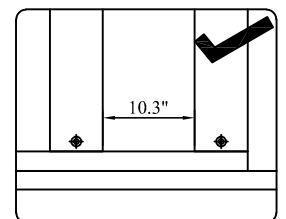
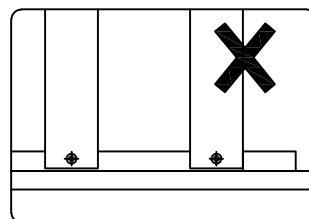
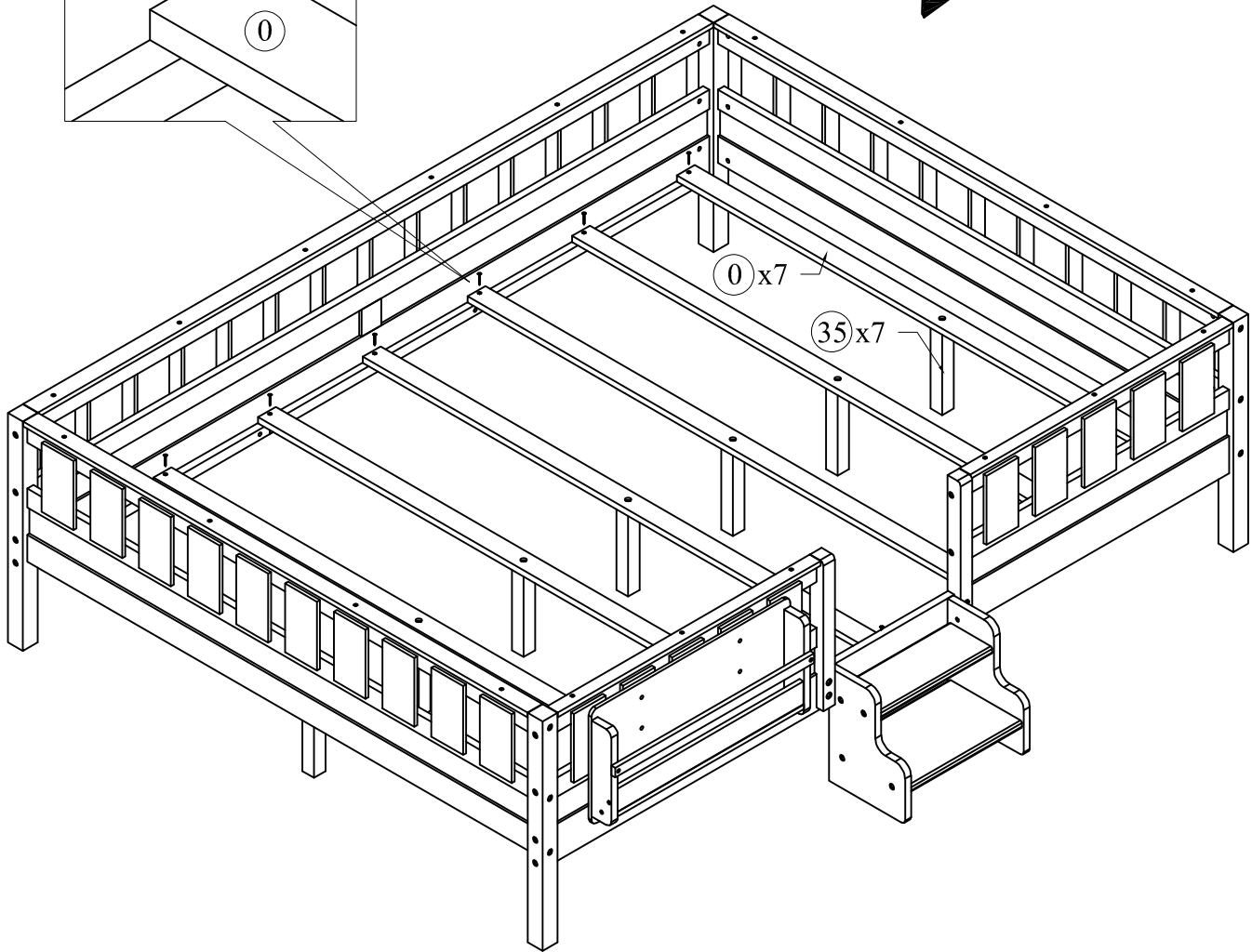
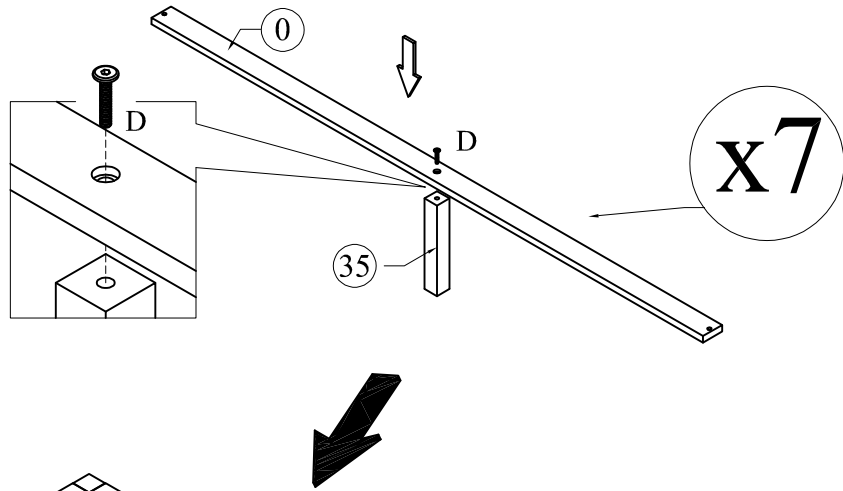
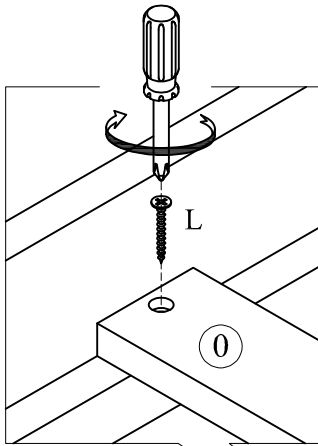

# STEP 16

(N)		04
-----	---	----

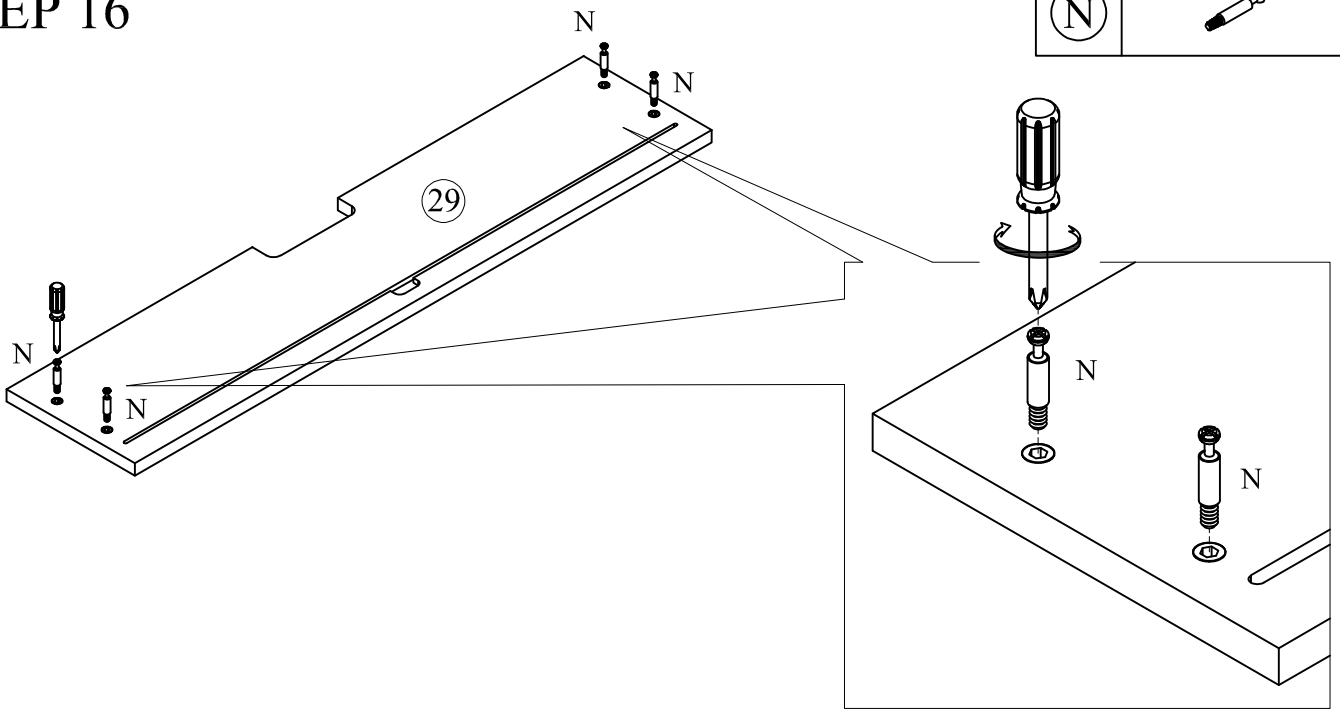

# STEP 17

(N)		04
-----	---	----

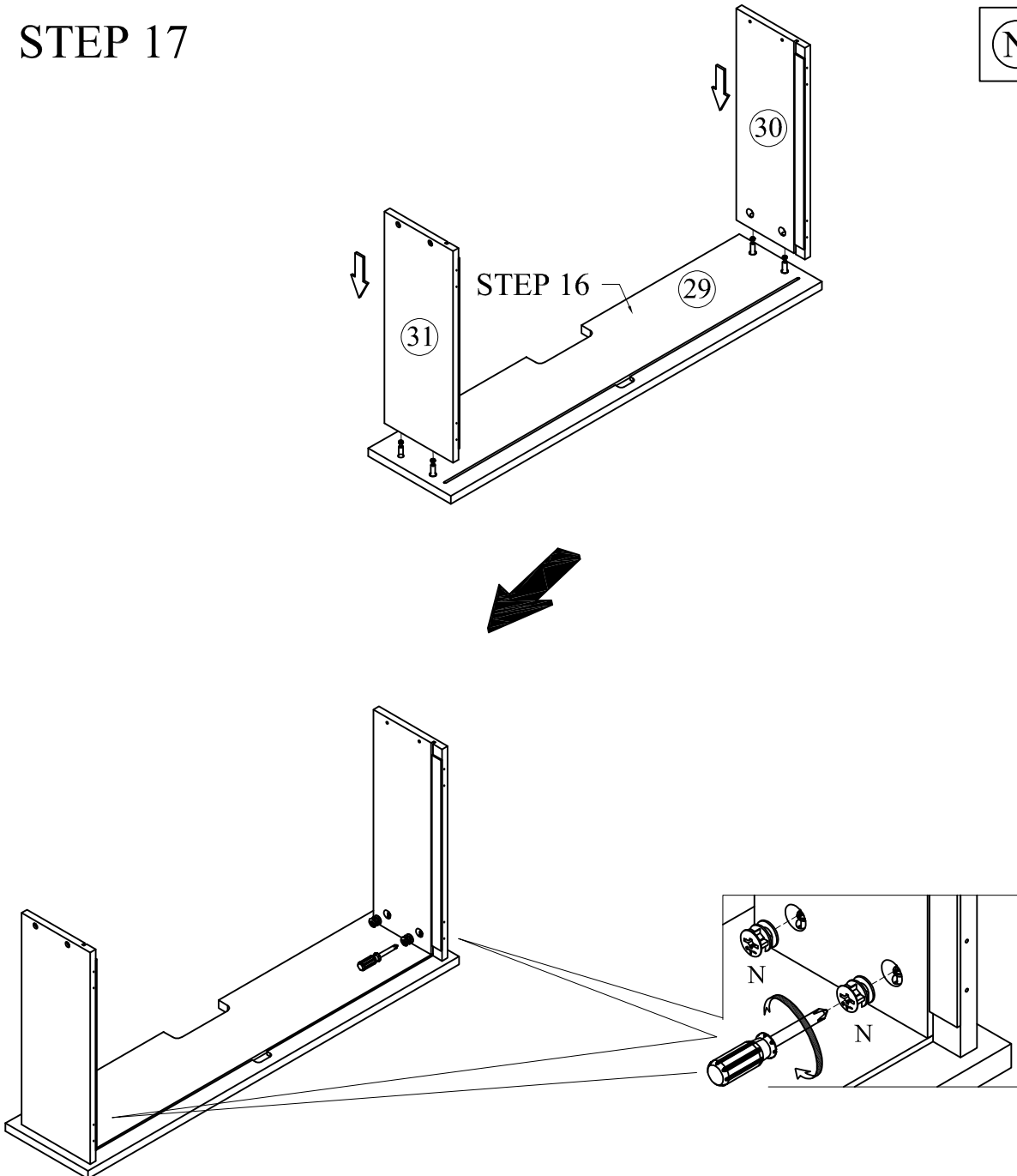

# STEP 18

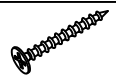

(M)

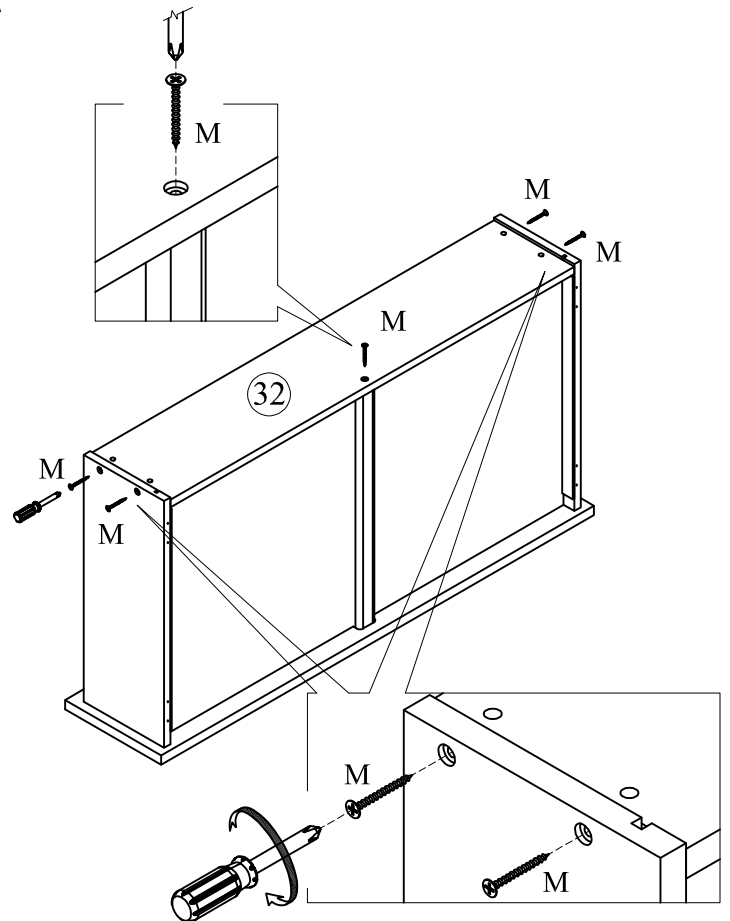
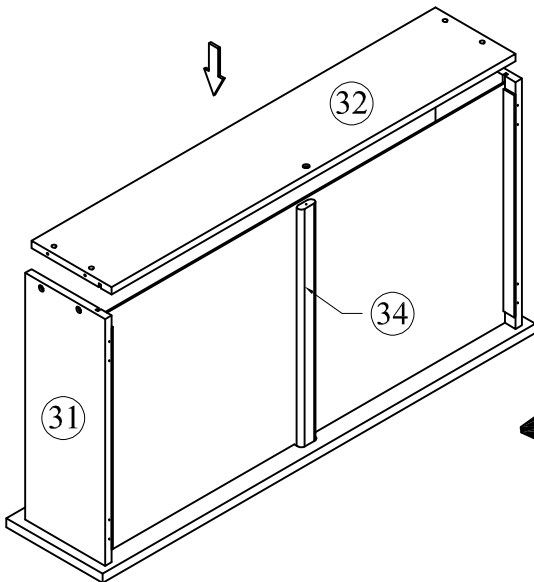
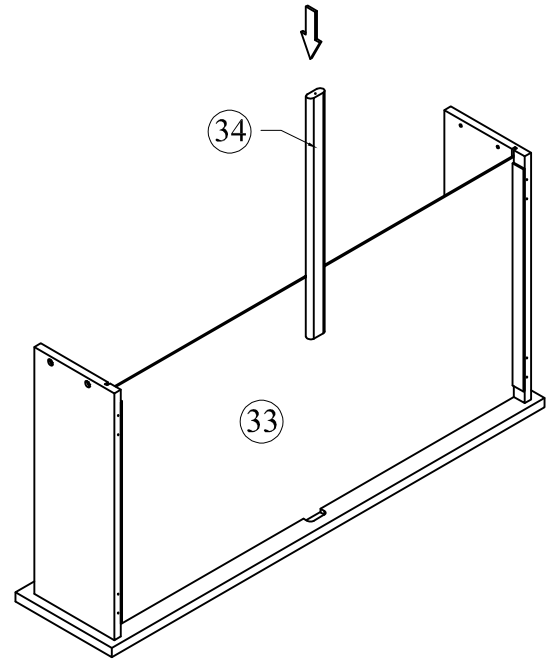
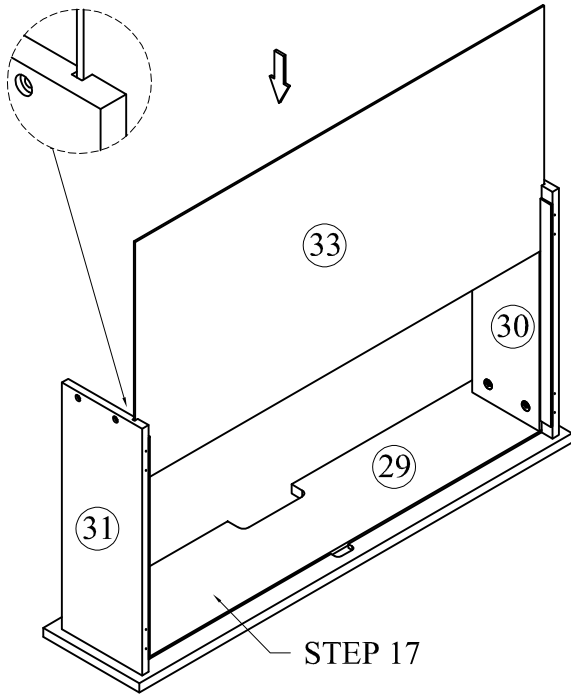
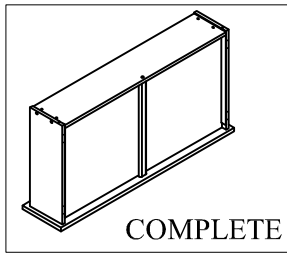

05



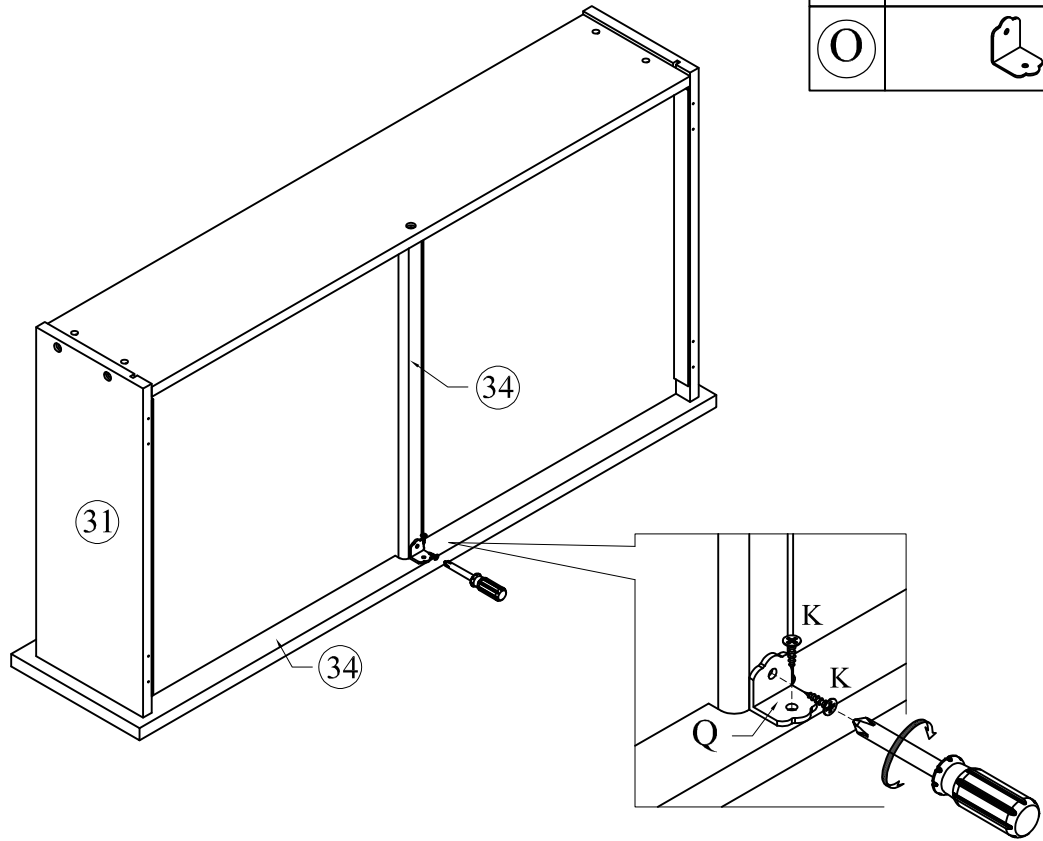

# STEP 19

(K)		02
(O)		01





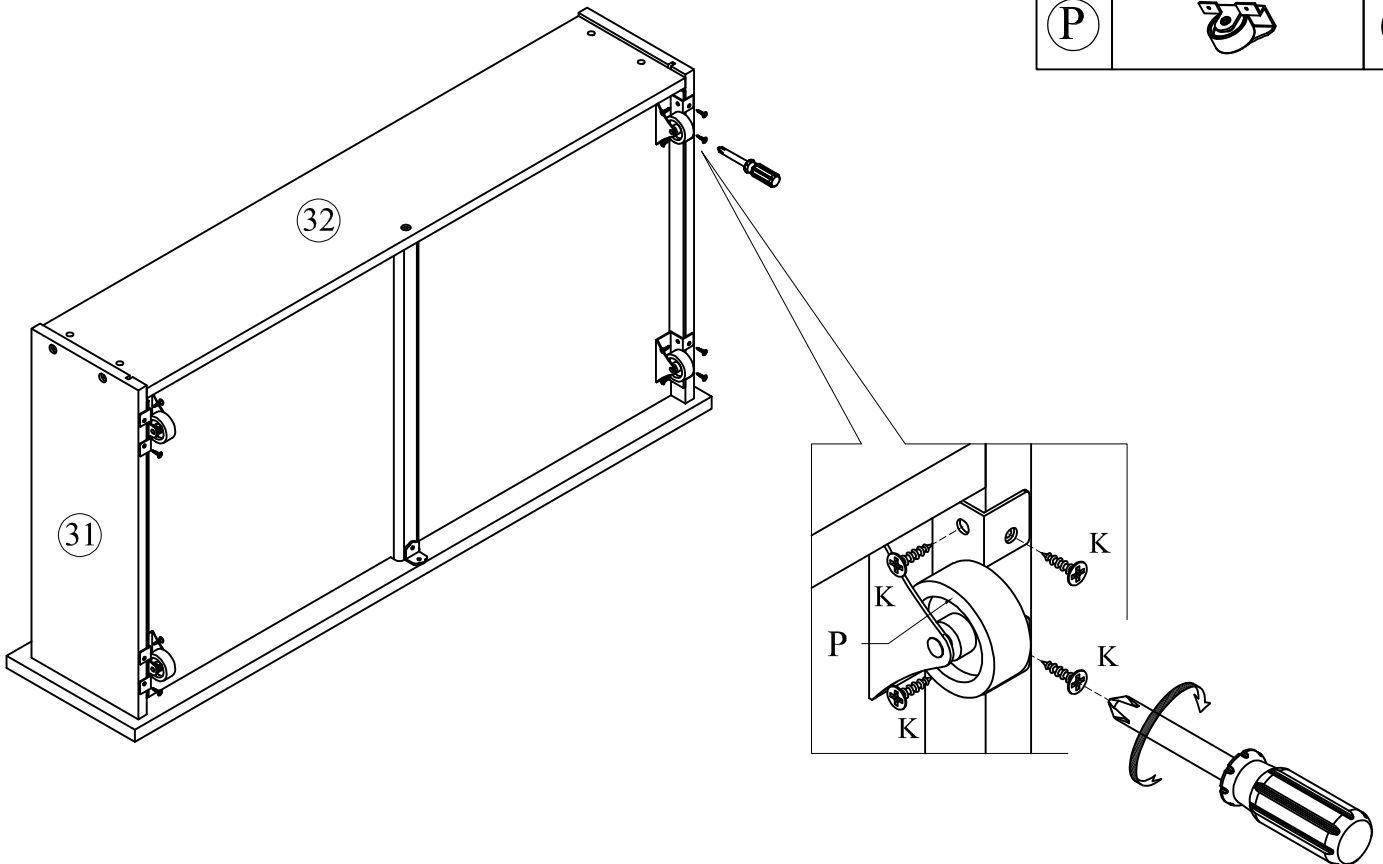

# STEP 20

(K)		16
(P)		04



# STEP 21

Ⓚ		18
Ⓜ		05
Ⓝ		04
Ⓞ		01
Ⓟ		04

\* ...Repeat the assembly steps from Step 16 to Step 20 to complete the second Drawer.

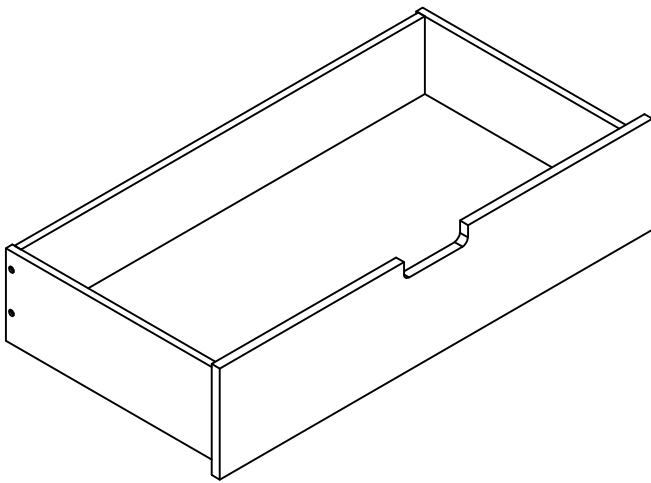

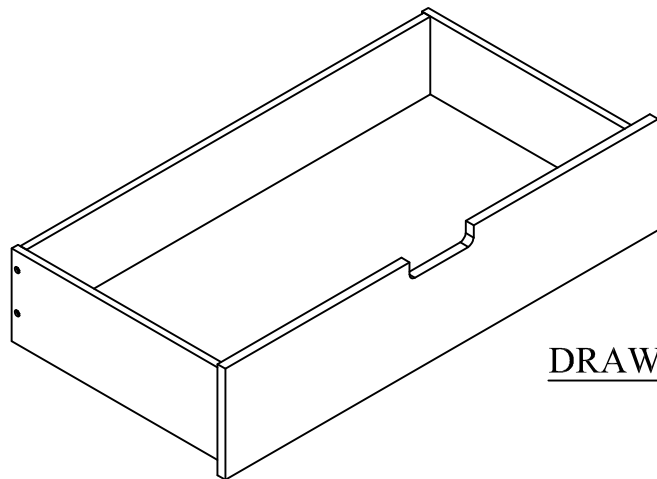

DRAWER 1



DRAWER 2

# STEP 22

(M)		08
(R)		04

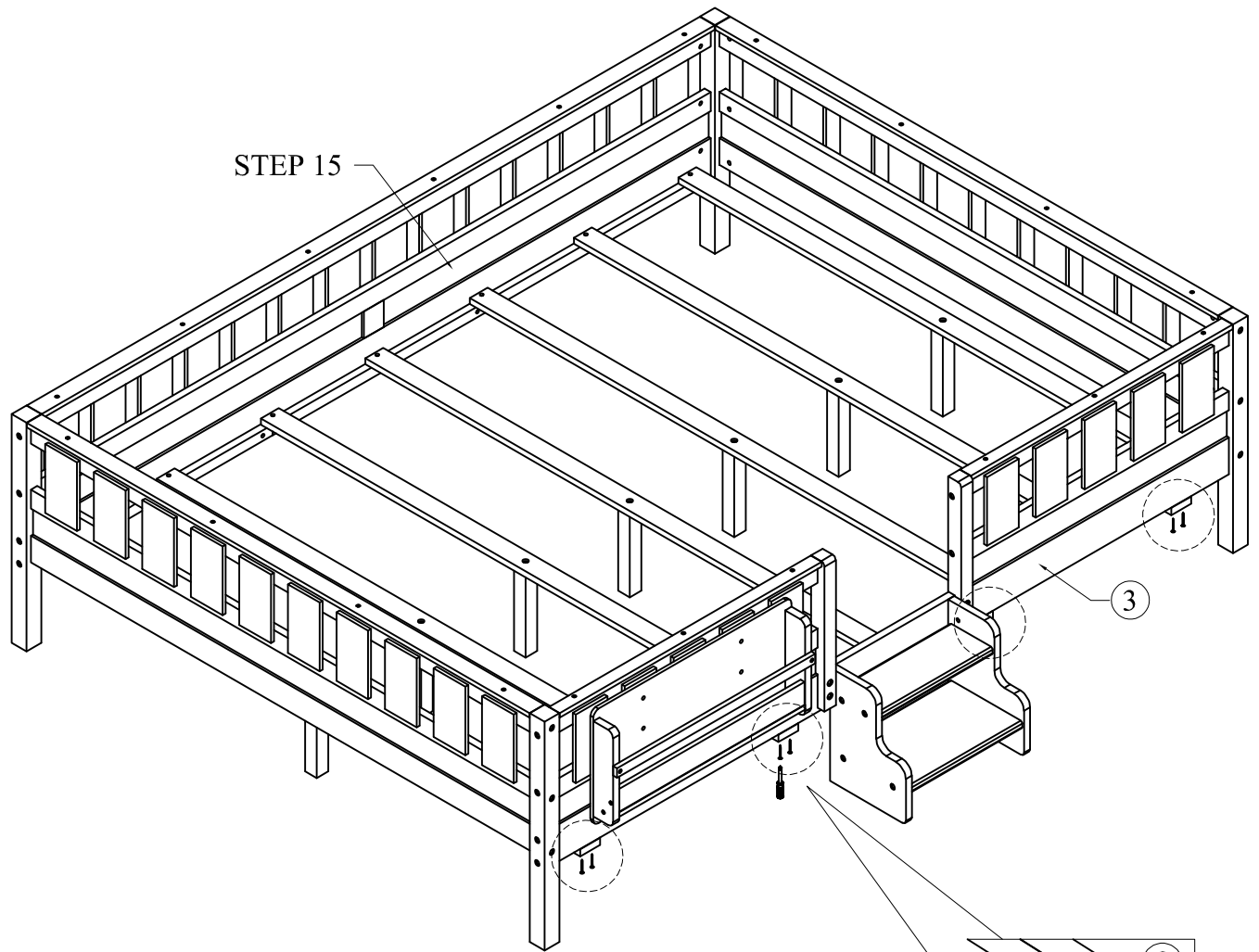

The wooden stops are securely attached underneath the slat support (part 3)..

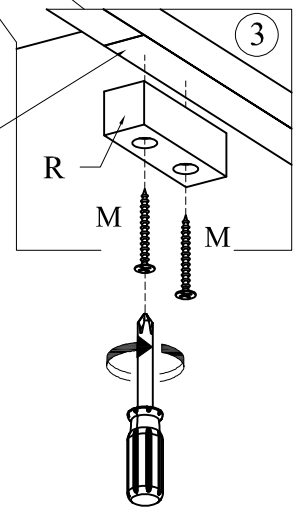

# STEP 23

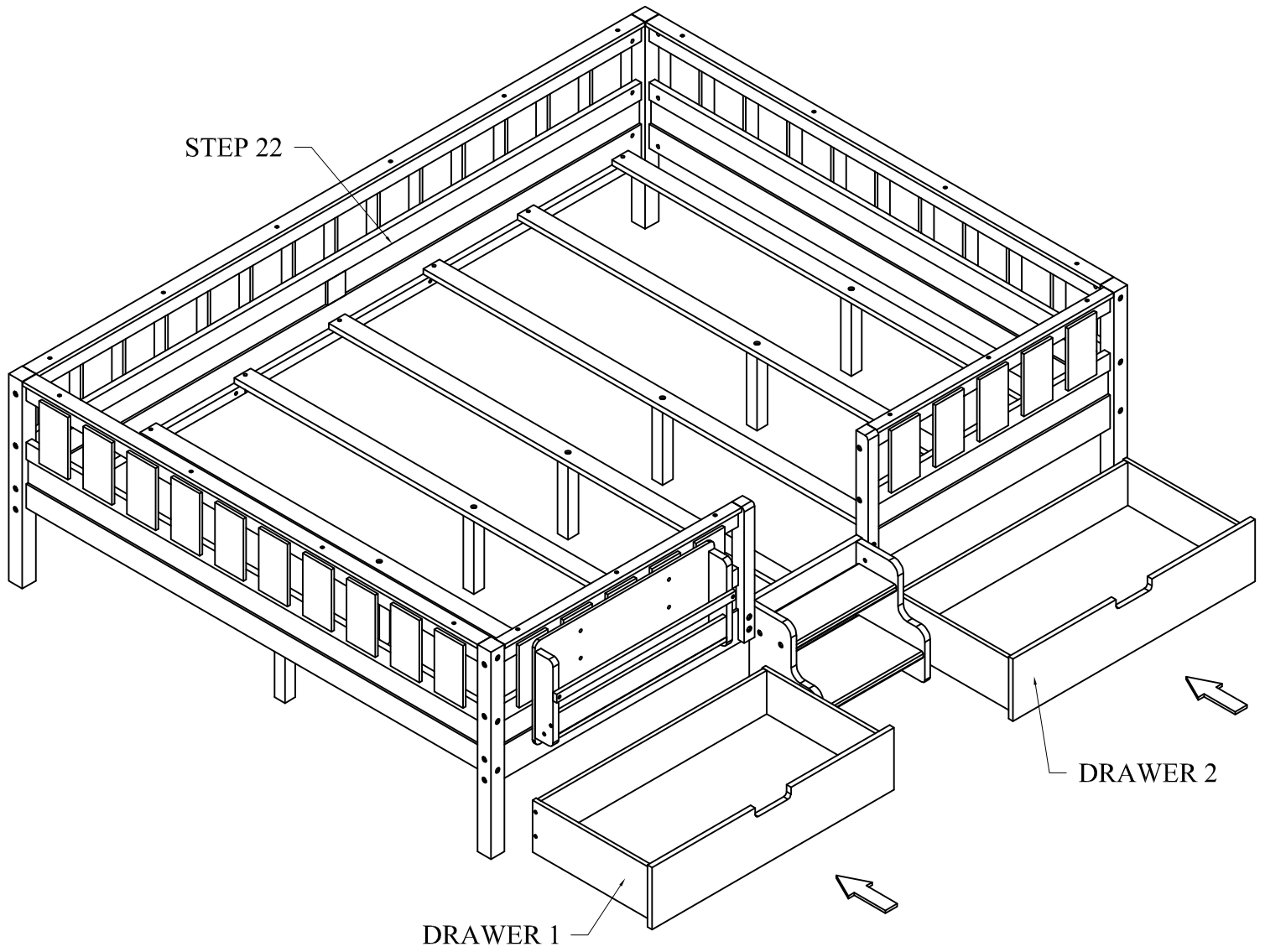

Check and fully tighten all bolts in the assembly steps to ensure a solid structure.

# COMPLETED

