

ASSEMBLY INSTRUCTION

BOX #Armrests

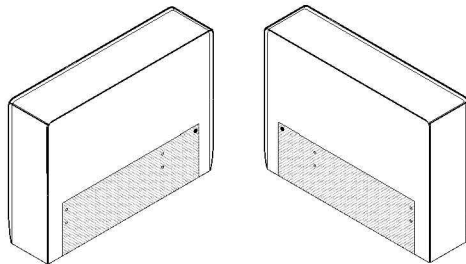

1

RIGHT ARMREST

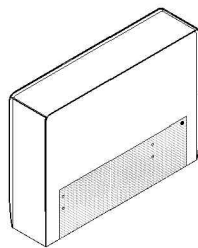

x1

2

LEFT ARMREST

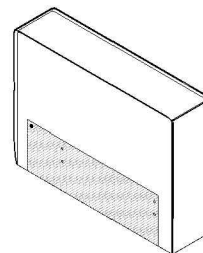

x1

A

DOUBLE-ENDED SCREW



M8x 70mm

x 10

B

NUT



M8

x 10

C

WASHER



M8

x 10

BOX #Armless Seat

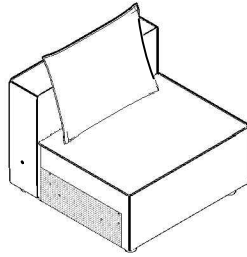

3

SOFA SEAT

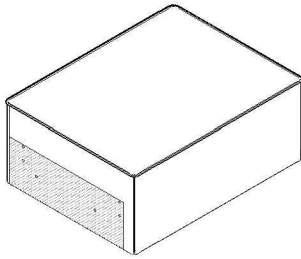

x1

4

SOFA BACKREST

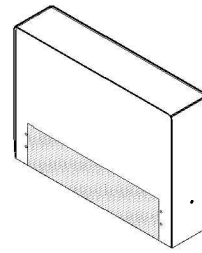

x1

5

WOODEN LEG

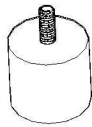

x4

6

BACK CUSHION

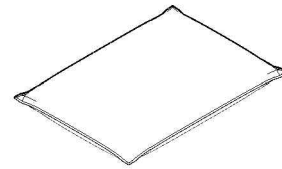

x1

A

DOUBLE-ENDED SCREW



M8x 70mm

x 6

B

NUT



M8

x 8

C

WASHER



M8

x 8

D

SOCKET

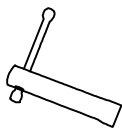

M8

x 1

ACCENT ARM CHAIR

If you got an accent arm chair, please follow these steps to assemble it.

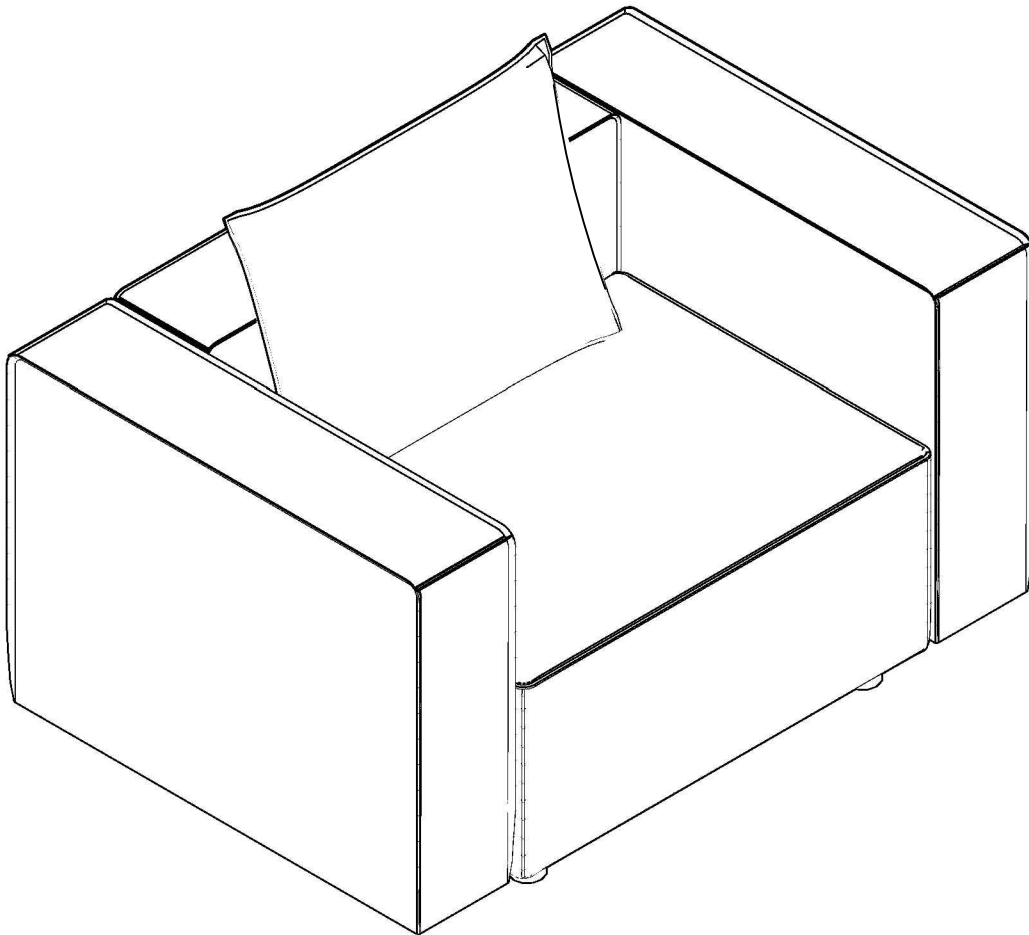

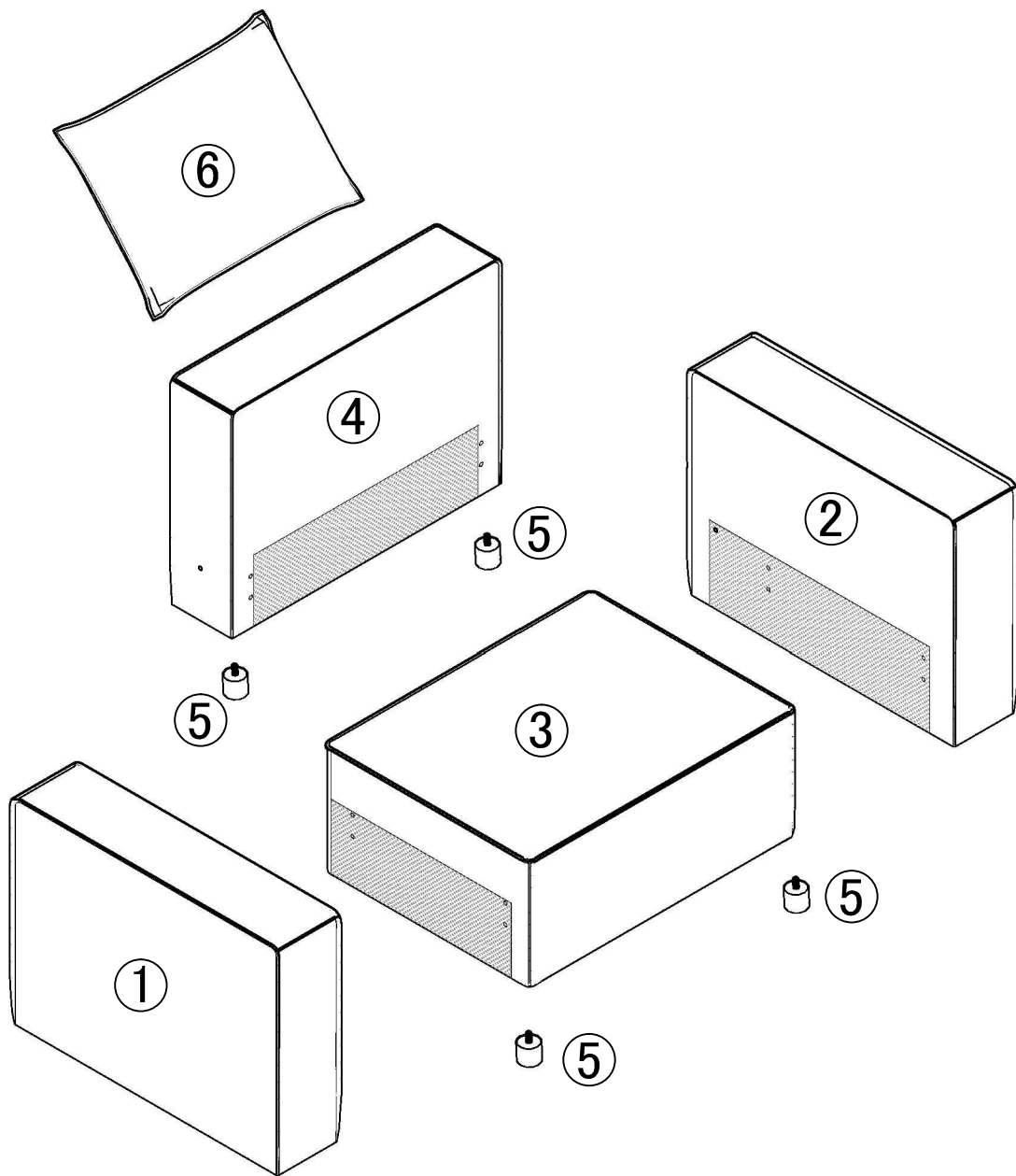

Decomposition diagram of sofa components

1

| | |
|---|-----|
| ④ | × 1 |
| A | × 4 |

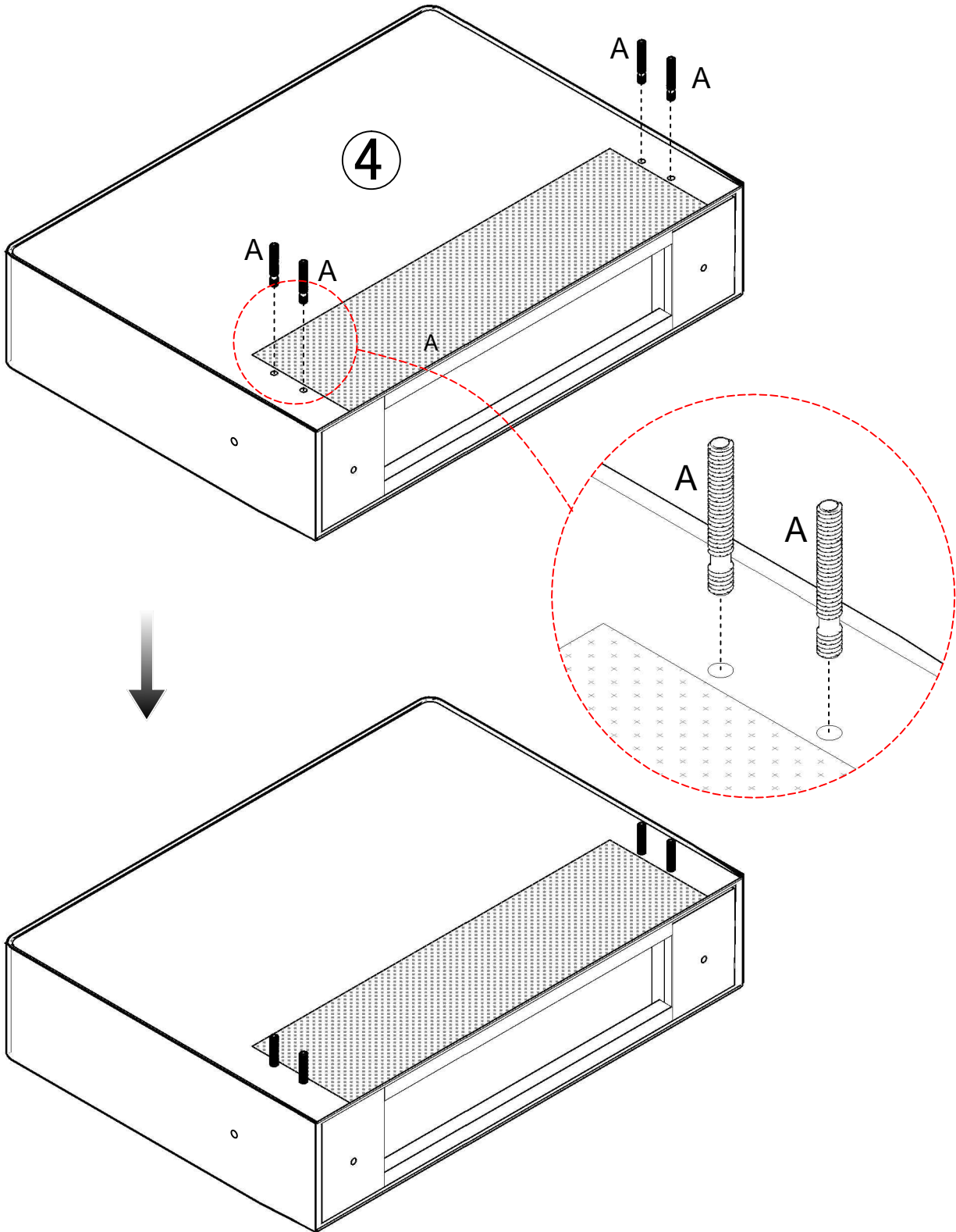

Lock the M8 * 70mm long screw onto the sofa backrest

2

| | |
|---|-----|
| ③ | × 1 |
| B | × 4 |
| C | × 4 |
| D | × 1 |

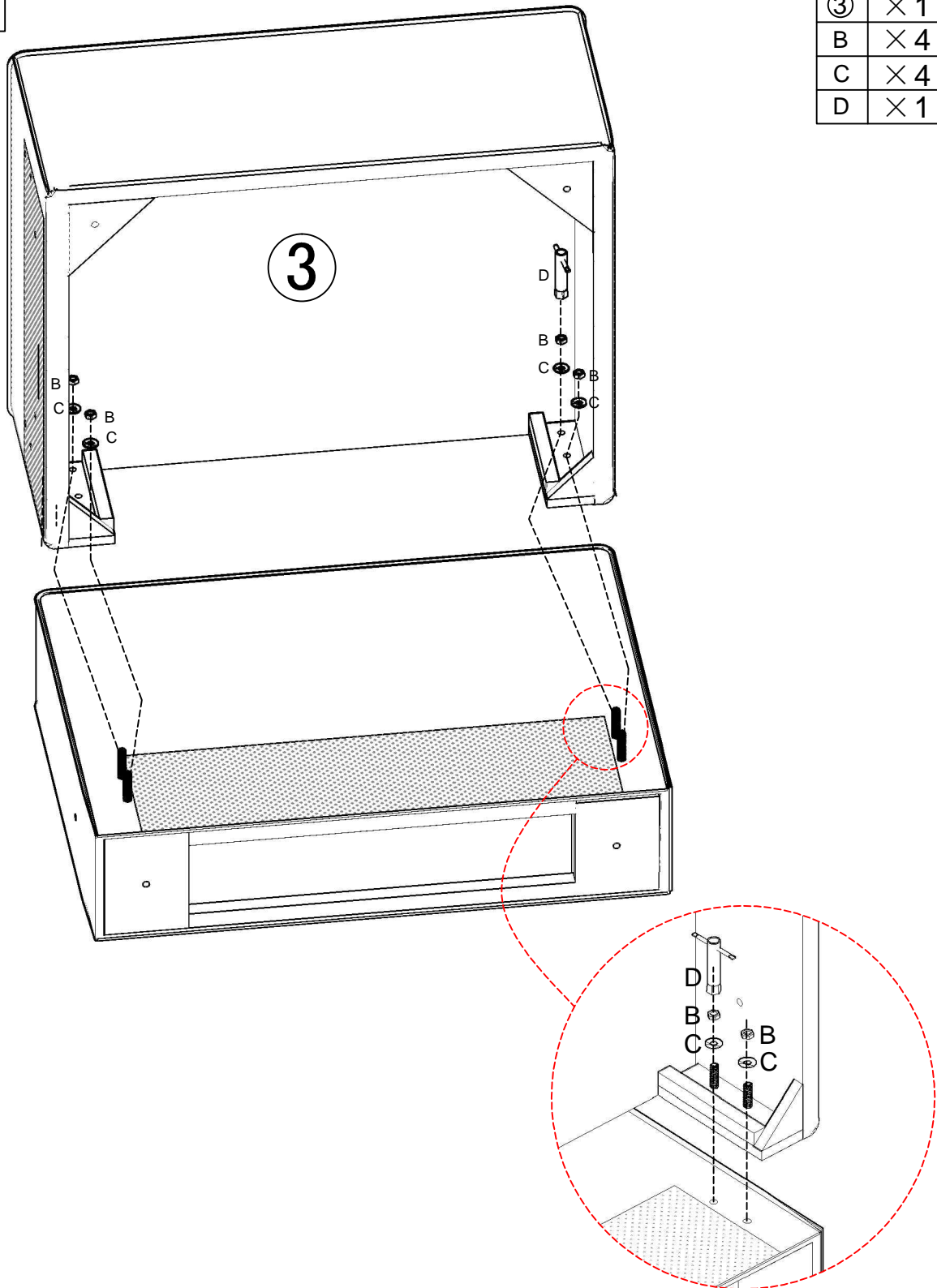

Attach seat frame and backrest plate with M8 double head screws #A, install spacers #C and nuts #B, and tighten with socket wrench #D.

3

| | |
|---|------|
| ① | × 1 |
| ② | × 1 |
| A | × 10 |

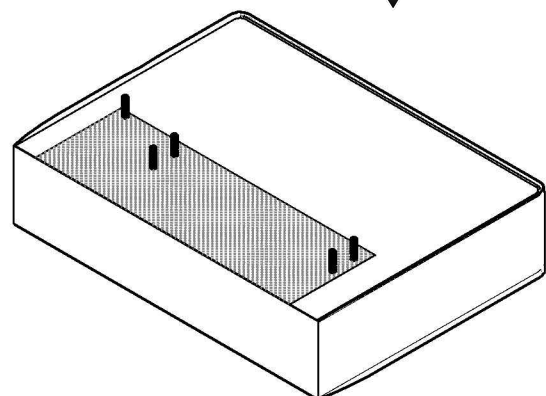
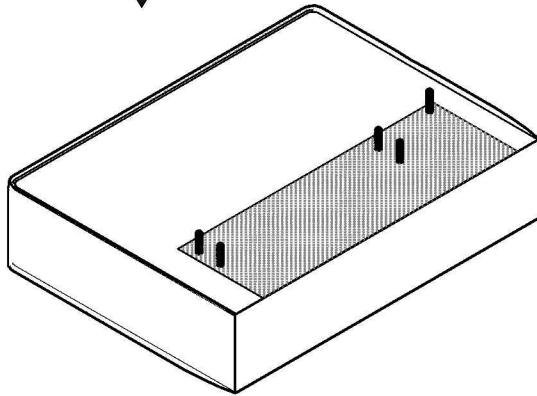
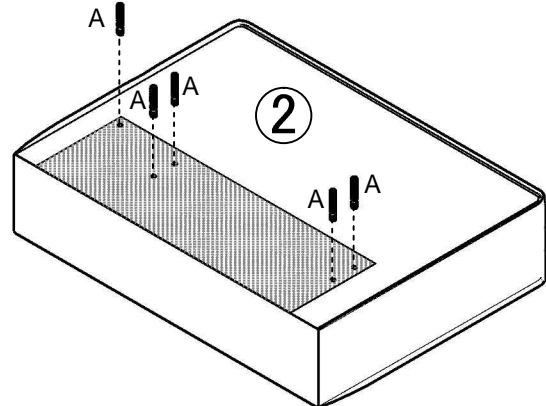
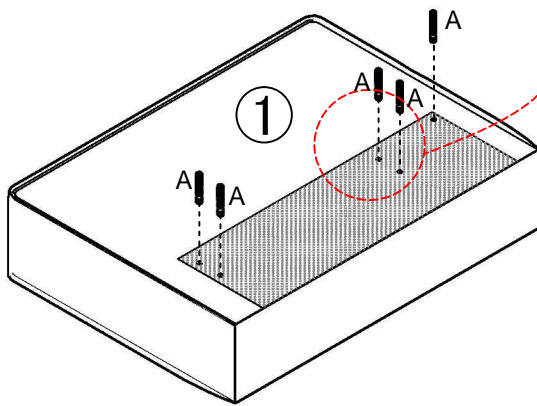
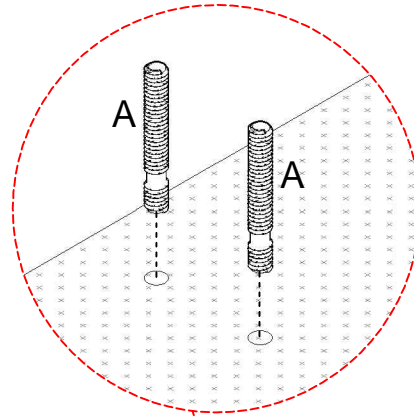

Lock the M8 * 70mm long screw onto the armrest base

4

| | |
|---|-----|
| ① | ×1 |
| ② | ×1 |
| B | ×10 |
| C | ×10 |
| D | ×1 |

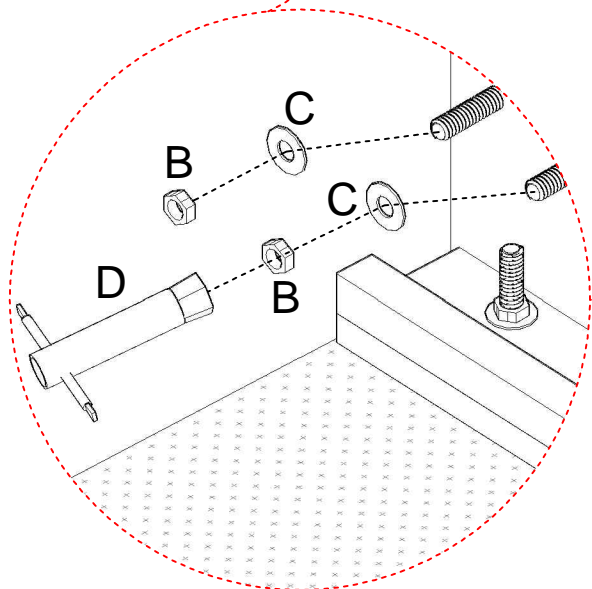
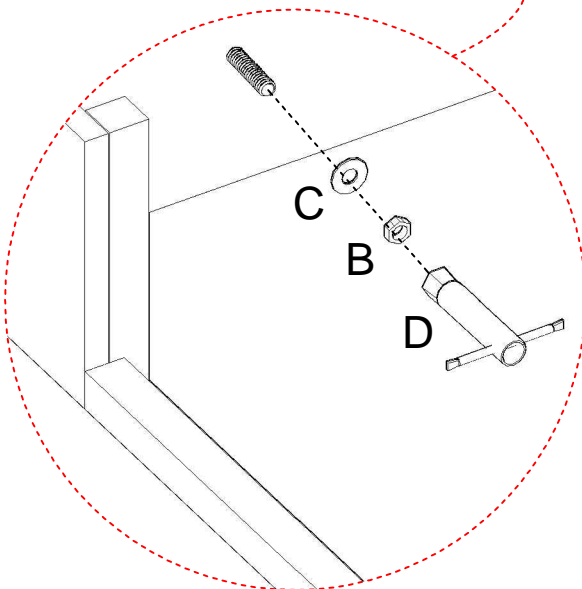
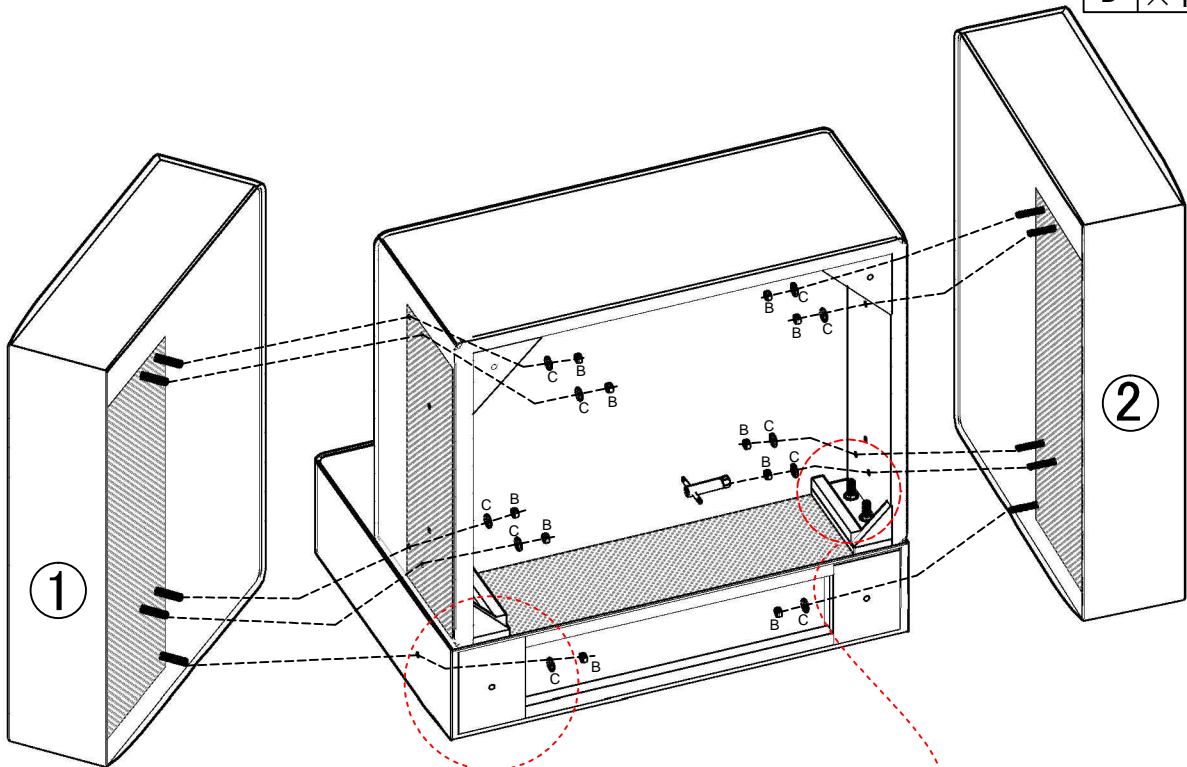

Use M8 double-ended screws #A to connect armrest and seat base, install spacers #C and nuts #B, and secure by tightening with a socket wrench #D

5

⑤ × 4

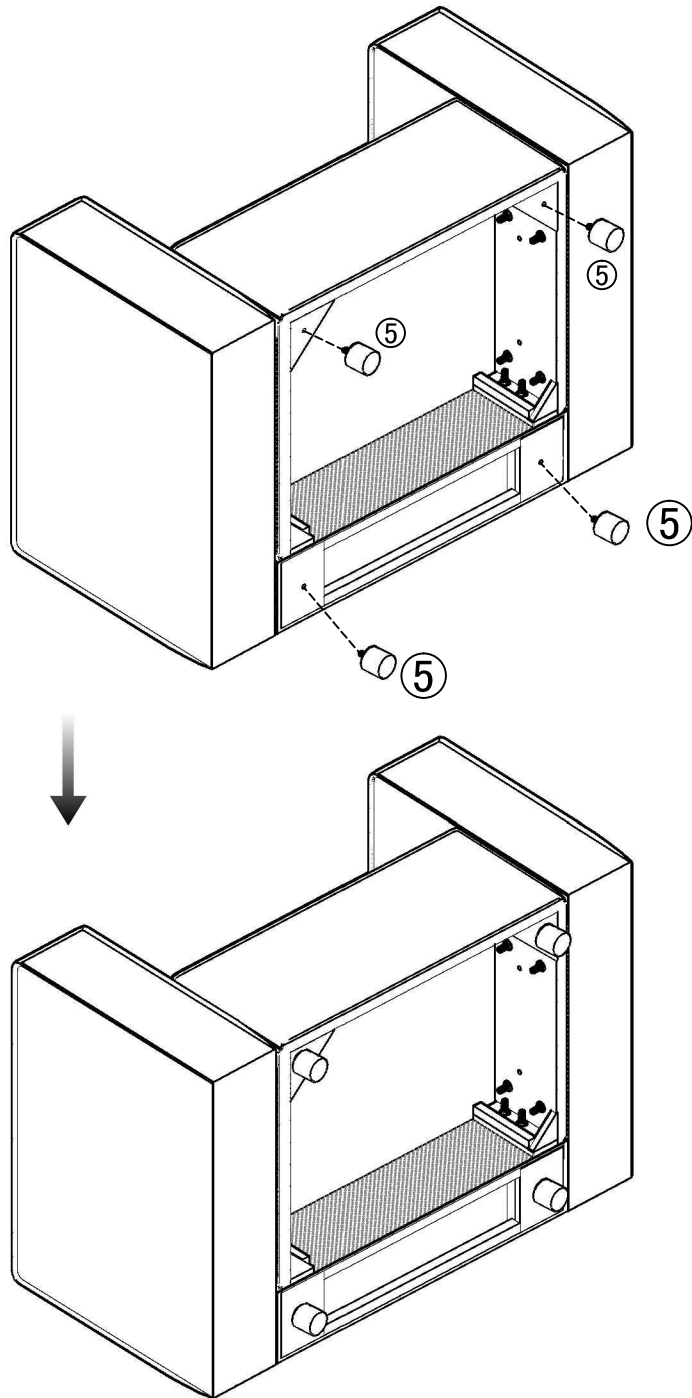

Assemble the sofa legs on the bottom triangle frame

6

⑥ × 1

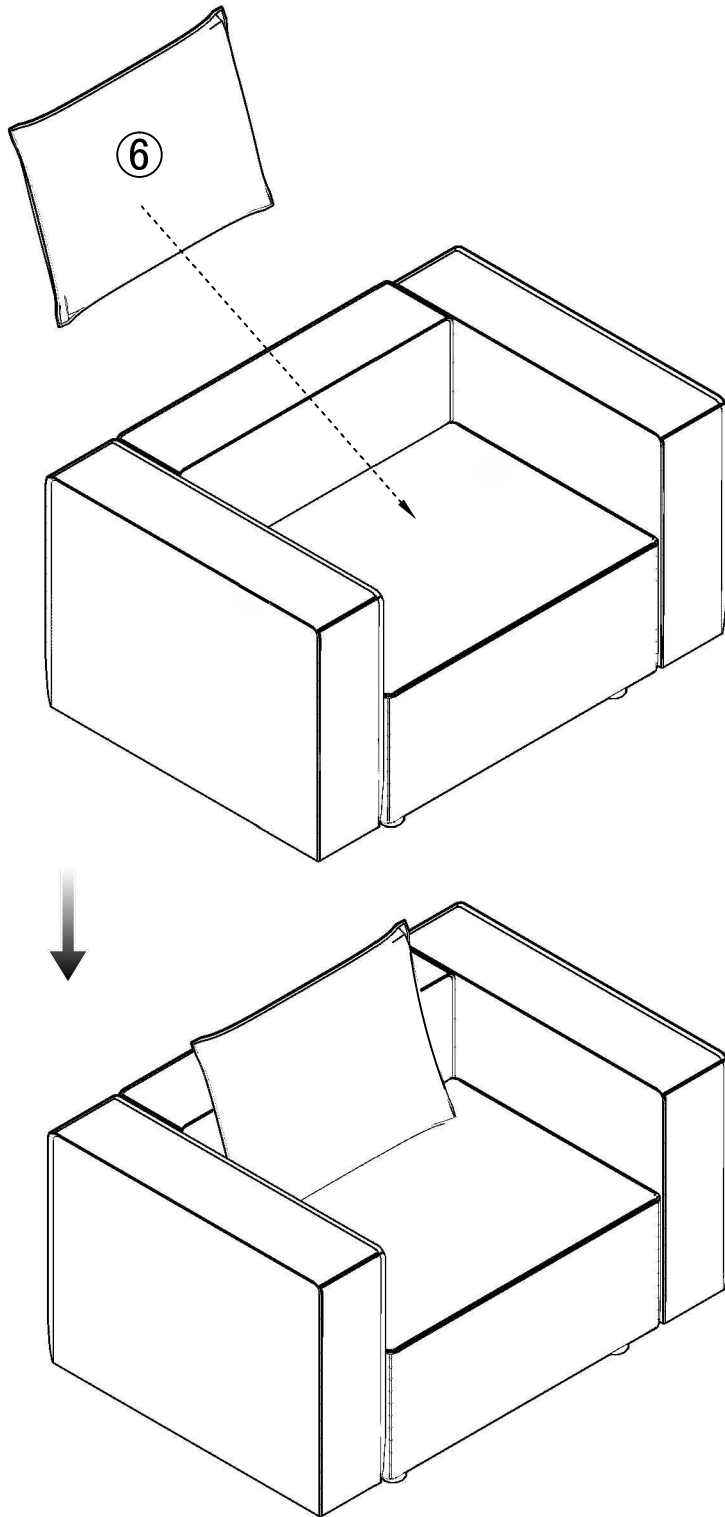

Place the cushions on the sofa

MODULAR SOFA(TWO-SEAT)

If you got a two-seat sofa, please follow these steps to assemble it.

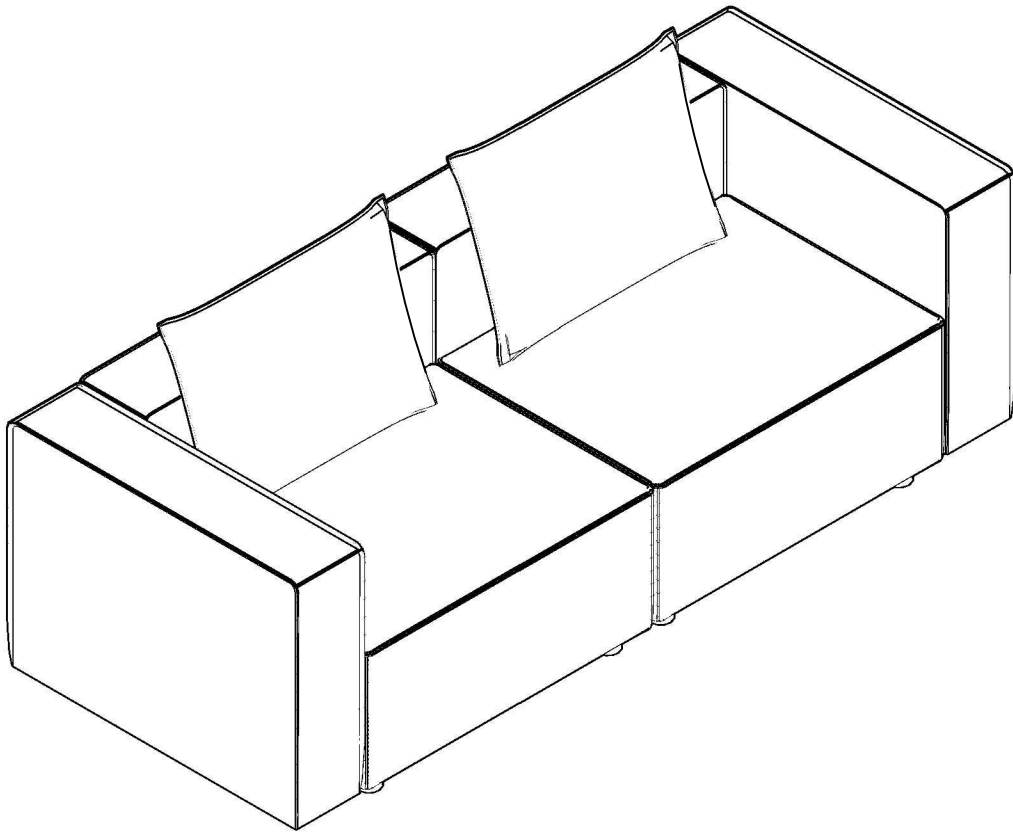

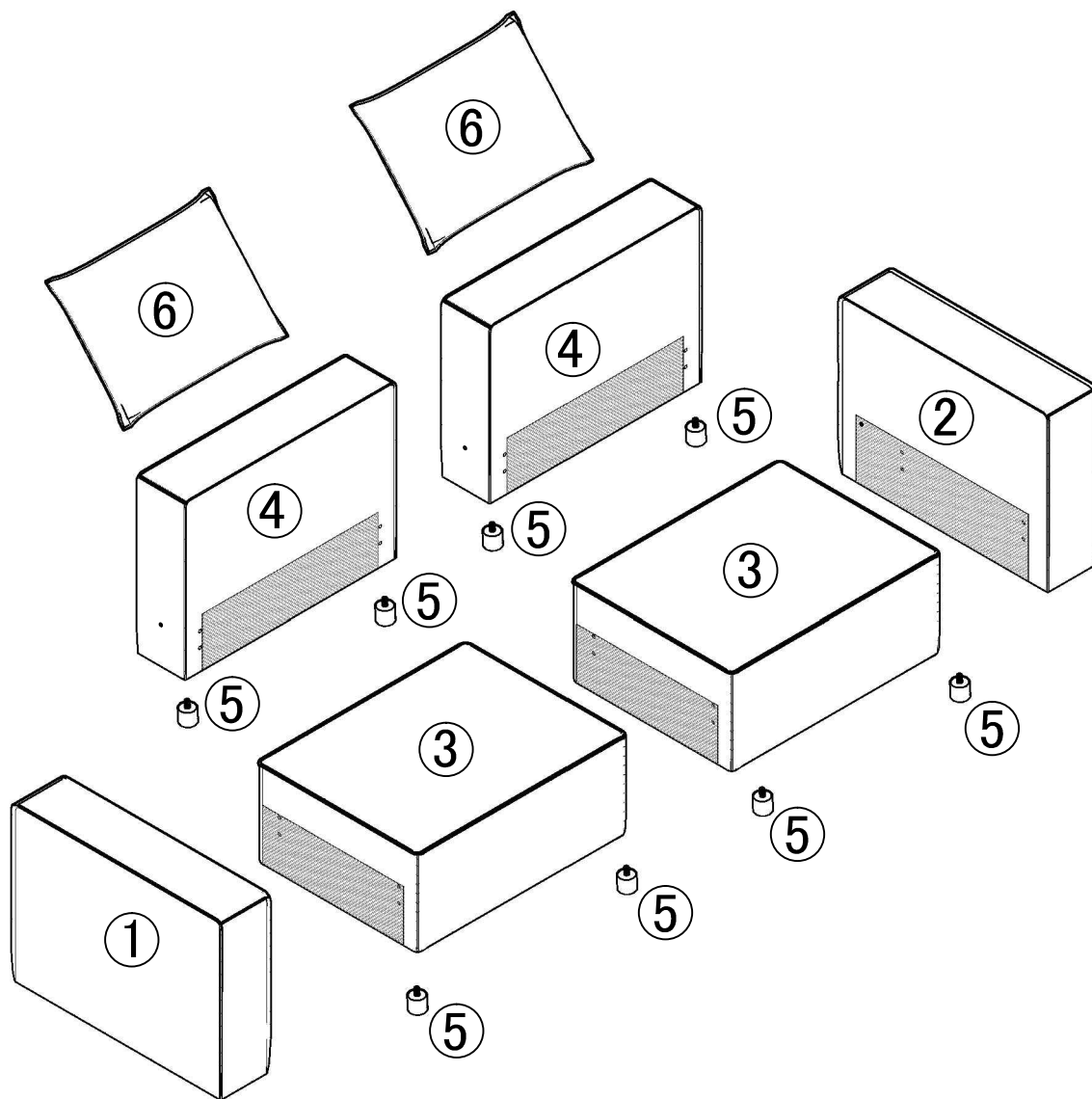

Decomposition diagram of sofa components

1

| | |
|---|-----|
| ④ | × 2 |
| A | × 8 |

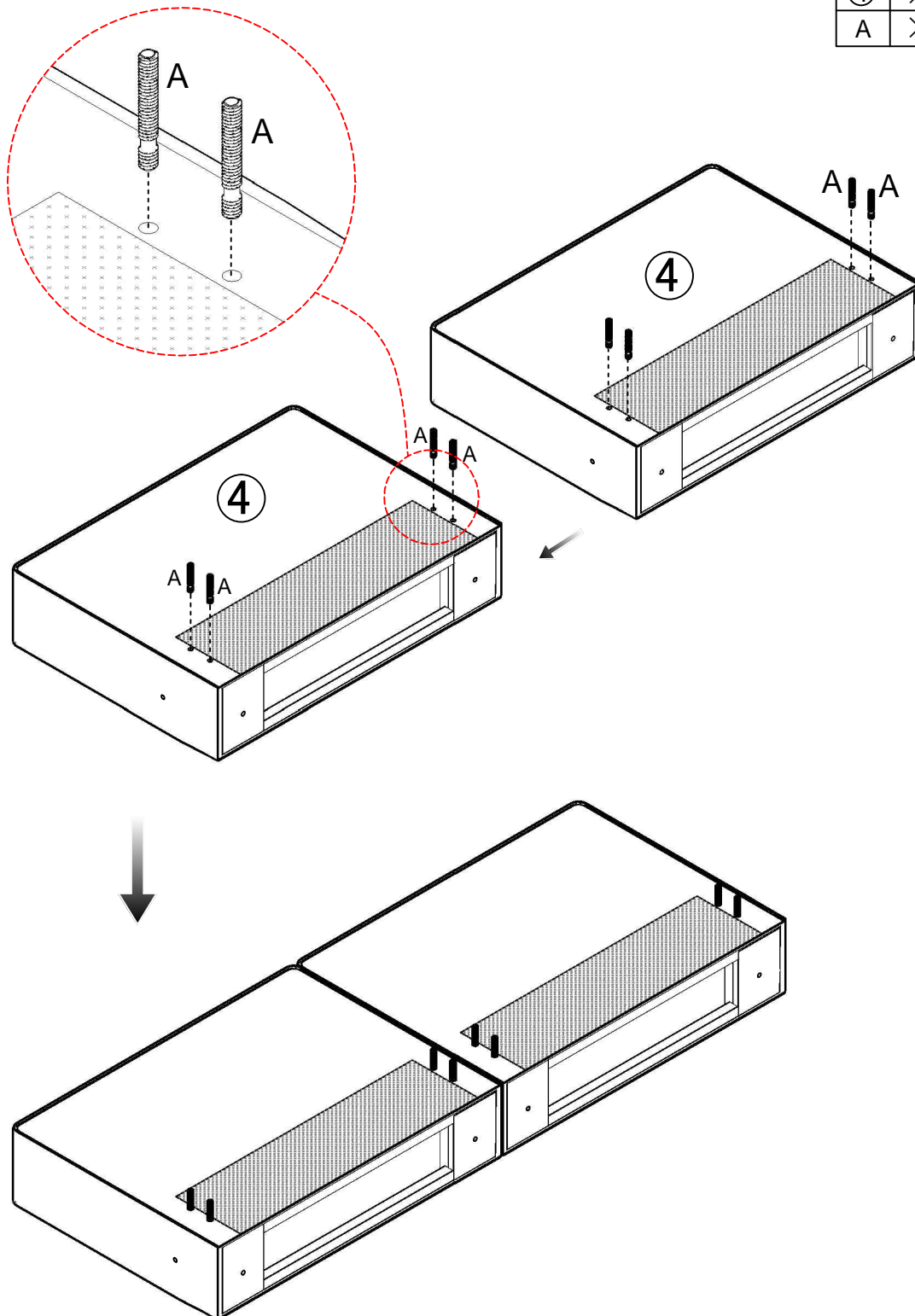

Lock the M8 * 70mm long screw onto the sofa backrest

2

| | |
|---|-----|
| ③ | × 2 |
| B | × 8 |
| C | × 8 |
| D | × 1 |

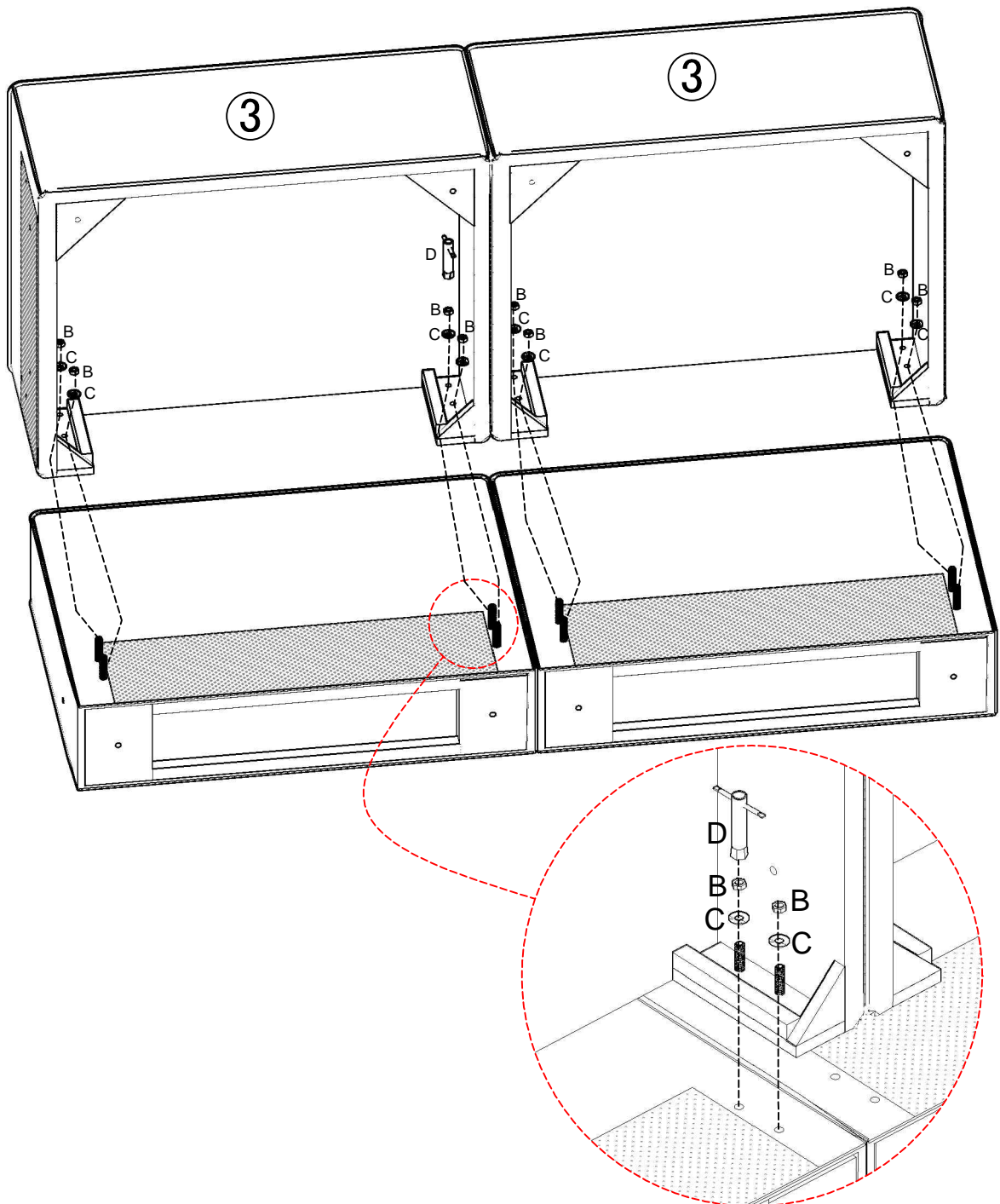

Attach seat frame and backrest plate with M8 double head screws #A, install spacers #C and nuts #B, and tighten with socket wrench #D.

3

NOTE:

There are six pre-drilled holes on the side of the armless seat. When connecting two seats, please accurately assemble the M8 double-ended screws #A into the center two holes. The four holes on either side do not require any assembly when connecting two seats.

| | |
|---|-----|
| A | × 2 |
| B | × 4 |
| C | × 4 |
| D | × 2 |

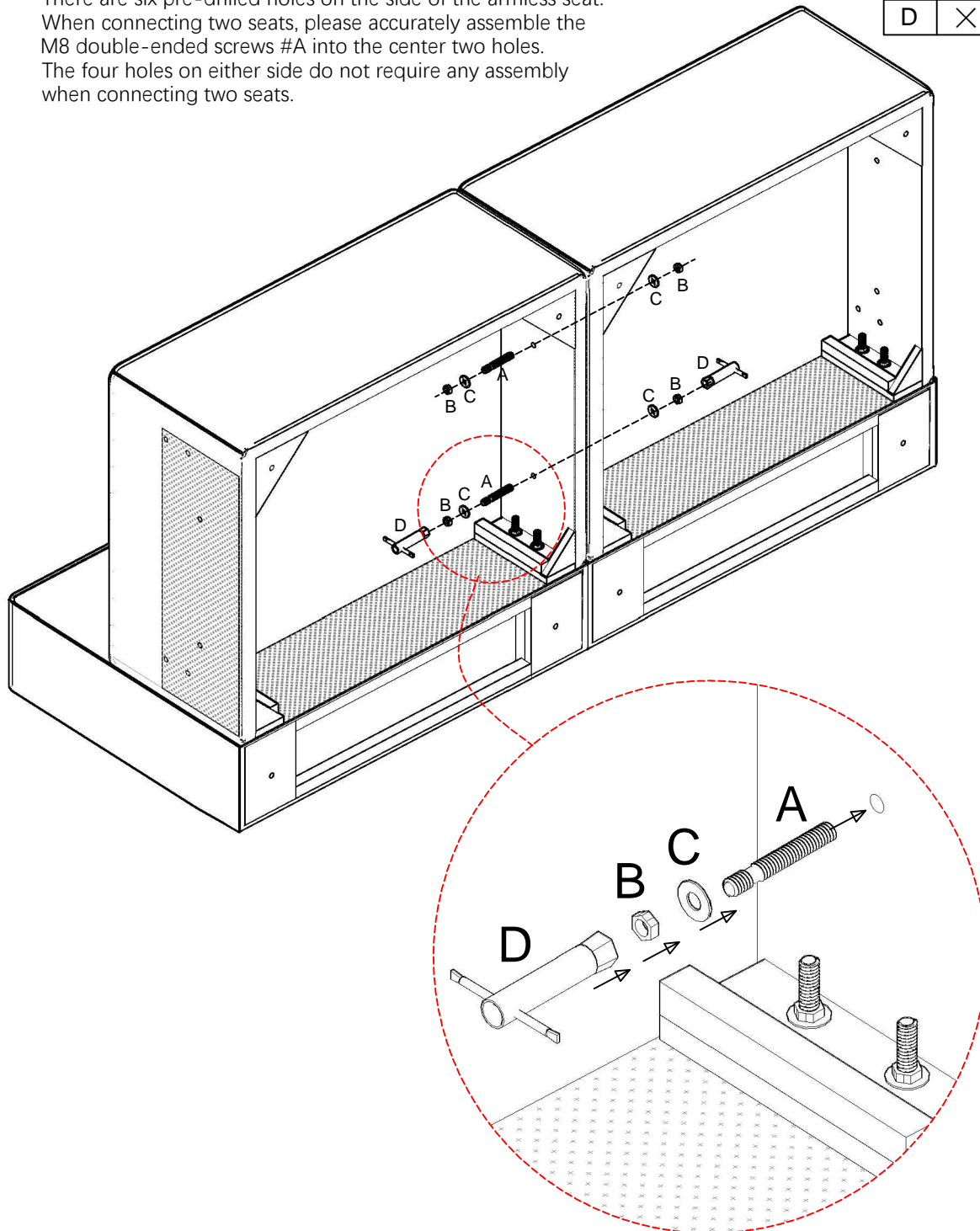

Use M8 double-ended screws #A to connect the two armless seats, install spacers #C and nuts #B, and secure by tightening with a socket wrench #D.

4

| | |
|---|------|
| ① | × 1 |
| ② | × 1 |
| A | × 10 |

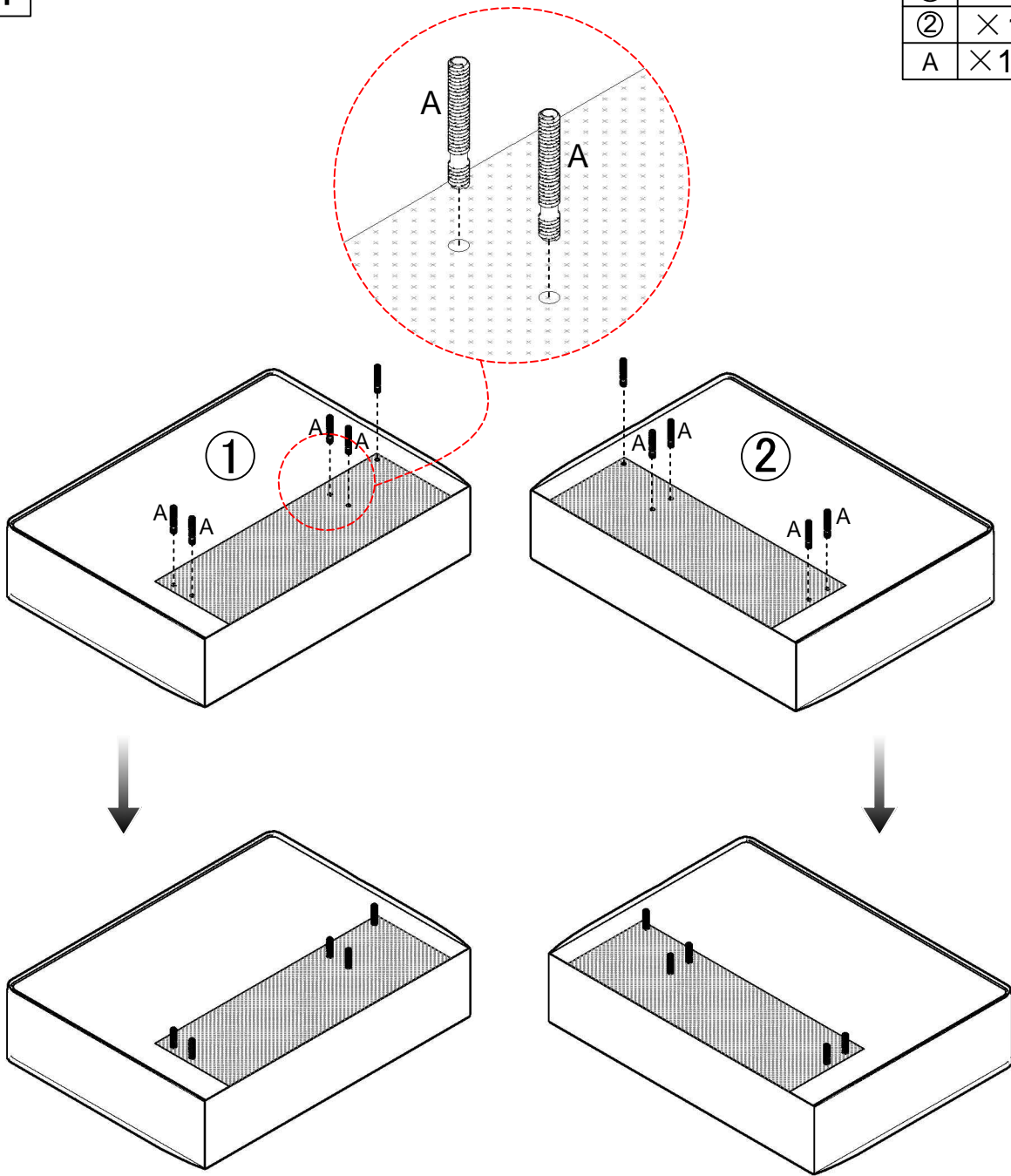

Lock the M8 * 70mm long screw onto the armrest base

5

| | |
|---|-----|
| ① | ×1 |
| ② | ×1 |
| B | ×10 |
| C | ×10 |
| D | ×1 |

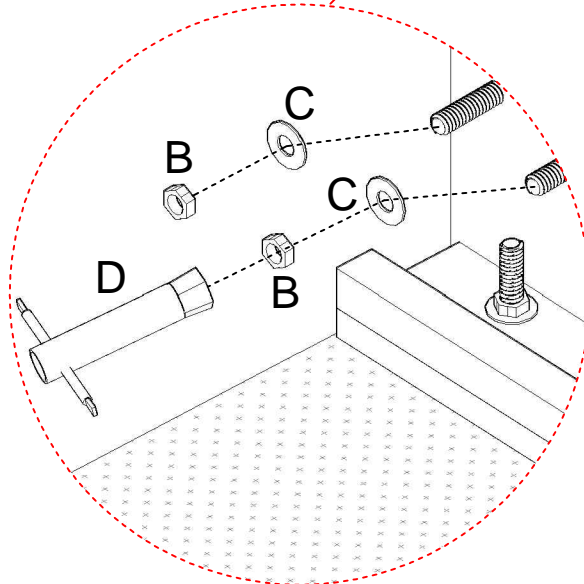
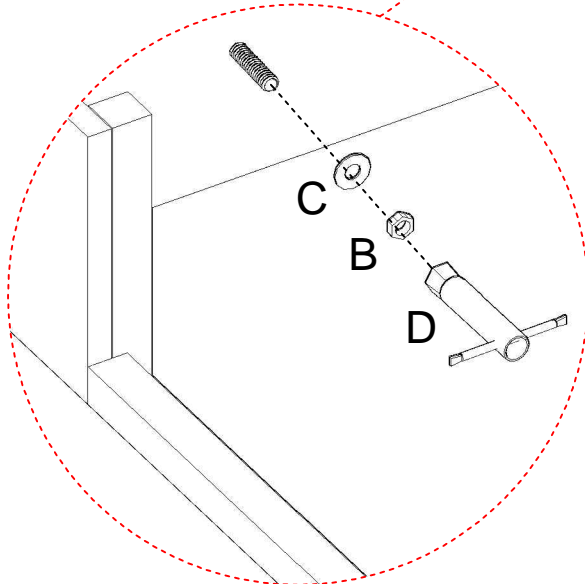
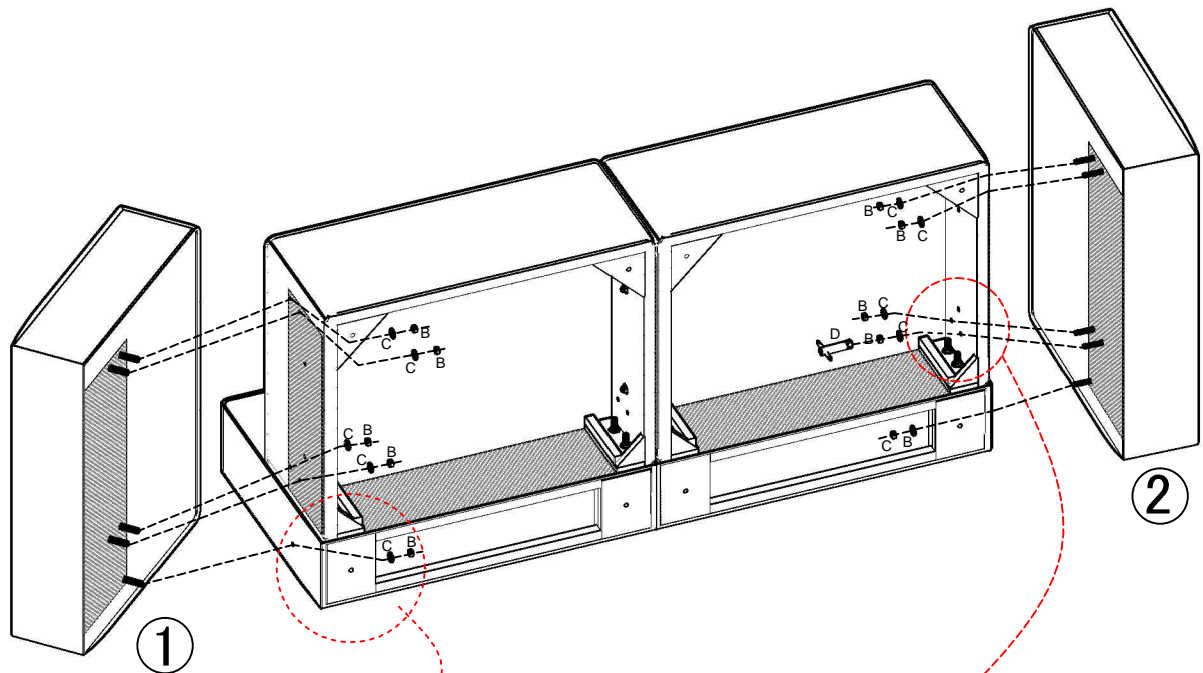

Use M8 double-ended screws #A to connect armrest and seat base, install spacers #C and nuts #B, and secure by tightening with a socket wrench #D

6

⑤ × 8

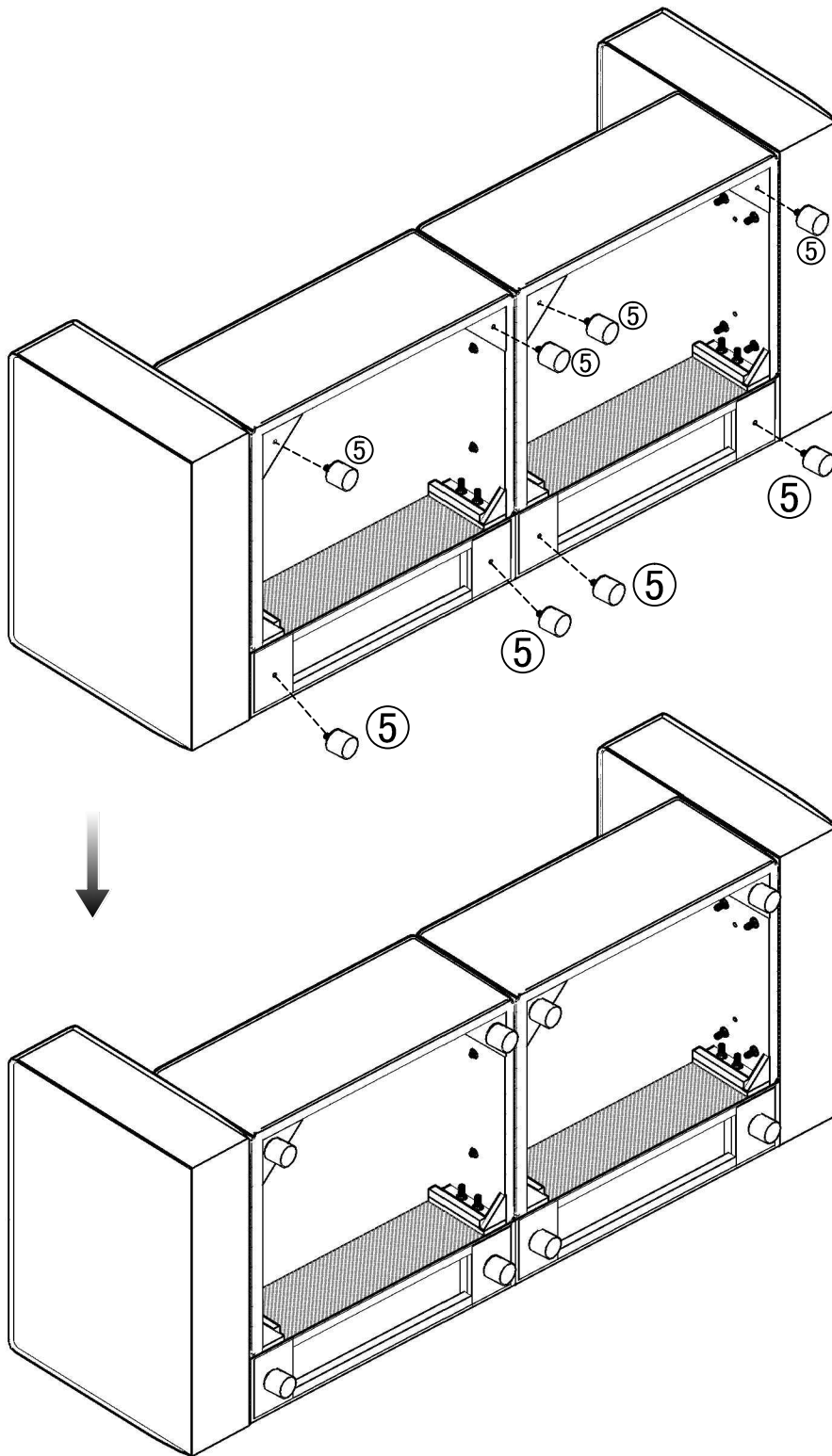

Assemble the sofa legs on the bottom triangle frame

7

⑥ × 2

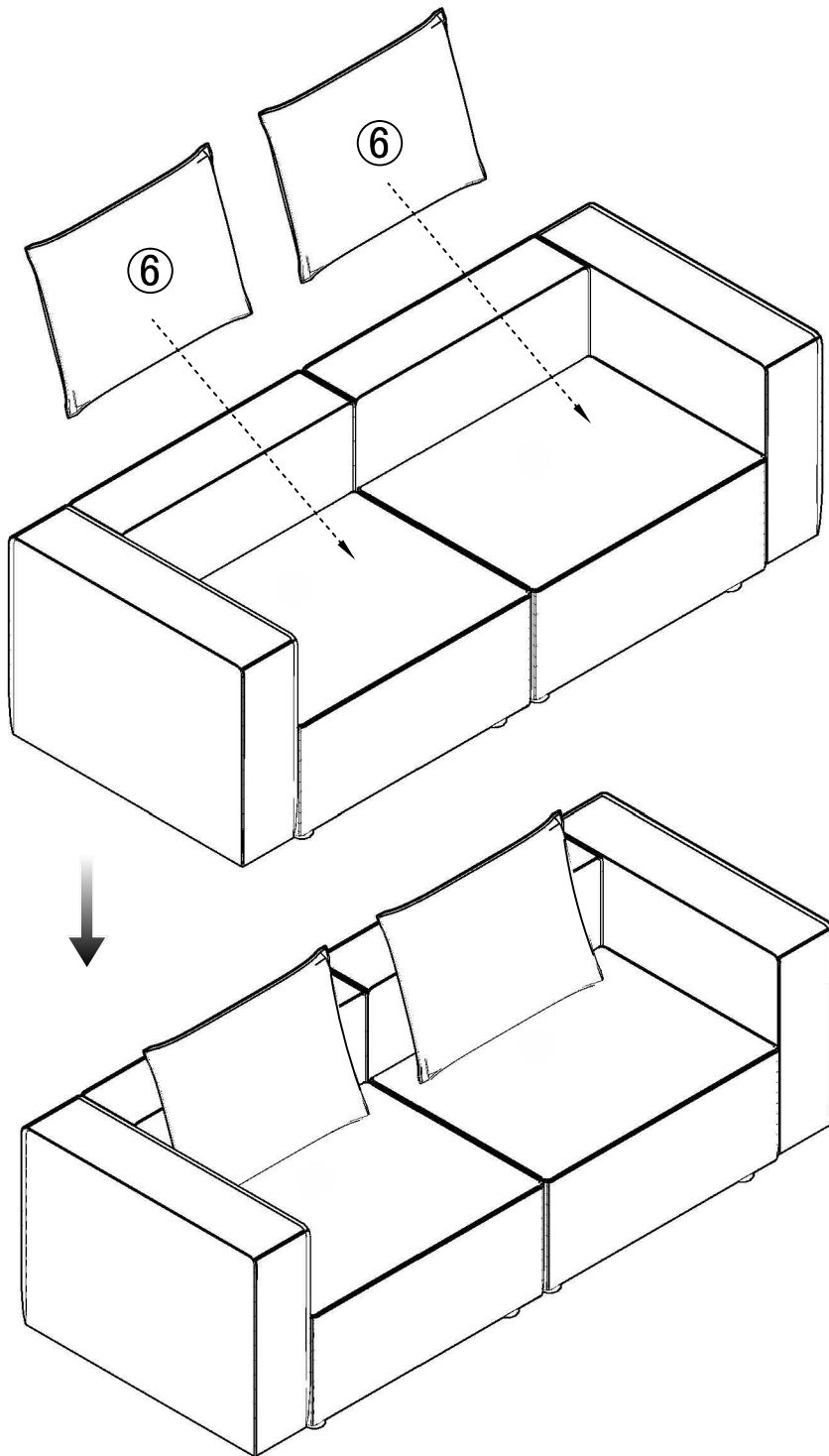

Place the cushions on the sofa

MODULAR SOFA(MULTI-SEAT)

If you got a multi-seat sofa, the assembly process is the same as for a two-seat sofa

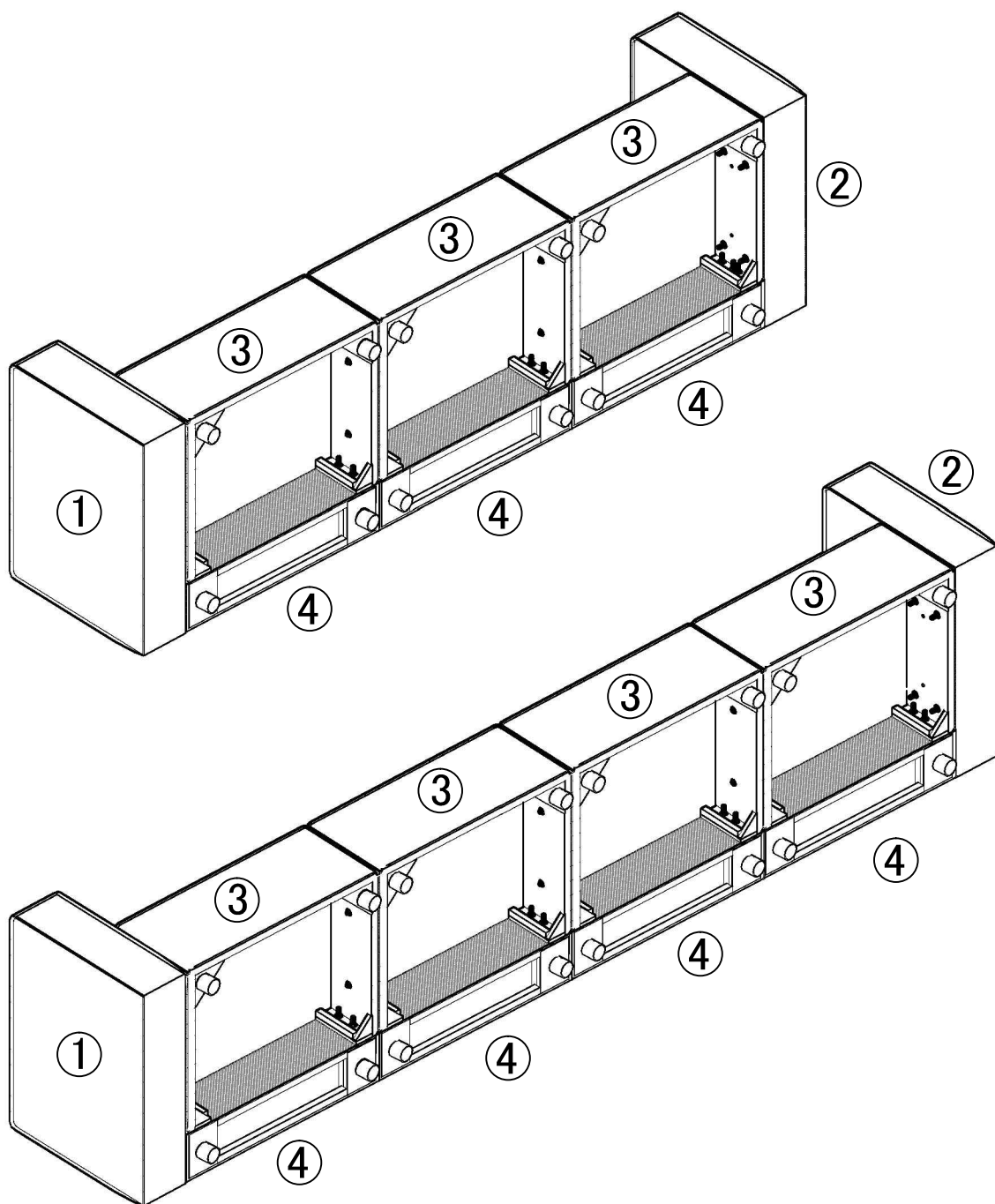

VARIOUS CONFIGURATIONS

