

ASSEMBLY INSTRUCTIONS

INSTRUCTIONS DE MONTAGE

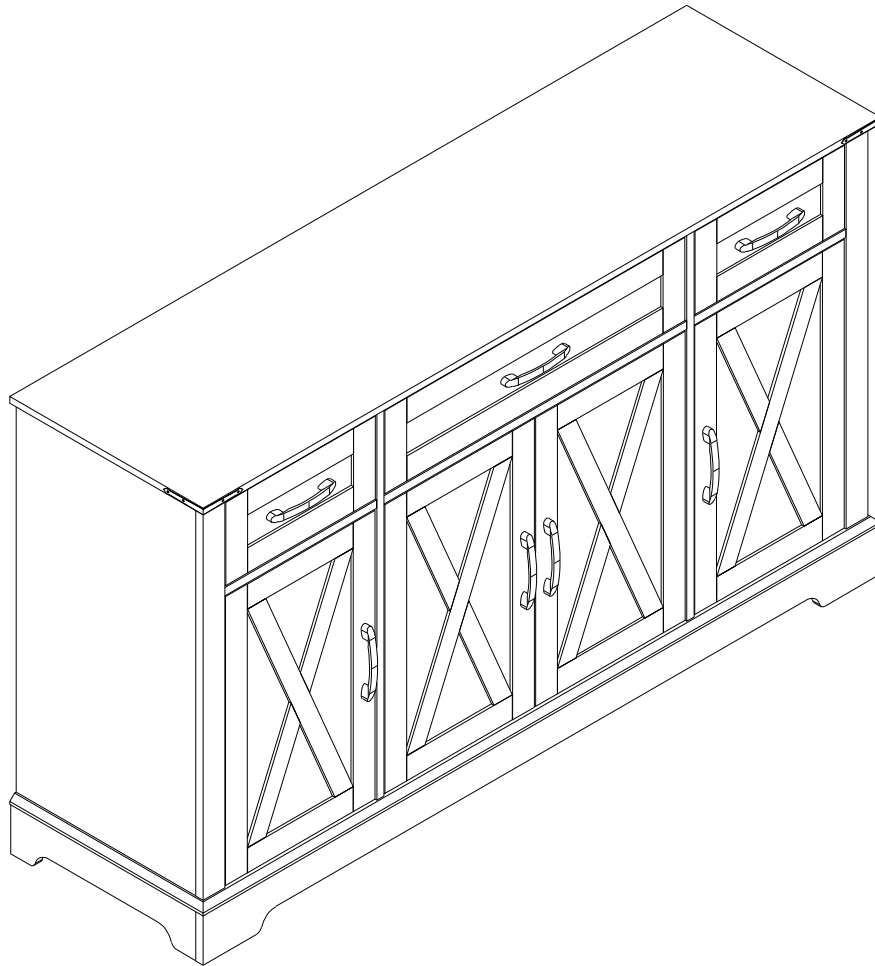

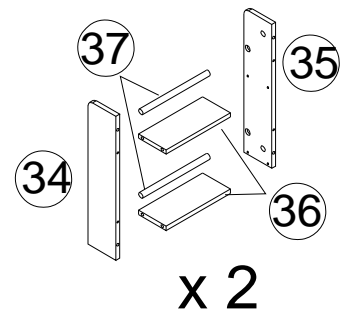

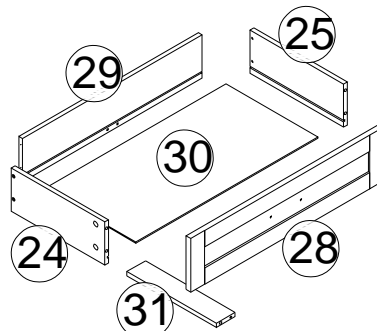
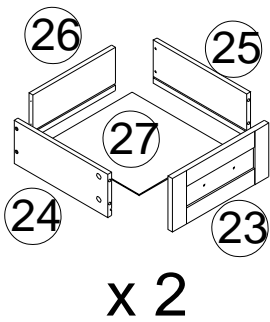
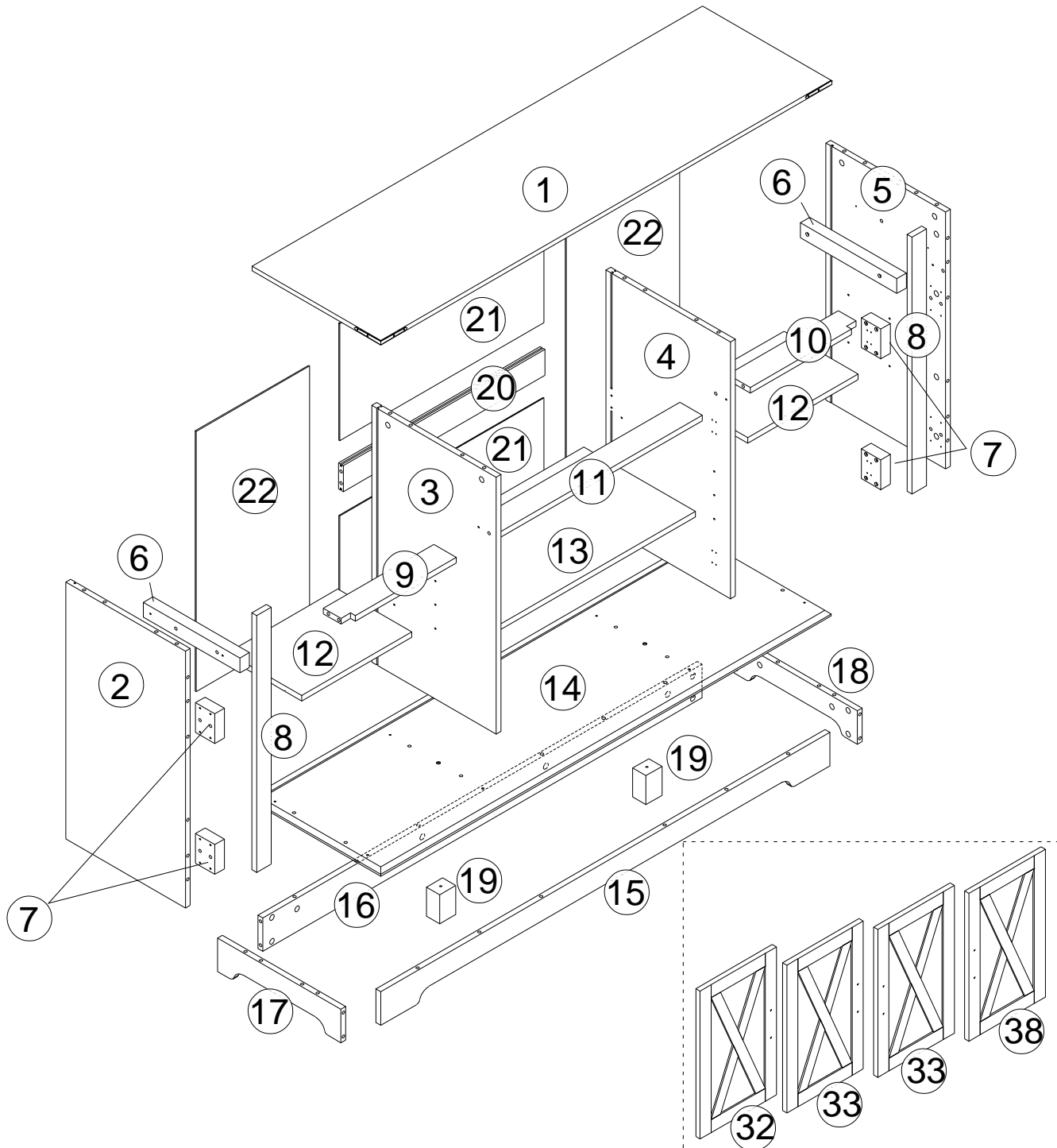





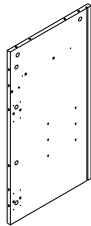

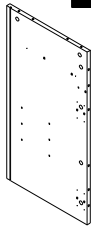
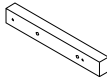
Detail View/ Vue détaillée

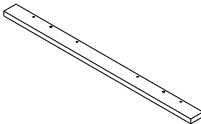
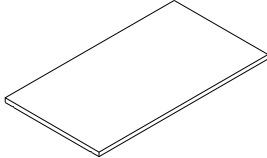

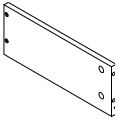
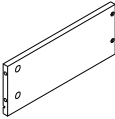
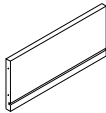
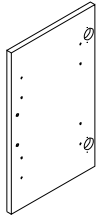
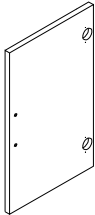
Part List / Liste des pieces

BOX1: N853P285582

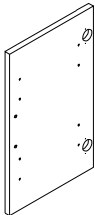
 <p>2 x1</p>	 <p>3 x1</p>	 <p>4 x1</p>	 <p>5 x1</p>
<p>Left side panel Le panneau gauche</p>	<p>Left partition La partition gauche</p>	<p>Right partition La partition droite</p>	<p>Right side panel Le panneau droite</p>
 <p>6 x2</p>	 <p>7 x4</p>	 <p>8 x2</p>	 <p>13 x1</p>
<p>Slide support Barres de support pour glissières</p>	<p>Hinge support Barres d'appui pour charnières</p>	<p>Front post Le post précédent</p>	<p>Middle shelf Panneaux de couches intermédiaires</p>
 <p>19 x2</p>	 <p>24 x3</p>	 <p>25 x3</p>	 <p>26 x2</p>
<p>Middle leg Pied au milieu</p>	<p>Drawer left side Plaque gauche du tiroir</p>	<p>Drawer right side Plateau droit du tiroir</p>	<p>Drawer back panel Panneau arrière du tiroir</p>
 <p>32 x1</p>	 <p>33 x2</p>	 <p>34 x2</p>	 <p>35 x2</p>
<p>Side door Panneau de porte latérale</p>	<p>Middle door Panneau de porte intermédiaire</p>	<p>Rack right side Panneau gauche de l'étagère</p>	<p>Rack left side Plateau droit de l'étagère</p>
 <p>36 x4</p>	 <p>38 x1</p>	<p>Hardware List Liste du matériel</p>	
<p>Rack shelf Lamelles pour étagères</p>	<p>Side door Panneau de porte latérale</p>		





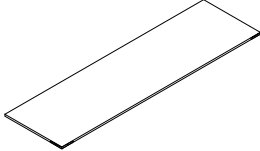
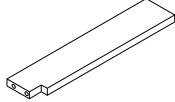
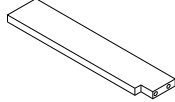
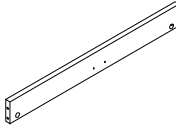
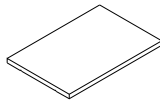
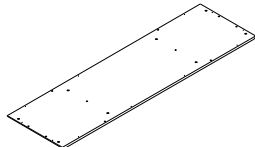
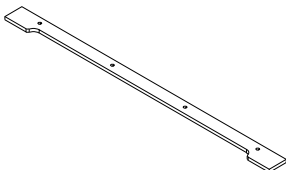
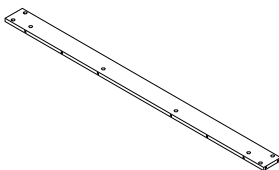
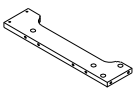
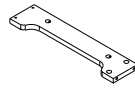
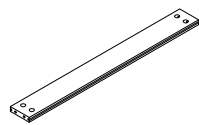
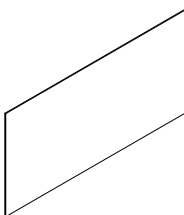
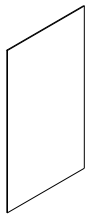
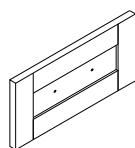
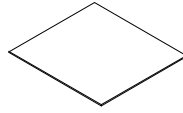
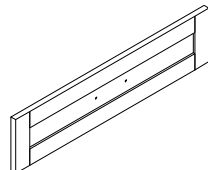
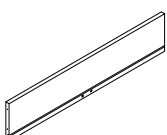
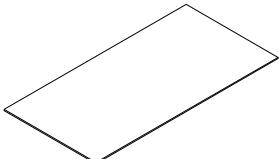
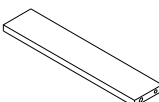
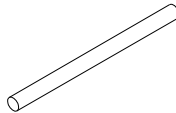







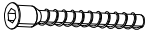

Part List / Liste des pieces

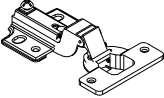
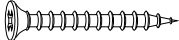
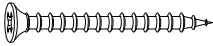
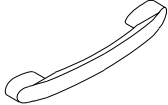
BOX2: N853P285583

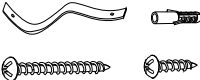
<p>1 x1</p> 	<p>9 x1</p> 	<p>10 x1</p> 	<p>11 x1</p> 
<p>Top panel Panneau supérieur</p>	<p>Front left crossbar Barre transversale à gauche</p>	<p>Front right crossbar Barre à droite</p>	<p>Front middle crossbar Barre transversale au milieu</p>
<p>12 x2</p> 	<p>14 x1</p> 	<p>15 x1</p> 	<p>16 x1</p> 
<p>Side shelf Panneau de couche latérale</p>	<p>Bottom panel Panneau inférieur</p>	<p>Front apron Panneau avant et inférieur</p>	<p>Rear apron Plaque inférieure arrière</p>
<p>17 x1</p> 	<p>18 x1</p> 	<p>20 x1</p> 	<p>21 x2</p> 
<p>Left apron Panneau inférieur gauche</p>	<p>Right apron Panneau inférieur droit</p>	<p>Back crossbar Barre transversale arrière</p>	<p>Middle back panel Plaque arrière au milieu</p>
<p>22 x2</p> 	<p>23 x2</p> 	<p>27 x2</p> 	<p>28 x1</p> 
<p>Side back panel Panneau arrière latéral</p>	<p>Small drawer front Petite plaque frontale de tiroirs</p>	<p>Small drawer bottom panel Plateau de base pour petits tiroirs</p>	<p>Big drawer front Grande plaque frontale de tiroirs</p>
<p>29 x1</p> 	<p>30 x1</p> 	<p>31 x1</p> 	<p>37 x4</p> 
<p>Big drawer back panel Grande plaque arrière tiroir</p>	<p>Big drawer bottom panel Grande plaque de base tiroir</p>	<p>Drawer support Soutenir la barre</p>	<p>Rack rail Clôture</p>

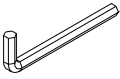
Hardware List / Liste du

N853P285582

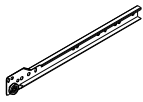
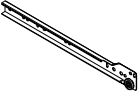
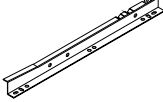
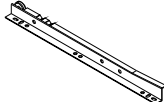
<p>A x84 +2 Φ6x35mm</p> 	<p>B x84 +2 Φ15x9mm</p> 	<p>C x48 +2 Φ8x30mm</p> 	<p>D x84 +2 Φ3.5x14mm</p> 	<p>E x10 +1 Φ7x45mm</p> 
<p>Cam Bolt Boulon à came</p>	<p>Cam Nut Écrou à came</p>	<p>Wood dowel Cheville en bois</p>	<p>Screw Vis à bois</p>	<p>Screw Vis à bois</p>
<p>F x12 +1 Φ5x13mm</p> 	<p>G x 8</p> 	<p>H x12 +1 Φ4x30mm</p> 	<p>I x20 +1 Φ4x40mm</p> 	<p>J x 7</p> 
<p>Shelf Support Support d'étagère</p>	<p>Hinge Charnière</p>	<p>Screw Vis à bois</p>	<p>Screw Vis à bois</p>	<p>Handle Poignée</p>
<p>K x8 +1 M4x16mm</p> 	<p>L x6 +1 M4x10mm</p> 	<p>M x 2 Φ4x30mm Φ4x14mm</p> 	<p>N x 2</p> 	<p>O x24 +1 Φ3x14mm</p> 
<p>Bolt Vis</p>	<p>Bolt Vis</p>	<p>Anti-lip device Dispositif anti-renversement</p>	<p>Adjustable leg Pieds de réglage</p>	<p>Single Plastic Cap Bouchon en plastique simple</p>
<p>P x 1 M4</p> 	<p>Q x 3</p> 	<p>R x6 +1 Φ3x12mm</p> 	<p>S x8 +1 Φ6x30mm</p> 	
<p>Allen wrench Clé Allen</p>	<p>Door Stopper Butoir de porte</p>	<p>Screw Vis à bois</p>	<p>Wood dowel Cheville en bois</p>	
<p>CL x 3 300mmL</p> 	<p>CR x 3 300mmL</p> 	<p>DL x 3 300mmL</p> 	<p>DR x 3 300mmL</p> 	
<p>Slide Glissière</p>	<p>Slide Glissière</p>	<p>Slide Glissière</p>	<p>Slide Glissière</p>	

ASSEMBLY TOOLS REQUIRED (NOT INCLUDED)
OUTILS D'ASSEMBLAGE REQUIS (NON INCLUS)

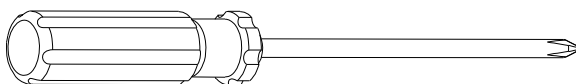

PLEASE BE CAREFUL DO NOT DAMAGE THE HOLE POSITION WHEN YOU USE
POWER TOOLS !
FAITES ATTENTION À NE PAS ENDOMMAGER LA POSITION DE MAINTIEN LORSQUE
VOUS UTILISEZ DES OUTILS ÉLECTRIQUES !

STEP 1 / ETAPE 1:

x2

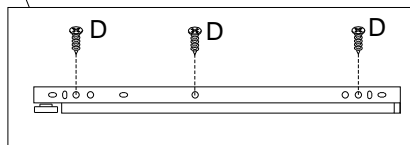
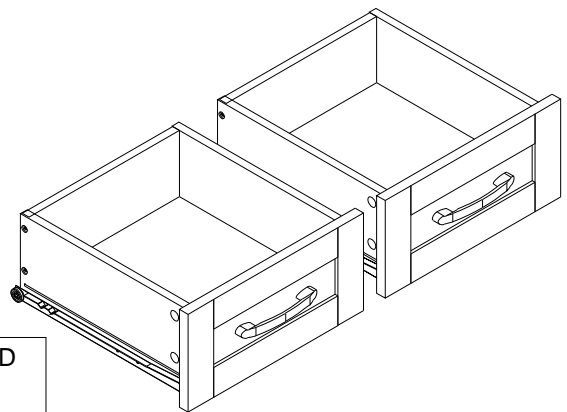
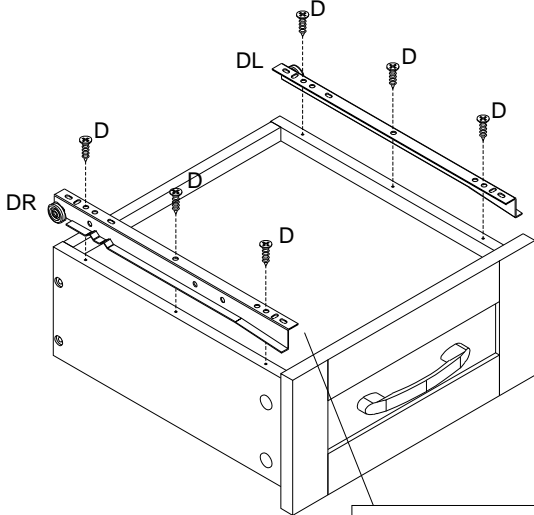
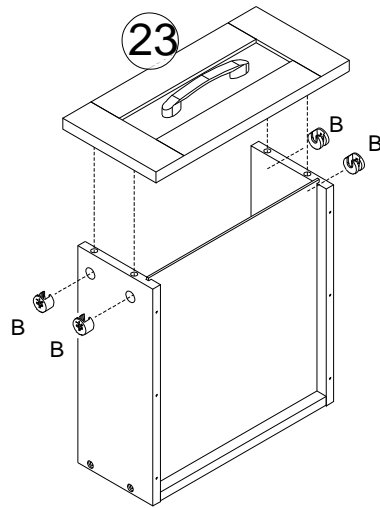
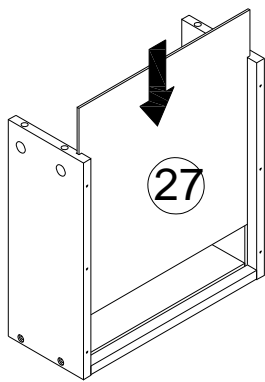
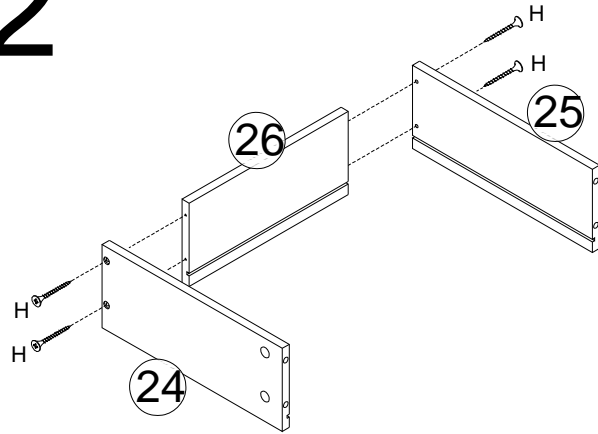
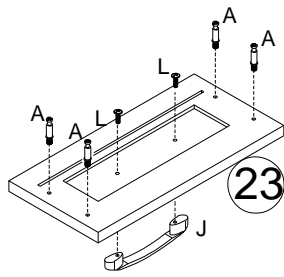

DL

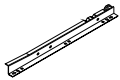

x 2

DR

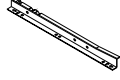

x 2

A

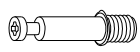

x 8

B



x 8

D



x 12

H

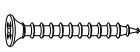

x 8

J



x 2

L



x 4

STEP 2 / ETAPE 2:

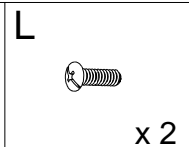
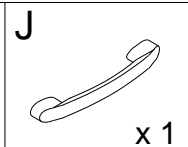
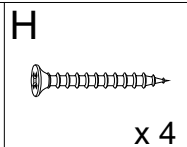
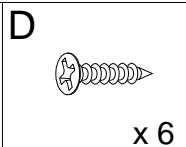
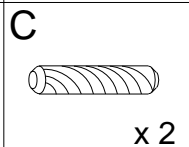
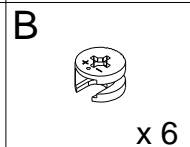
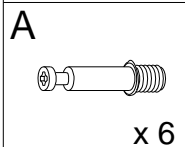
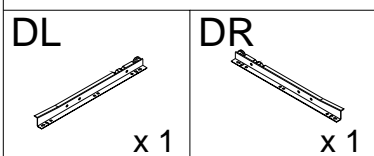
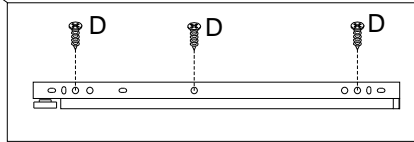
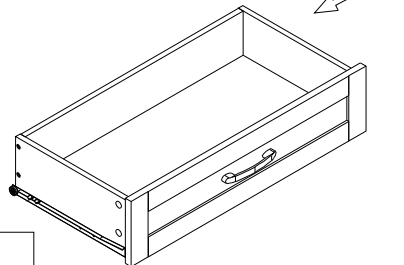
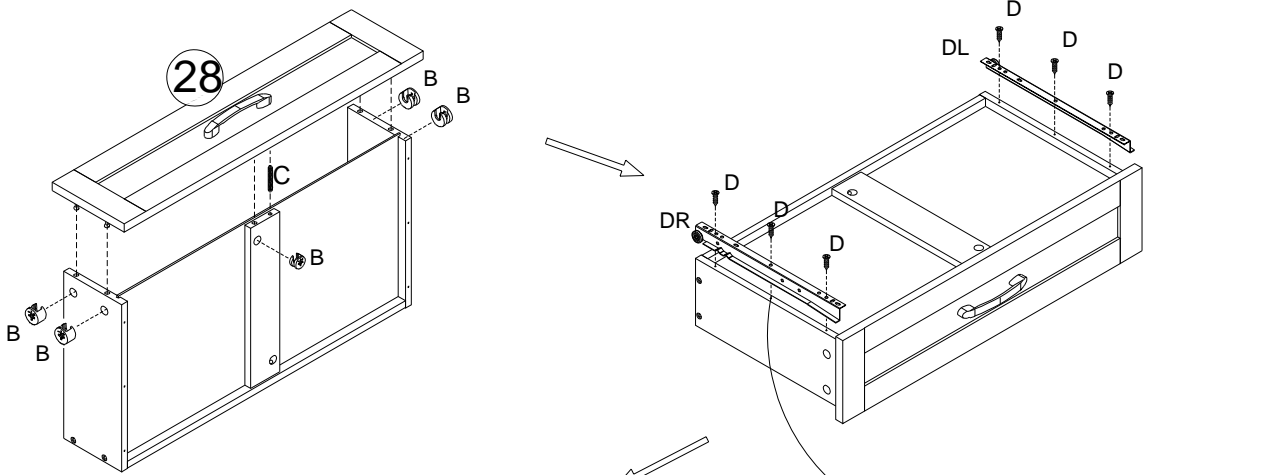
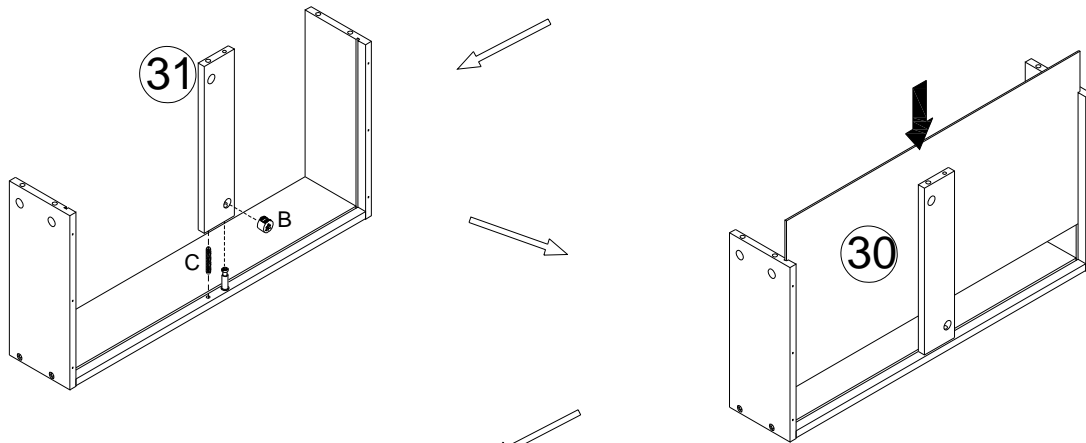
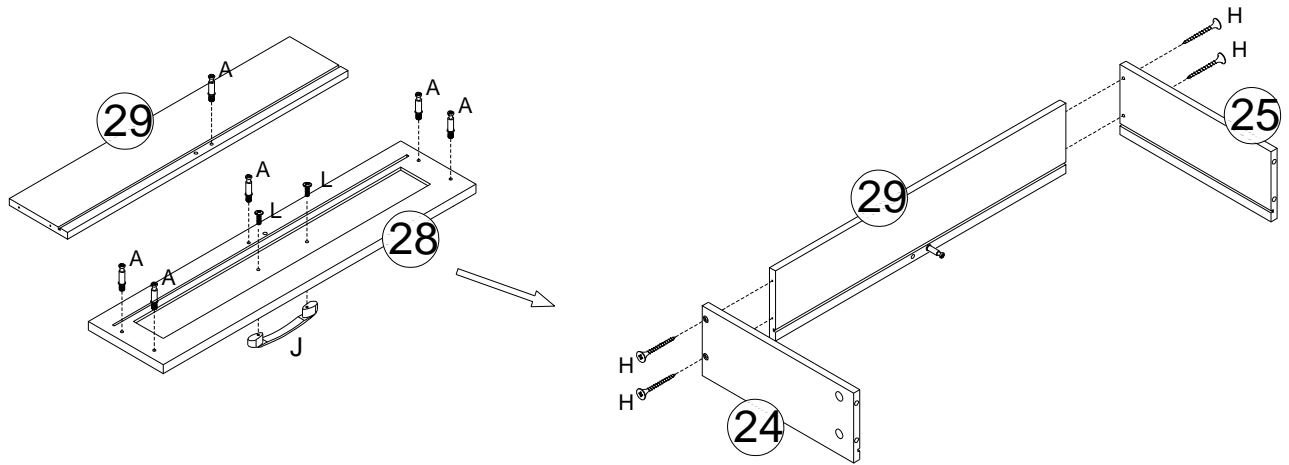

STEP 3 / ÉTAPE 3:

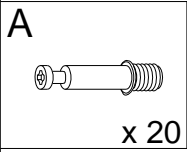
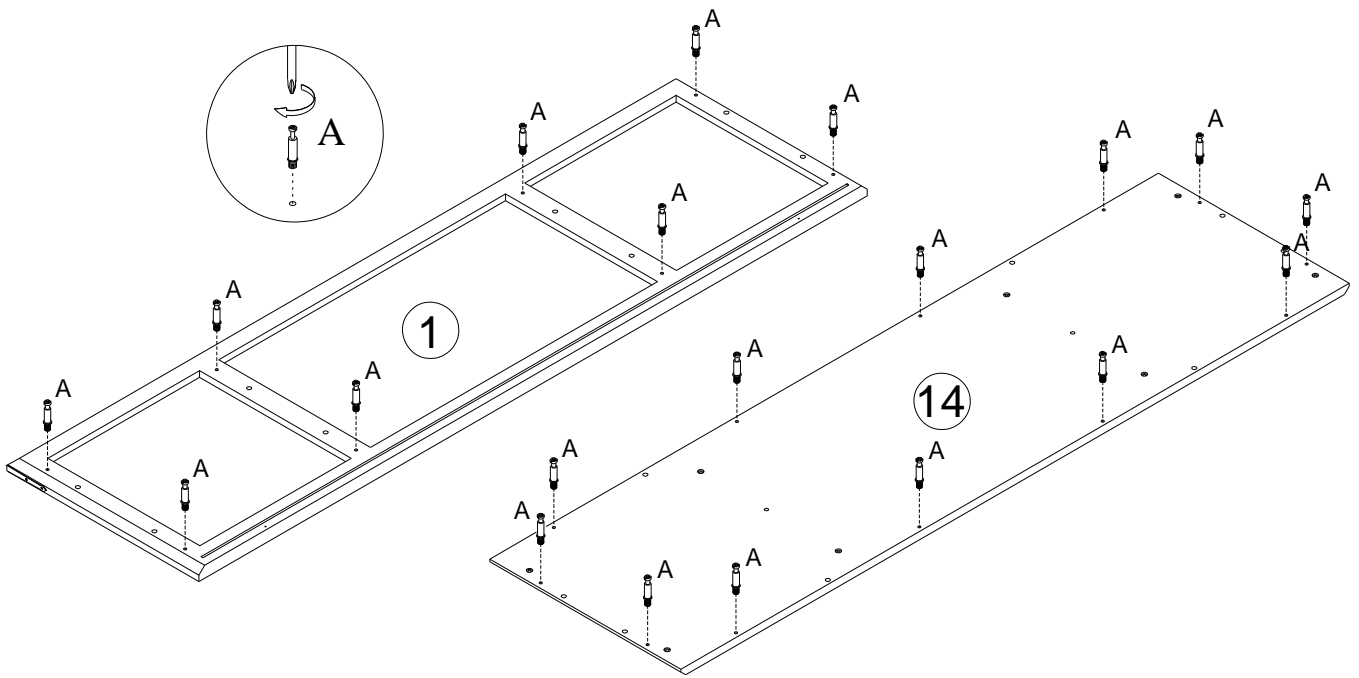

STEP 4 / ÉTAPE 4:

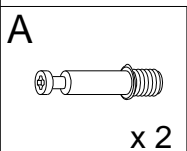
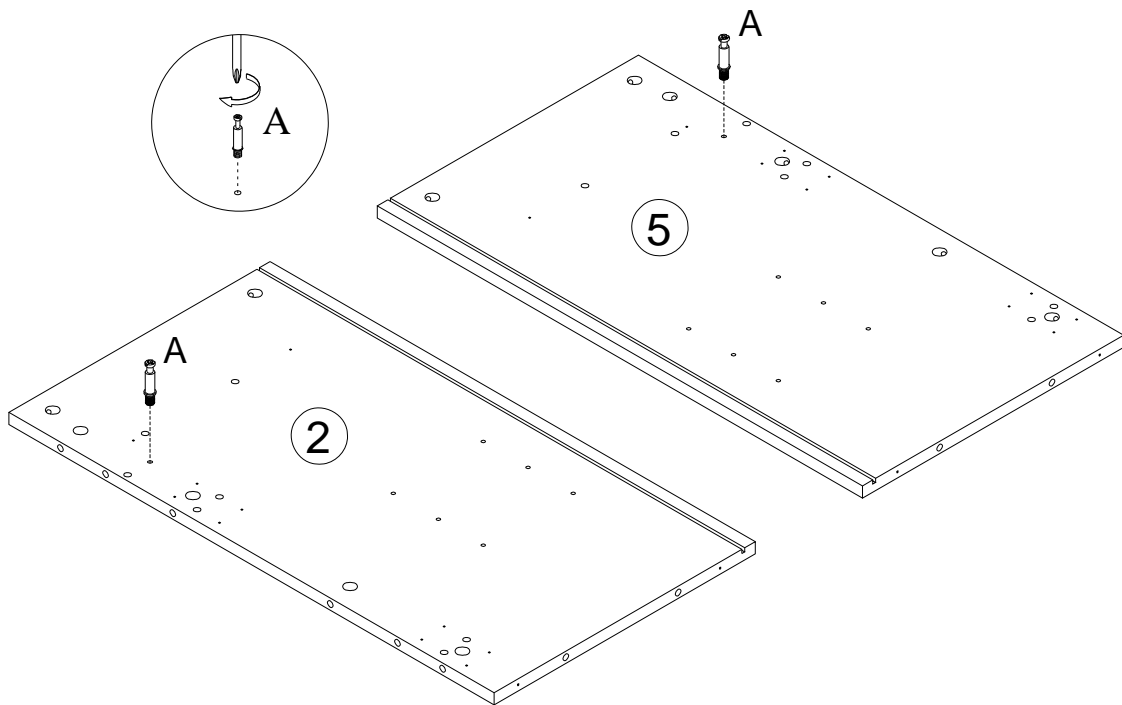

STEP 5 / ÉTAPE 5:

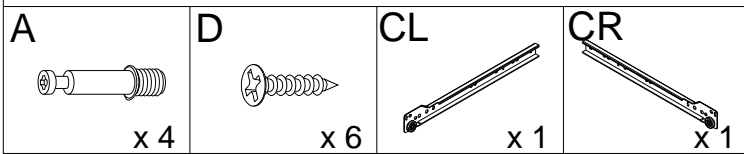
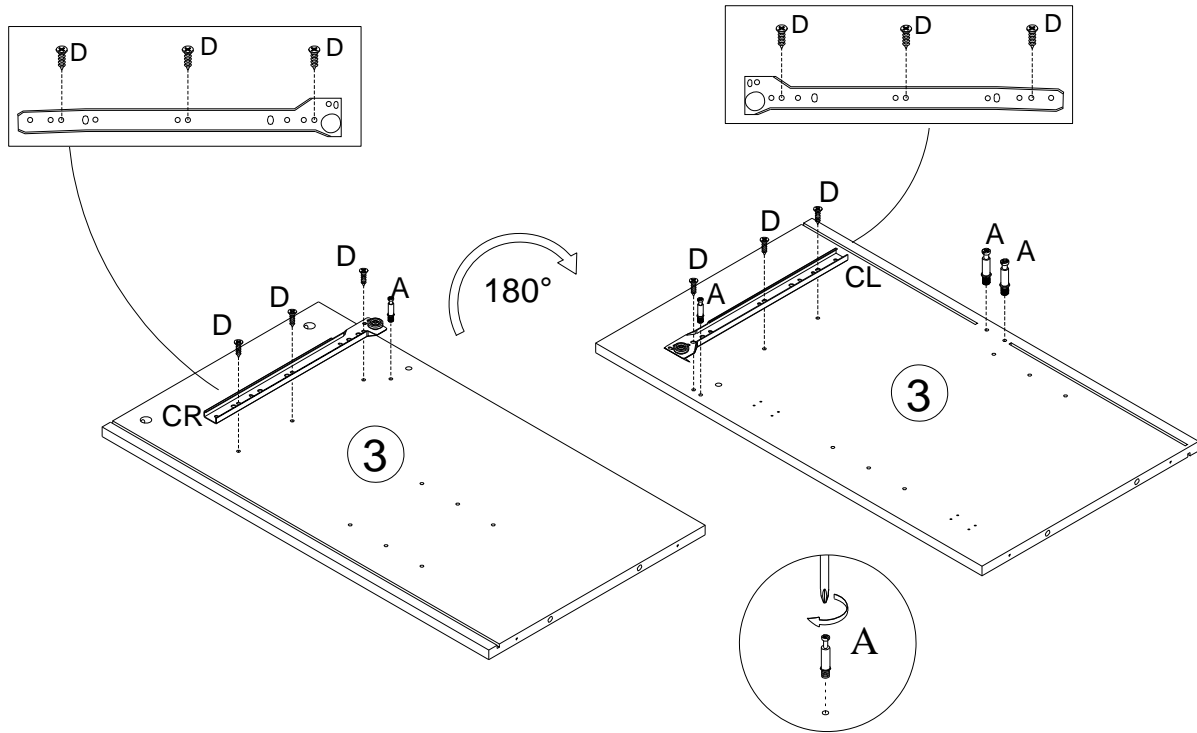

STEP 6 / ÉTAPE 6:

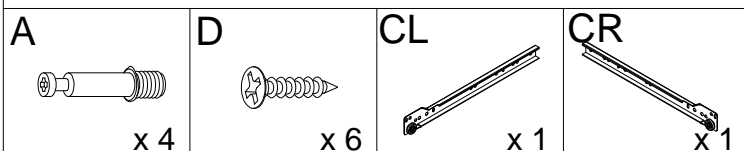
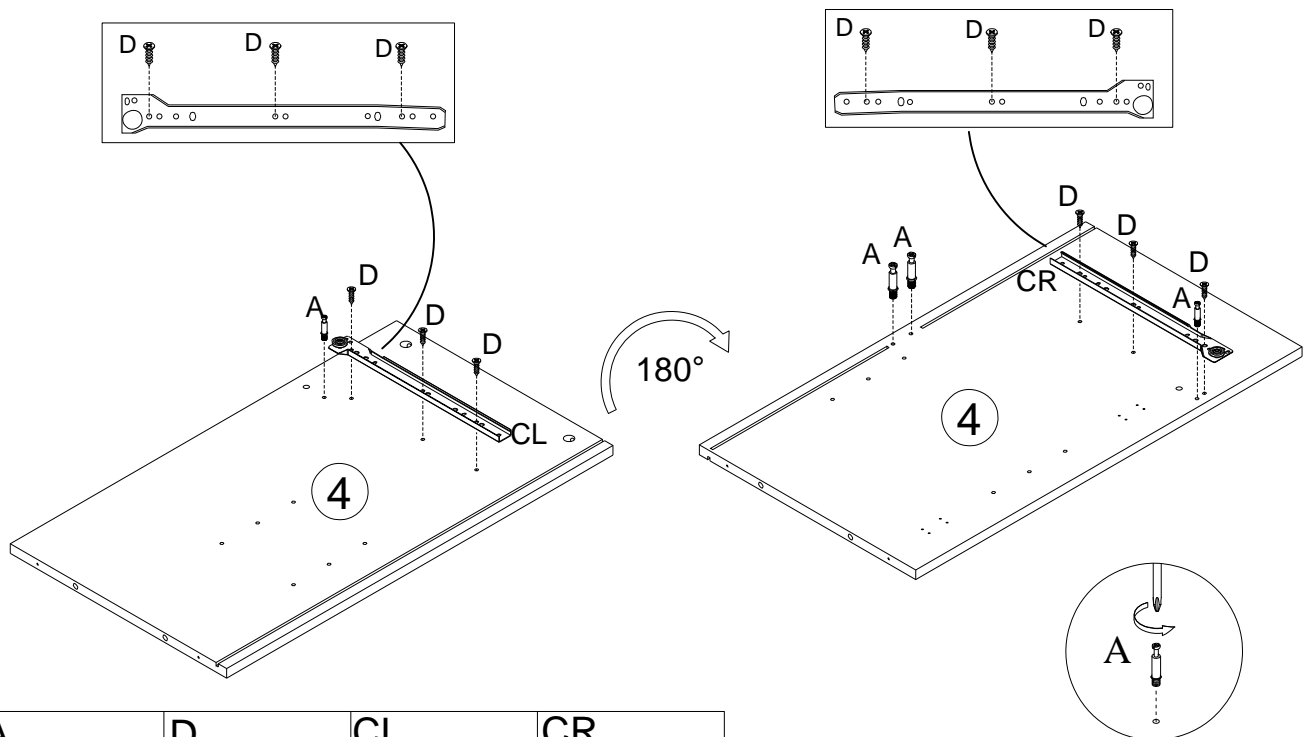

STEP 7 / ÉTAPE 7:

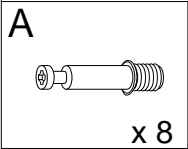
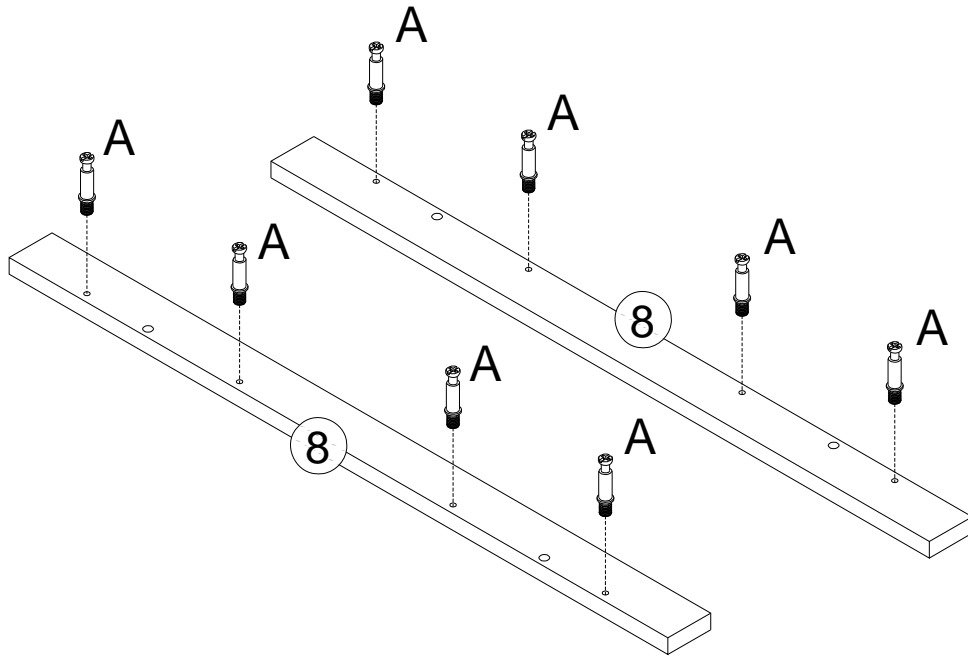

STEP 8 / ÉTAPE 8:

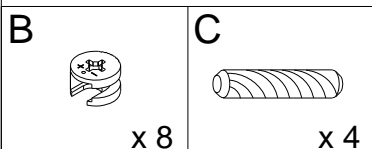
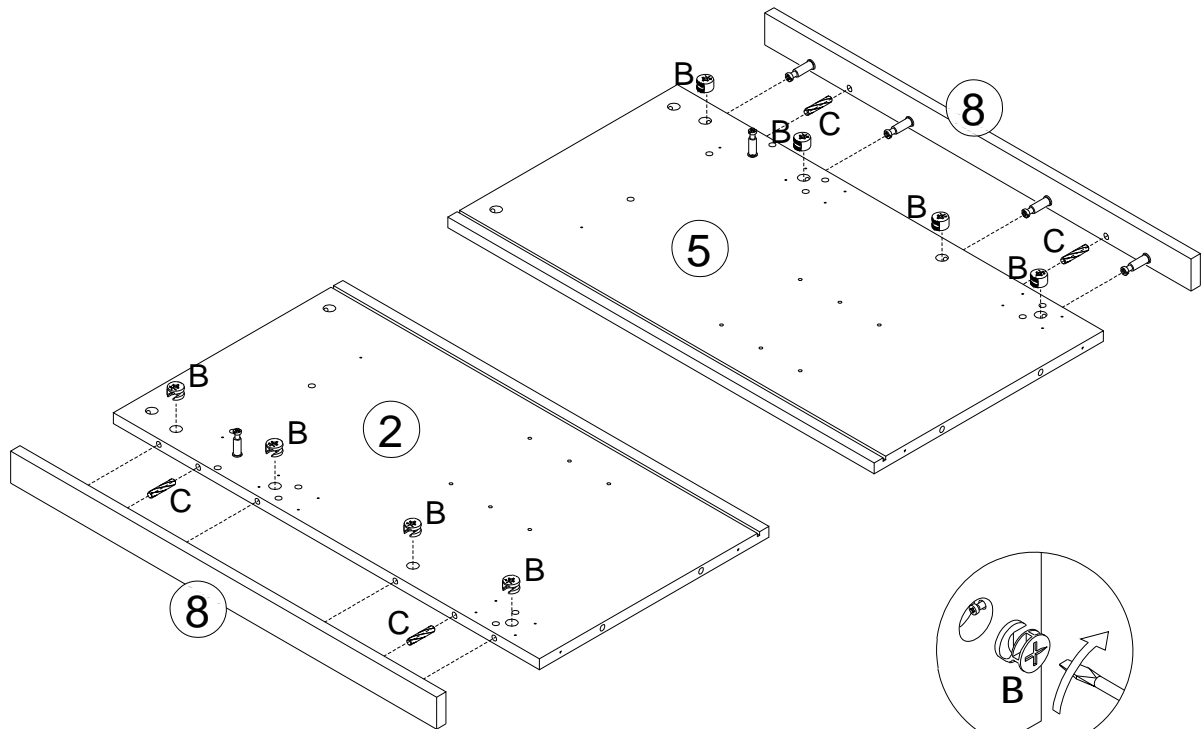

STEP 9 / ÉTAPE 9:

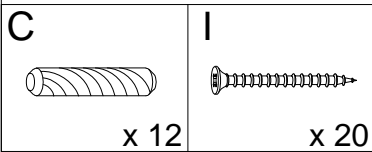
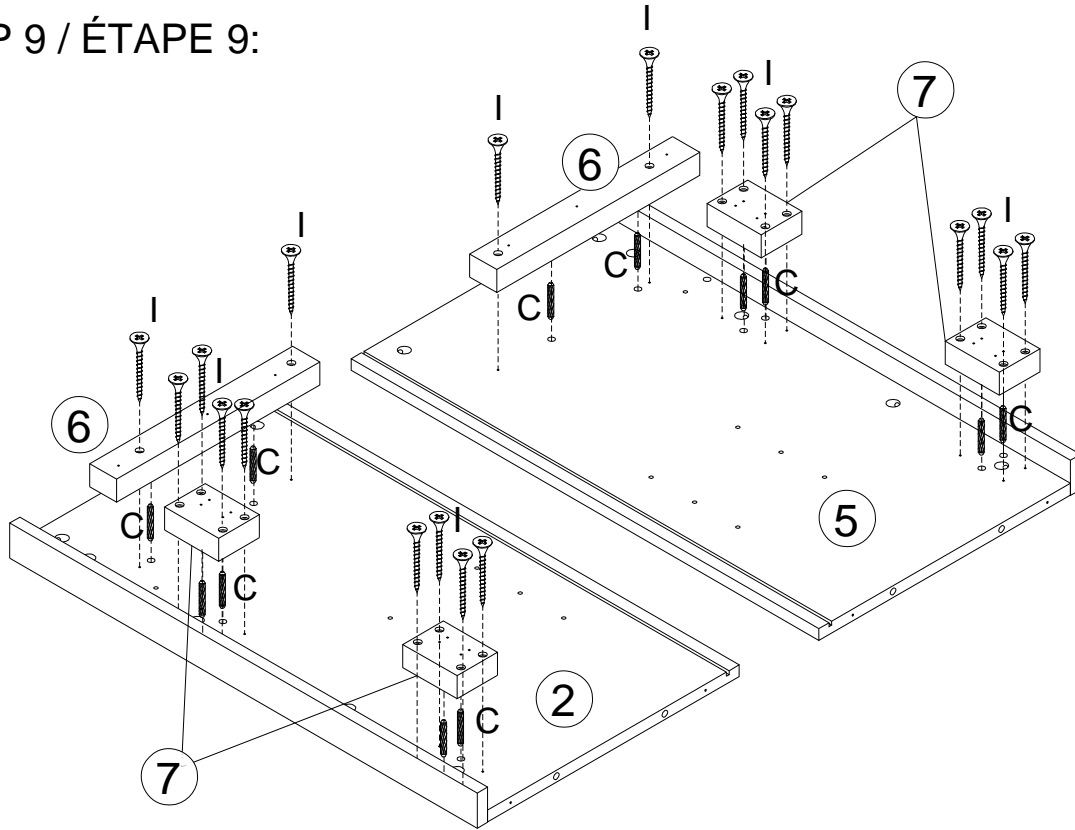

STEP 10 / ÉTAPE 10:

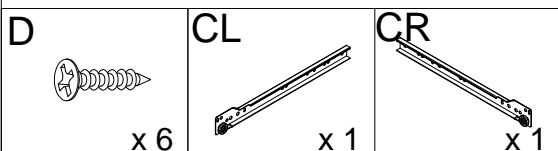
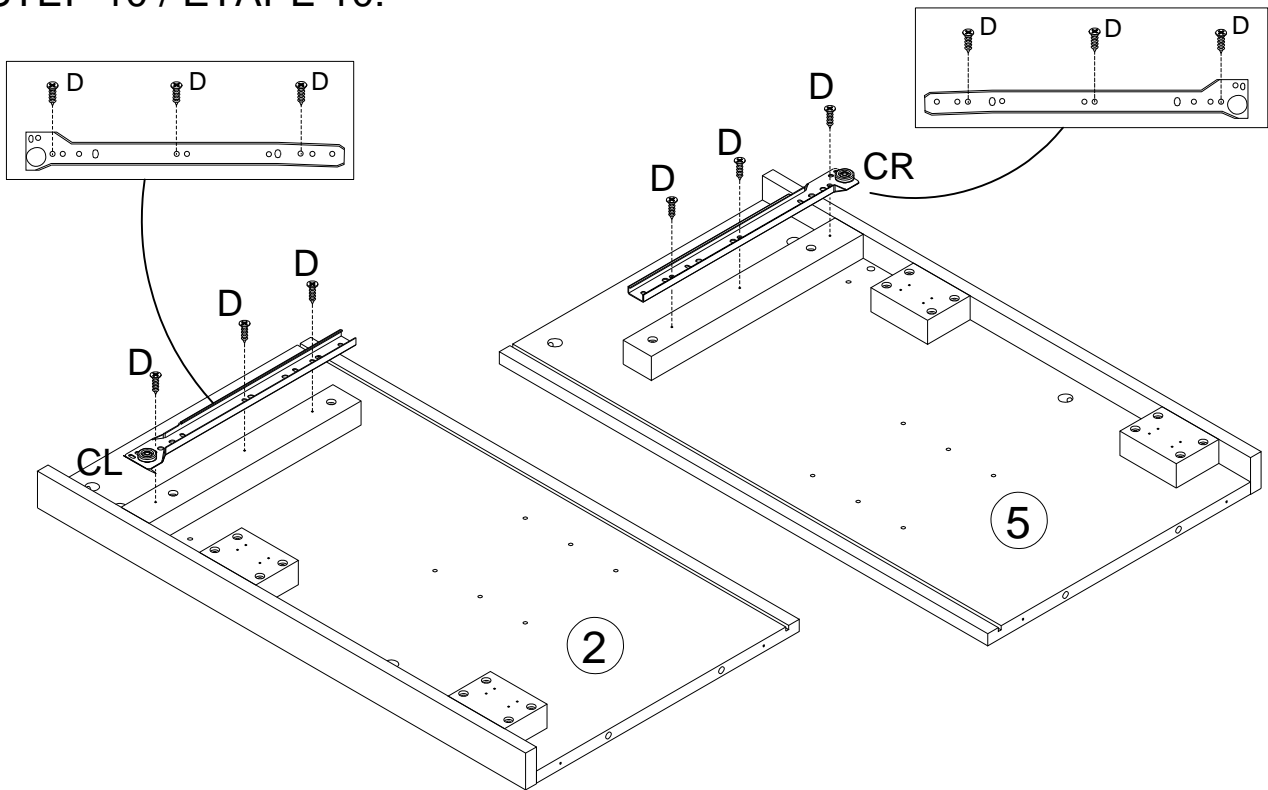

STEP 11 / ÉTAPE 11:

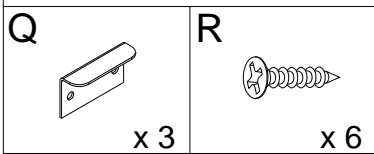
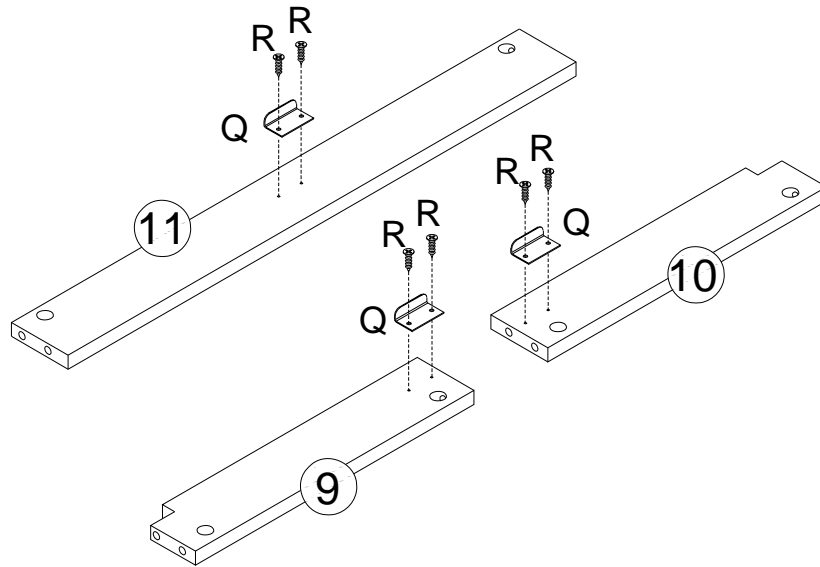

STEP 12 / ÉTAPE 12:

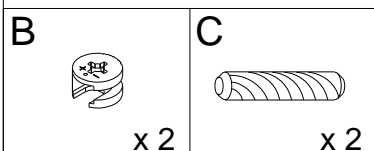
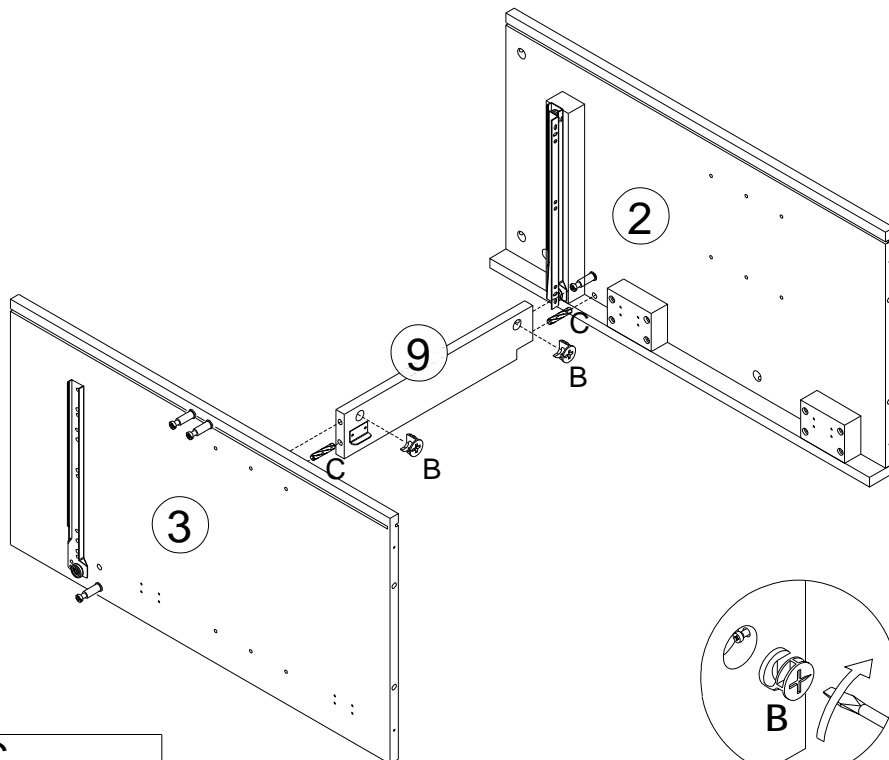

STEP 13 / ÉTAPE 13:

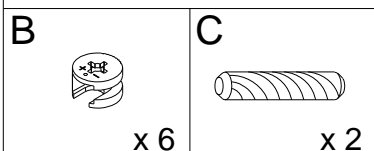
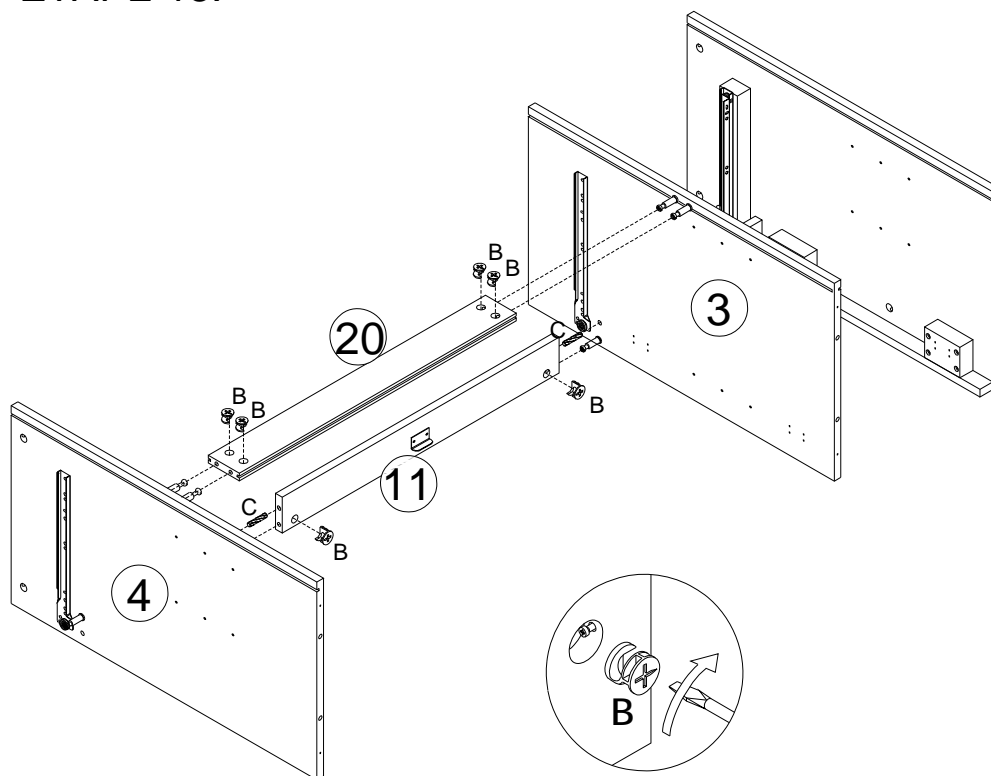

STEP 14 / ÉTAPE 14:

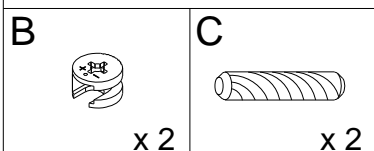
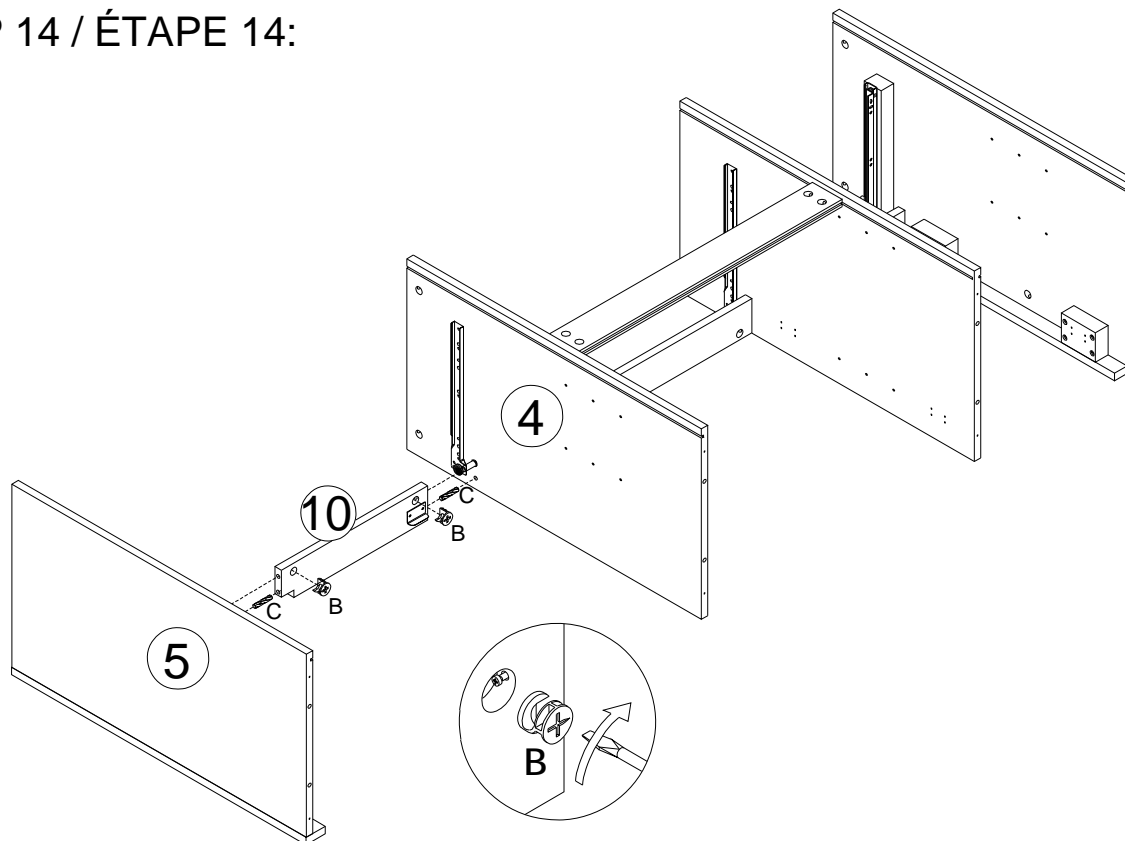

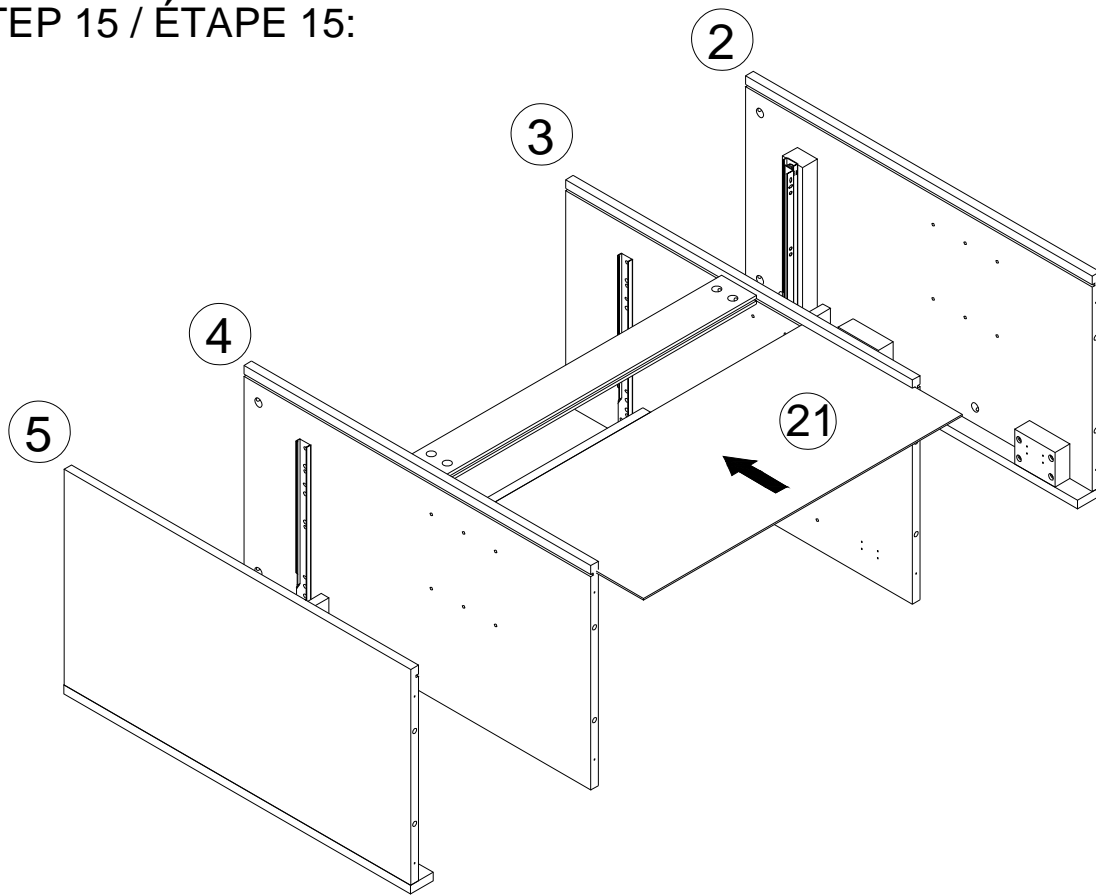

STEP 15 / ÉTAPE 15:

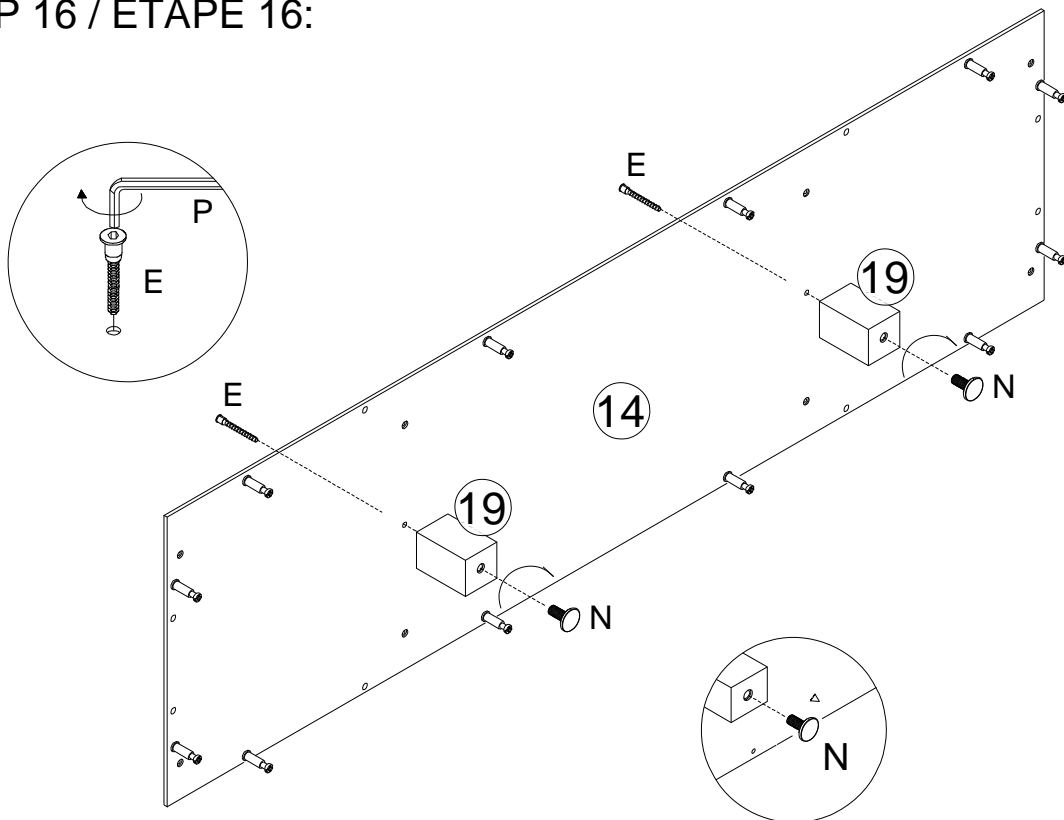

STEP 16 / ÉTAPE 16:

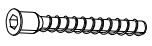

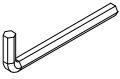
E  x 2	N  x 2	P  x 1
--	--	--

STEP 17 / ÉTAPE 17:

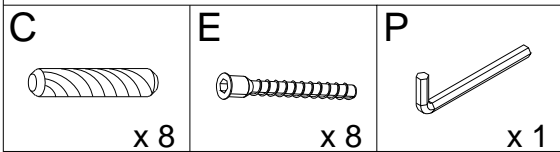
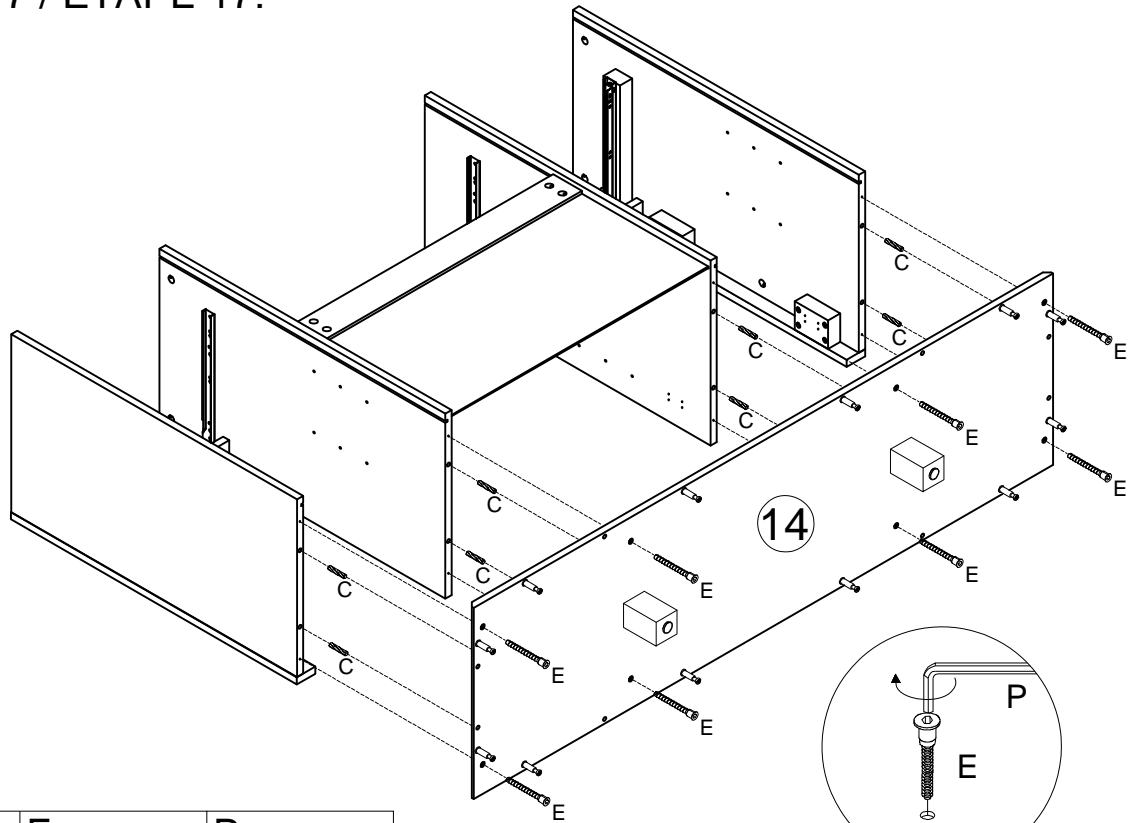

STEP 18 / ÉTAPE 18:

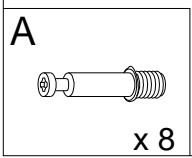
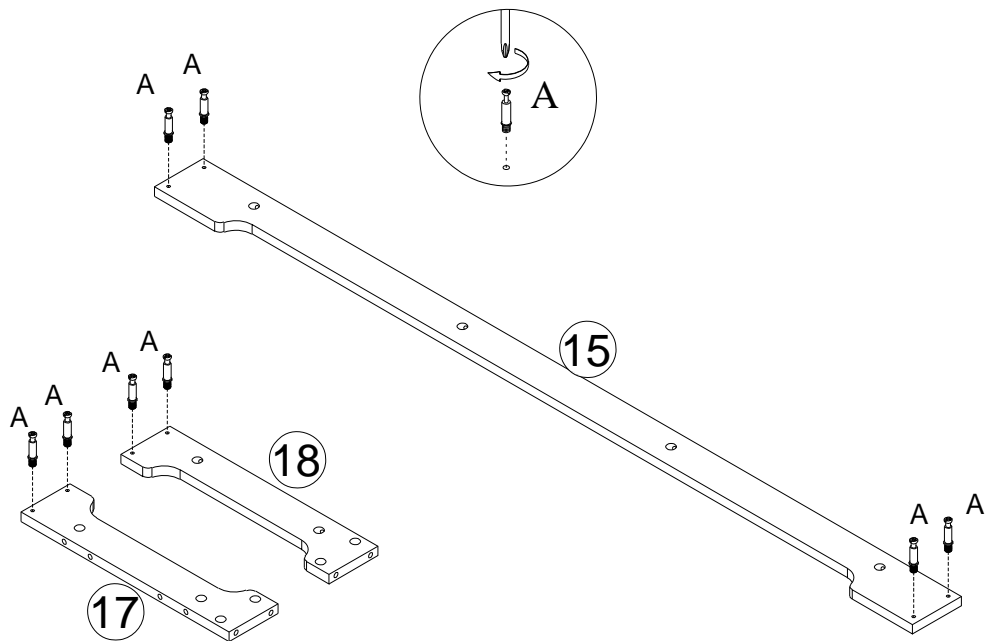

STEP 19 / ÉTAPE 19:

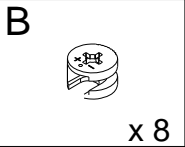
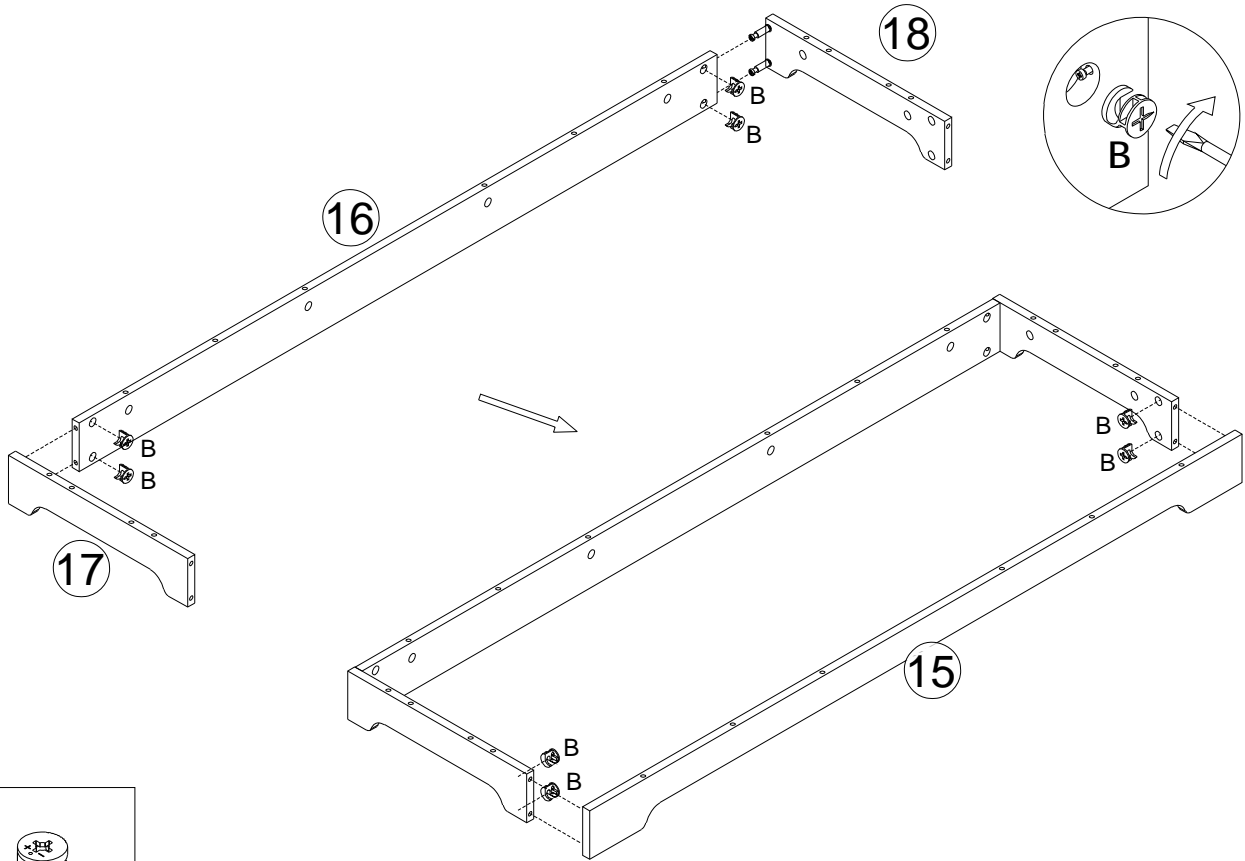

STEP 20 / ÉTAPE 20:

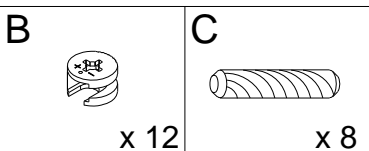
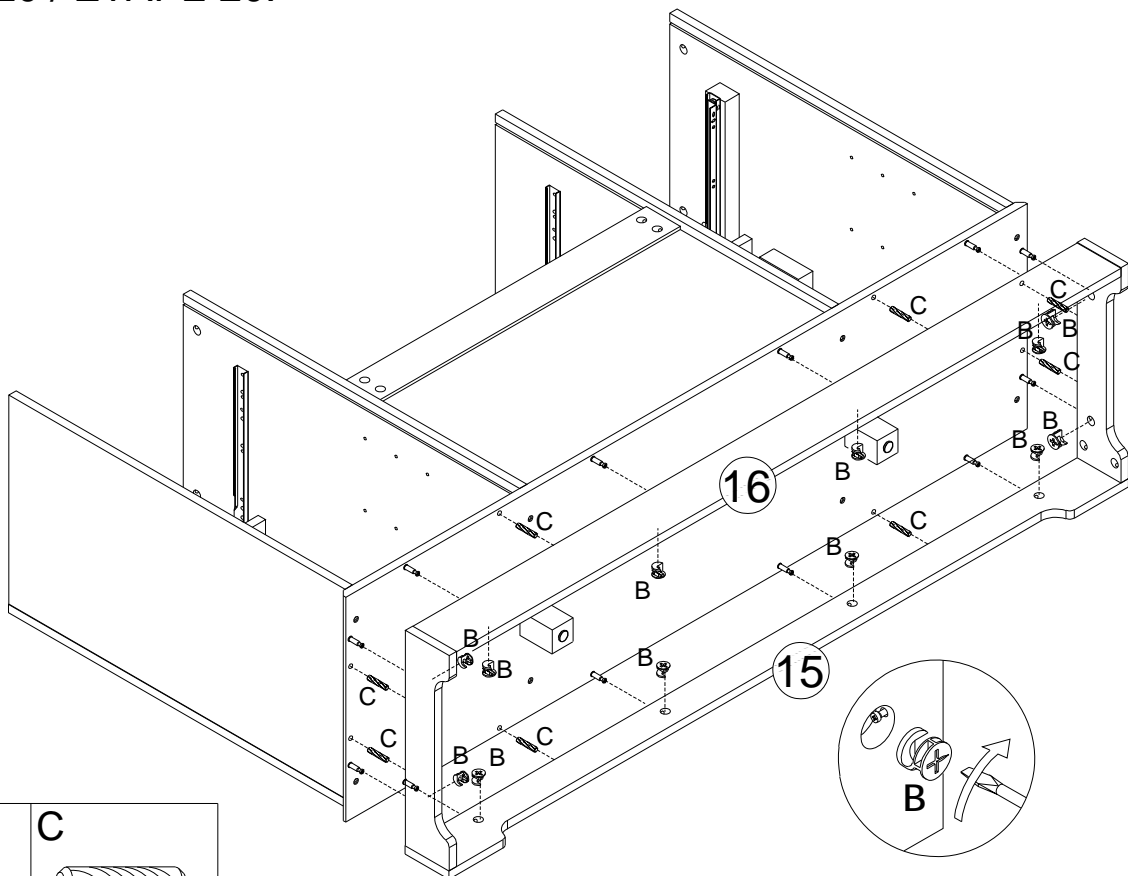

STEP 21 / ÉTAPE 21:

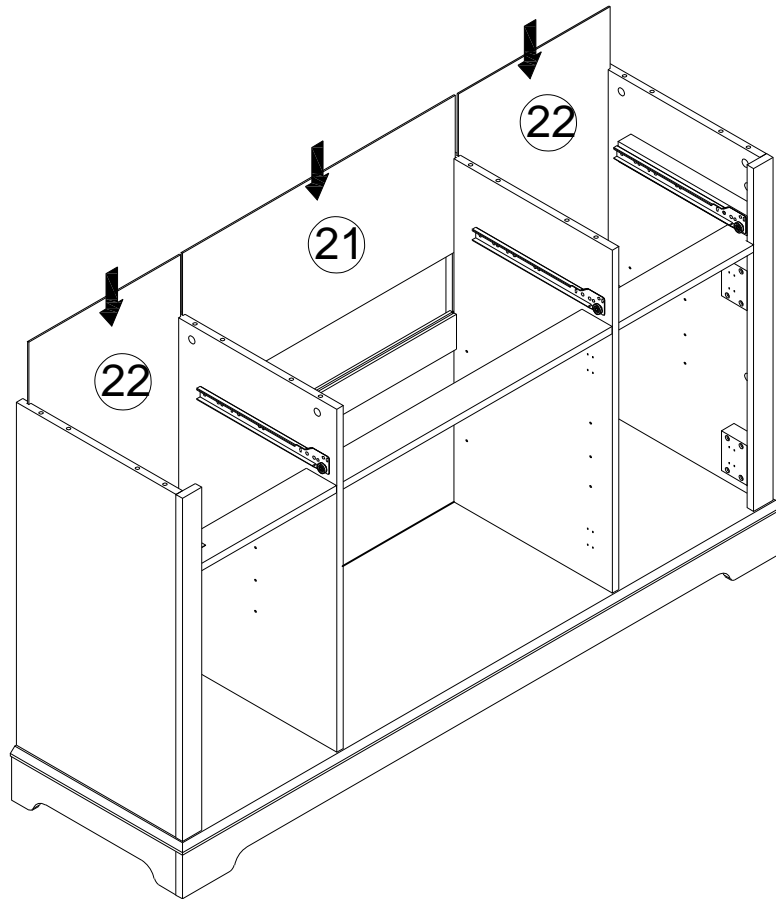

STEP 22 / ÉTAPE 22:

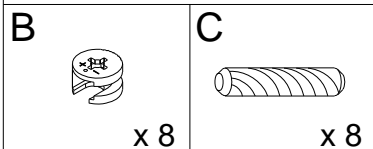
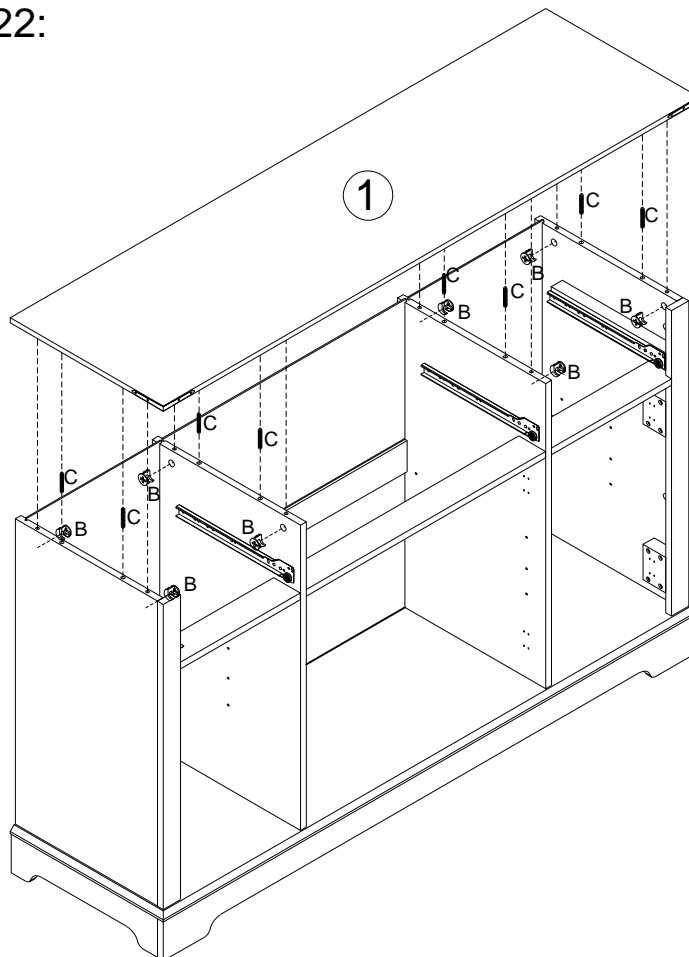

STEP 23 / ÉTAPE 23:

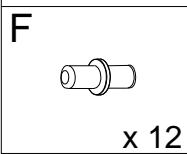
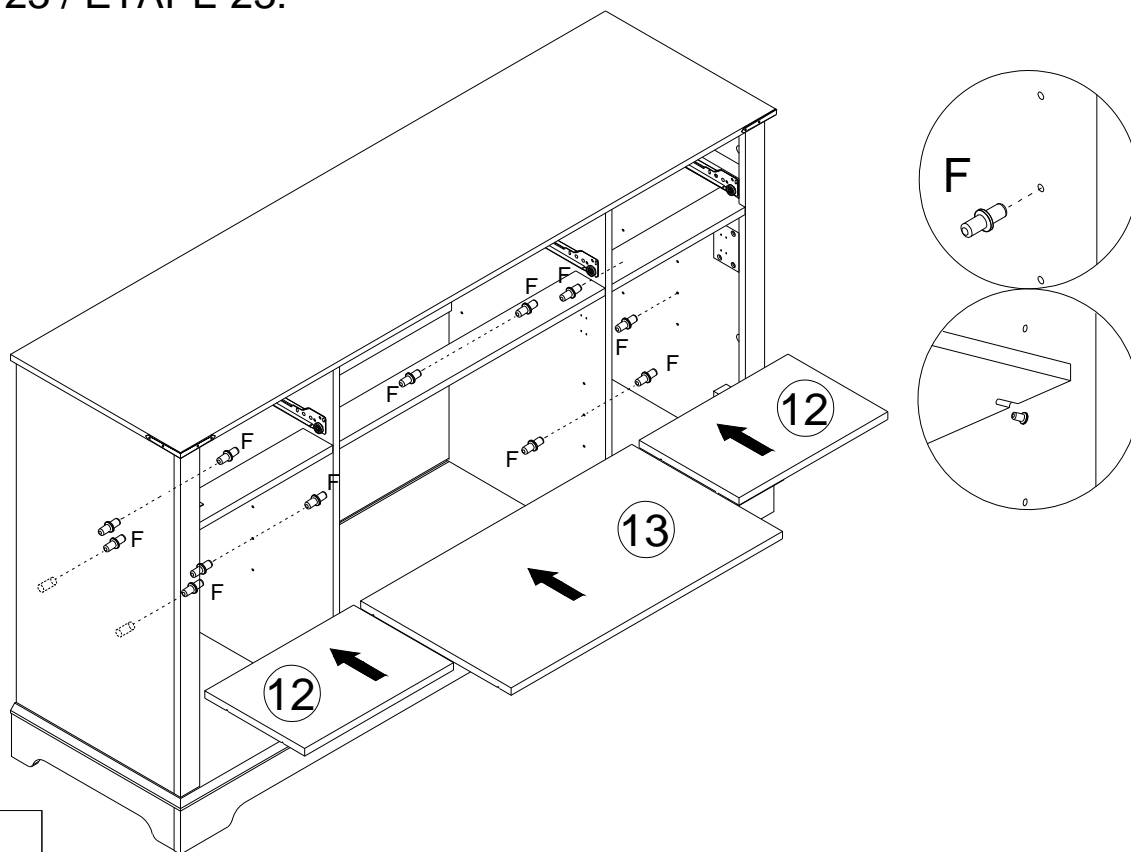

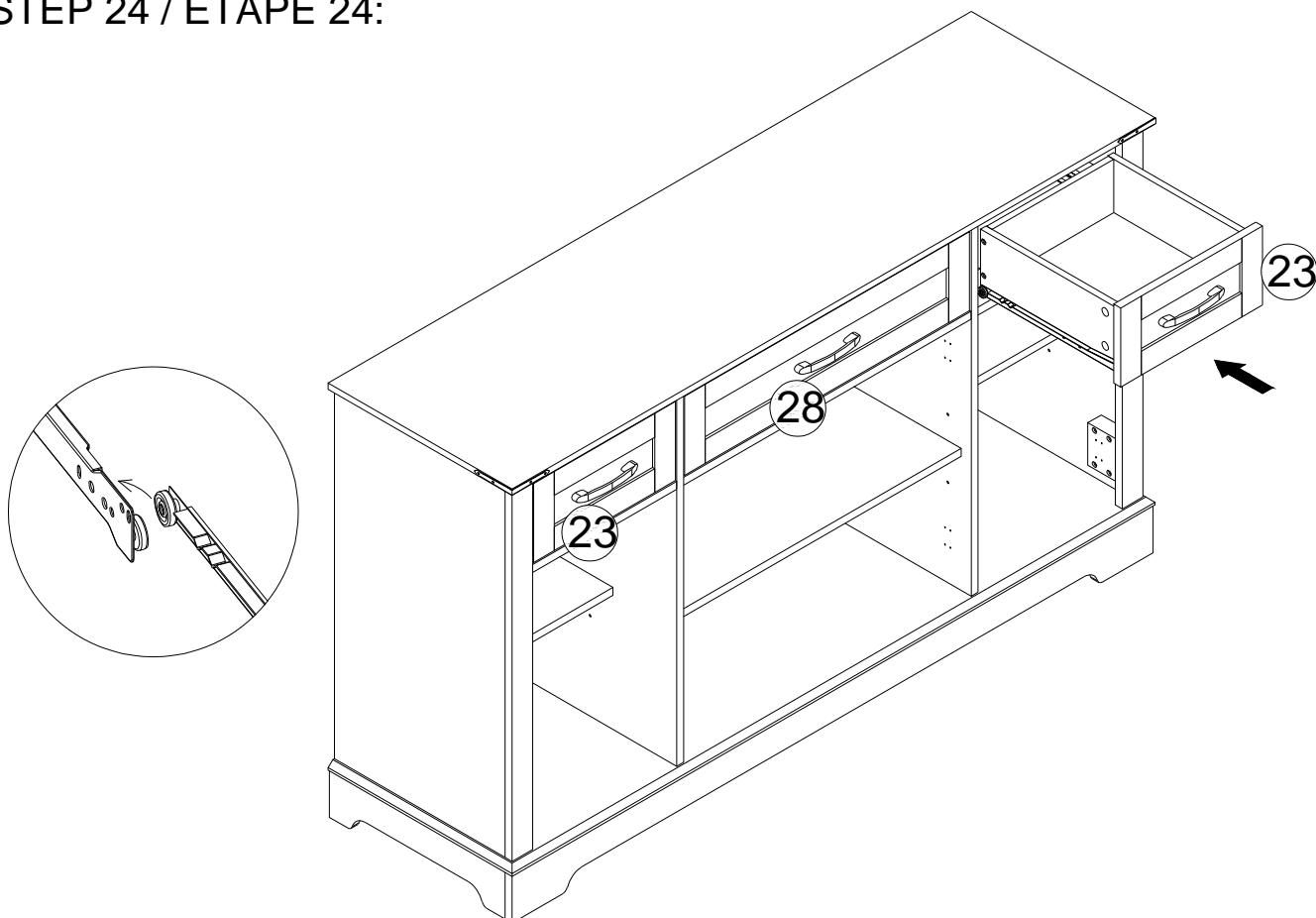

STEP 24 / ÉTAPE 24:



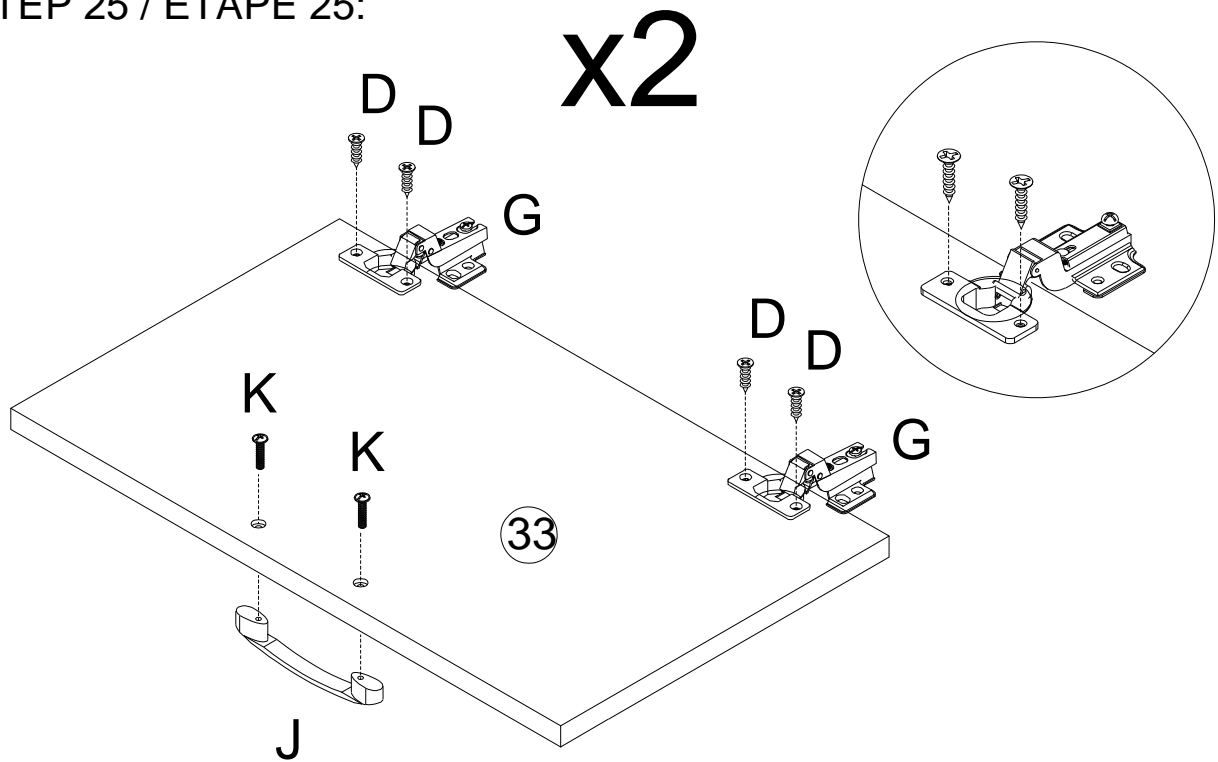

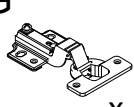
STEP 25 / ÉTAPE 25:

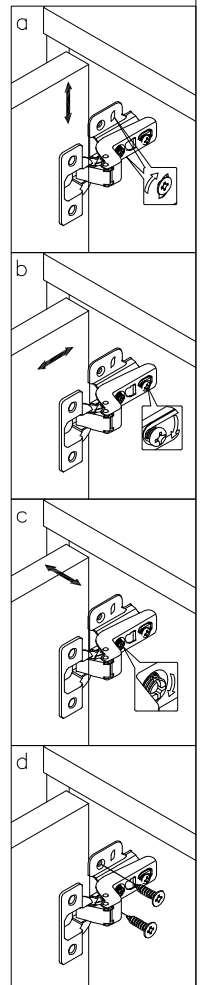
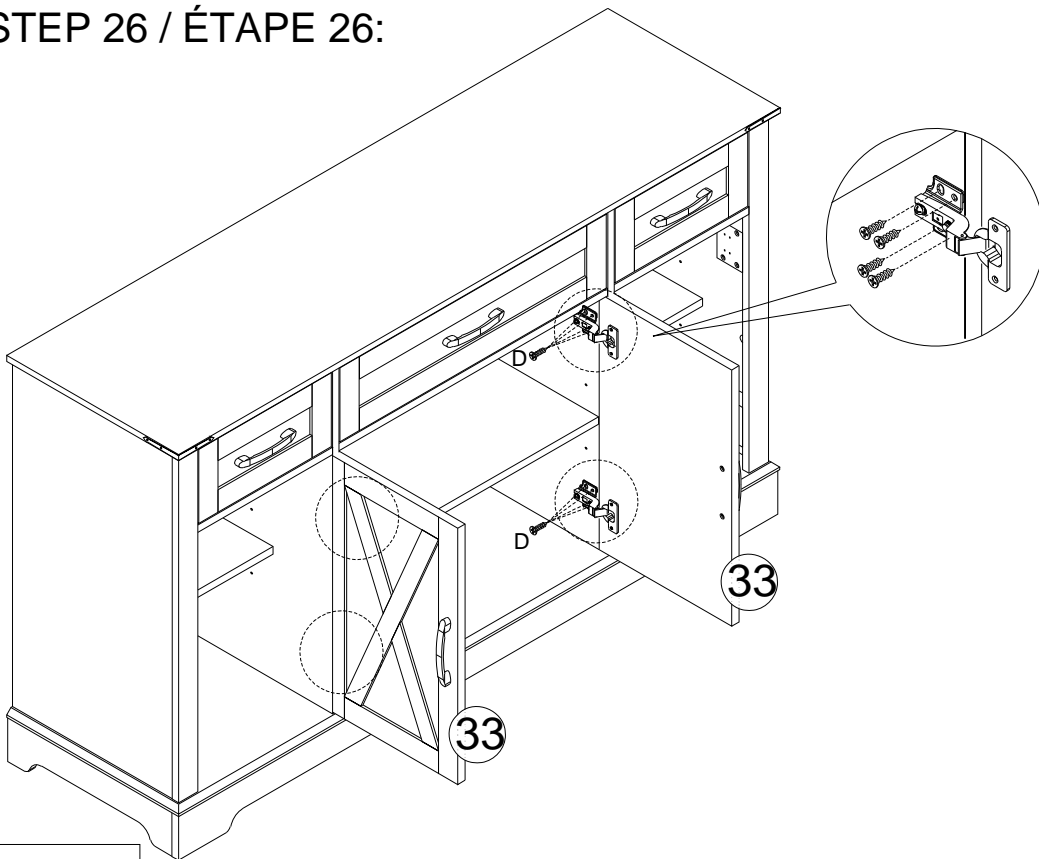

<p>D</p>  <p>x 8</p>	<p>G</p>  <p>x 4</p>	<p>J</p>  <p>x 2</p>	<p>K</p>  <p>x 4</p>
--	---	--	--

STEP 26 / ÉTAPE 26:



<p>D</p>  <p>x 16</p>

STEP 27 / ÉTAPE 27:

x2

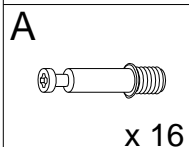
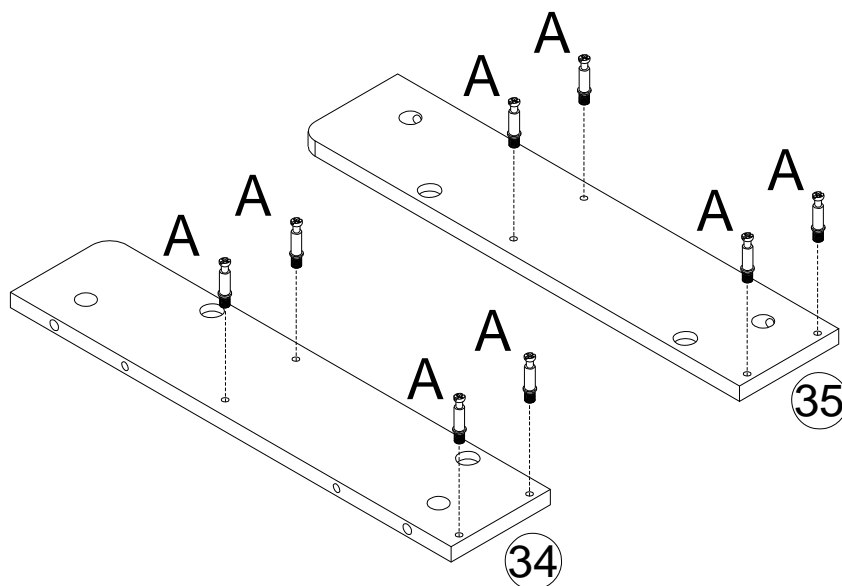

STEP 28 / ÉTAPE 28:

x2

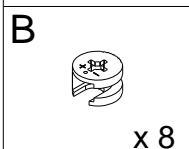
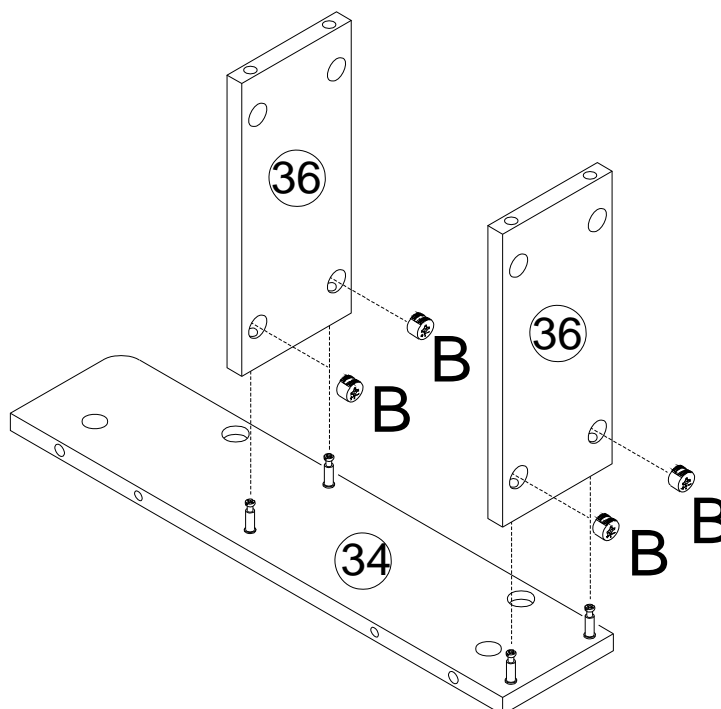

STEP 29 / ÉTAPE 29:

x2

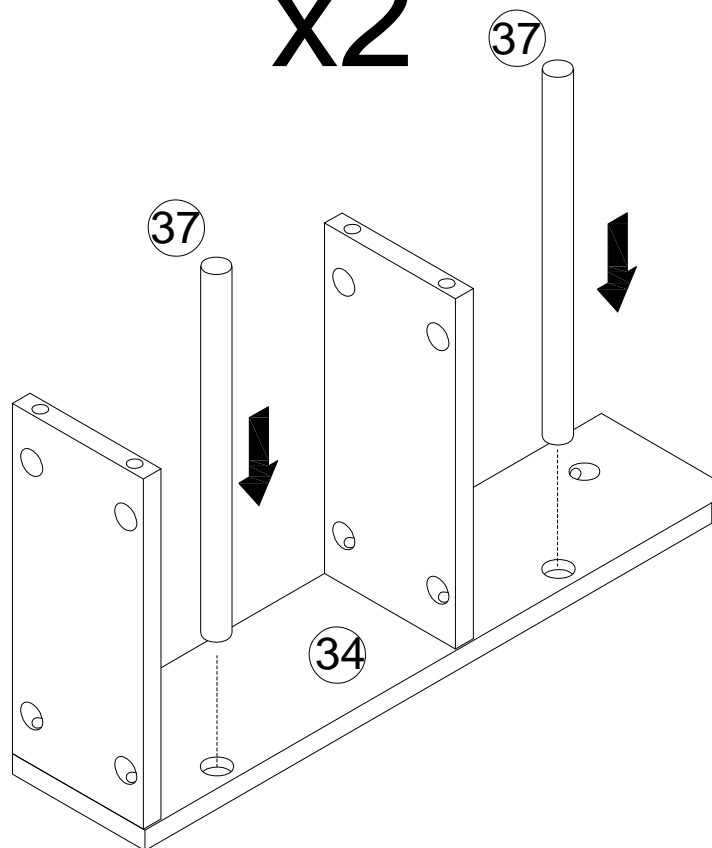

STEP 30 / ÉTAPE 30:

x2

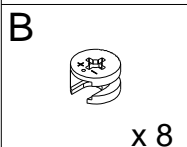
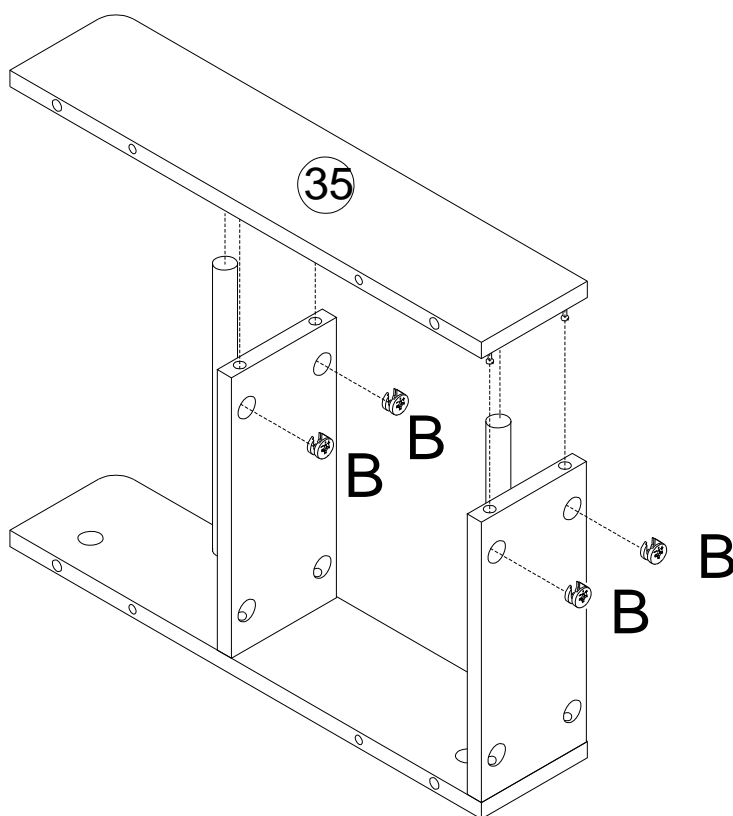

STEP 31 / ÉTAPE 31:

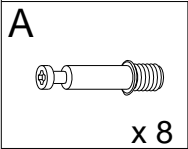
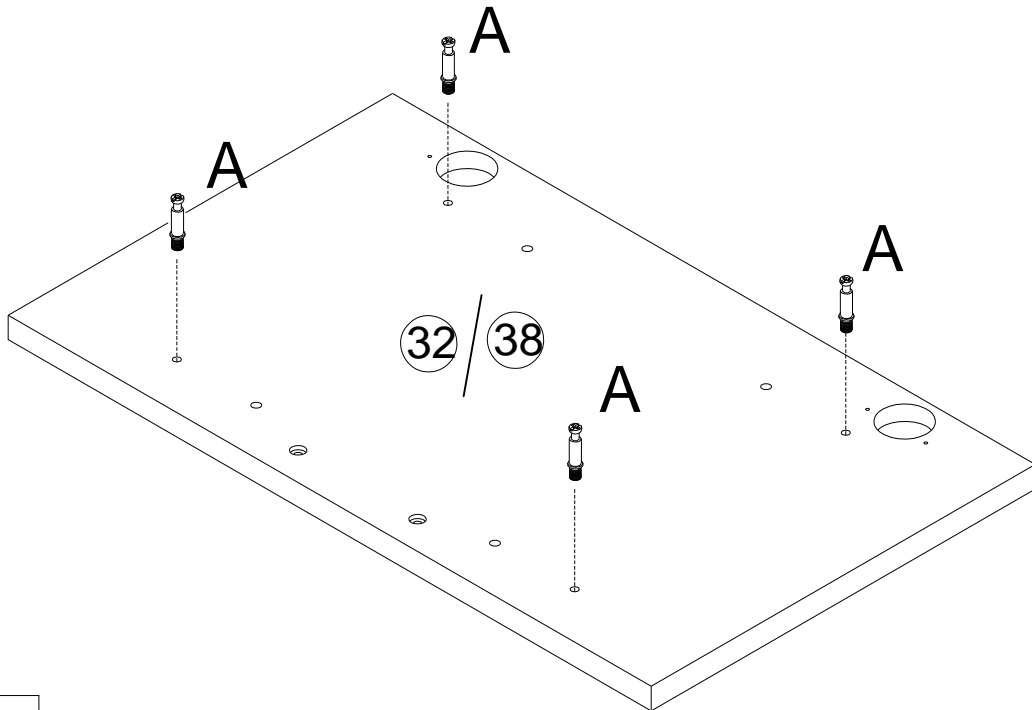

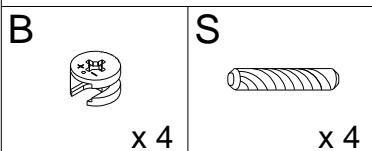
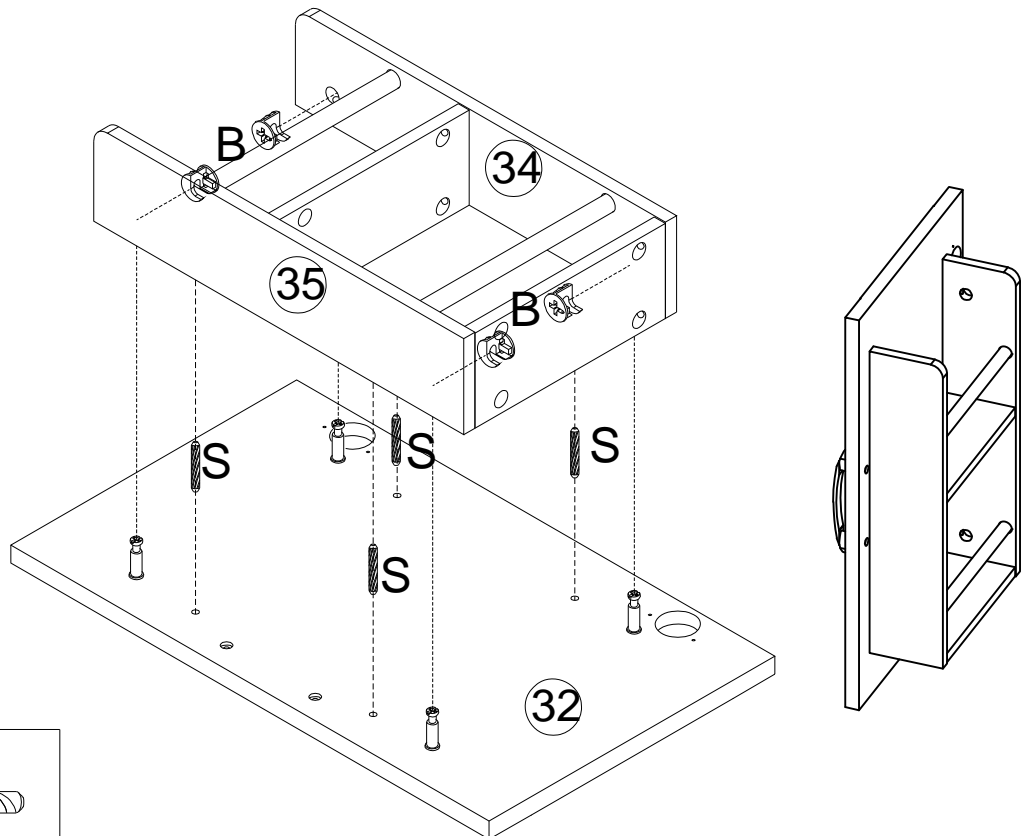

STEP 32 / ÉTAPE 32:



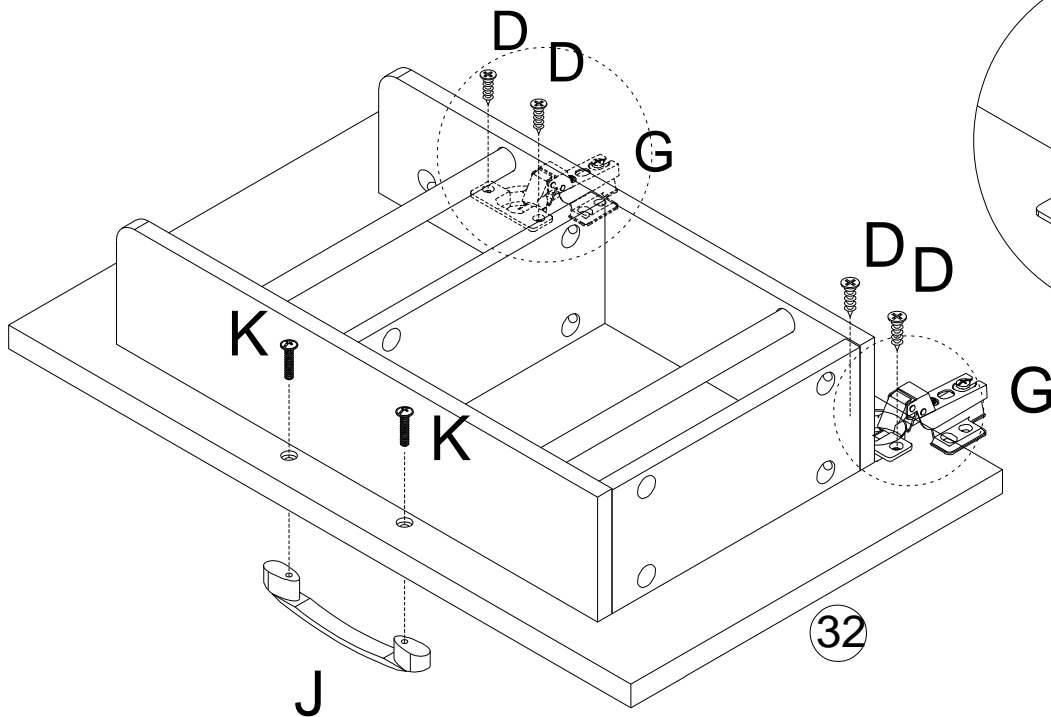

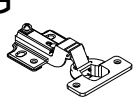
STEP 33 / ÉTAPE 33:



<p>D</p>  <p>x 4</p>	<p>G</p>  <p>x 2</p>	<p>J</p>  <p>x 1</p>	<p>K</p>  <p>x 2</p>
--	---	--	--

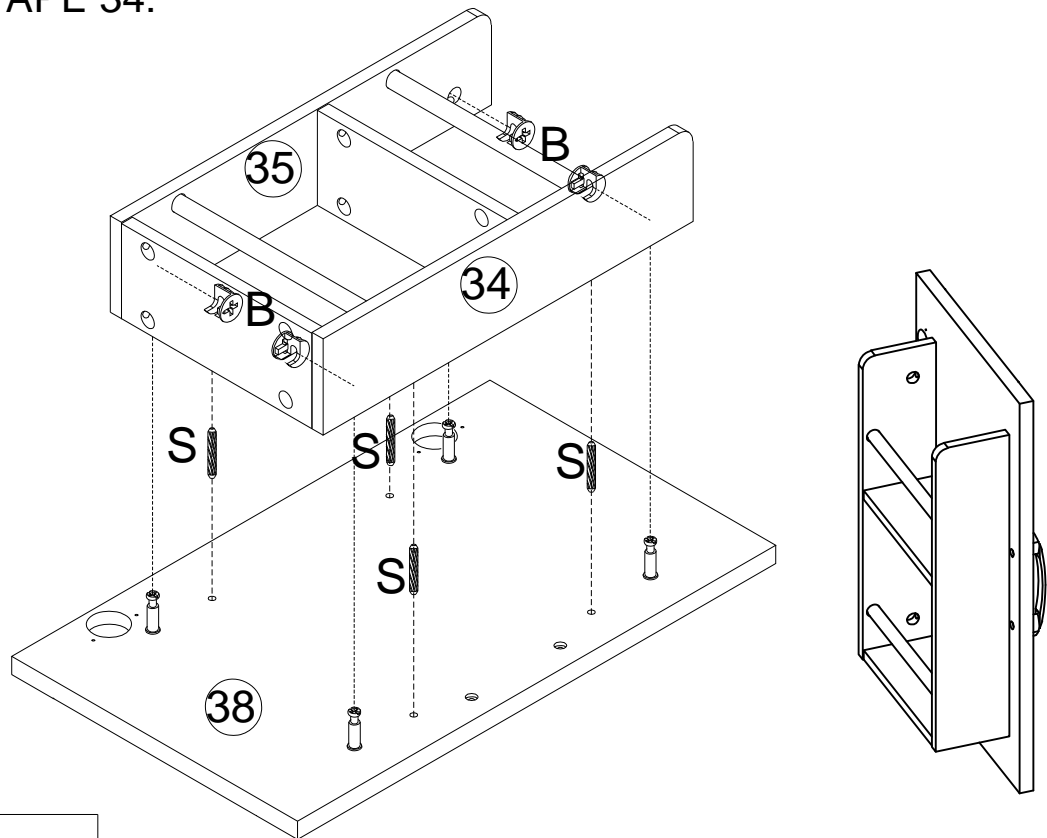

STEP 34 / ÉTAPE 34:

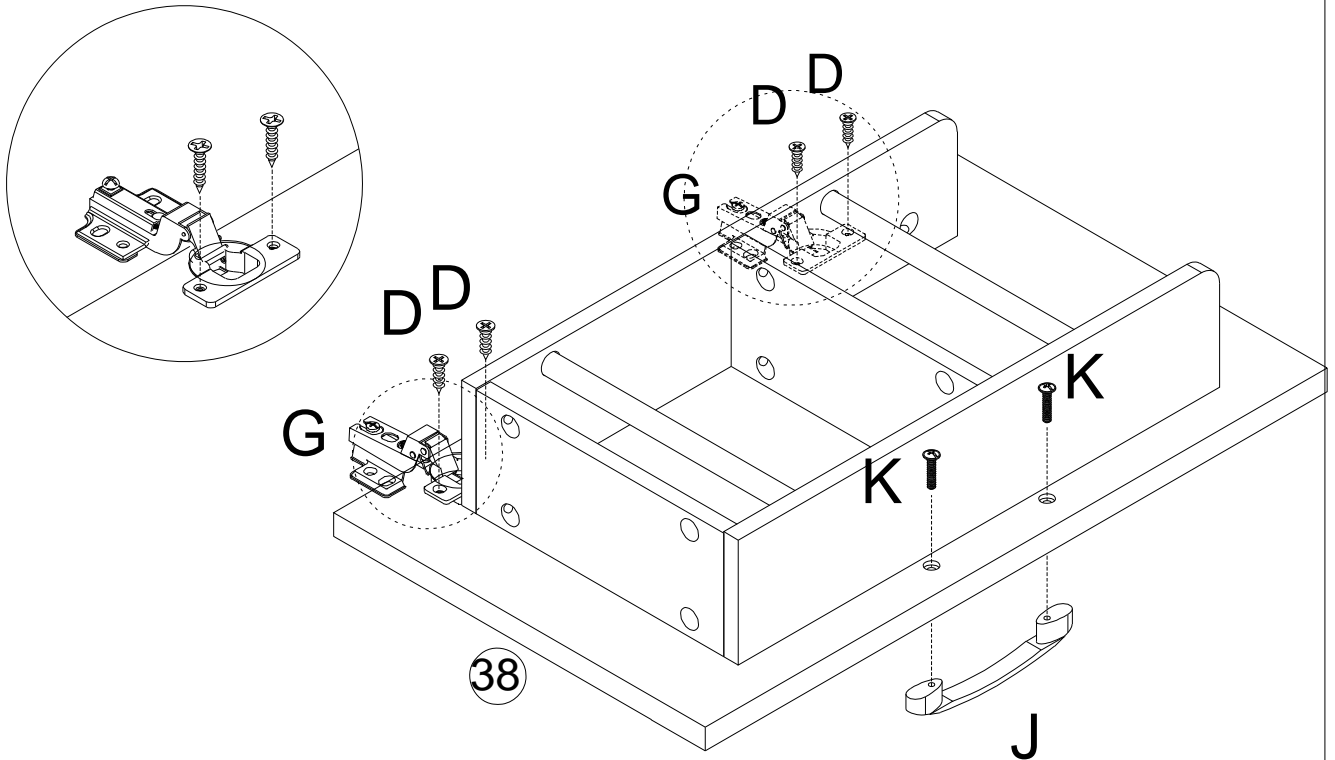

<p>B</p>  <p>x 4</p>	<p>S</p>  <p>x 4</p>
--	--

STEP 35 / ÉTAPE 35:

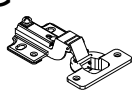

<p>D</p>  <p>x 4</p>	<p>G</p>  <p>x 2</p>	<p>J</p>  <p>x 1</p>	<p>K</p>  <p>x 2</p>
--	--	--	--

STEP 36 / ÉTAPE 36:

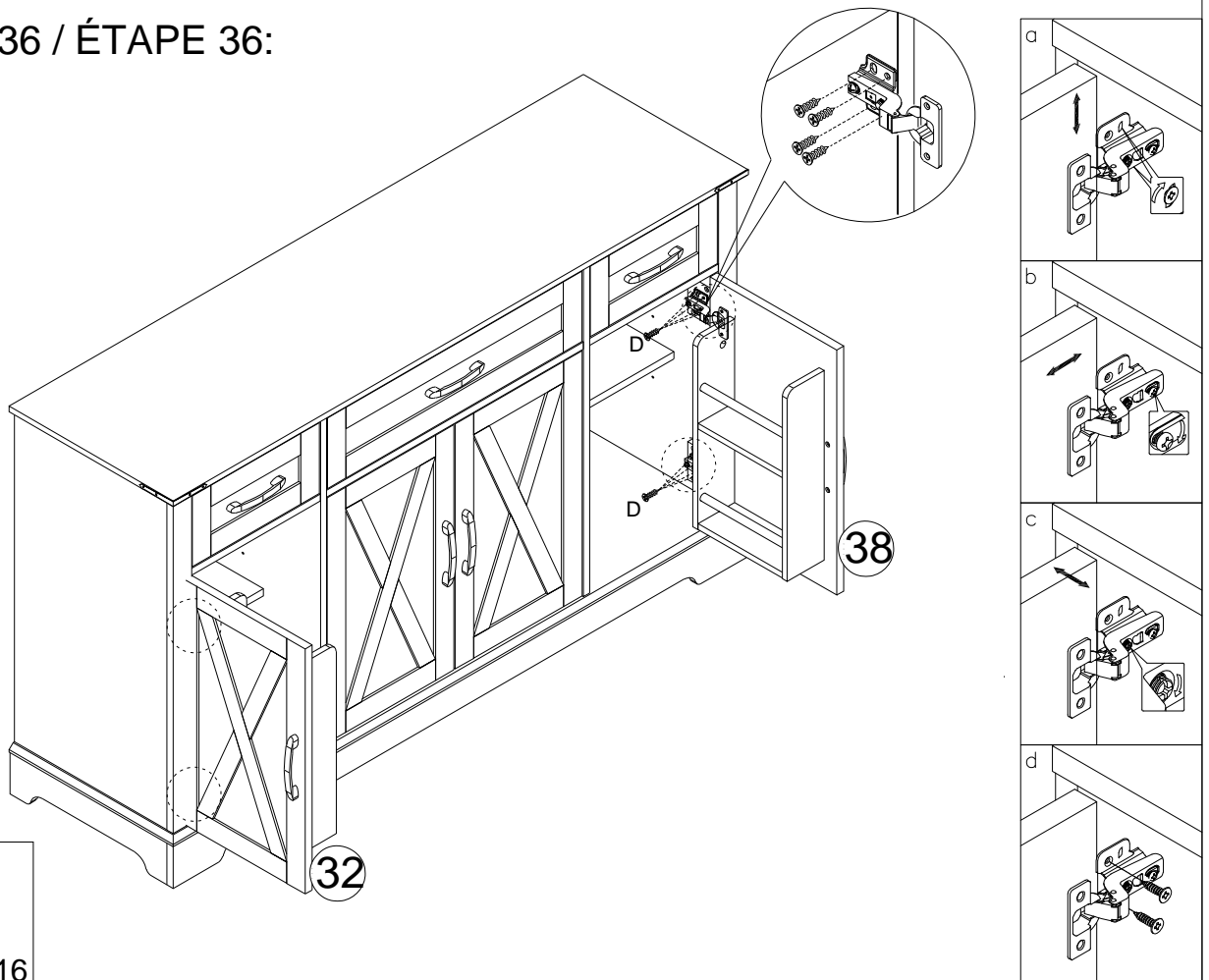

<p>D</p>  <p>x 16</p>

STEP 37 / ÉTAPE 37:

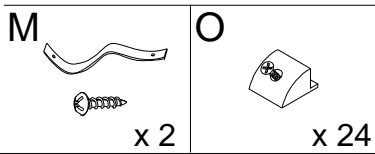
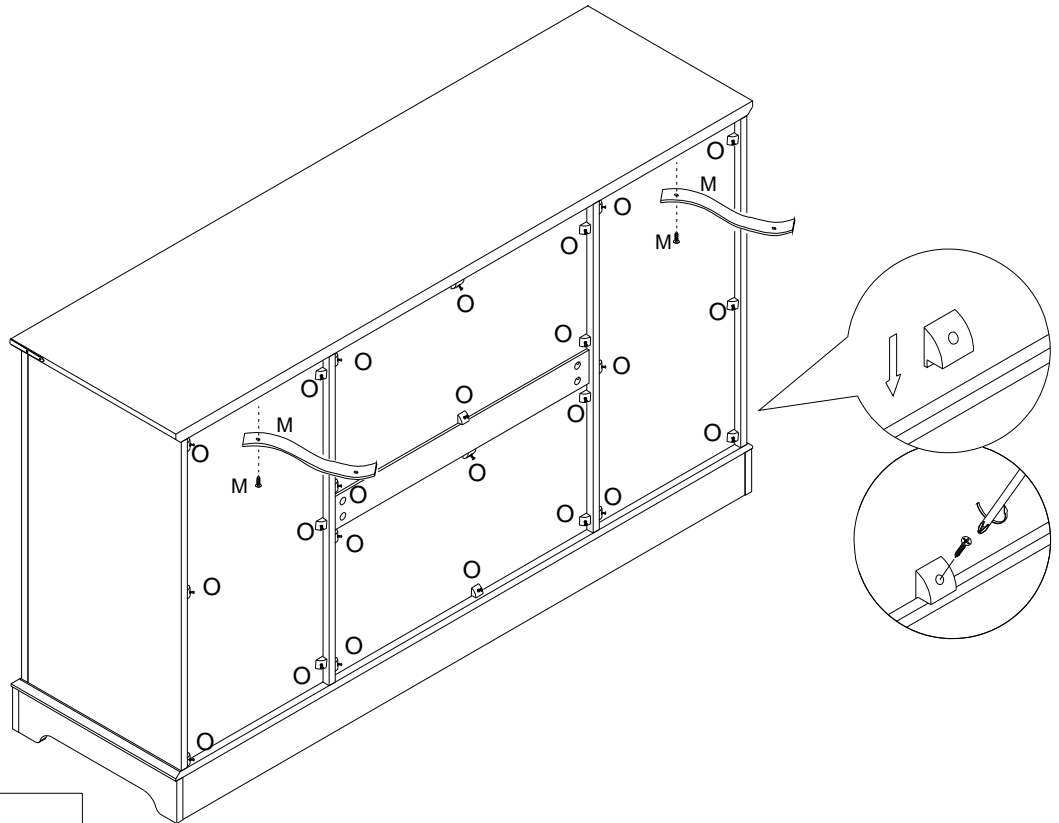

STEP 38 / ÉTAPE 38:

