

# Installation Instruction

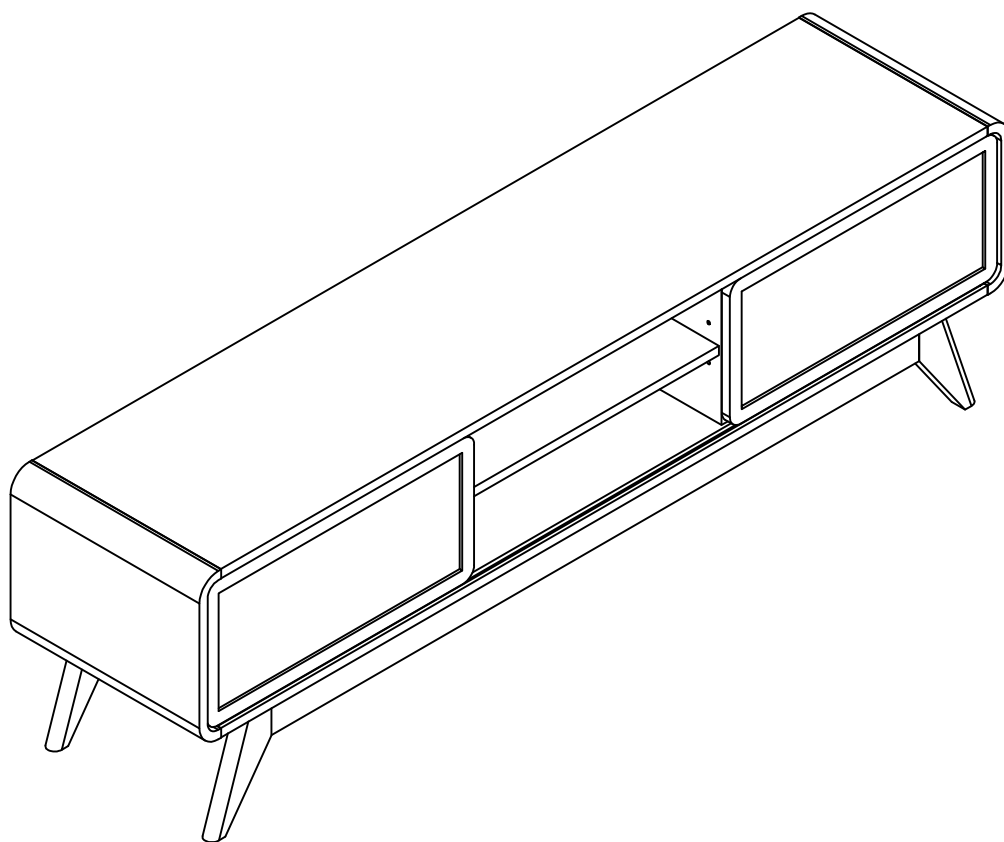

# Assembling

---

Estimated time for assembly



**45 : 00**

## What you need

- Use the packaging carton as a working surface to prevent product damage during assembly
- Phillips head screwdriver

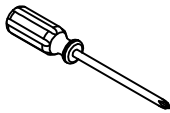

## Weight Limitation



**100** | **35**  
lbs table top    lbs per

# What' included

---

Code	Description	Qty
A	Cam Bolt M6X35MM	38
B	Cam Lock 15X10MM	38
C	Wooden Dowel M8X30MM	28
D	Screw M4X40MM	6
E	Anti-collision particle	4
F	MATS	4
G	Sliding wheel	4
H	Screw M3.5X14MM	20
I	Shelf Holder	4
J	Plastic Angle code	10
K	Anchor	2
L	Nylon Strap	2
M	Circular hole Decals	12

# The Hardwares

(A)

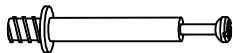

(B)



(C)



(D)

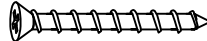

(E)



(F)



(G)

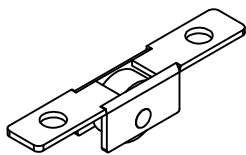

(H)



(I)



(J)

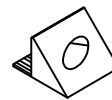

(K)



(L)

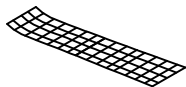

(M)

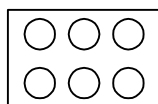

## IMPORTANT:

1. Do not tighten bolts / screws completely until all bolts / screws are lined up and inserted into holes.
2. Do not over tighten screws and bolts to avoid stripping
3. Please use hand tools to assemble this product. Do not use power tools.

# Included Accessories

---

Code	Description	Qty
1	Cabinet Top	1
2	Bottom Panel	1
3	Solid wood foot	2
4	Solid wood foot	2
5	Upper back plate	2
6	Middle fixed laminate	1
7	Left bulkhead	1
8	Lower partition board	1
9	Lateral plate	2
10	Door leaf	2
11	Left and right vertical plate	2
12	Vertical front and rear plate	2
13	Support plate	2

# The Accessoriss

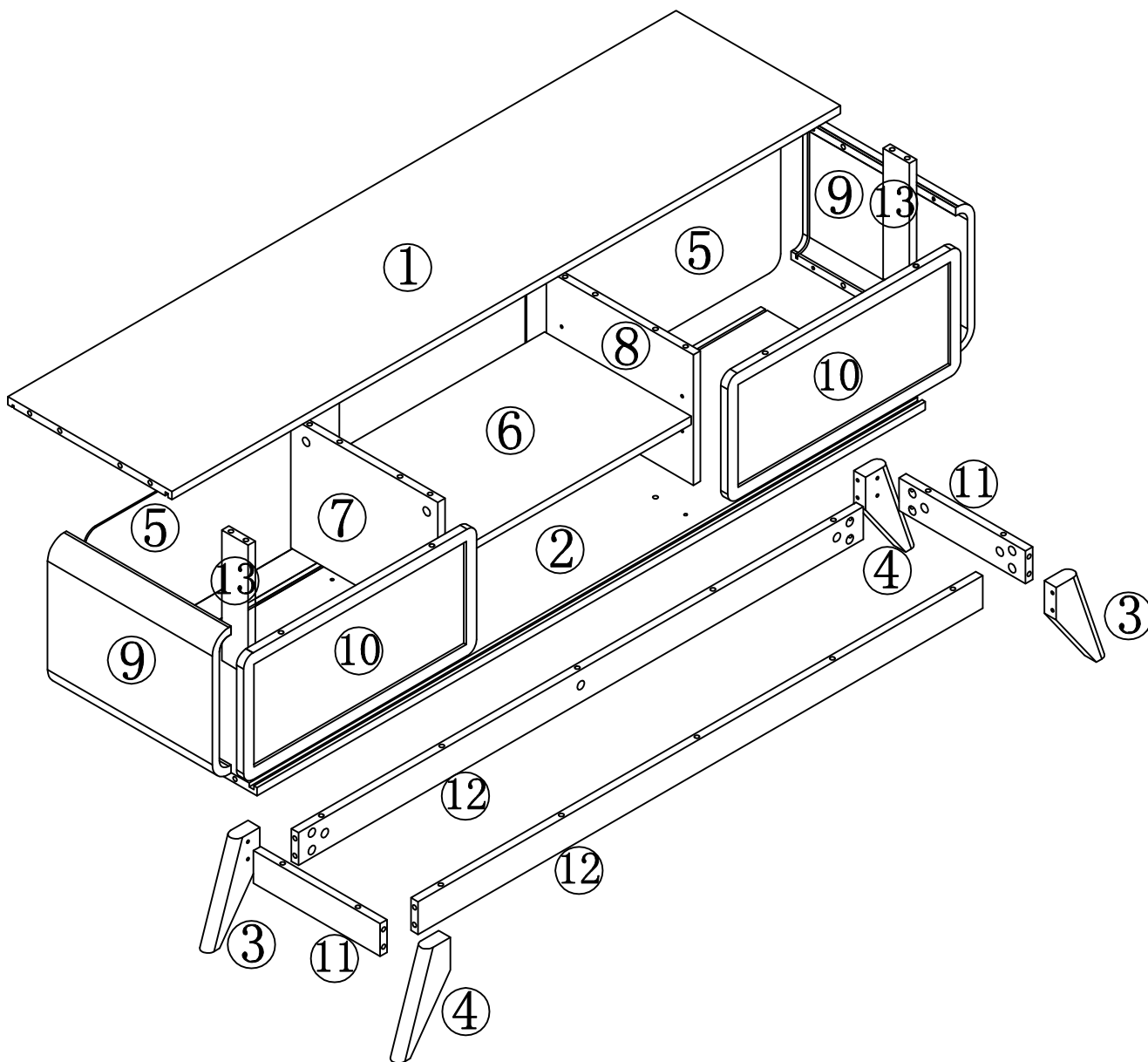

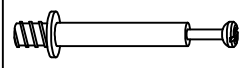
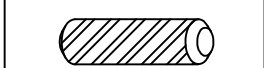

# Step 1

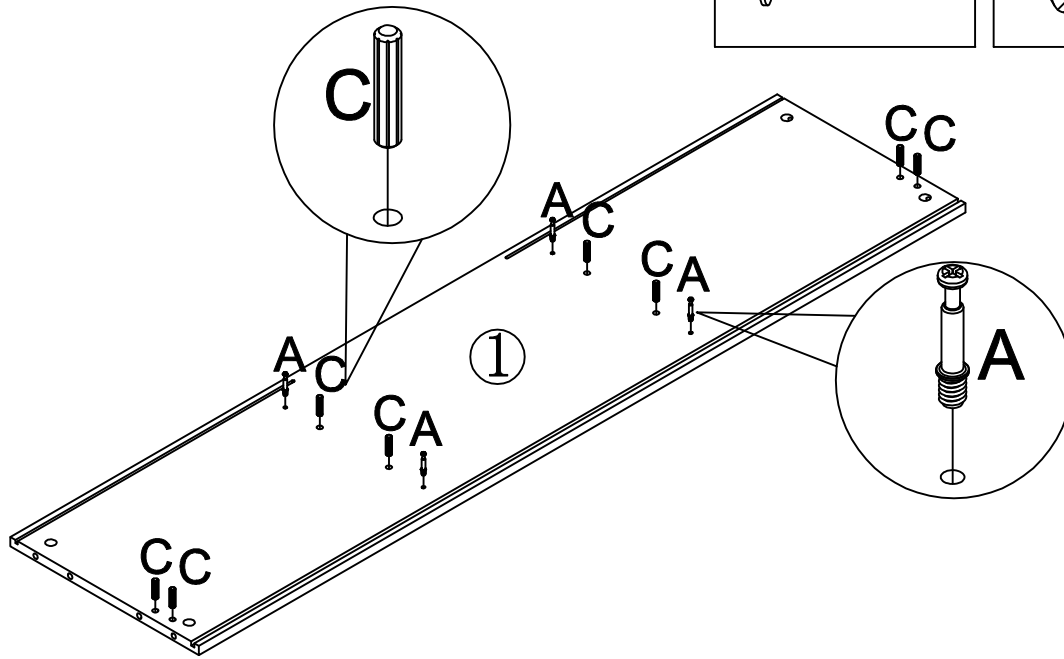
A	×4	C	×8
			

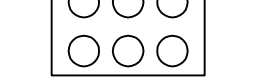

# Step 2

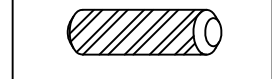
M	×4	B	×4	C	×8
					

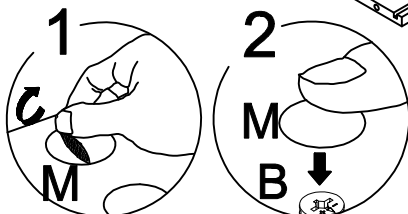
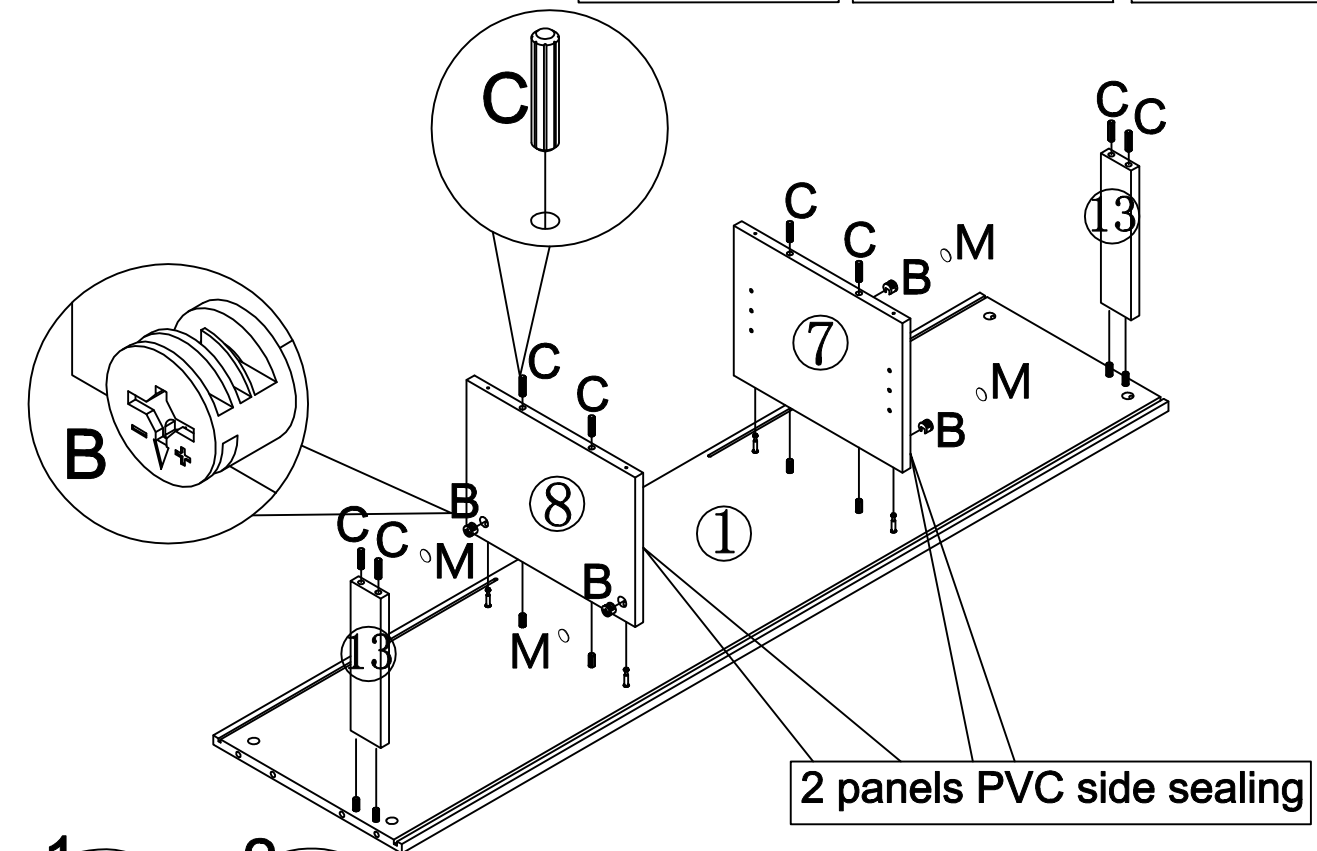

# Step 3

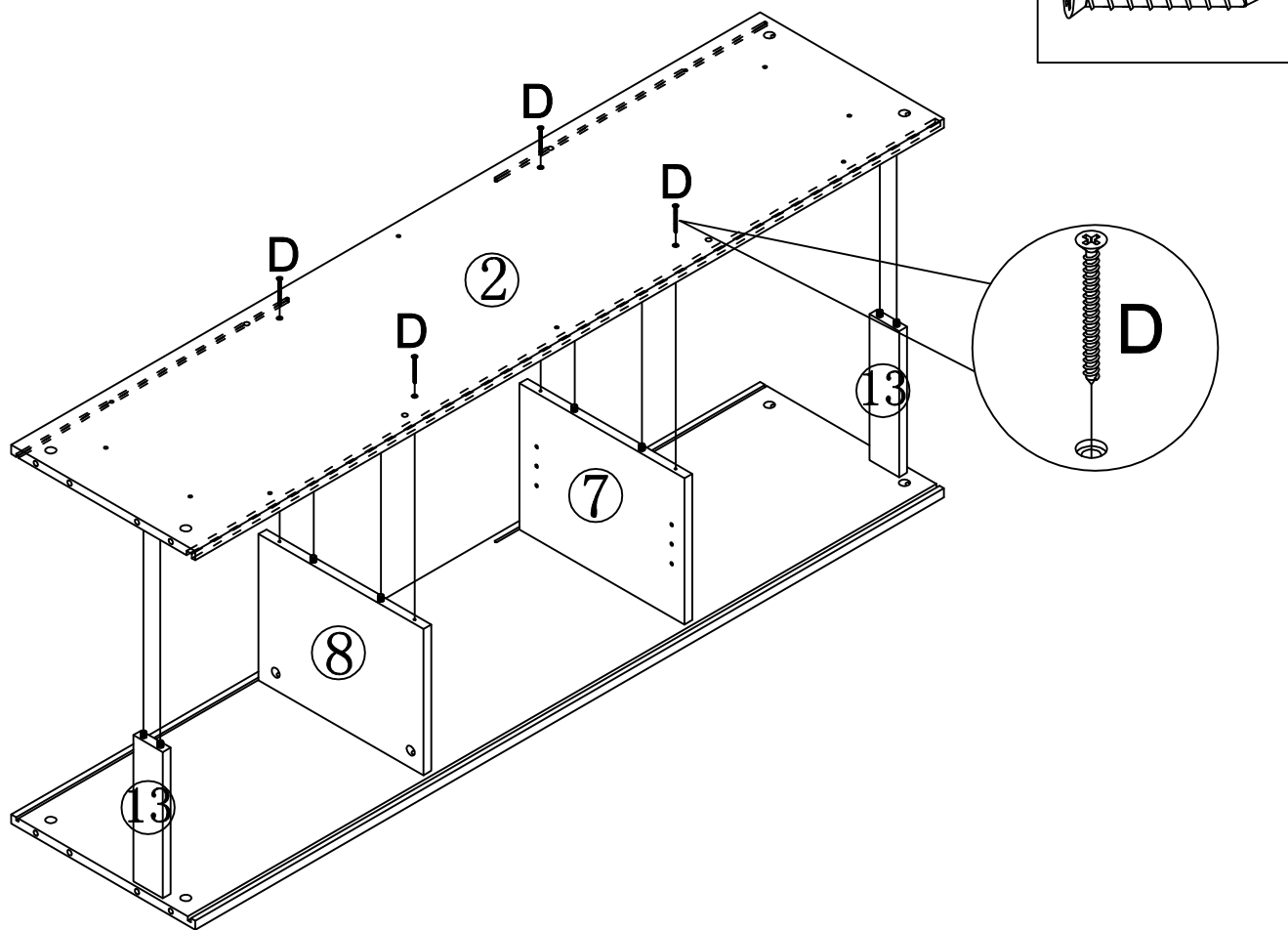

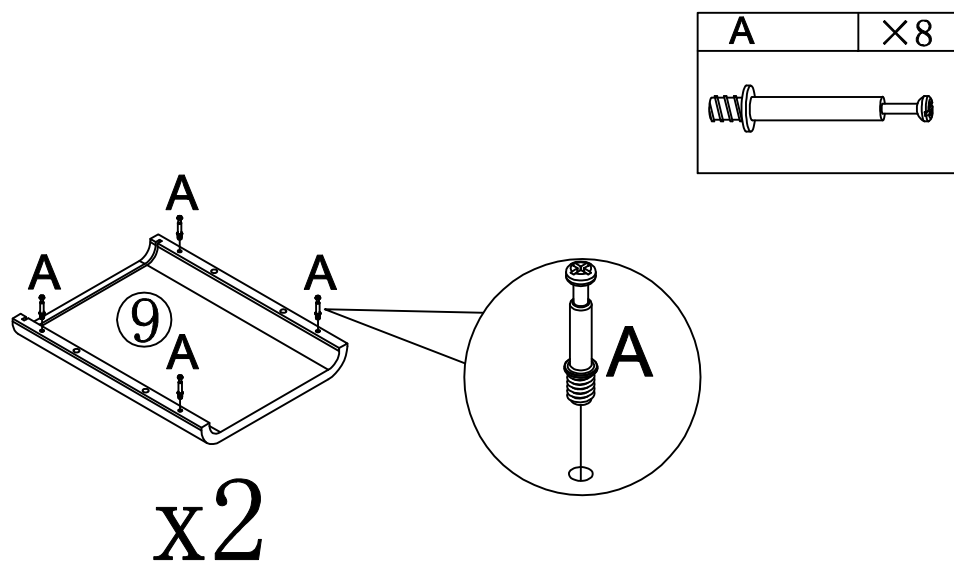

# Step 4

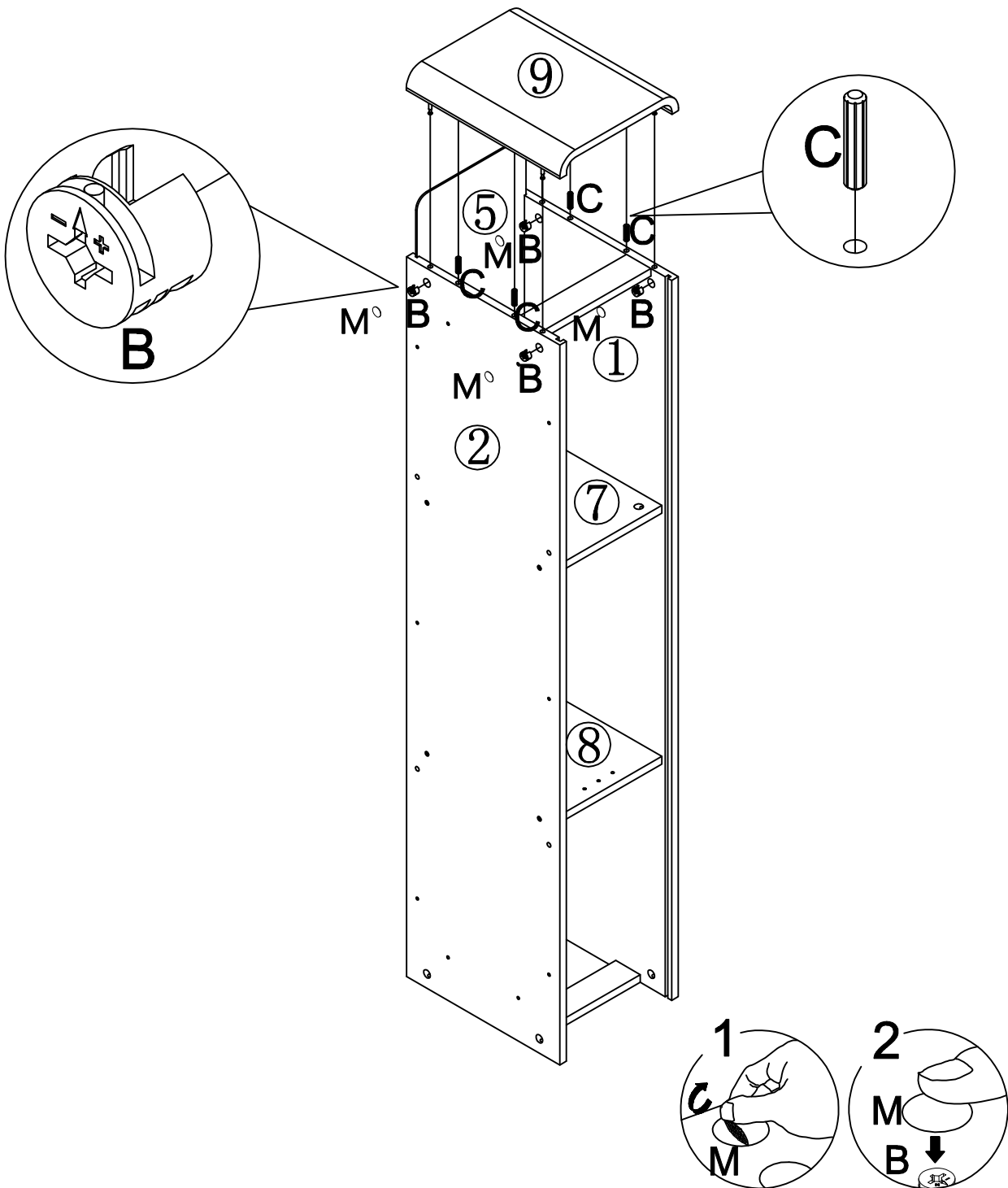
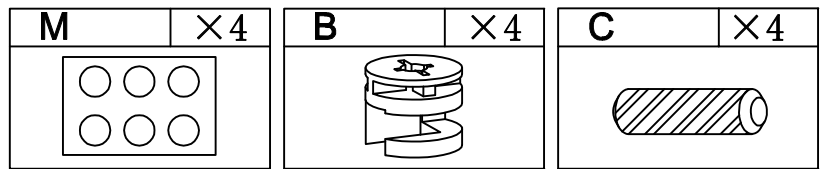

# Step 5

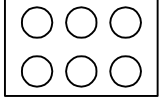

# Step 6

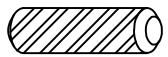
<b>M</b>	×4	<b>B</b>	×4	<b>C</b>	×4
					

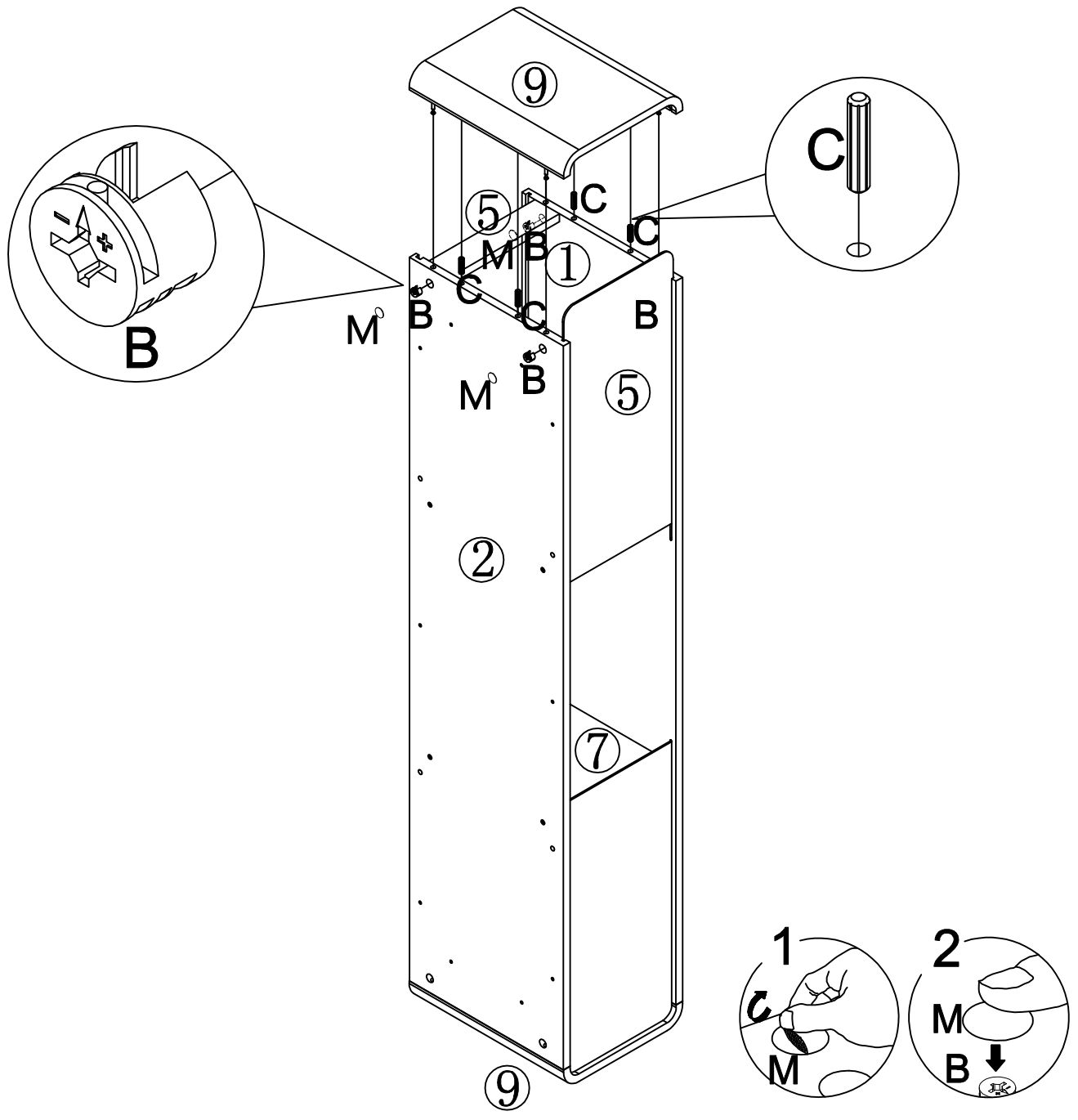

# Step 7

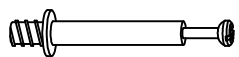
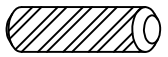
A	×10	C	×4
			

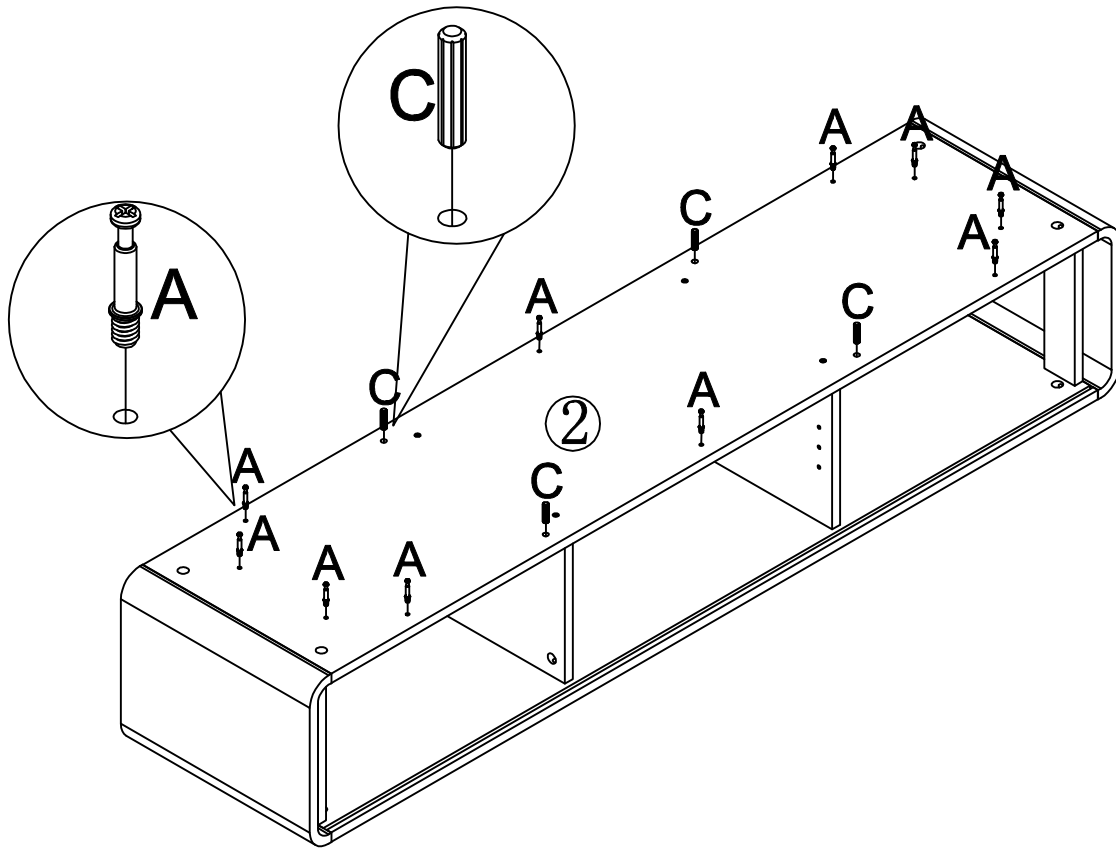

# Step 8

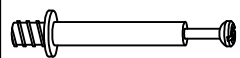
A	×16
	

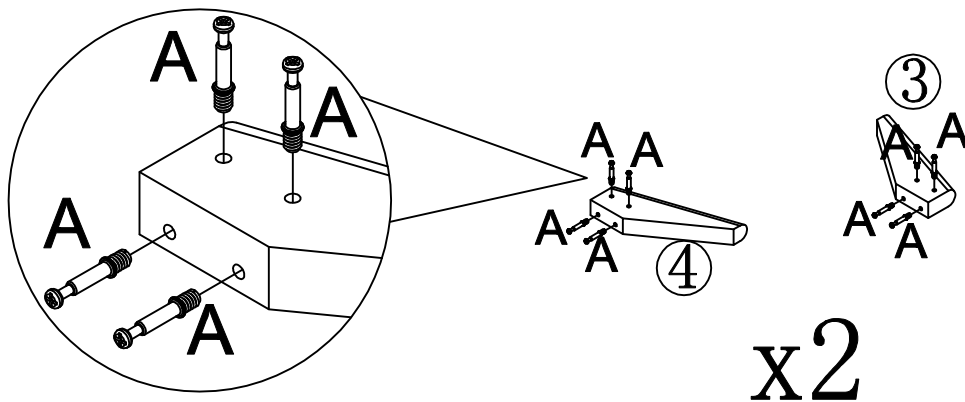

# Step 9

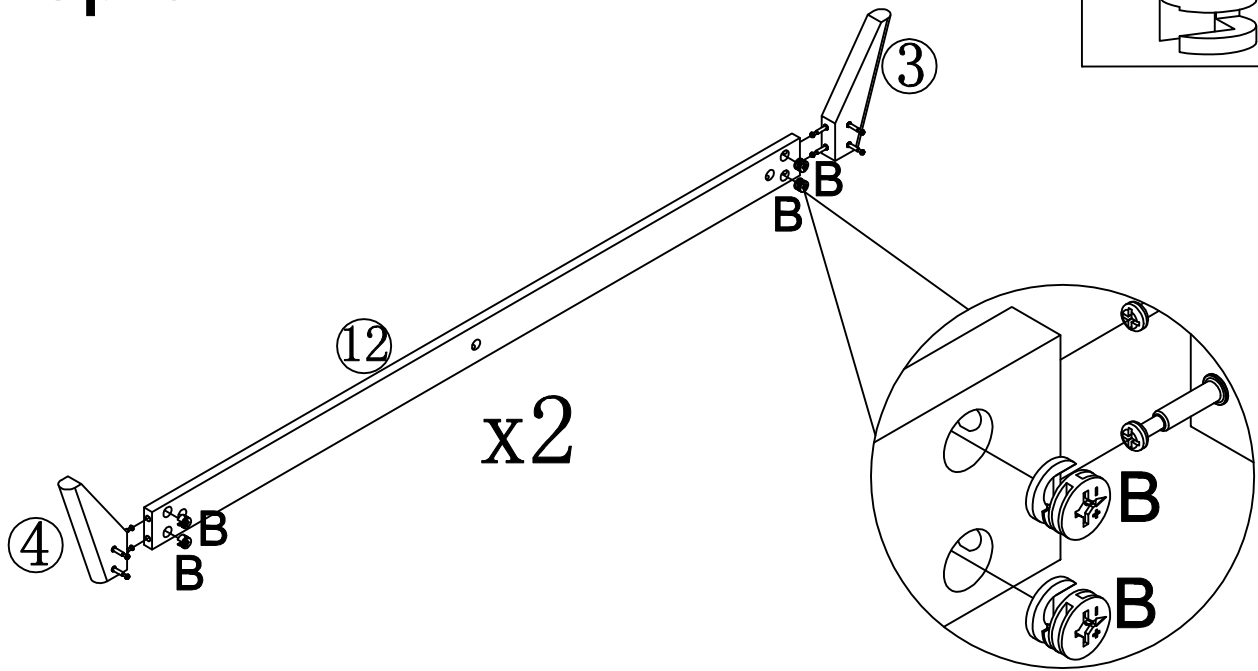
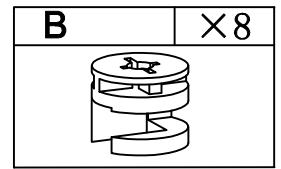

# Step 10

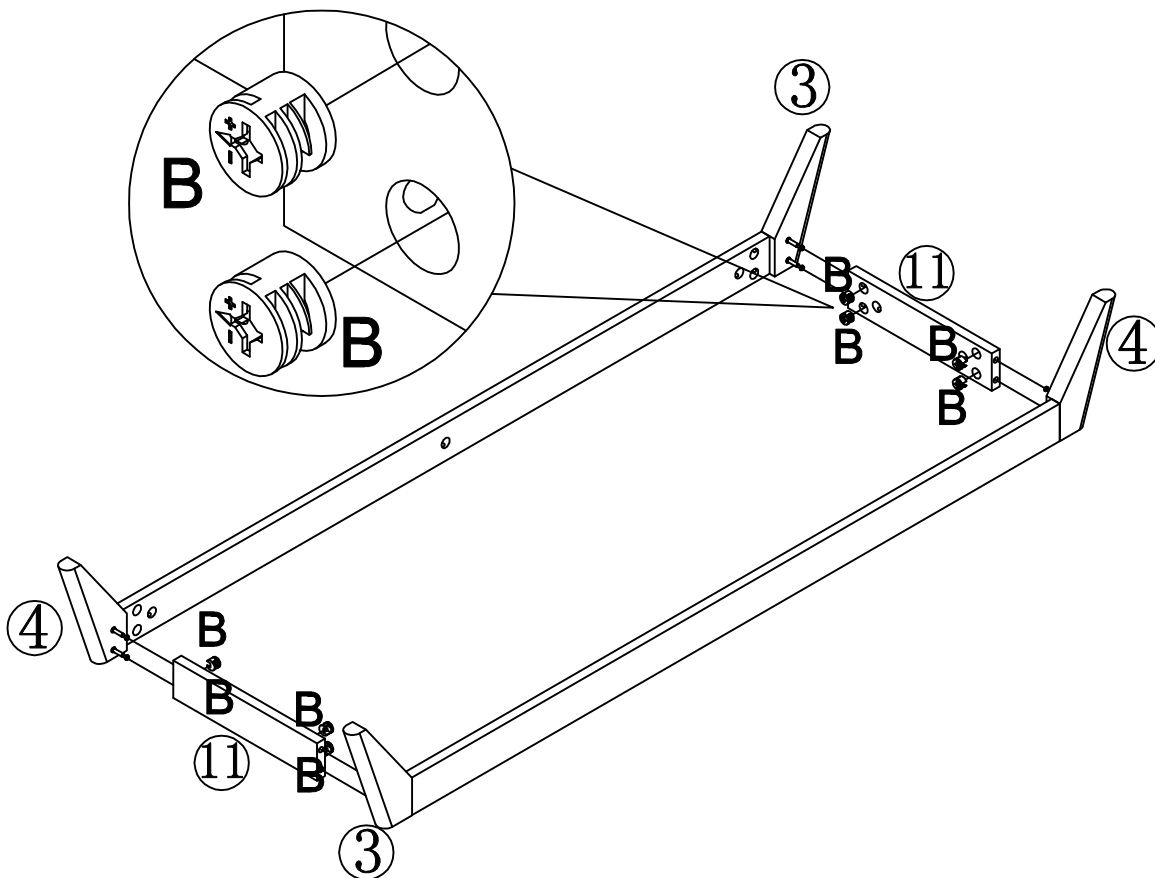
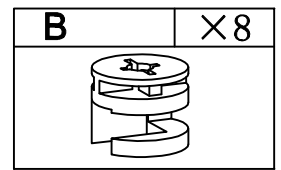

# Step 11

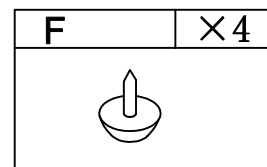
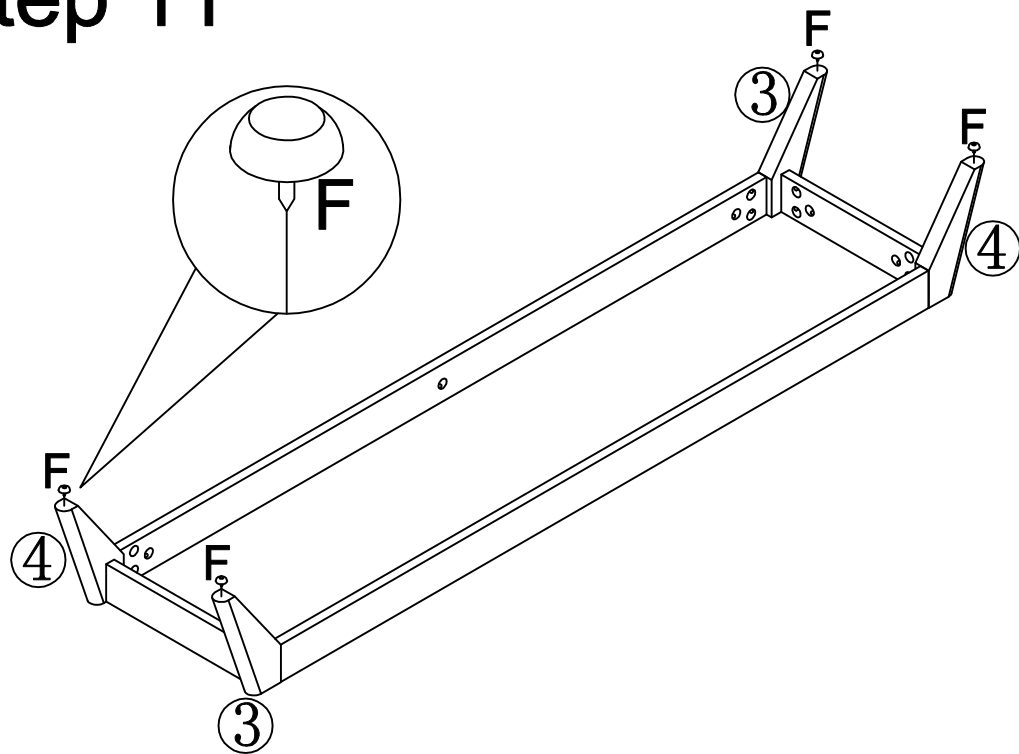

# Step 12

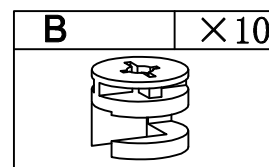
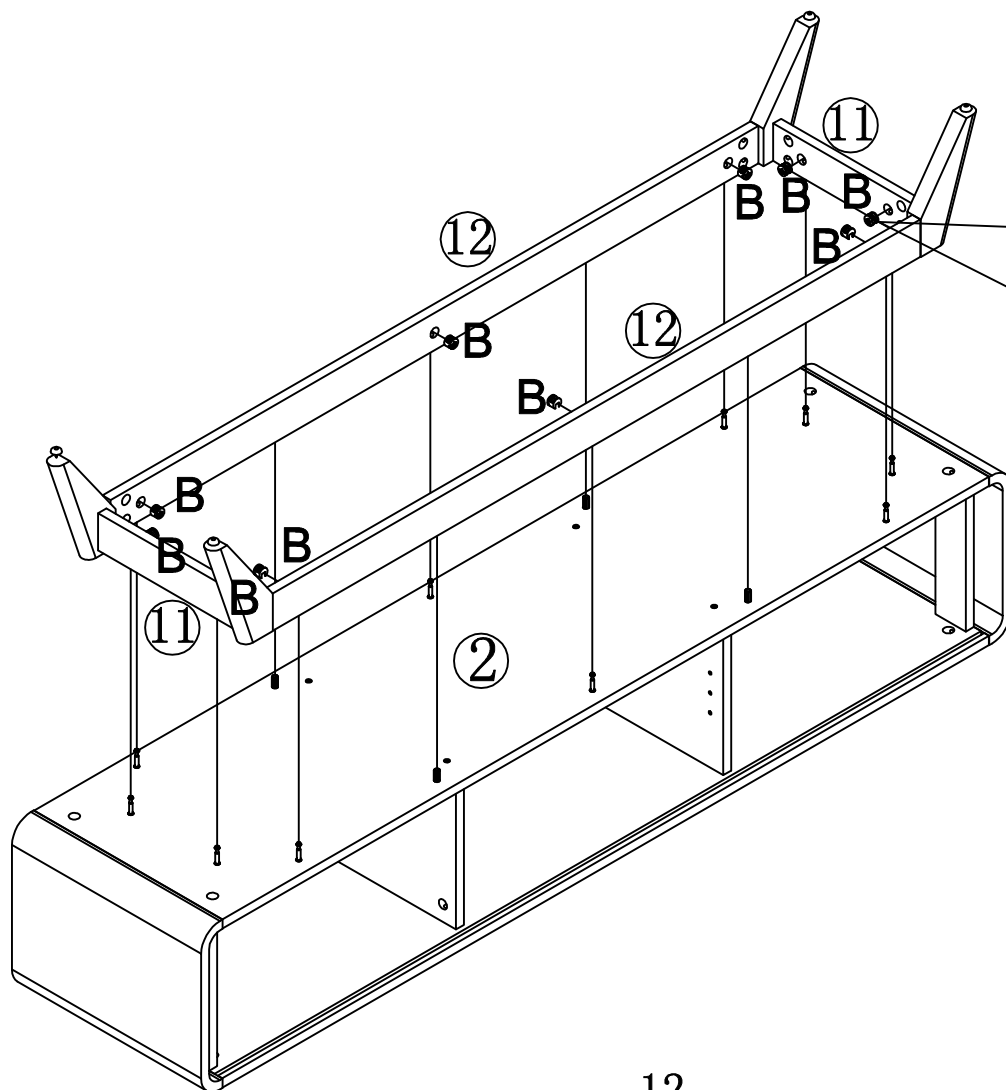

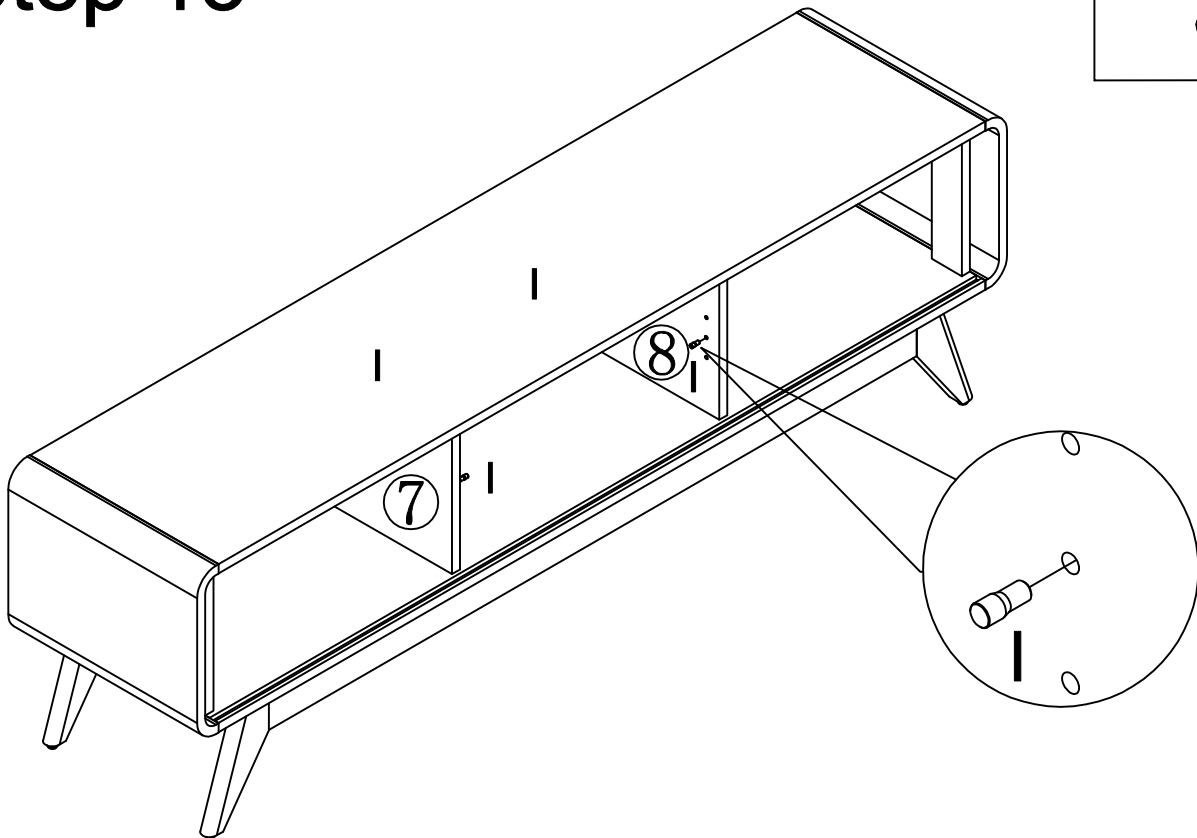
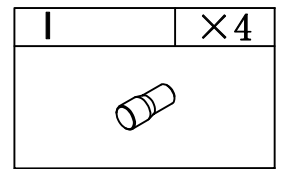

# Step 13

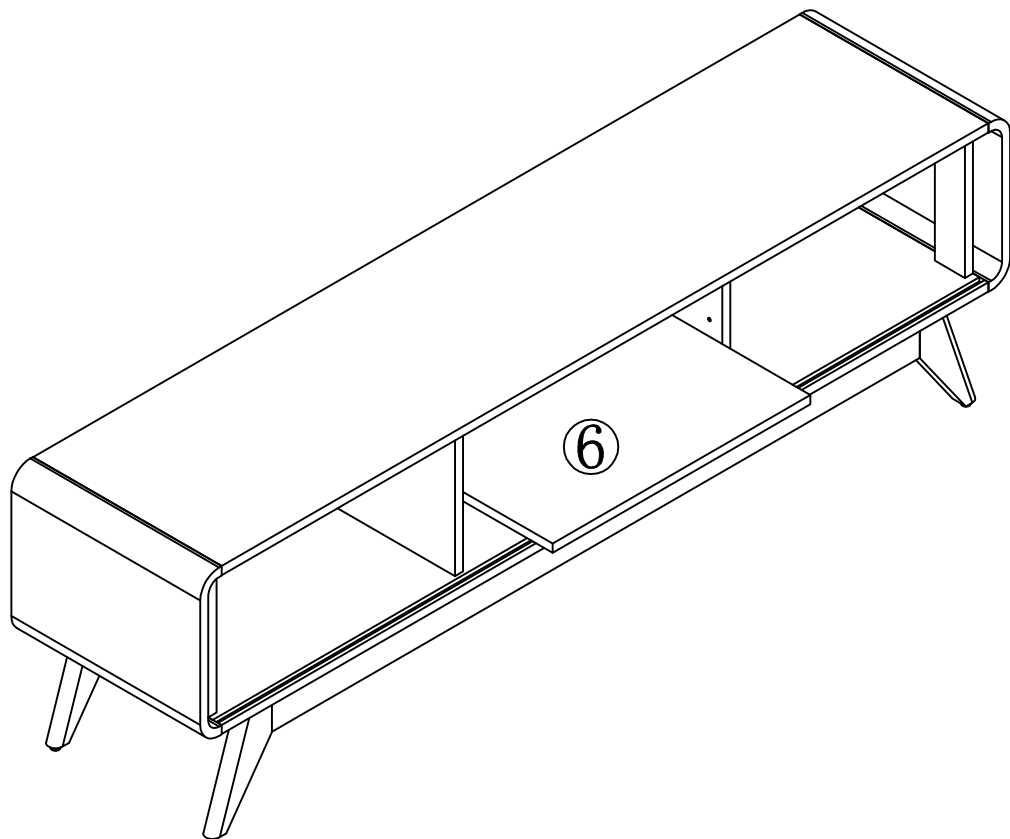

# Step 14

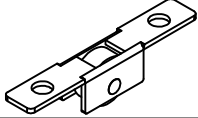

# Step 15

G	X4	H	X8
			

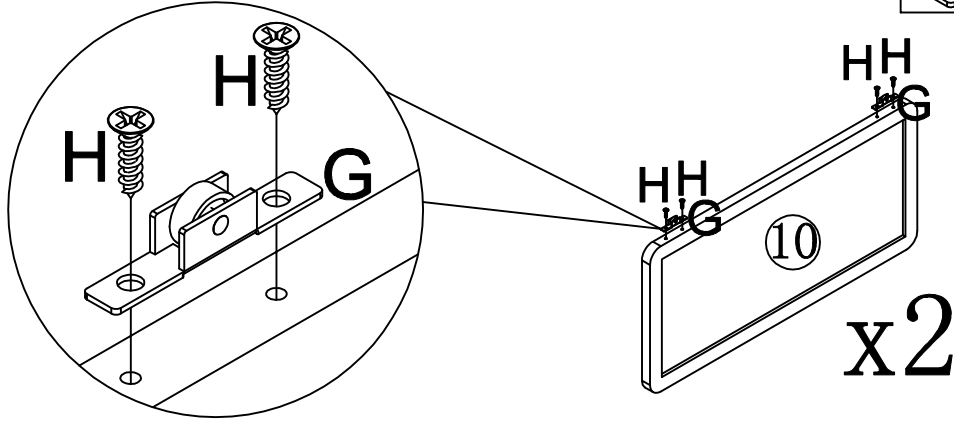

# Step 16

E	X4
	

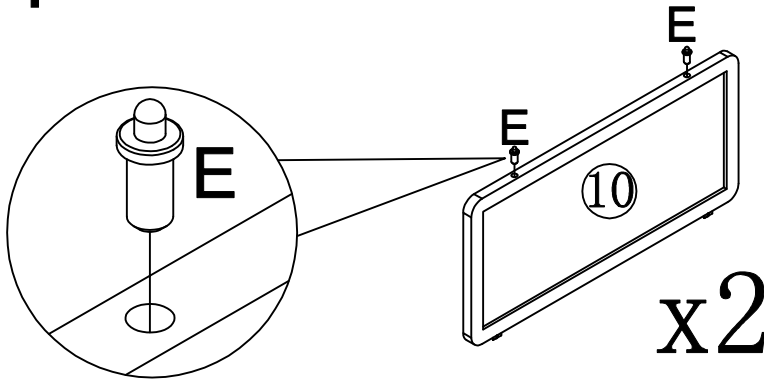

# Step 17

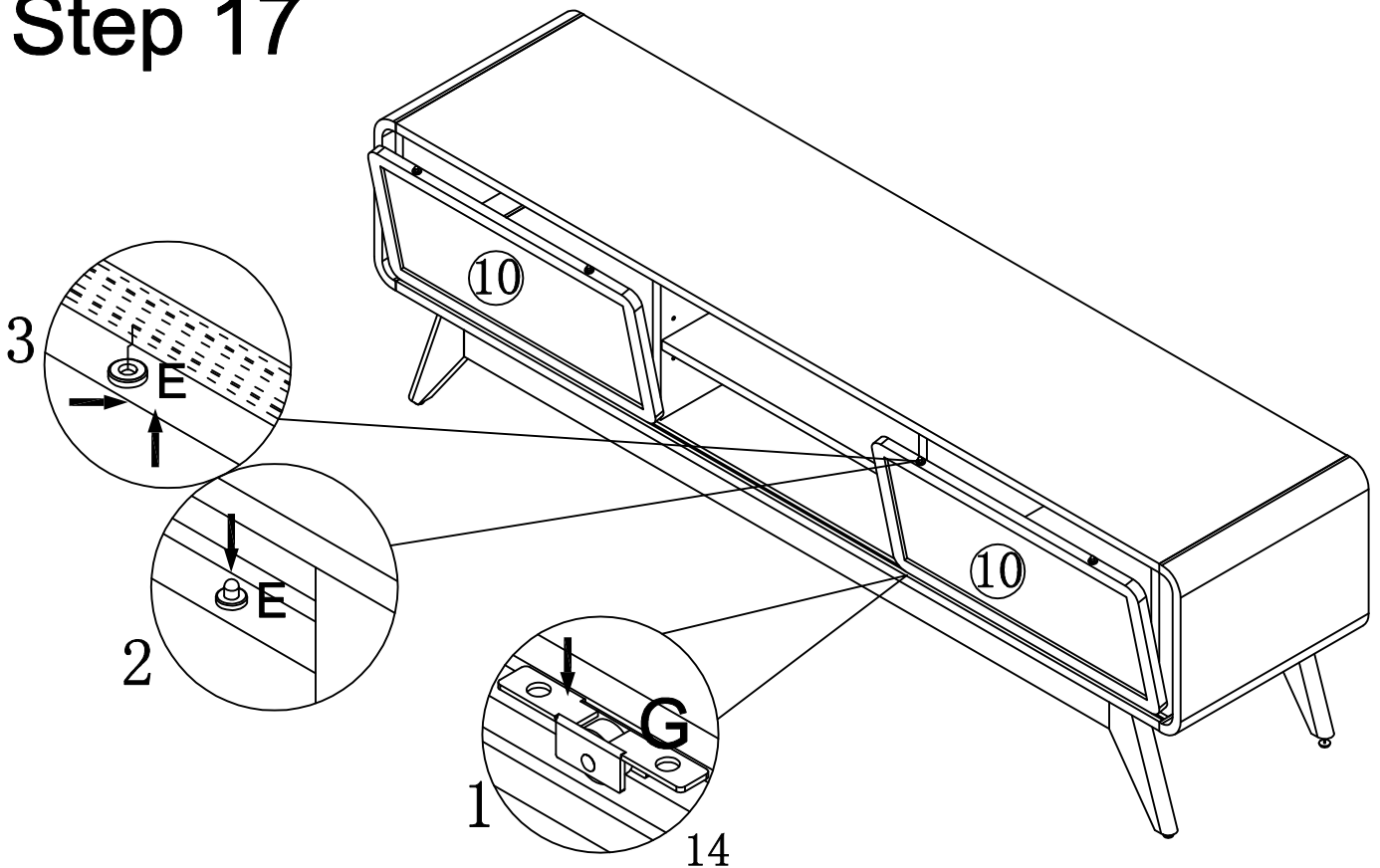

# Step 18

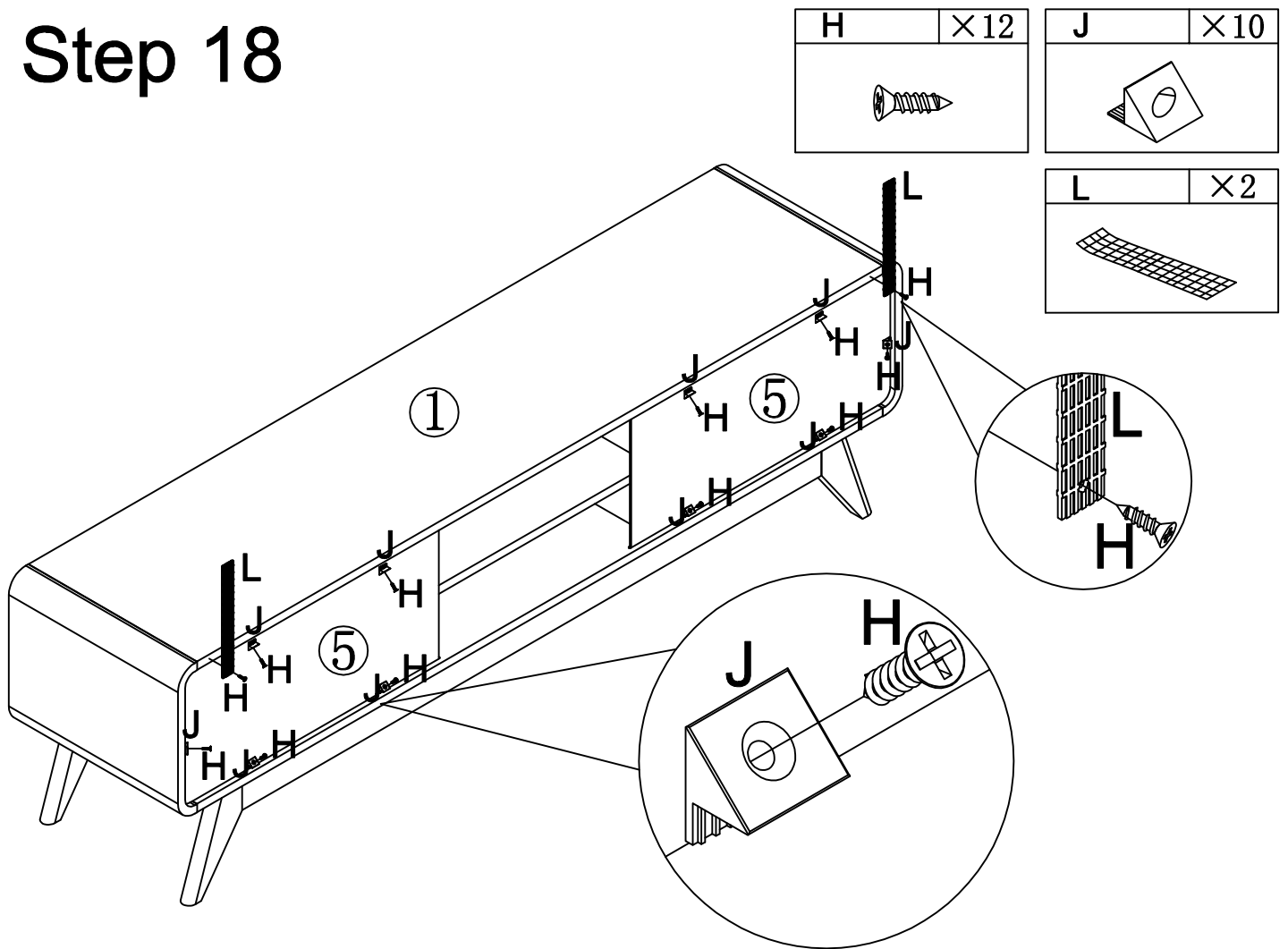

# Step 19

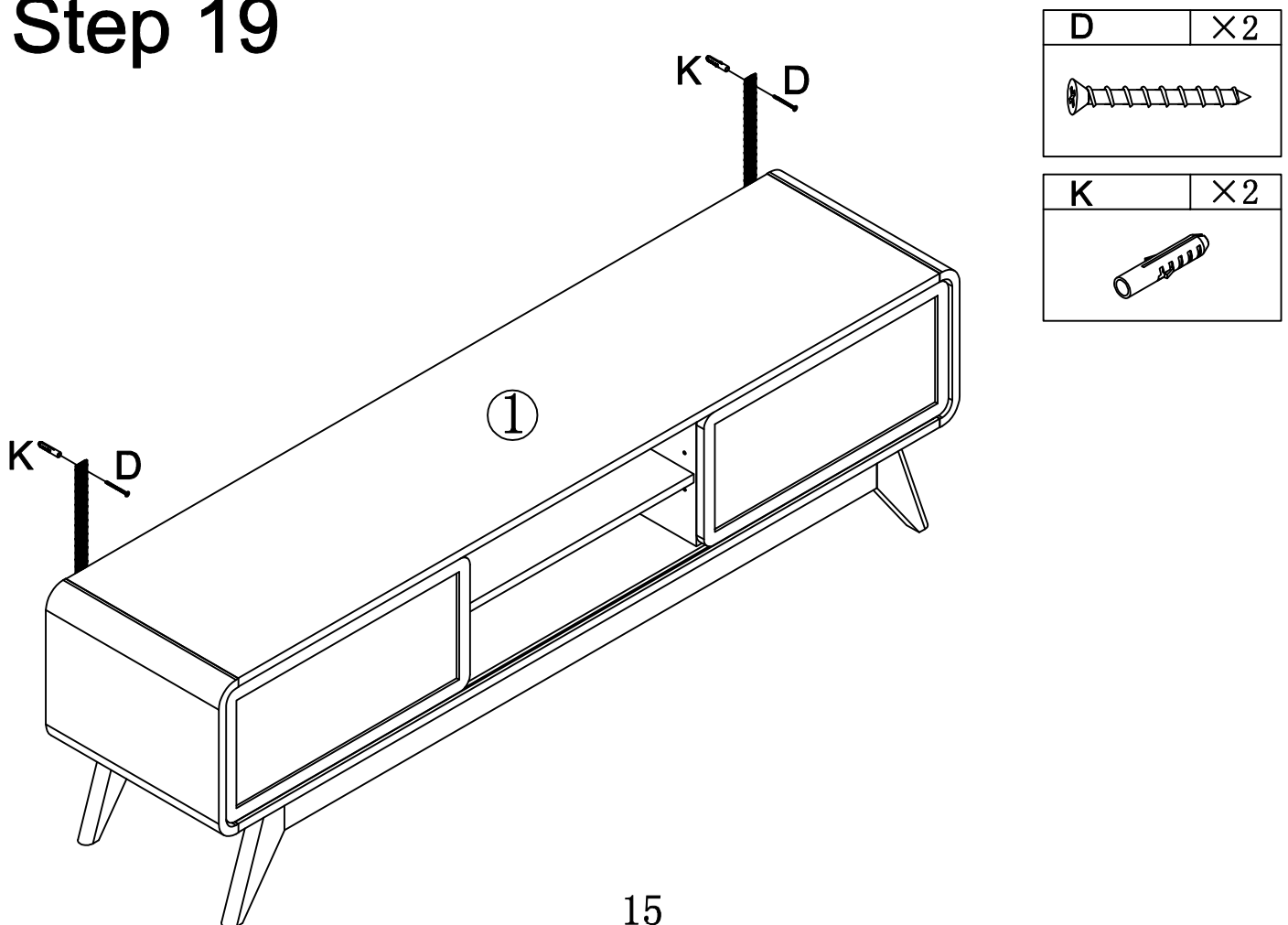

# Step 20

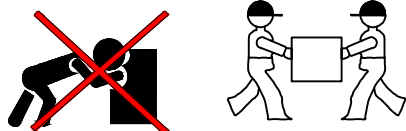
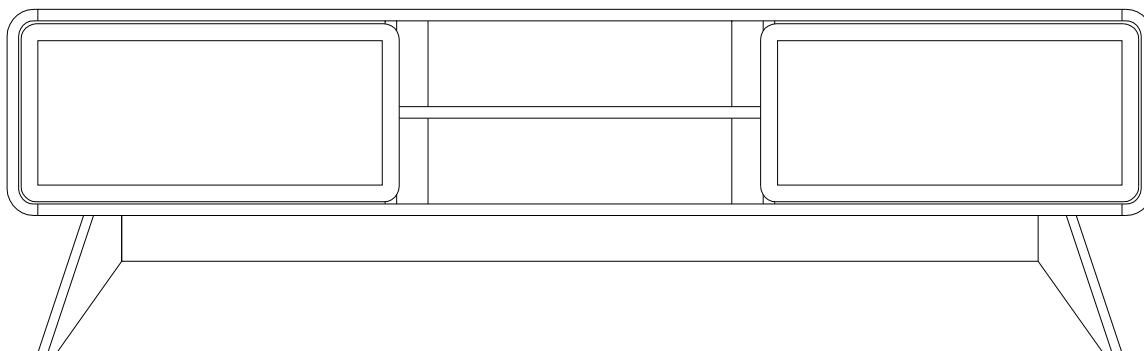
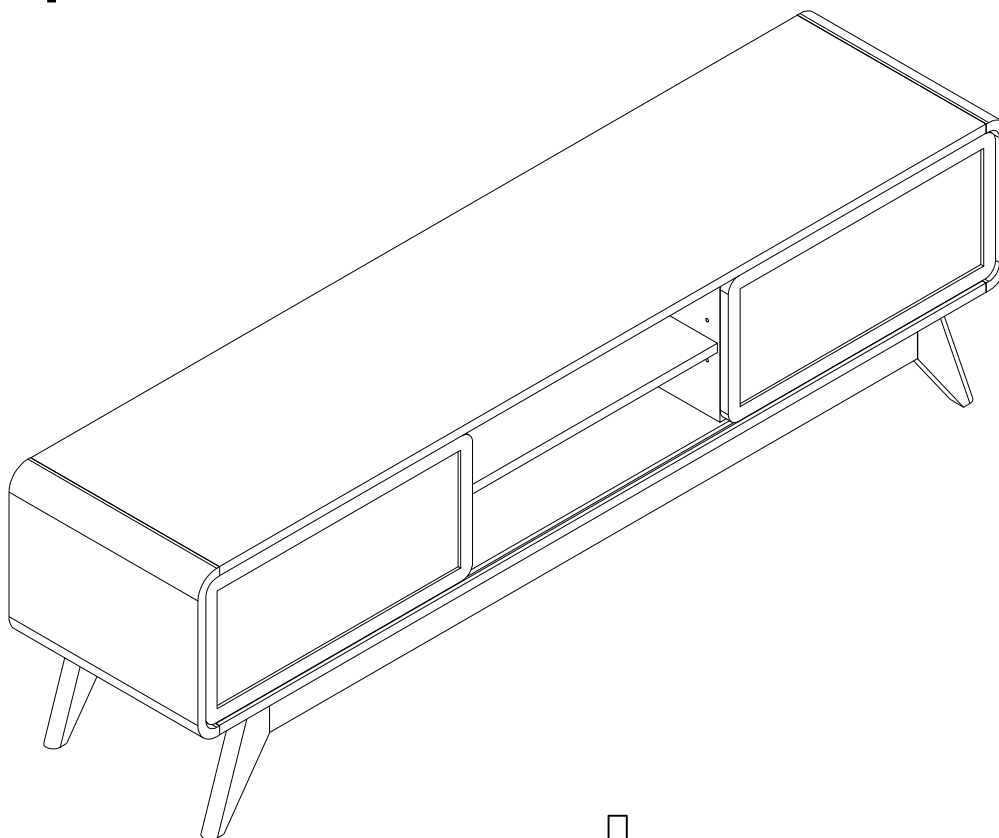

Two people work together to move the cabinet.  
Make sure you lift it off the ground.  
Don't push and pull.