

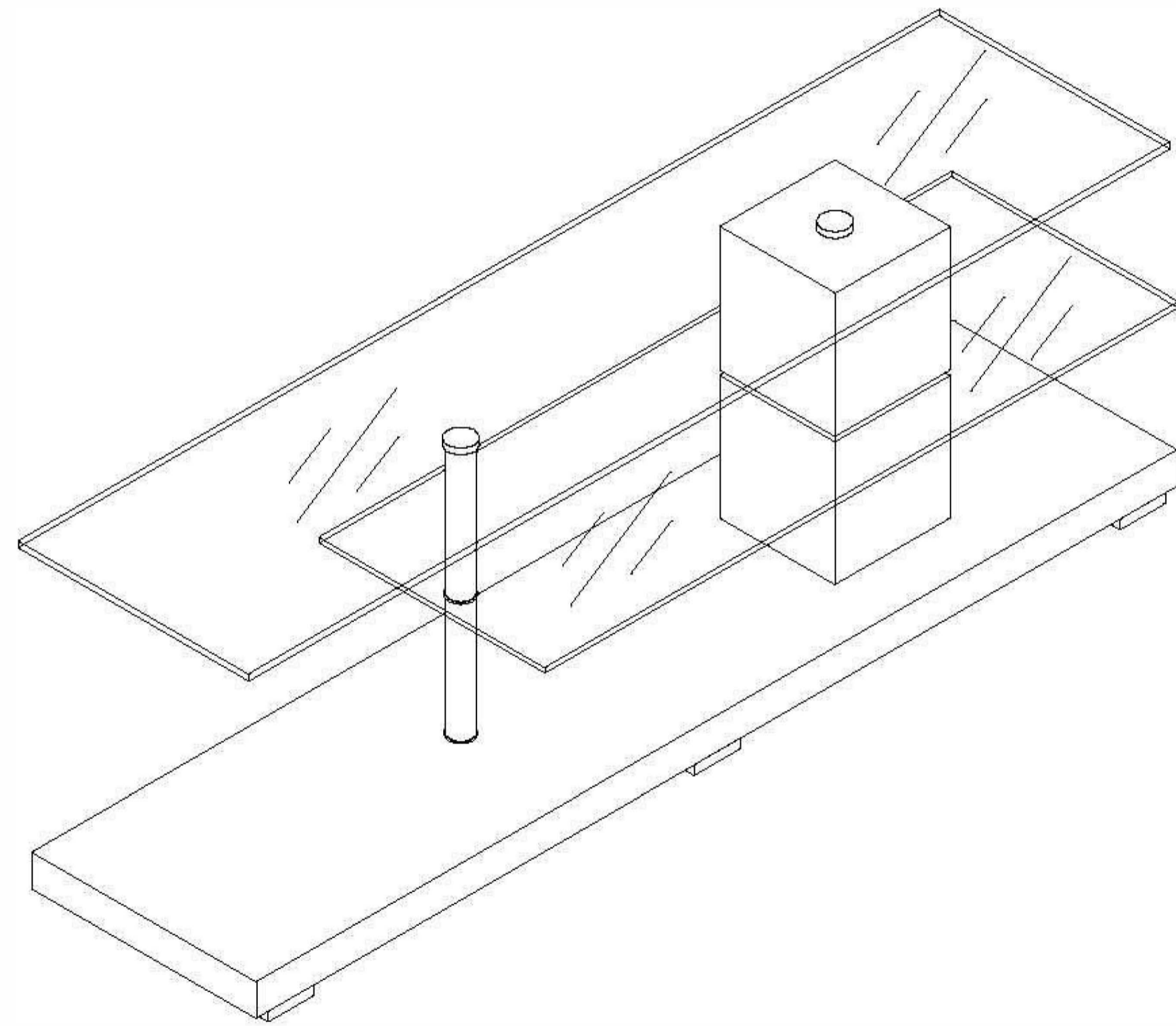

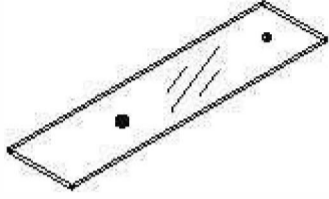

## Assembly Instructions

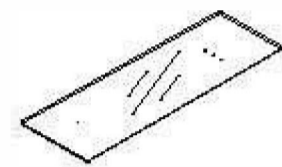

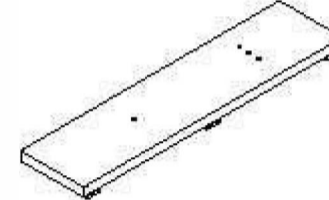

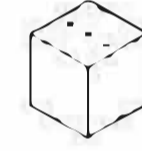





**Do not tighten screws until completely assembled.**

## PARTS IDENTIFICATION

NO	Part	Sketch	Quantity
1#		Glass top	1pc
2#		Shelf glass	1pc
3#		Bottom panel	1pc
4#		Top pole	1pc
5#		Bottom pole	1pc
6#		Shelf	2pcs

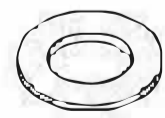
## HARDWARE LIST

NO	Shape	Specification	Quantity	NO	Shape	Specification	Quantity
A		Ø47x4.0	3pcs	F		Ø8x30	2pcs
B		M8x455	2pcs	G		M6x30	2pcs
C		M8x6.5	2pcs	H		Ø14xØ6x1.0	2pcs
D		Ø18xØ8x1.0	2pcs	I		4x4	1pc
E		8#	1pc				

STEP 1.

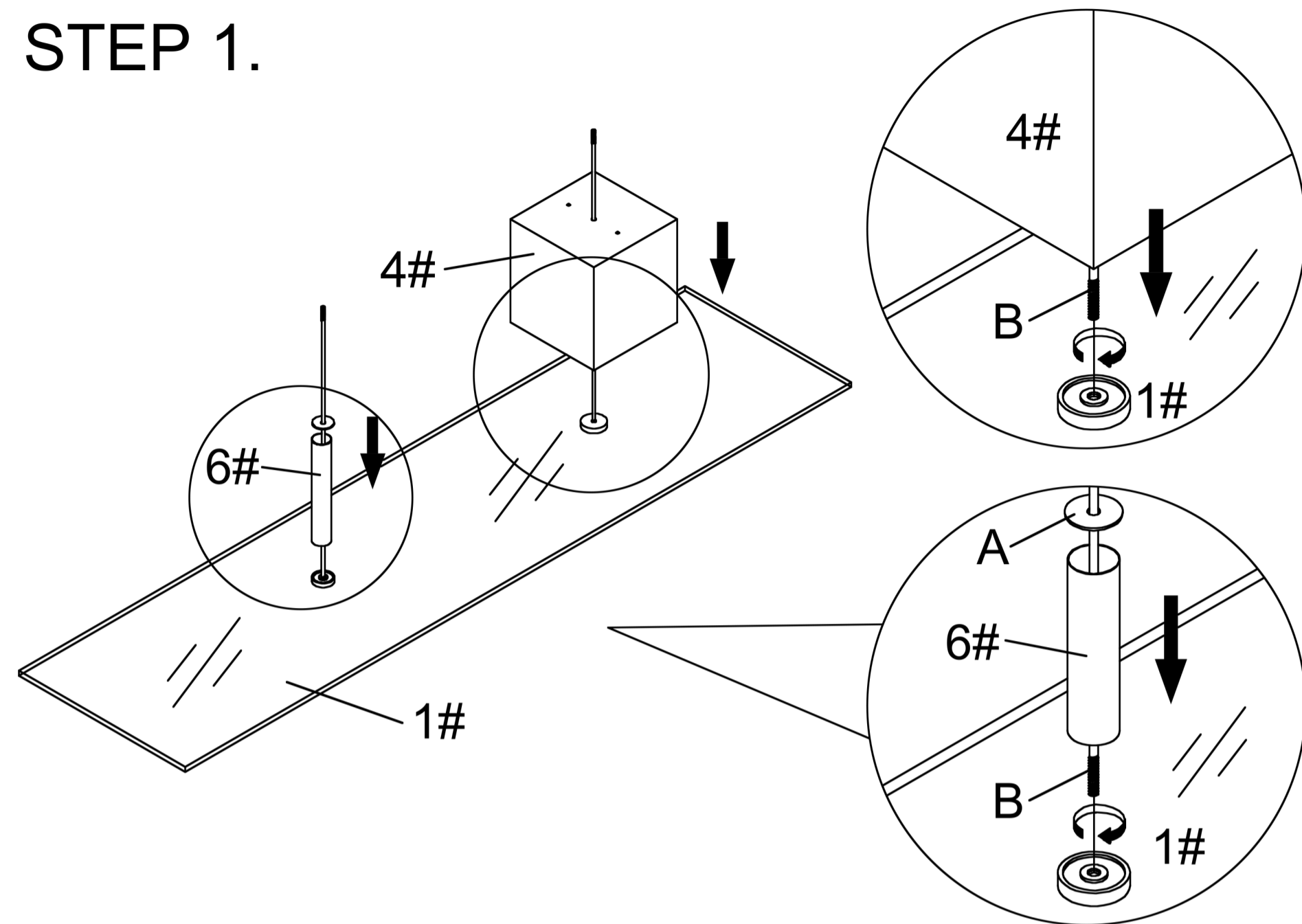

STEP 3.

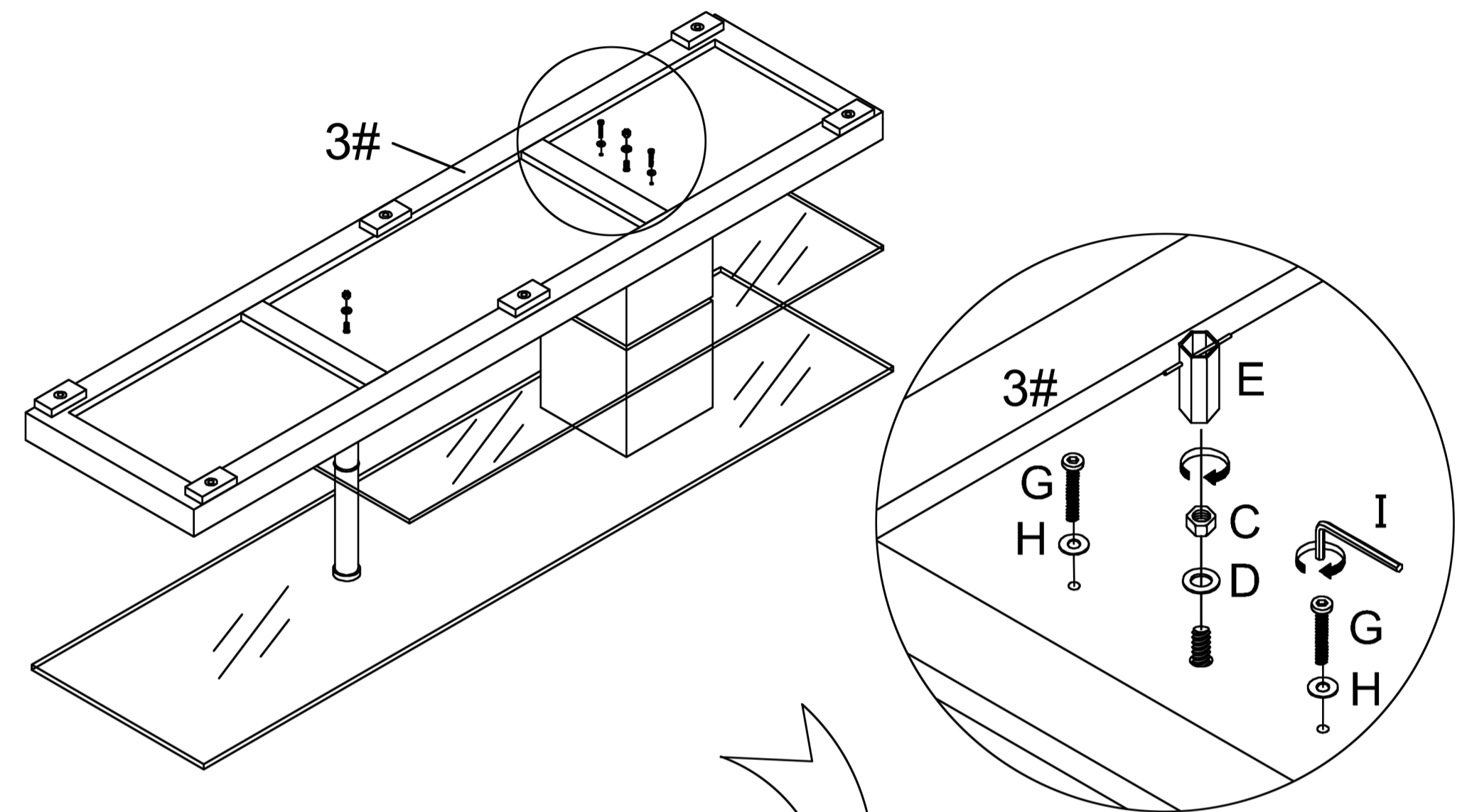

STEP 2.

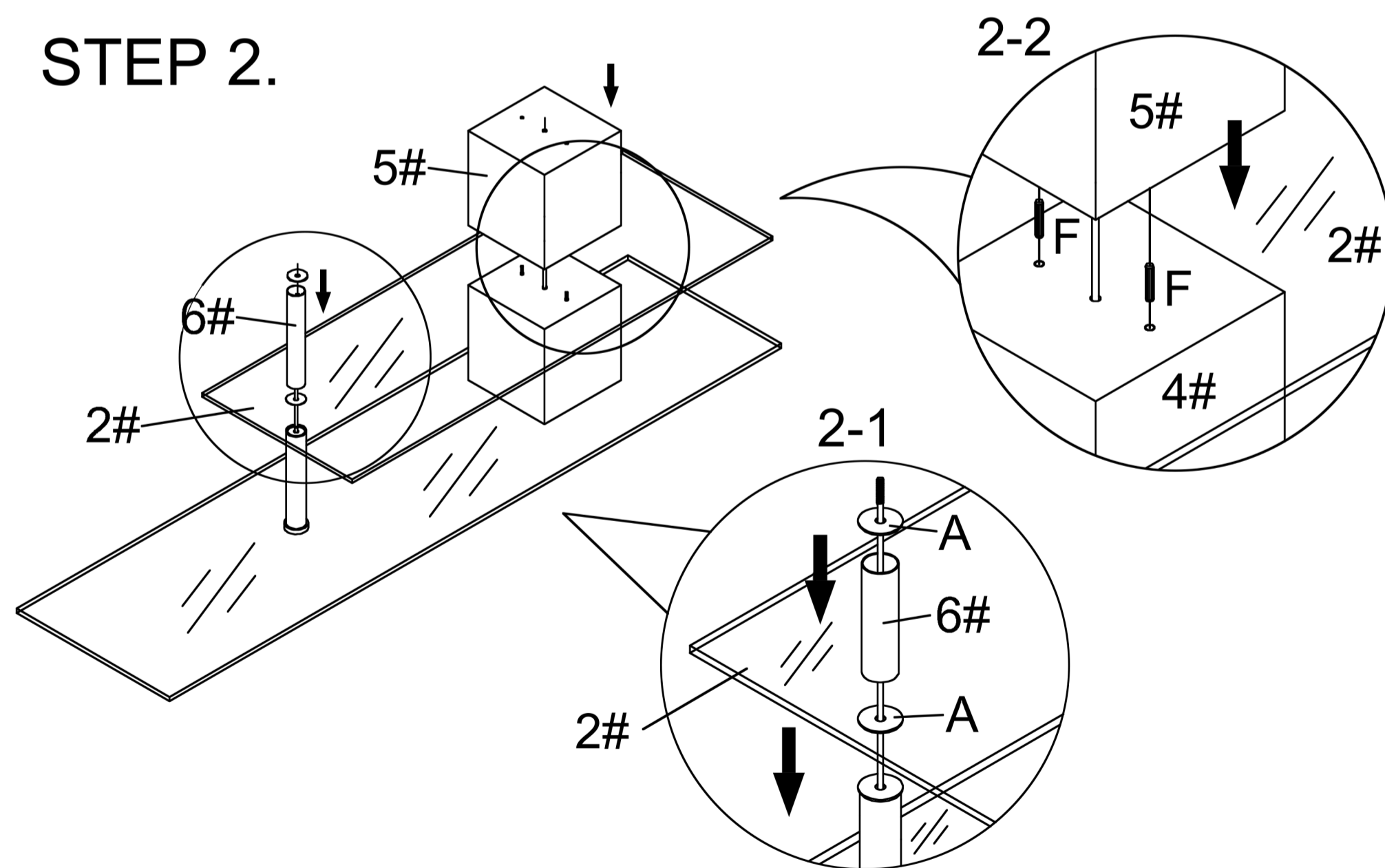

STEP 4.

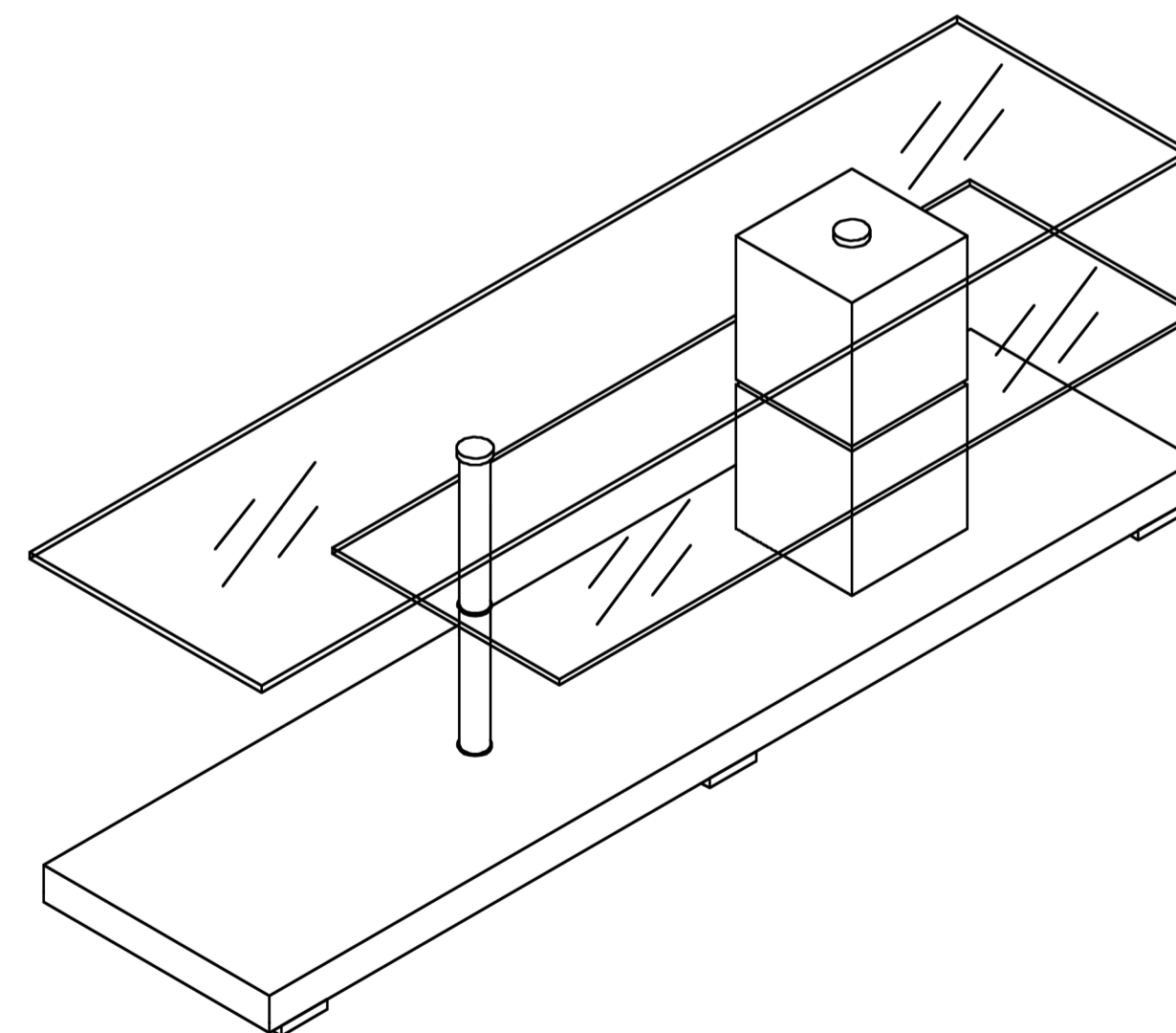

**Do not tighten screws until completely assembled.**

**Do not tighten screws until completely assembled.**