

ASSEMBLY INSTRUCTIONS

BENCH

**Note: Maximum Capacity- 2 person,
300lbs per seat**

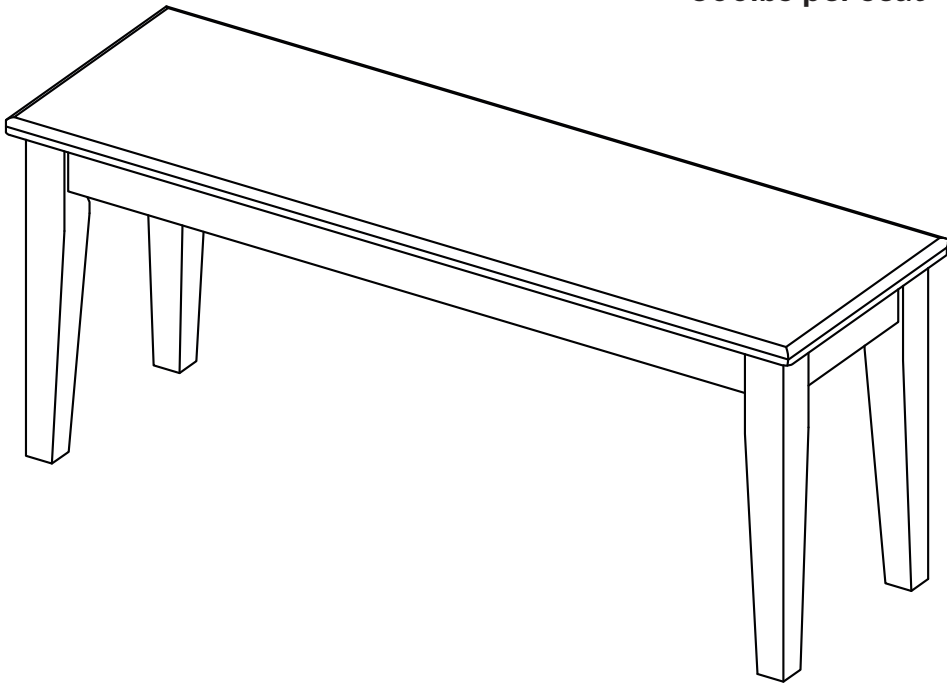

- All required tools for assembly are included unless noted.
- Locate and inspect all parts for missing items or damage prior to assembly.
- Do not dispose of packing materials until assembly is completed.
- Assemble item on a soft, clean surface to prevent damage to the item.
- Proper assembly requires 2 people.

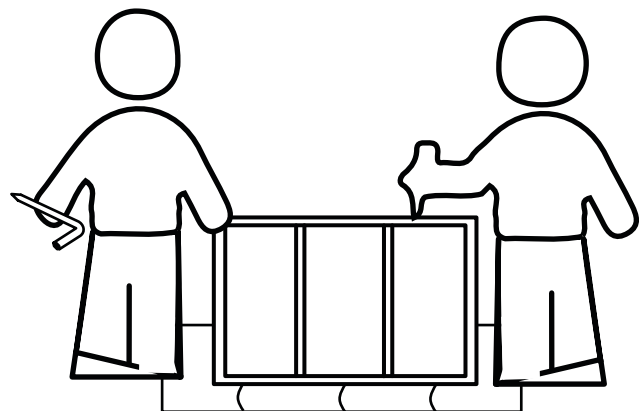
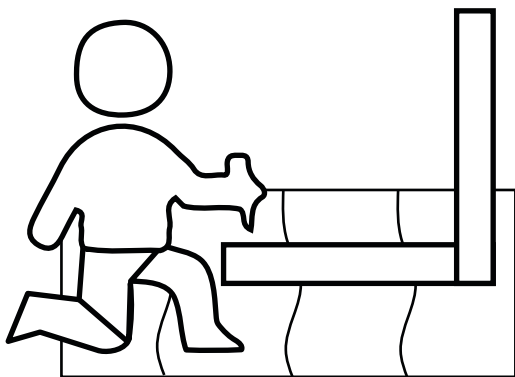
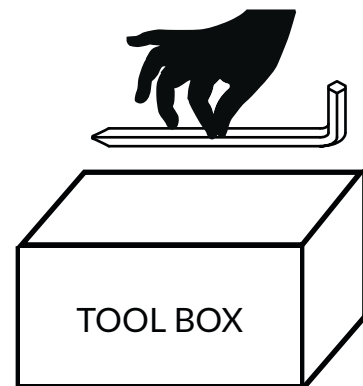

Assembly Overview

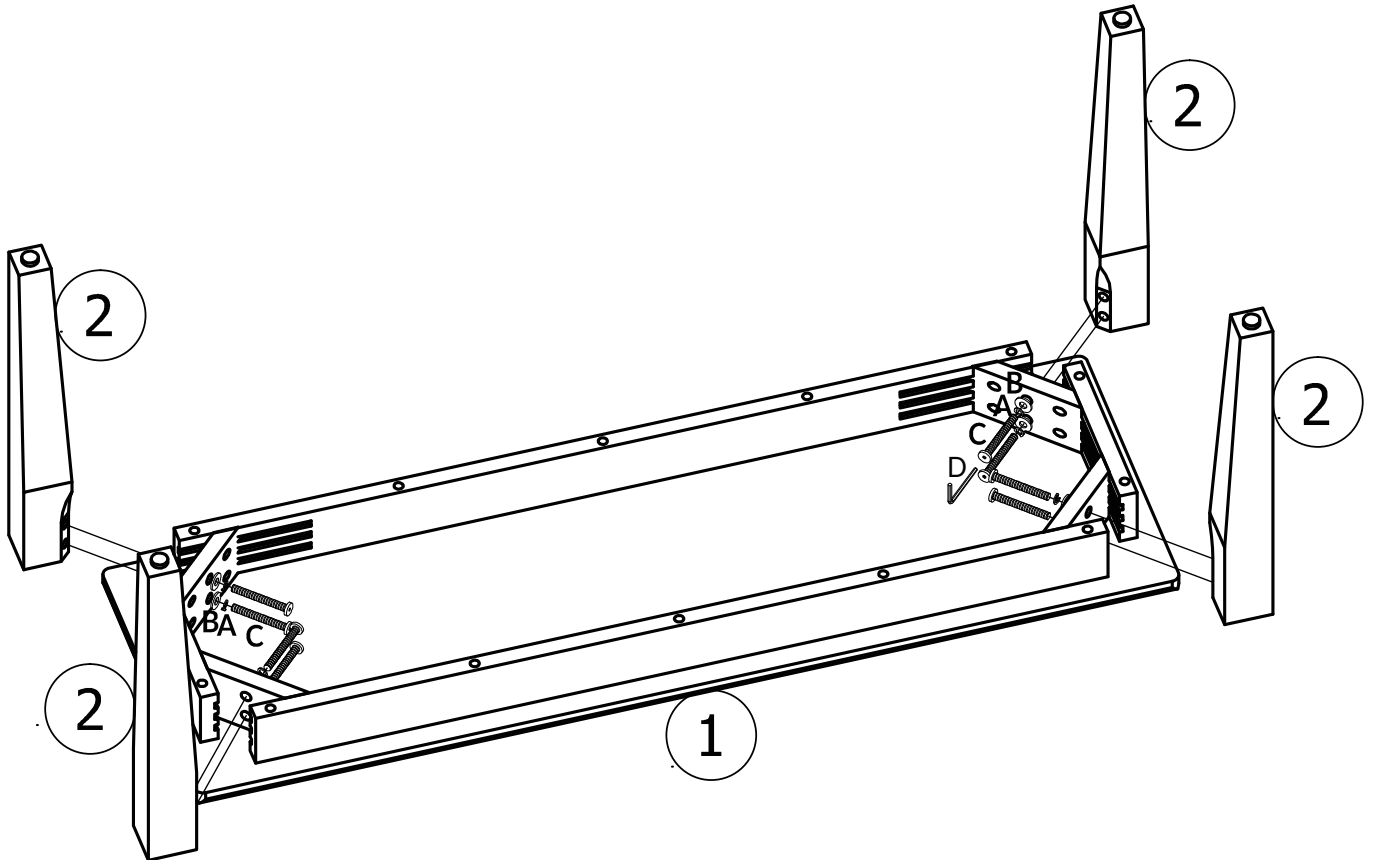

PARTS

① (x1)

Seat:

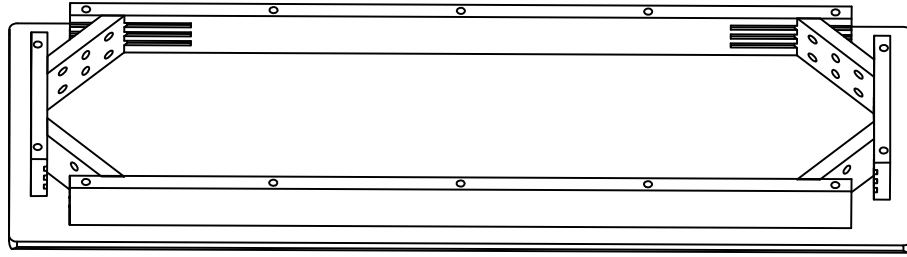

② (x4)

Leg:



HARDWARE

Ⓐ (x8)

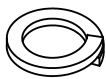

Spring Washer

Ⓑ (x8)

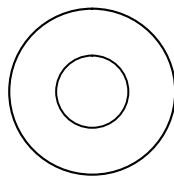

Flat Washer

Ⓒ (x8)

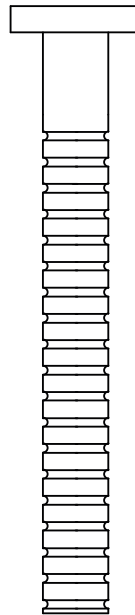

Bolt
M8x70

Ⓓ (x1)

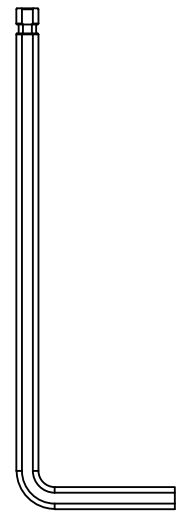

Allen
Wrench

01

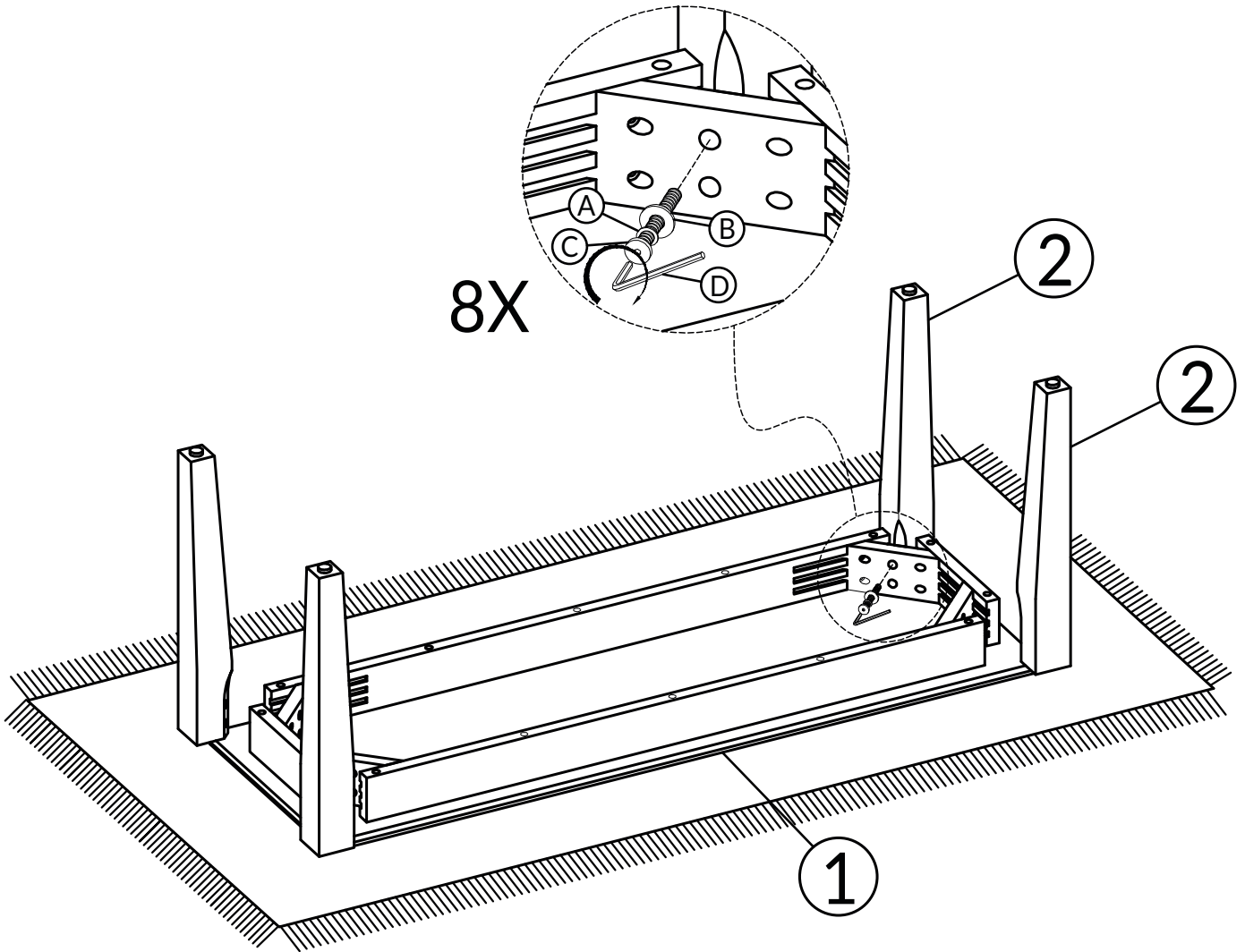

Hardware	Count
A	8
B	8
C	8
D	1

TIGHTEN BOLT COMPLETELY.

**Note: Maximum Capacity- 2 person,
300lbs per seat**

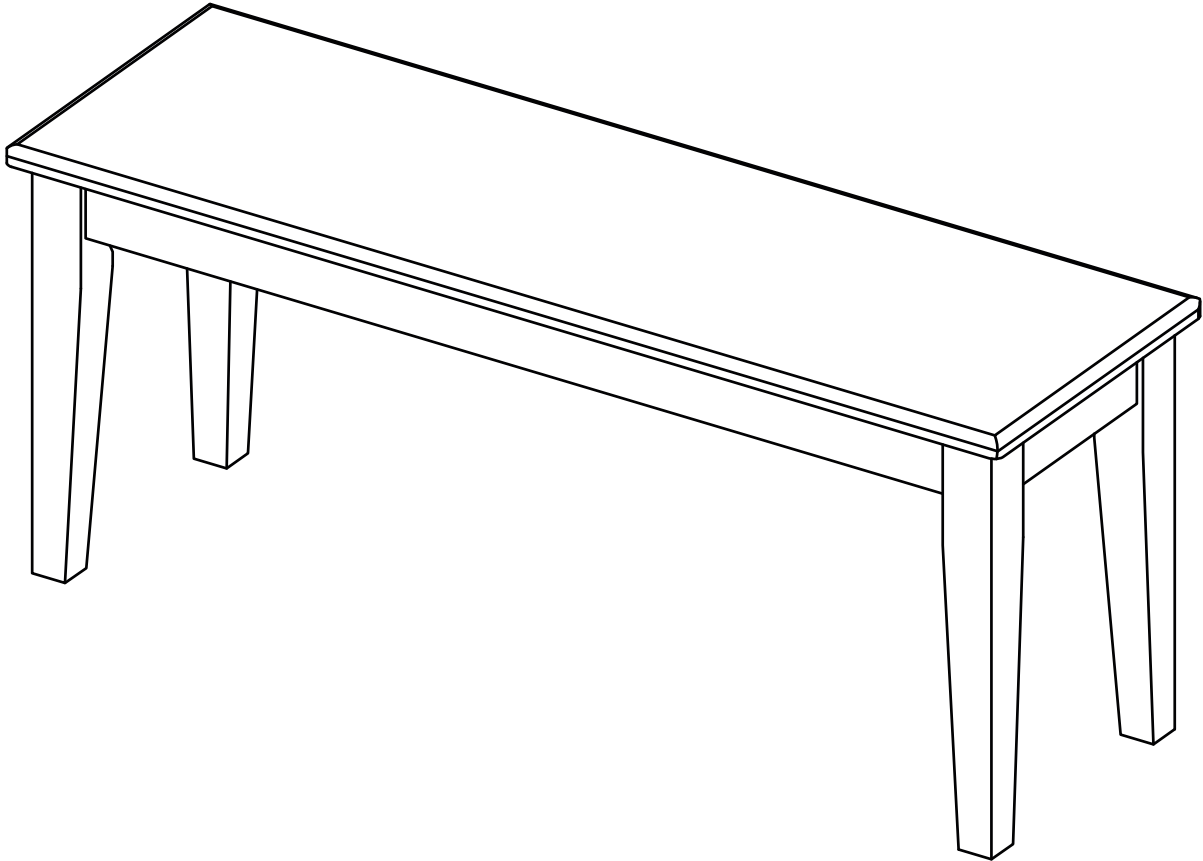

BE SURE TO CHECK ALL BOLTS ARE SECURELY TIGHTENED PRIOR TO USE.

ASSEMBLY INSTRUCTIONS

DINING CHAIR

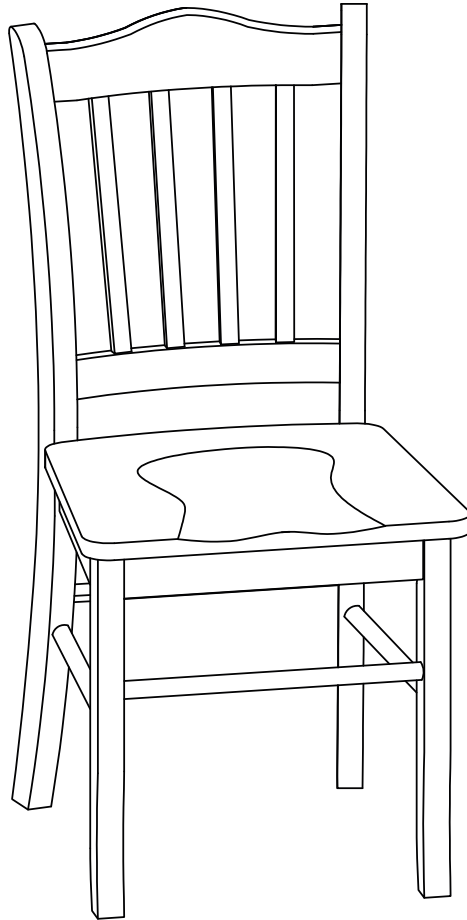

Weight Capacity



Philips screwdriver
not included.



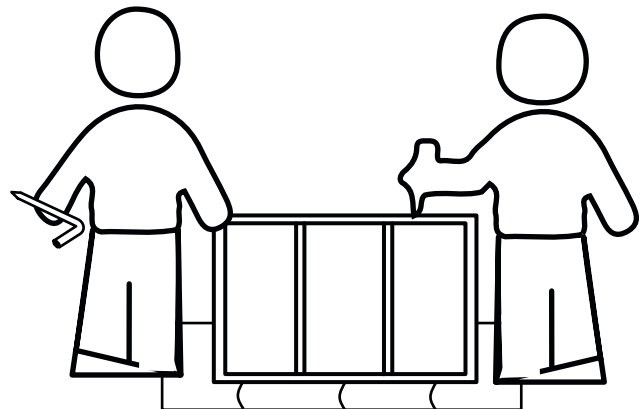
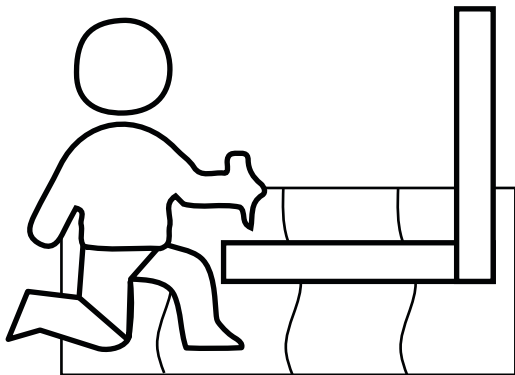
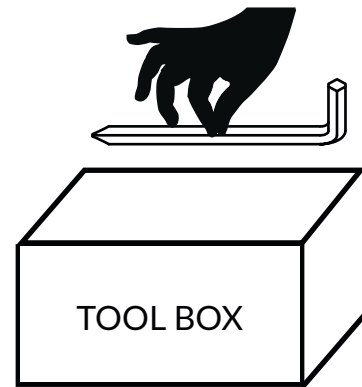

- All required tools for assembly are included unless noted.
- Locate and inspect all parts for missing items or damage prior to assembly.
- Do not dispose of packing materials until assembly is completed.
- Assemble item on a soft, clean surface to prevent damage to the item.
- Proper assembly requires 2 people.

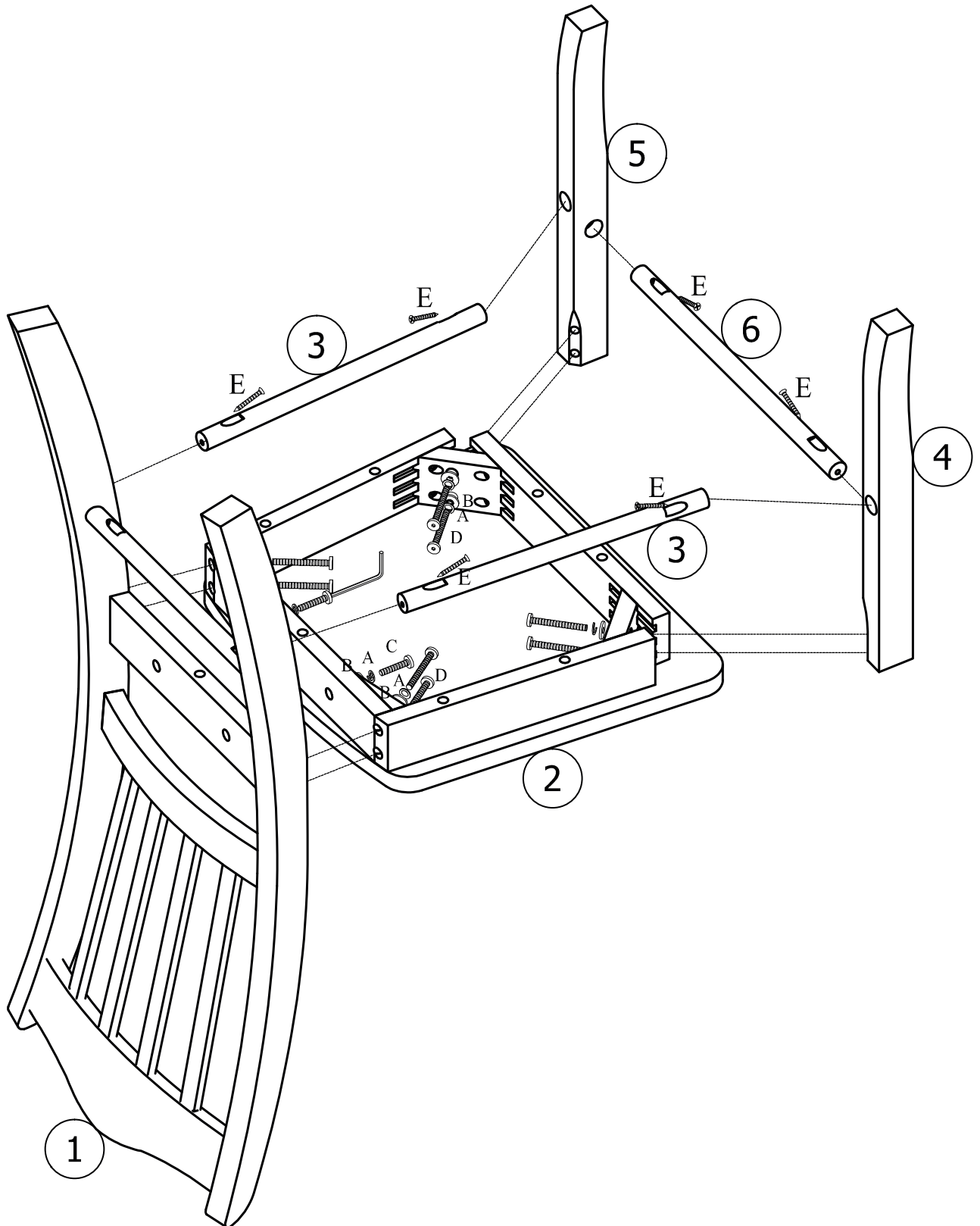

Assembly Overview

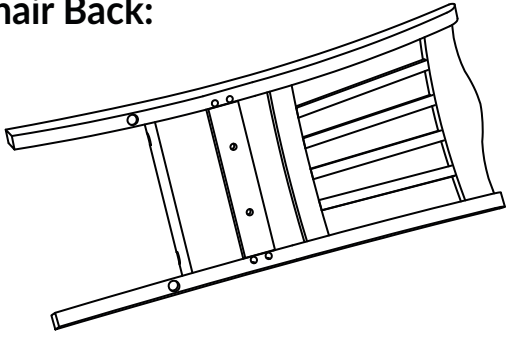
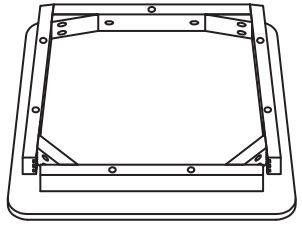

PARTS

① (x1)		② (x1)	
Chair Back: 		Seat Frame: 	
③ (x2)	④ (x1)	⑤ (x1)	⑥ (x1)
Side Stretcher: 	Leg-Left: 	Leg-Right: 	Footrest: 

HARDWARE

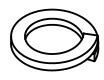
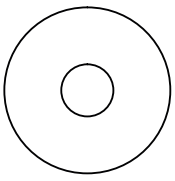
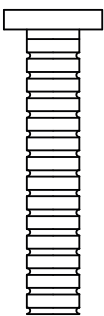
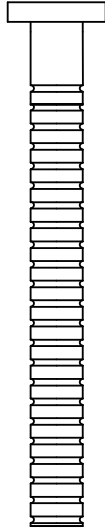
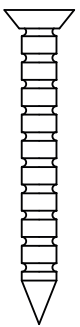
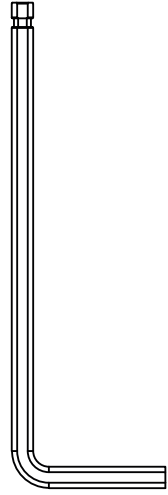
Ⓐ (x10)	Ⓑ (x10)	Ⓒ (x2)	Ⓓ (x8)	Ⓔ (x6)	Ⓕ (x1)
					
Spring Washer	Flat Washer	Bolt M6x35	Bolt M6x60	Screw M4x35	Allen Wrench

01

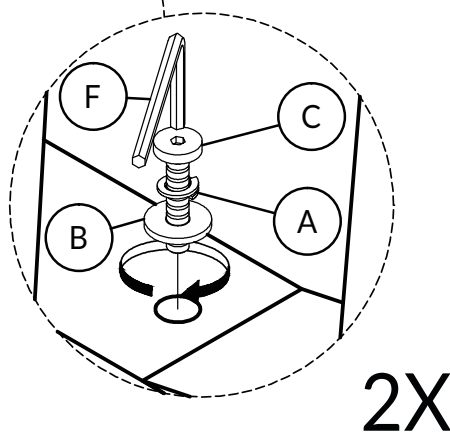
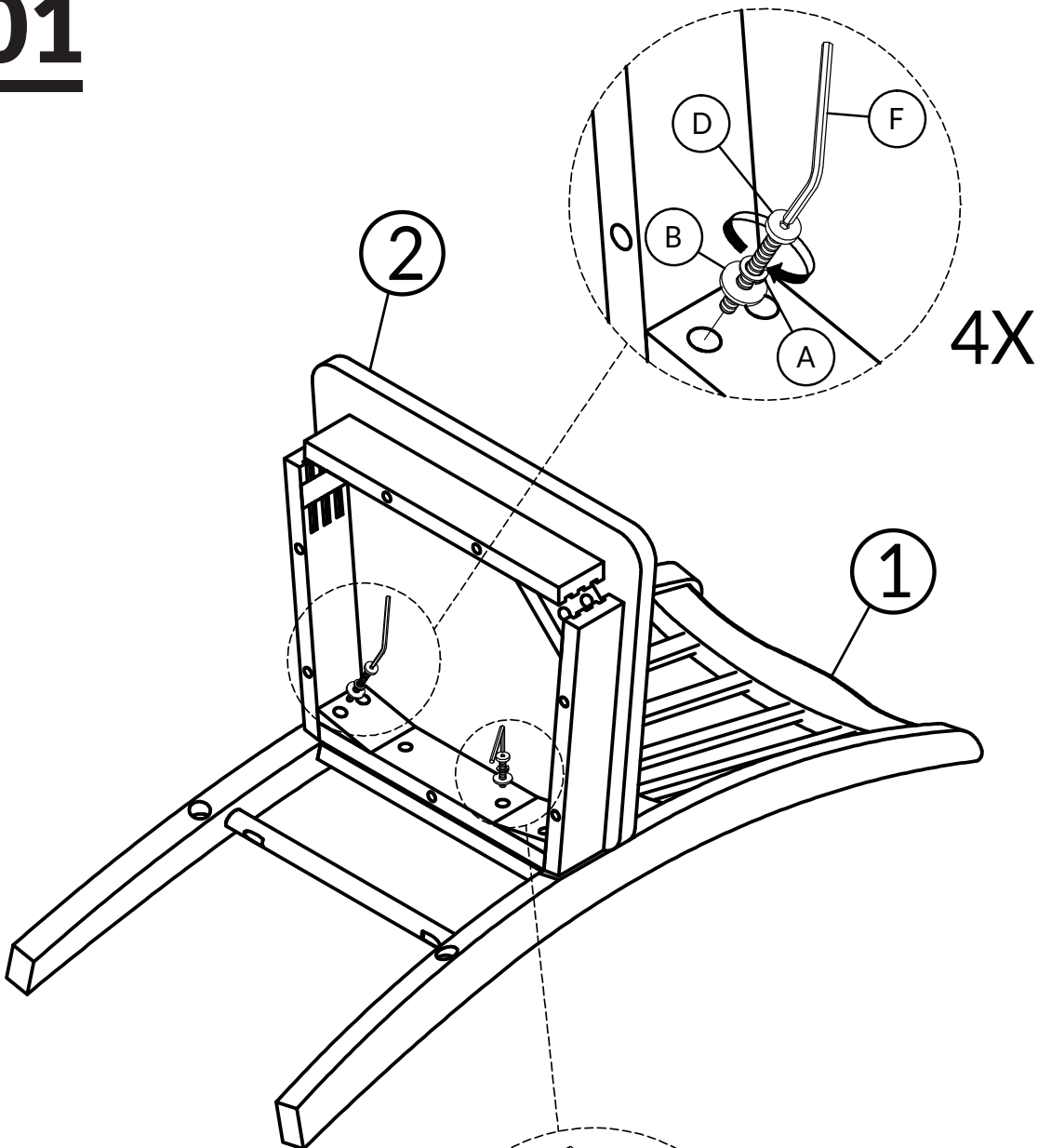

Hardware	Count
A	6
B	6
C	2
D	4
F	1

DO NOT TIGHTEN BOLT COMPLETELY.

02

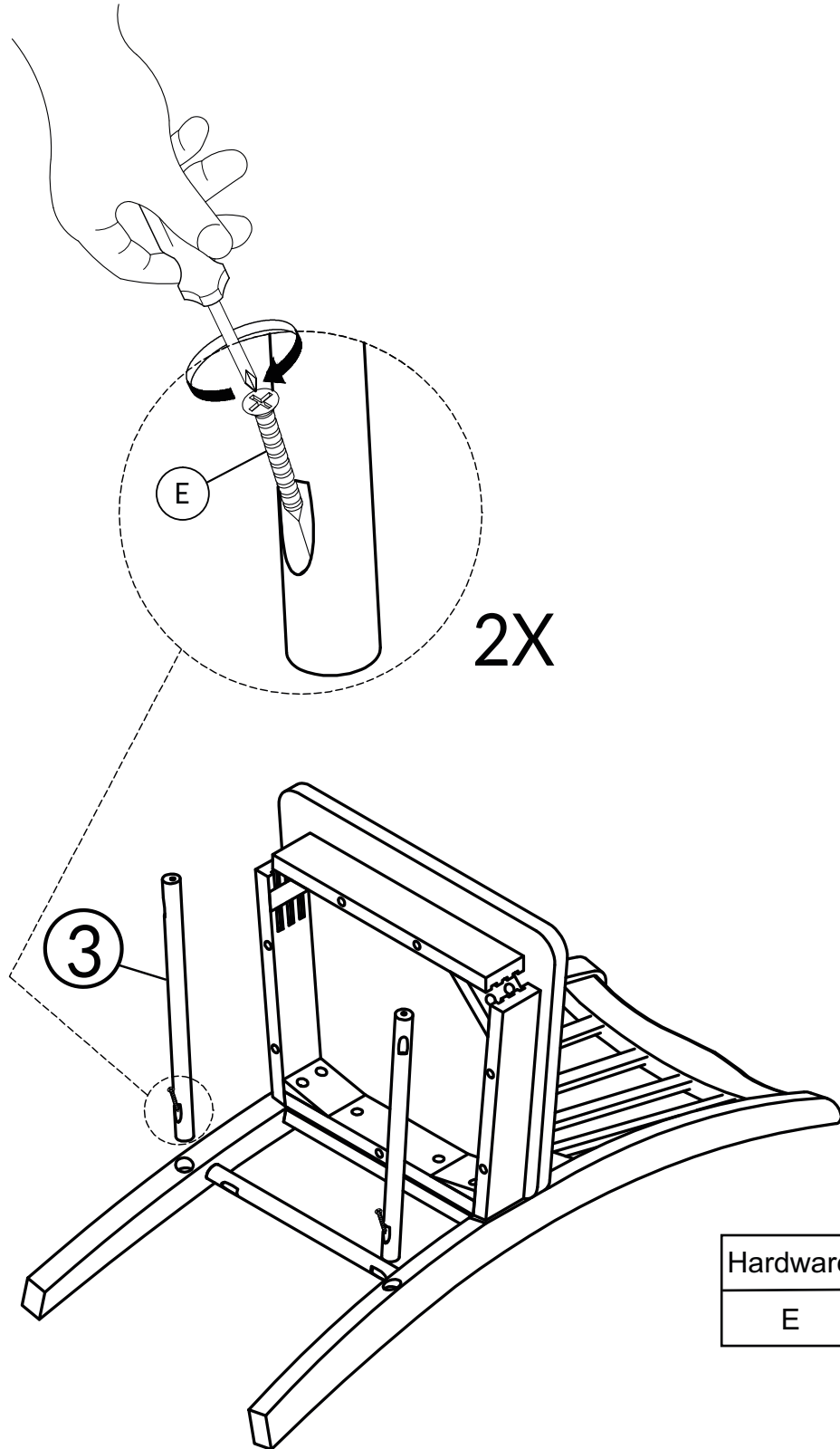

Hardware	Count
E	2

DO NOT TIGHTEN SCREW COMPLETELY.

03

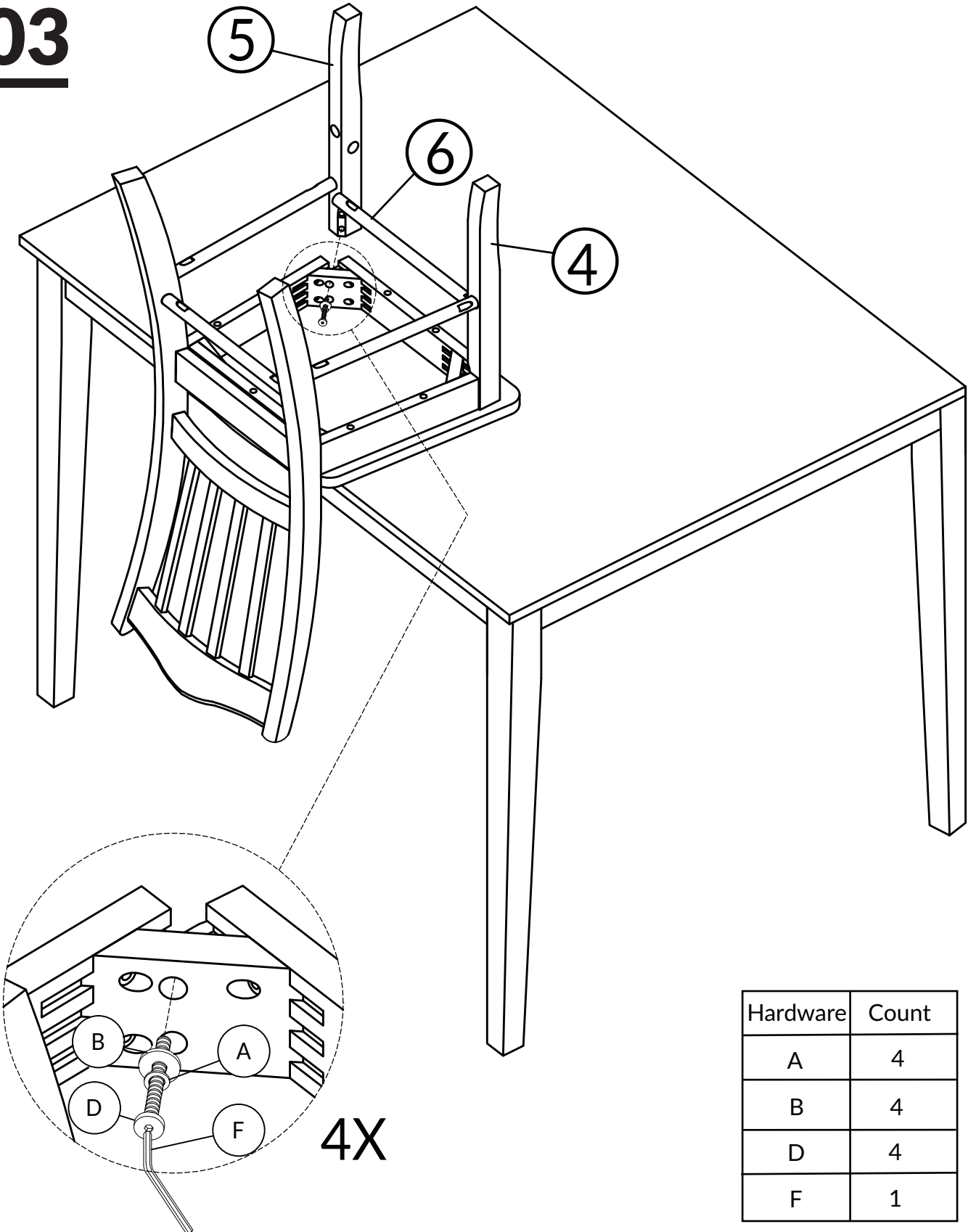

Hardware	Count
A	4
B	4
D	4
F	1

DO NOT TIGHTEN BOLT COMPLETELY.

04

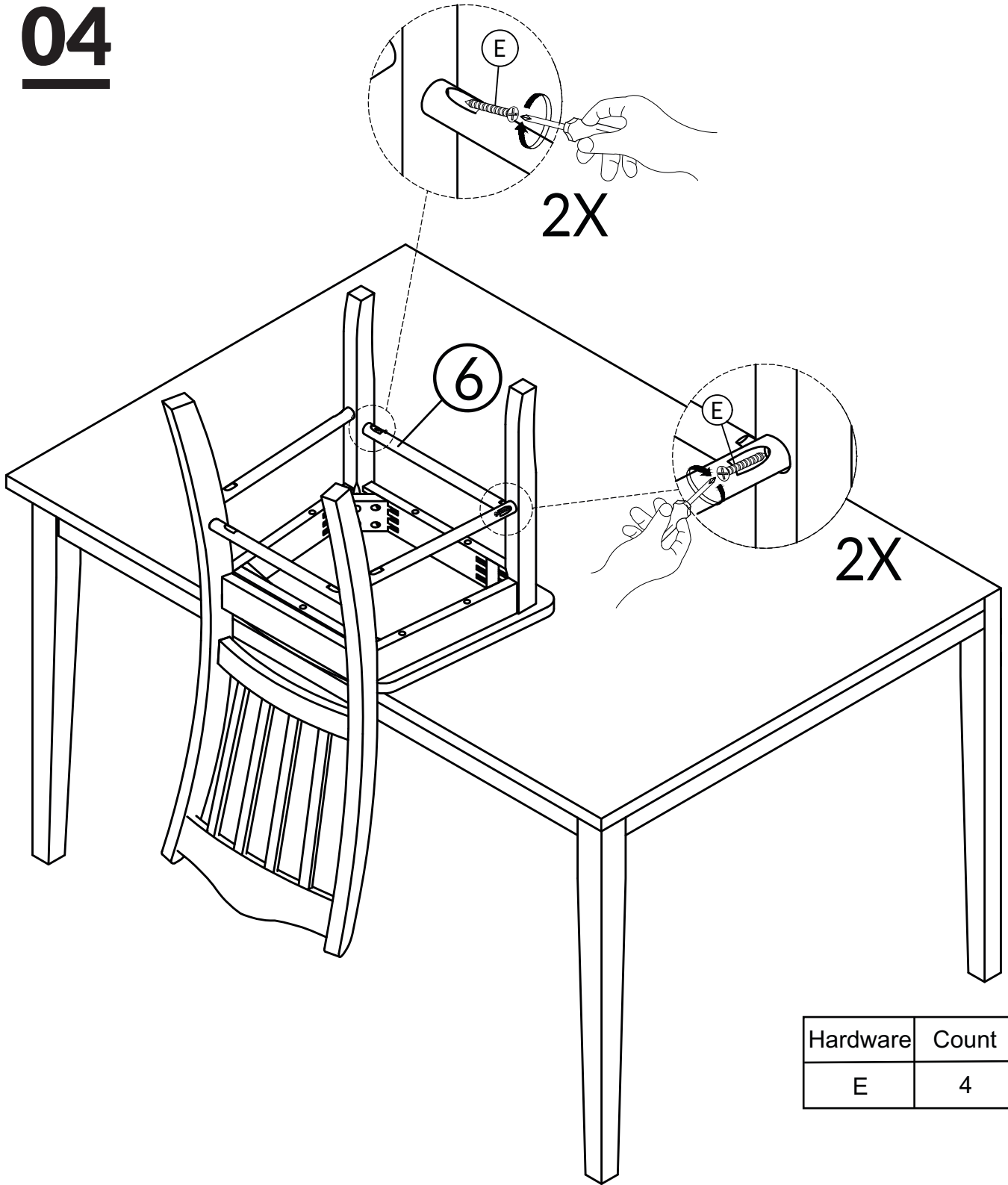

TIGHTEN BOLT AND SCREW COMPLETELY.

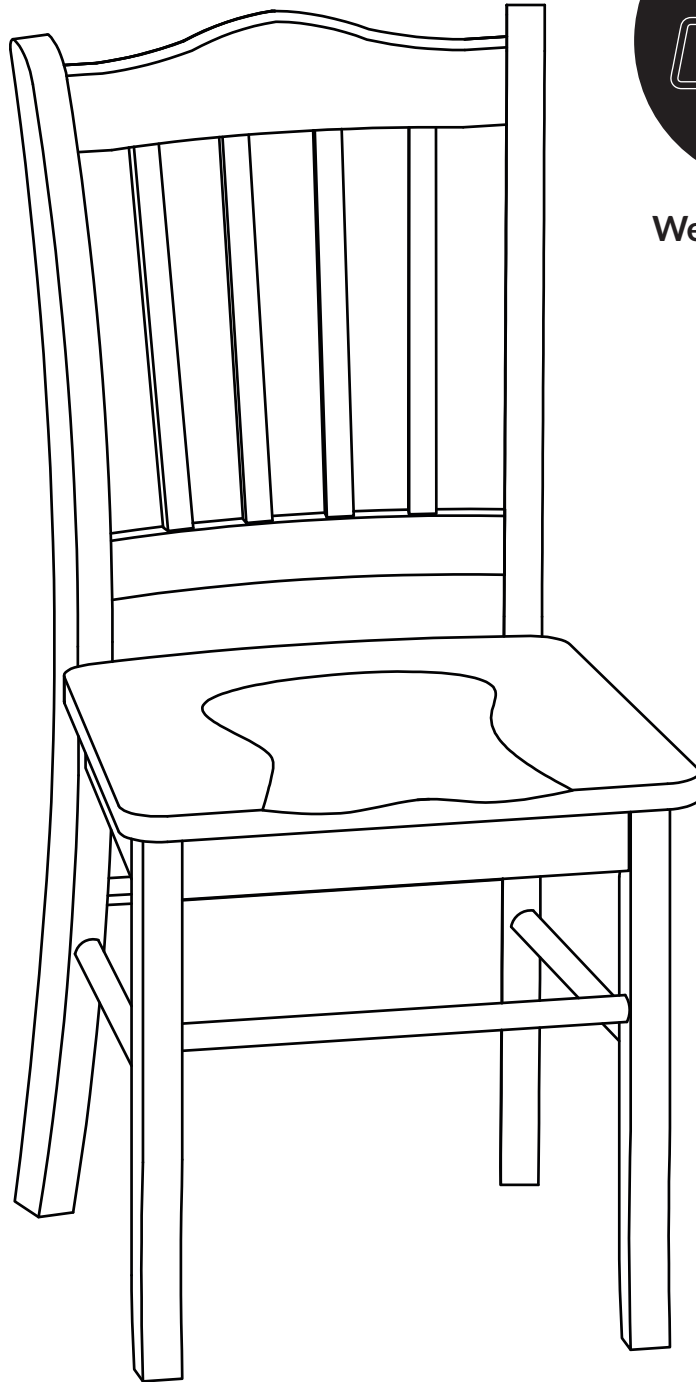

Weight Capacity

BE SURE TO CHECK ALL BOLTS ARE SECURELY TIGHTENED PRIOR TO USE.

ASSEMBLY INSTRUCTIONS

TABLE



Weight Capacity

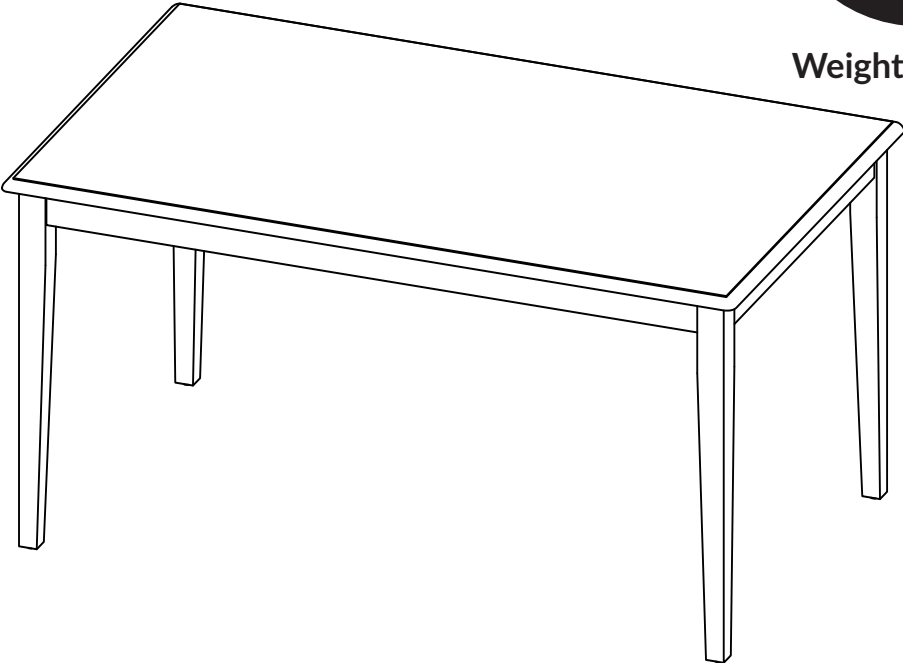



Philips screwdriver
not included.

- All required tools for assembly are included unless noted.
- Locate and inspect all parts for missing items or damage prior to assembly.
- Do not dispose of packing materials until assembly is completed.
- Assemble item on a soft, clean surface to prevent damage to the item.
- Proper assembly requires 2 people.

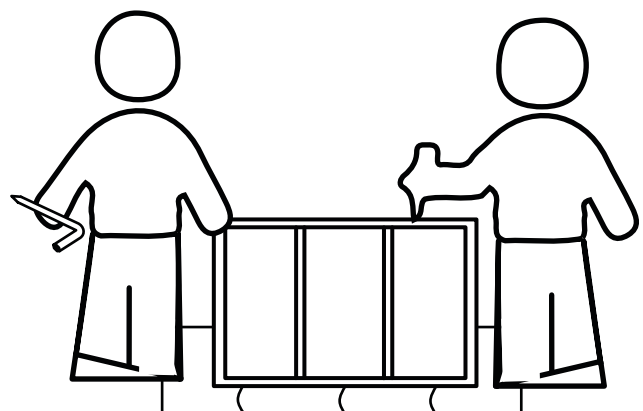
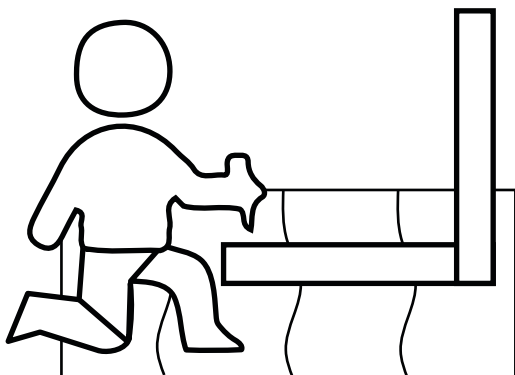
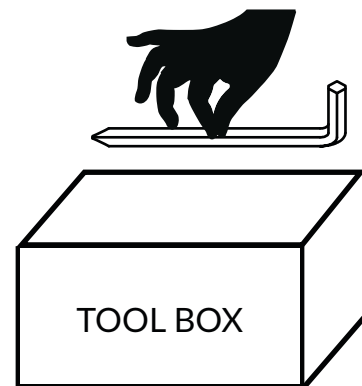

Assembly Overview

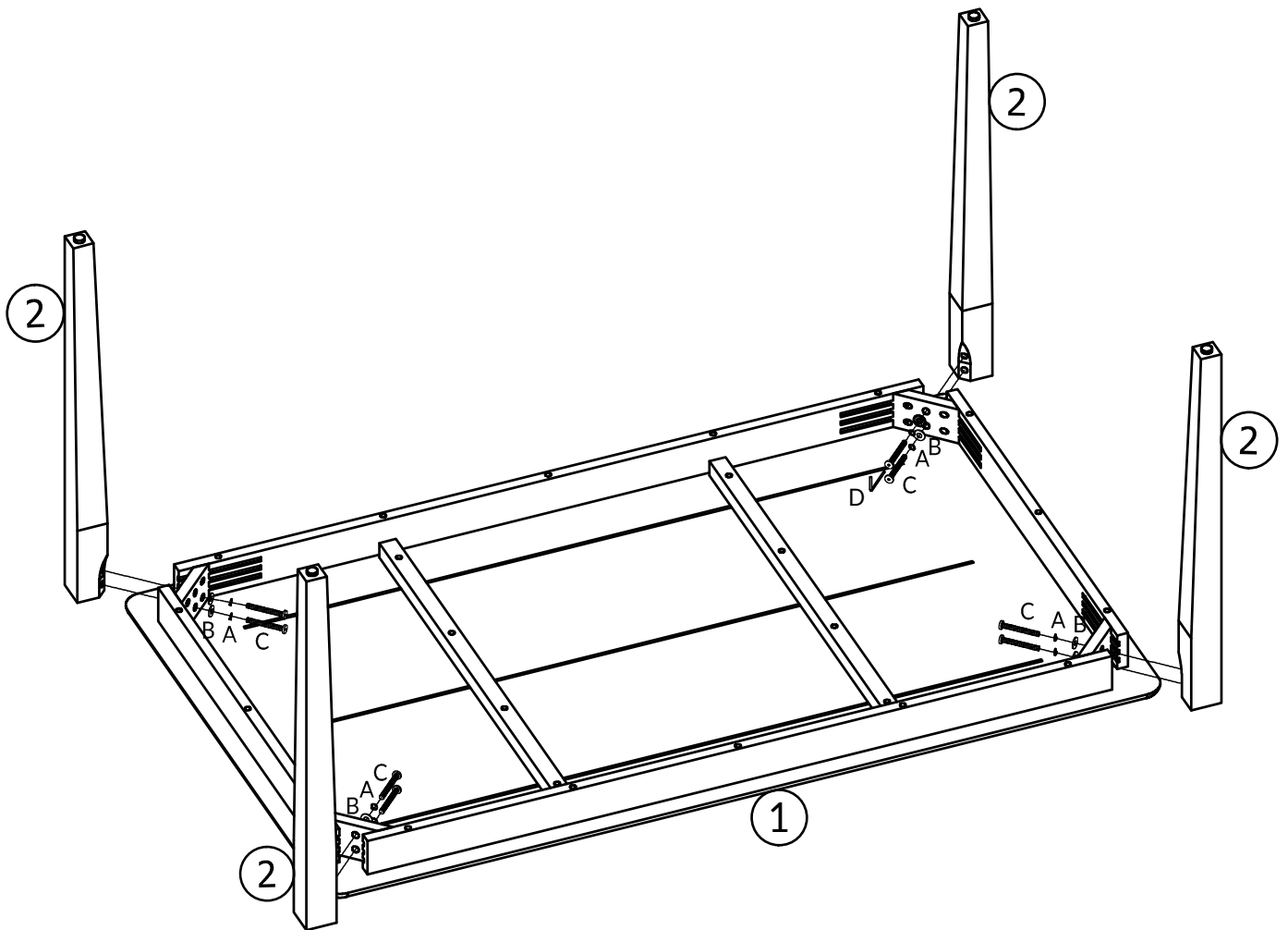

PARTS

① (x1)

Top Panel :

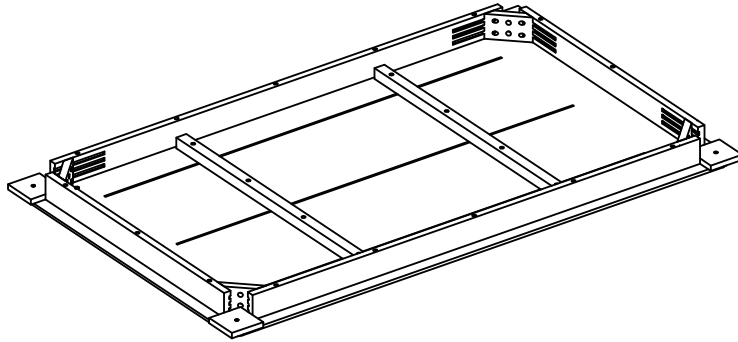

② (x4)

Leg :



HARDWARE

Ⓐ (x8)

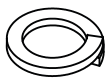

Spring Washer

Ⓑ (x8)

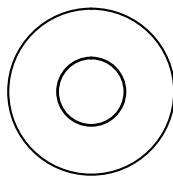

Flat Washer

Ⓒ (x8)

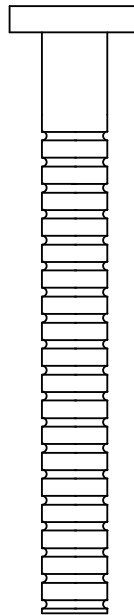

Bolt
M8x70

Ⓓ (x1)

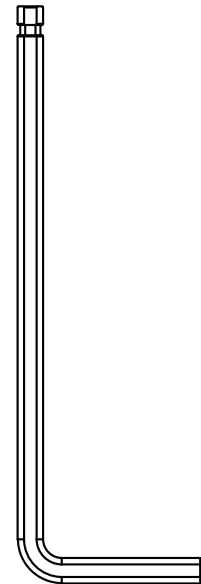

Allen
Wrench

01

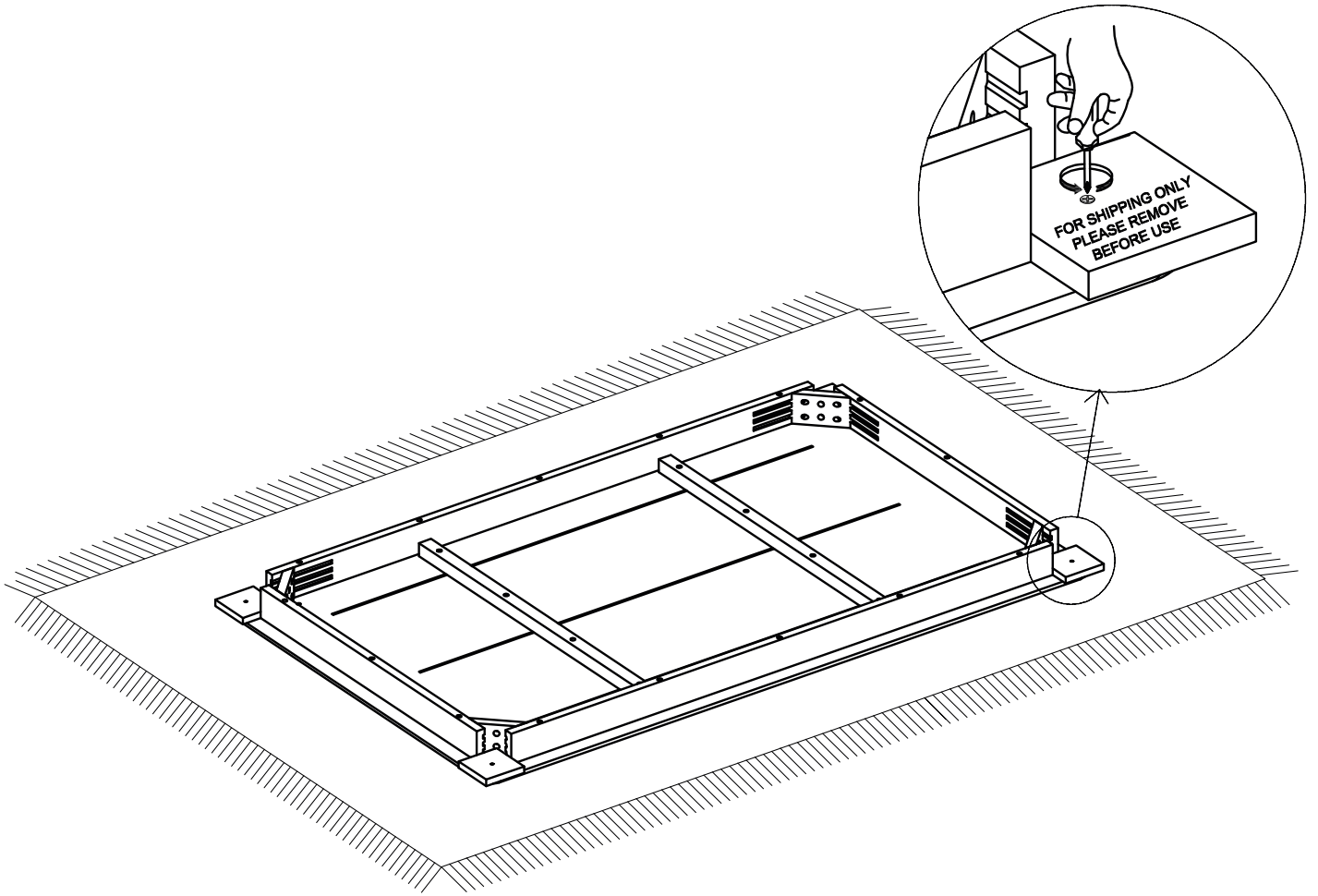

02

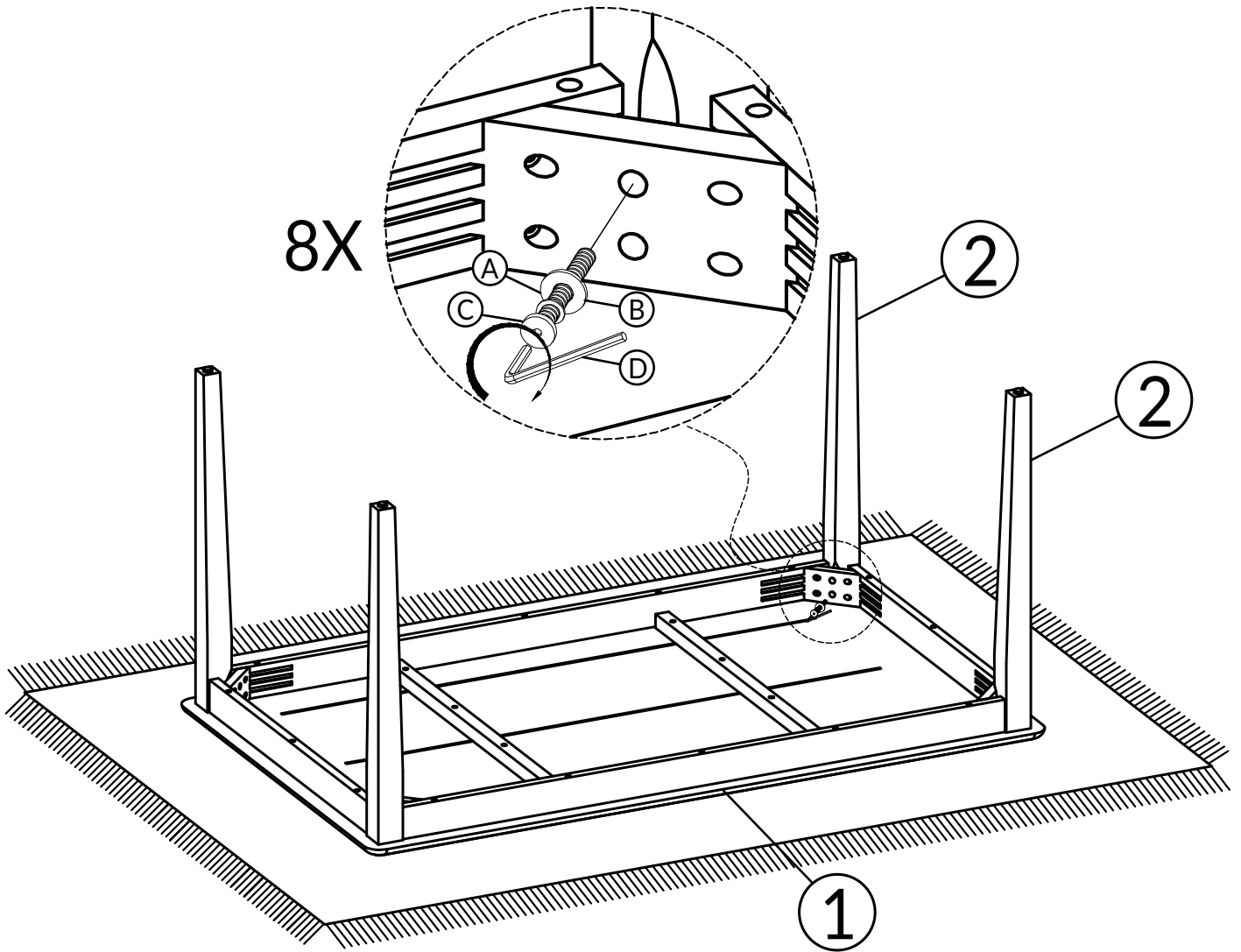

Hardware	Count
A	8
B	8
C	8
D	1

TIGHTEN BOLT COMPLETELY.



Weight Capacity

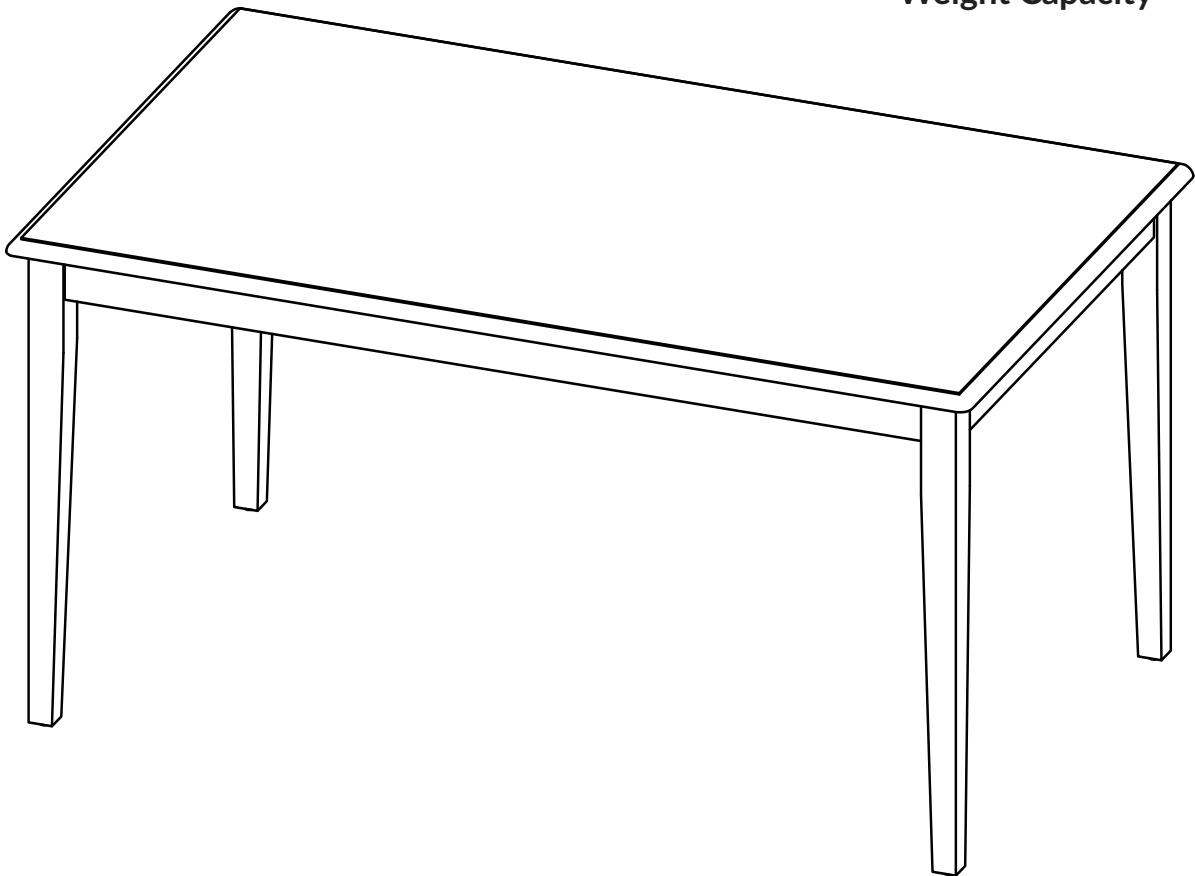

BE SURE TO CHECK ALL BOLTS ARE SECURELY TIGHTENED PRIOR TO USE.