

ASSEMBLY INSTRUCTIONS

**ASSEMBLY
REQUIREMENTS**

**1-Person
Assembly**

**Assembly Time
(Approximate)**

45 Minutes

Thank you for purchasing our product!

Please refer and use this assembly instruction to assemble the product. Contact our customer service department in case there are any missing or damage parts or hardware. Replacement parts are normally shipped within 2 or 3 days.

**PRODUCTS PURCHASED THROUGH OUR AUTHORIZED VENDORS
ONLY ARE ELIGIBLE FOR REPLACEMENT PARTS**

We appreciate your business!

**THIS PRODUCT IS FOR INDOOR AND HOUSEHOLD USE ONLY
– NOT FOR COMMERCIAL USE.**

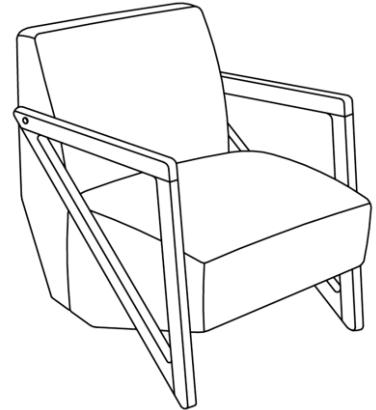

ASSEMBLY PREPARATION

1. Remove all packaging materials, staples and packing straps from the carton.
2. Refer to Parts List and Hardware List, and ensure parts and hardware are correct before assembly. Contact customer service for missing parts.
3. Place all wooden parts on a clean, flat and soft surface (e.g. carpet or rug) to prevent scratch and damage to parts.

SAFETY PRECAUTION

1. KEEP ALL HARDWARE PARTS OUT OF REACH OF CHILDREN.
2. DISPOSE PLASTIC PACKAGING MATERIAL IMMEDIATELY TO AVOID ANY RISK OF SUFFOCATION TO CHILDREN AND ANIMALS.

TIPS FOR ASSEMBLY



1. Allow ample room for assembly and assemble the product near where the product will be placed.
2. Assemble the product on a surface that does not scratch or damage the exterior gloss and finish of the furniture.
3. Identify all of the parts, hardware and quantities required for each step.
4. During assembly, do not over-tighten any fittings as this may cause damage.
5. **DO NOT USE POWER TOOLS TO ASSEMBLE THIS PRODUCT.**
6. Always place the product on a flat, level surface.
7. Do not sit or stand on the partially assembled product; only use the product for which it is intended.

CARE AND MAINTENANCE

- Use a slightly damp cloth to clean the product. Do not use bleach or abrasive cleaning material.
- Check all the fittings periodically and re-tighten as necessary. Do not use the product if any of the parts is damaged or broken.
- Never allow any kind of liquid to remain on your furniture. Absorption can cause wood to warp or delaminate.
- Do not place hot items (e.g. hot drinks) directly onto the wood surface.
- Do not drag and/or pull the furniture.

ASSEMBLY INSTRUCTIONS

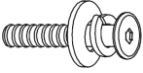
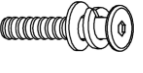
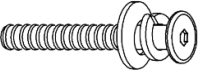
HARDWARE LIST

Item	Description	Part	Qty	Extra
A	JCBC Bolt M6x35mm + Spring Washer M6 + Flat Washer M6x19mm		4	1
B	JCBC Bolt M6x35mm + Spring Washer M6 + Flat Washer M6x13mm		2	1
C	JCBC Bolt M6x40mm + Spring Washer M6 + Flat Washer M6x19mm		4	1
D	Allen Key M4		1	
E	Wood Button \varnothing 14.5		2	1

PARTS LIST

Item	Description	Qty
1	Armrest (Left & Right)	2
2	Chair Seat	1
3	Chair Backrest	1

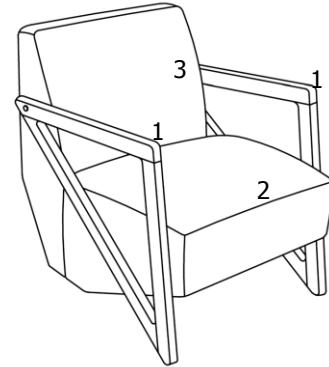

***EXTRA HARDWARE FOR SPARE USE**

STEP 1

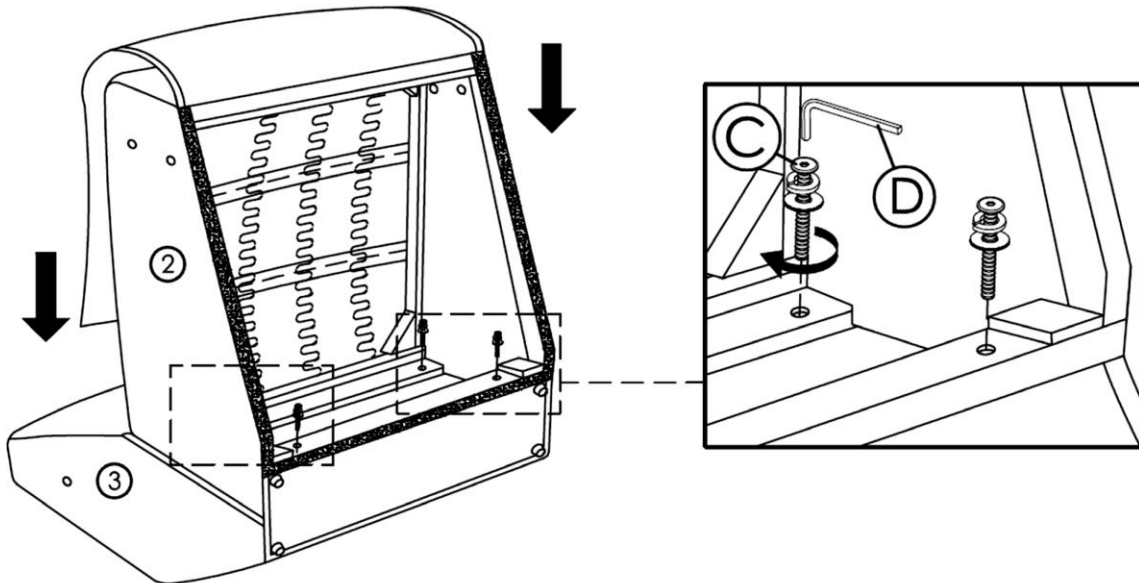

- Place Chair Backrest (3) on a material that does not damage or dirty the part.
- Detach the cover on the bottom of Chair Seat (2) and position (2) on (3) as shown and align the bolt holes on each part.
- Use Bolt (C) to fasten (2) to (3). Use Allen Key (D) to drive (C). Do not tighten (C) completely until all 4 bolts are in place. Do not over-tighten.

STEP 2

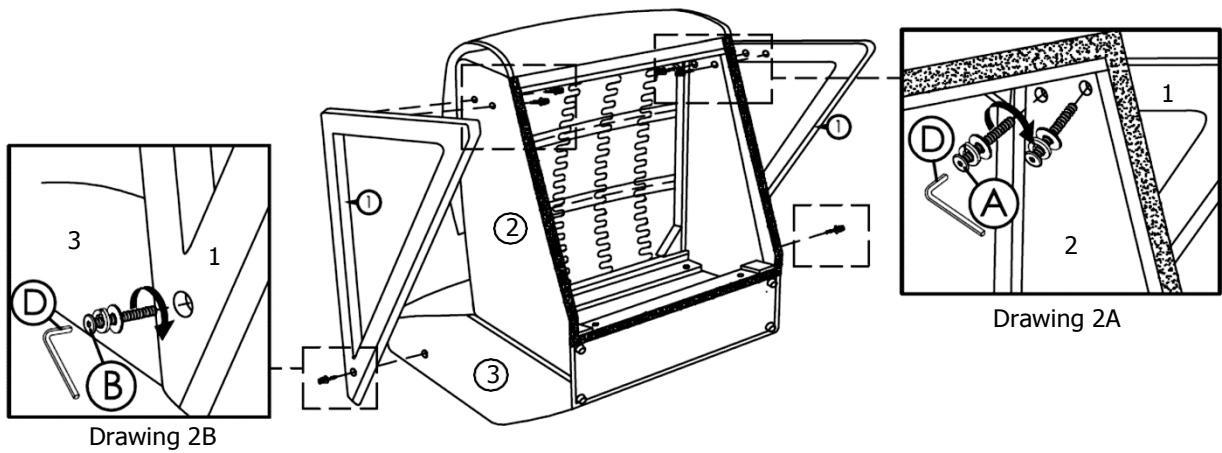

- Position Armrest (1) on each side of the Chair Seat (2) & Backrest (3) assembly as shown.
- Refer to Drawing 2A – align the bolt holes on (1) and (2) and fasten with Bolt (A). Use Allen Key (D) to drive (A). Loosely fasten (A) – do not tighten (A) at this time.
- Refer to Drawing 2B – align the bolt holes on (1) and (3) and fasten with Bolt (B). Use Allen Key (D) to drive and tighten (B) completely. Tighten (A) completely at this time. Do not over-tighten.

STEP 3

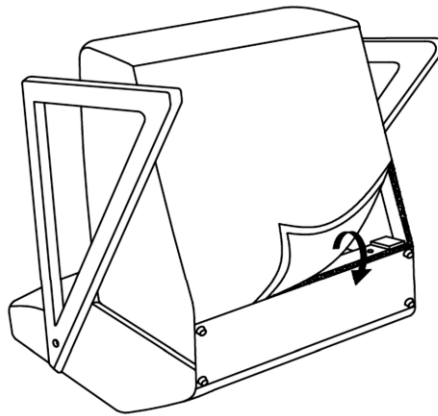

Re-attach the cover squarely to the bottom of Chair Seat.

STEP 4

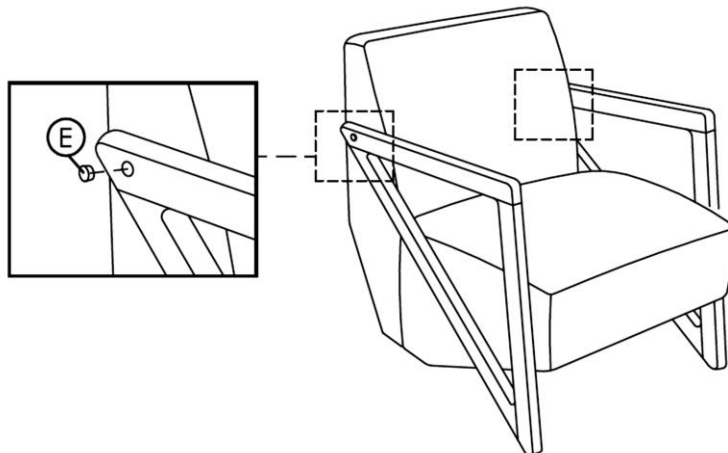

Set the chair right-side up.
Use Wood Button (E) to conceal bolt holes on Chair Armrest.
The Assembly of the chair is complete.