

ASSEMBLY INSTRUCTION
INSTRUCTIONS DE MONTAGE

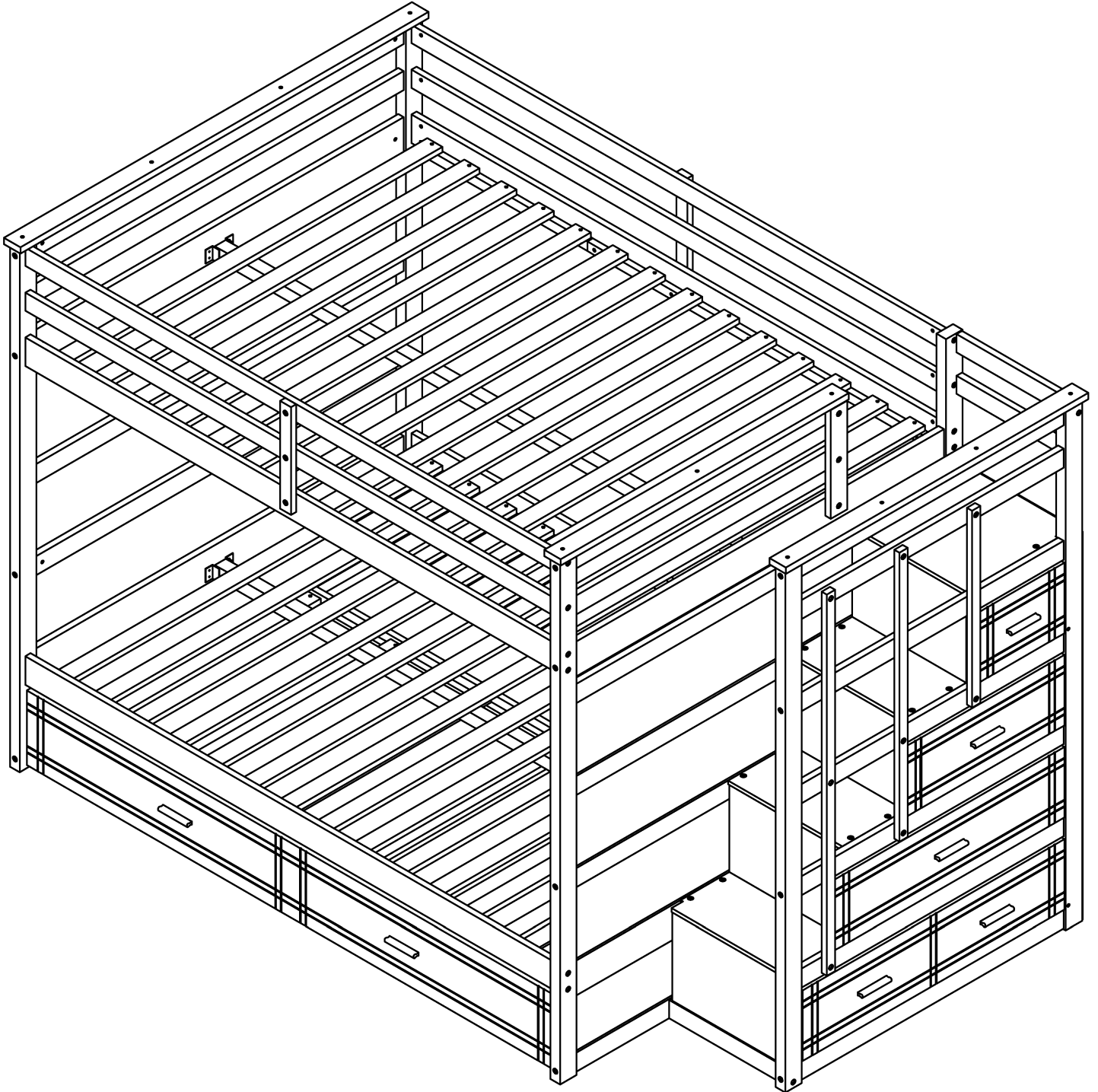

! SAFETY WARNINGS !

1. This bed is designed for use only mattress (es) meeting the following specifications on the upper bunk, and lower bunk

Upper bed

Bed Type	Length	Width	Thickness
<i>Full Standard</i>	<i>74" - 75"</i>	<i>53 1/2"</i>	<i>6" max</i>

Lower bed

Bed Type	Length	Width	Thickness
<i>Full Standard</i>	<i>74" - 75"</i>	<i>53 1/2"</i>	<i>8" max</i>

2. Replacement parts, including additional guardrails, maybe obtained from any of our dealers.
3. Follow the information on the warnings appearing on the upper bunk bed end structure and on the carton. Do not remove warning label from bed
4. Always use the recommended size mattresses or mattress supports, or both, to help prevent the likelihood of entrapment or falls.
5. Surface of mattress must be at least 5" (127mm) below the upper edge of guardrails
6. Do not allow children under 6 years of age to use the upper bunk.
7. Periodically check and ensure that the guardrail, ladder, and other components are in their proper position, free from damage, and that all connectors are tight.
8. Do not allow horseplay on or under the bed and prohibit jumping on the bed.
9. Always use the ladder for entering and leaving the upper bunk.
10. Do not use substitute part. Contact the manufacture or dealer for replacement part
11. Use of a night light may provide added safety precaution for a child using the upper bunk..
12. Always use guardrails on both long sides of the upper bunk. If the bunk bed will be placed next to the wall, the guardrail that runs the full length of the bed should be placed against the wall to prevent entrapment between the bed and wall.
13. The use of water or sleep flotation mattresses is prohibited
14. STRANGULATION HAZARD - Never attach or hang items to any part of the bunk bed that are not designed for use with the bed; for example, but not limited to, hook, belts and jump ropes
15. Keep these instruction for future reference
16. Prohibit more than one person on upper bunk
17. We recommend assembling your bunk bed on the shipping carton to protect your floor or carpet
18. Be certain all staples are out of the box before beginning assembly on the shipping carton.

! AVERTISSEMENTS DE SÉCURITÉ !

1. Ce lit est conçu pour utiliser uniquement des matelas répondant aux spécifications suivantes sur le lit supérieur, et couchette inférieure

Lit supérieur

Type de lit	Longueur	Largeur	Épaisseur
Full Standard	74" - 75"	53 1/2"	6" max

Lit inférieur

Type de lit	Longueur	Largeur	Épaisseur
Full Standard	74" - 75"	53 1/2"	8" max

2. Les pièces de rechange, y compris les garde-corps supplémentaires, peuvent être obtenues auprès de l'un de nos revendeurs.
3. Suivez les informations sur les avertissements apparaissant sur la structure d'extrémité supérieure du lit superposé et sur le carton. Ne retirez pas l'étiquette d'avertissement du lit
4. Utilisez toujours des matelas ou des supports de matelas de taille recommandée, ou les deux, pour éviter tout risque de coincement ou de chute.
5. La surface du matelas doit être à au moins 5" (127 mm) sous le bord supérieur des garde-corps.
6. Ne laissez pas les enfants de moins de 6 ans utiliser le lit supérieur.
7. Vérifiez et assurez-vous périodiquement que le garde-corps, l'échelle et les autres composants sont dans leur position correcte, exempts de dommages et que tous les connecteurs sont bien serrés.
8. Ne permettez pas les chahuts sur ou sous le lit et interdisez de sauter sur le lit.
9. Utilisez toujours l'échelle pour entrer et sortir du lit supérieur.
10. N'utilisez pas de pièce de rechange. Contactez le fabricant ou le revendeur pour une pièce de rechange
11. L'utilisation d'une veilleuse peut fournir une mesure de sécurité supplémentaire pour un enfant utilisant le lit supérieur.
12. Utilisez toujours des garde-corps sur les deux côtés longs du lit supérieur. Si le lit superposé doit être placé à côté du mur, le garde-corps qui s'étend sur toute la longueur du lit doit être placé contre le mur pour éviter tout coincement entre le lit et le mur.
13. L'utilisation de matelas flottants à eau ou de sommeil est interdite
14. **RISQUE D'ÉTRANGULATION** - N'attachez ou ne suspendez jamais d'objets à une partie du lit superposé qui ne sont pas conçus pour être utilisés avec le lit ; par exemple, mais sans s'y limiter, des crochets, des ceintures et des cordes à sauter
15. Conservez ces instructions pour référence future
16. Interdire plus d'une personne sur la couchette supérieure
17. Nous vous recommandons d'assembler votre lit superposé sur le carton d'expédition pour protéger votre sol ou votre tapis.
18. Assurez-vous que toutes les agrafes sont sorties de la boîte avant de commencer l'assemblage sur le carton d'expédition.

ASSEMBLY INSTRUCTION

INSTRUCTIONS DEMONTAGE

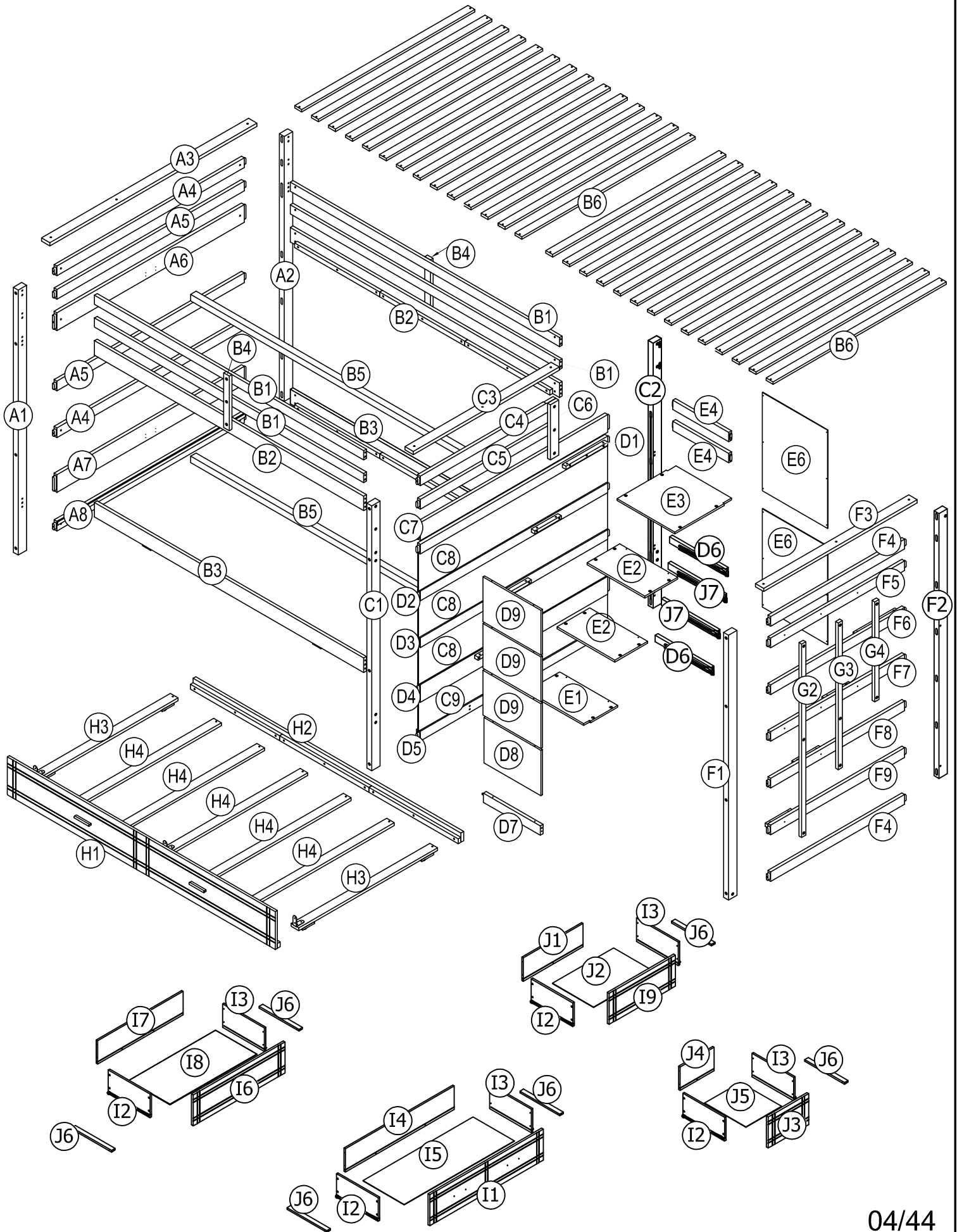

Part List (Box1)

Liste des pièces

B4



WoodBar-2pcS
Barres de bois

J5

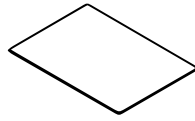

Panel-1pc
Planche

D7

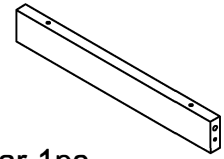

WoodBar-1pc
Barres de bois

D8

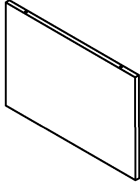

Panel-1pc
Planche

D9

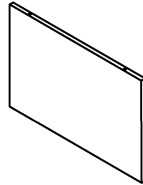

Panel-3pcs
Planche

E1

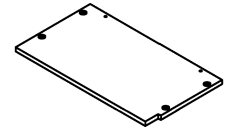

Panel-1pc
Planche

E2

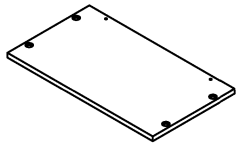

Panel-2pcs
Planche

E3

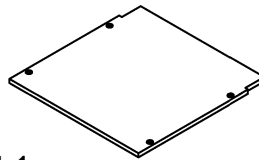

Panel-1pc
Planche

E4



WoodBar-2pcs
Barres de bois

J2

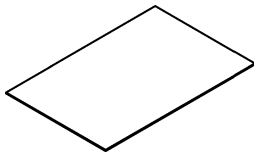

Panel-1pc
Planche

C3

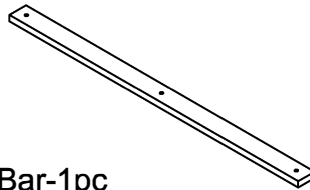

WoodBar-1pc
Barres de bois

C4

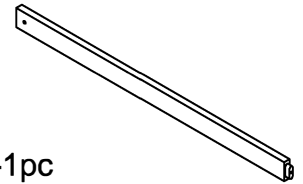

WoodBar-1pc
Barres de bois

C5

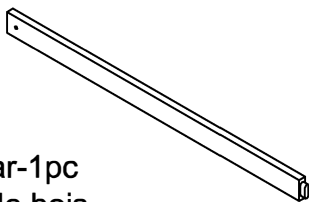

WoodBar-1pc
Barres de bois

C6



WoodBar-1pc
Barres de bois

C8

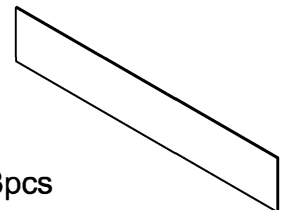

Panel-3pcs
Planche

C9

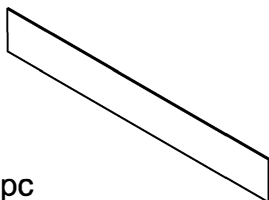

Panel-1pc
Planche

F3

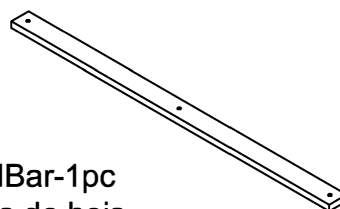

WoodBar-1pc
Barres de bois

F4

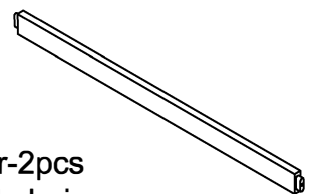

WoodBar-2pcs
Barres de bois

F5

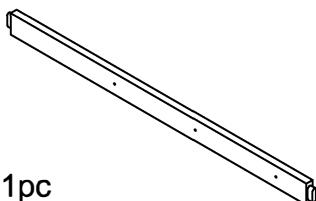

WoodBar-1pc
Barres de bois

F6

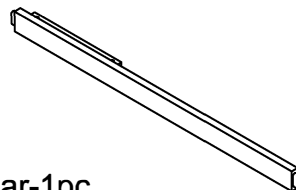

WoodBar-1pc
Barres de bois

F7

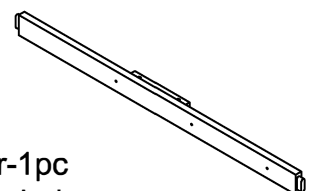

WoodBar-1pc
Barres de bois

Part List (Box1)

Liste des pièces

F8

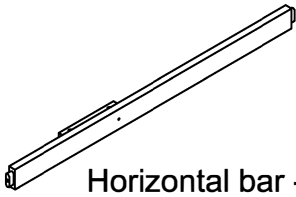

Horizontal bar - 1PC
Barre horizontale

F9

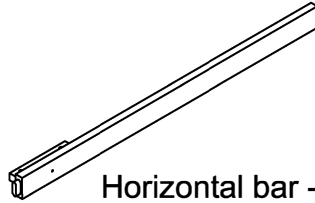

Horizontal bar - 1PC
Barre horizontale

B6

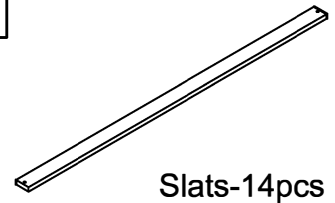

Slats-14pcs
Lattes

I1

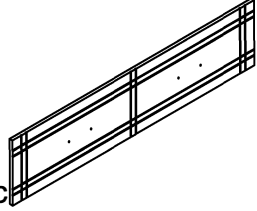

Panel-1pc
Planche

I6

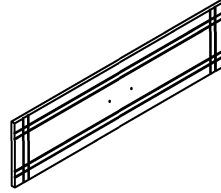

Panel-1pc
Planche

I5

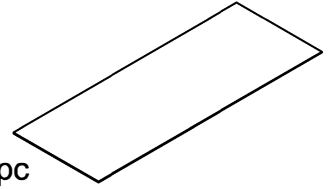

Panel-1pc
Planche

I8

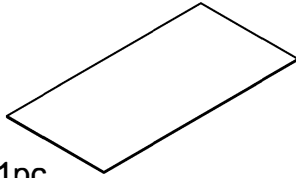

Panel-1pc
Planche

I9

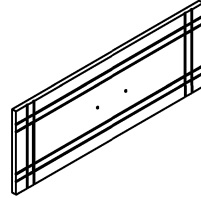

Panel-1pc
Planche



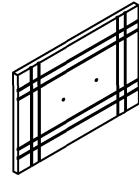



J3

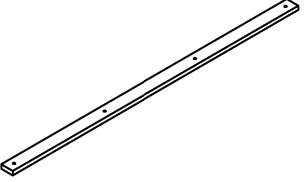

Panel-1pc
Planche

Part List & Hardware List (Box2)

Liste des pièces et liste du matériel

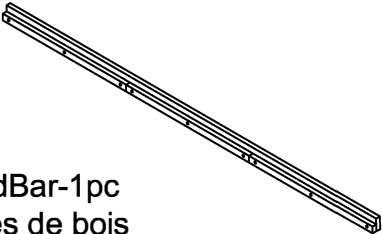
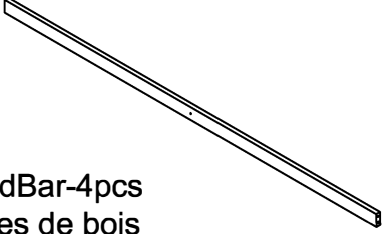
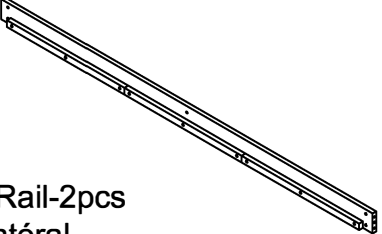
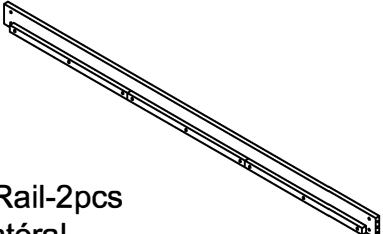
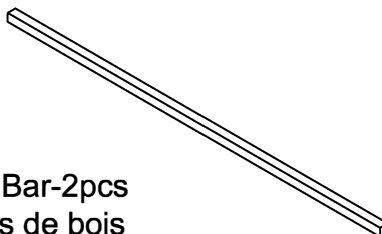
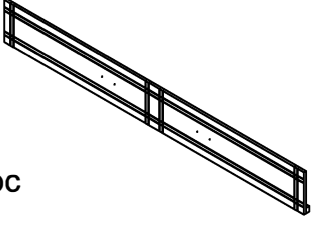
A1  Leg-1pc Jambe	A2  Leg-1pc Jambe	A3  Leg-1pc Jambe
F1  Leg-1pc Jambe	F2  Leg-1pc Jambe	C1  Leg-1pc Jambe
C2  Leg-1pc Jambe	H2  WoodBar-1pc Barres de bois	B1  WoodBar-4pcs Barres de bois
B2  Side Rail-2pcs Rail latéral	B3  Side Rail-2pcs Rail latéral	B5  WoodBar-2pcs Barres de bois
H1  Panel-1pc Planche		

Part List (Box3)

Liste des pièces

B6

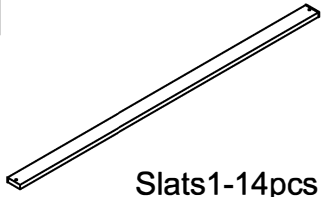

Slats1-14pcs
Lattes

J1

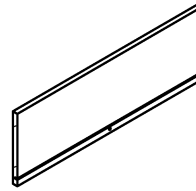

Panel-1pc
Planche

J4

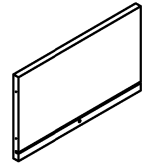

Panel-1pc
Planche

A4

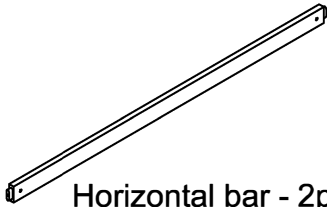

Horizontal bar - 2pcs
Barre horizontale

A5

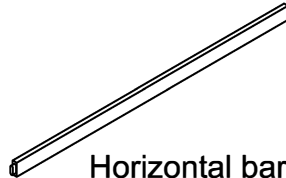

Horizontal bar - 2pcs
Barre horizontale

A6

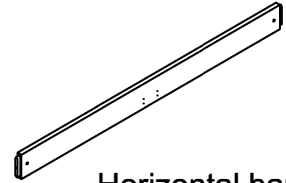

Horizontal bar - 1PC
Barre horizontale

A7

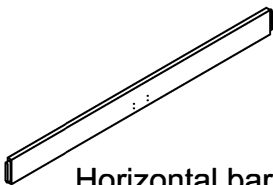

Horizontal bar - 1PC
Barre horizontale

A8

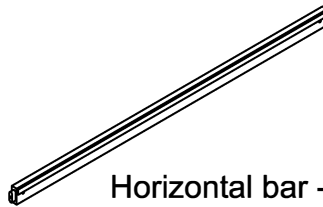

Horizontal bar - 1PC
Barre horizontale

G3



WoodBar-1pc
Barres de bois

G4



WoodBar-1pc
Barres de bois

H3

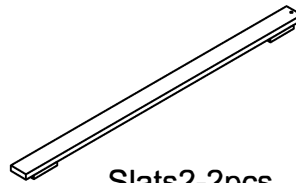

Slats2-2pcs
Lattes

H4

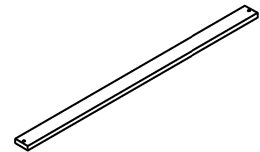

Slats2-5pcs
Lattes

I2

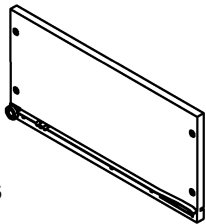

Panel-4pcs
Planche

I3

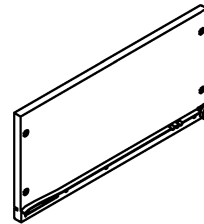

Panel-4pcs
Planche

C7

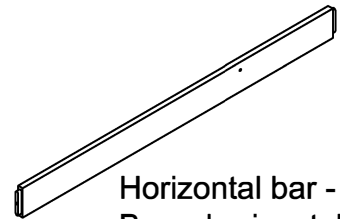

Horizontal bar - 1PC
Barre horizontale

I4

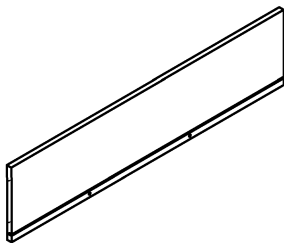

Panel-1pc
Planche

I7

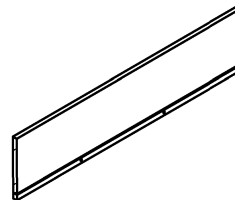

Panel-1pc
Planche

D1

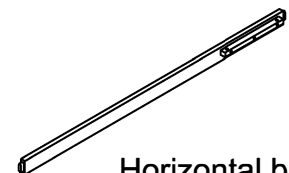

Horizontal bar - 1PC
Barre horizontale

D2

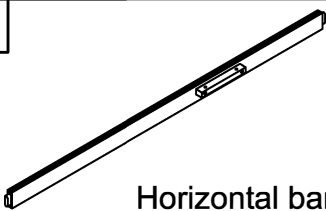

Horizontal bar - 1PC
Barre horizontale

D3

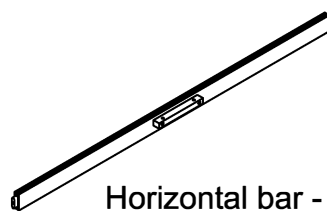

Horizontal bar - 1PC
Barre horizontale

D4

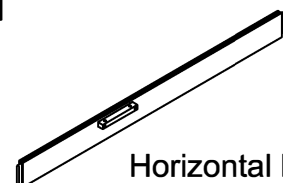

Horizontal bar - 1PC
Barre horizontale

Part List (Box3)

Liste des pièces

D5

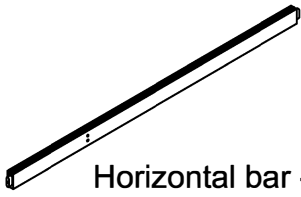

Horizontal bar - 1PC
Barre horizontale

G2



WoodBar-1pc
Barres de bois

E6

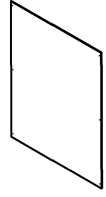

Panel-2pcs
Planche

D6

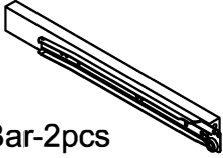

WoodBar-2pcs
Barres de bois

J7

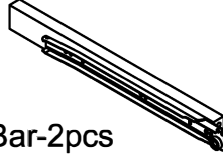

WoodBar-2pcs
Barres de bois



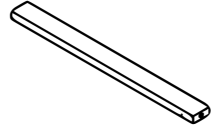







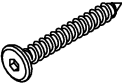
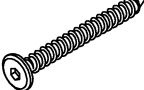
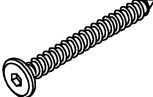

J6

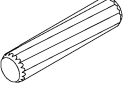
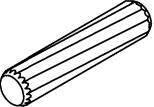

WoodBar-6pcs
Barres de bois

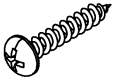
Hardware List (Box2)

Liste du matériel

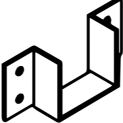
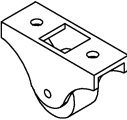
<p>1</p>  <p>Screws 1/4" x30mm- 14pcs Vis</p>	<p>2</p>  <p>Screws 1/4" x50mm- 3pcs Vis</p>	<p>3</p>  <p>Screws 1/4" x60mm- 5pcs Vis</p>
<p>4</p>  <p>Bolts Ø1/4" x 25 mm - 19pcs Boulon</p>	<p>5</p>  <p>Bolts Ø1/4" x 80 mm - 24pcs Boulon</p>	<p>6</p>  <p>Bolts Ø1/4" x 100 mm - 23pcs Boulon</p>
<p>7</p>  <p>Ø1/4" x 13 mm Horizontal-Hole bolts - 47pcs Boulons à trou horizontal</p>	<p>8</p>  <p>Wood dowel Ø6 x 30 mm - 22pcs Cheville en bois</p>	<p>9</p>  <p>Wood dowel Ø8 x 30 mm - 14pcs Cheville en bois</p>
<p>10</p>  <p>Wood dowel Ø10 x 40 mm -16pcs Cheville en bois</p>	<p>11</p>  <p>Wood Screws M4 x 20mm- 16pcs Les vis à bois</p>	<p>12</p>  <p>Wood Screws M4 x 30mm-123pcs Les vis à bois</p>
<p>13</p>  <p>Wood Screws M4 x 15mm- 32pcs Les vis à bois</p>	<p>14</p>  <p>Wood Screws M3 x12mm-12pcs Les vis à bois</p>	<p>15</p>  <p>Bolts Ø1/6" x 15 mm - 14pcs Boulon</p>
<p>16</p>  <p>Ø1/4" x 15 mm Canopy head though - 3pcs Tête à baldaquin</p>	<p>17</p>  <p>Steel Bracket - 4pcs Support en acier</p>	<p>18</p>  <p>Wheels - 4pcs Roues</p>

Hardware List (Box2)

Liste du matériel

19

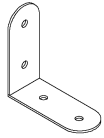

Metal L patt -3pcs
quille d'angle en fer

20

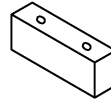

WoodBar-2pcs
Barres de bois

21



Allen Key - 1pc
Clé Allen

22



Steel Bracket - 6pcs
Support en acier

23

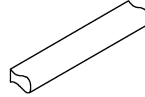



Handle 7pcs
Poignée



Assembly Tools Required (Not Included)
Outils d'assemblage requis (Non Inclus)

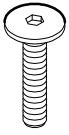

STEP 1:

Étape 1:

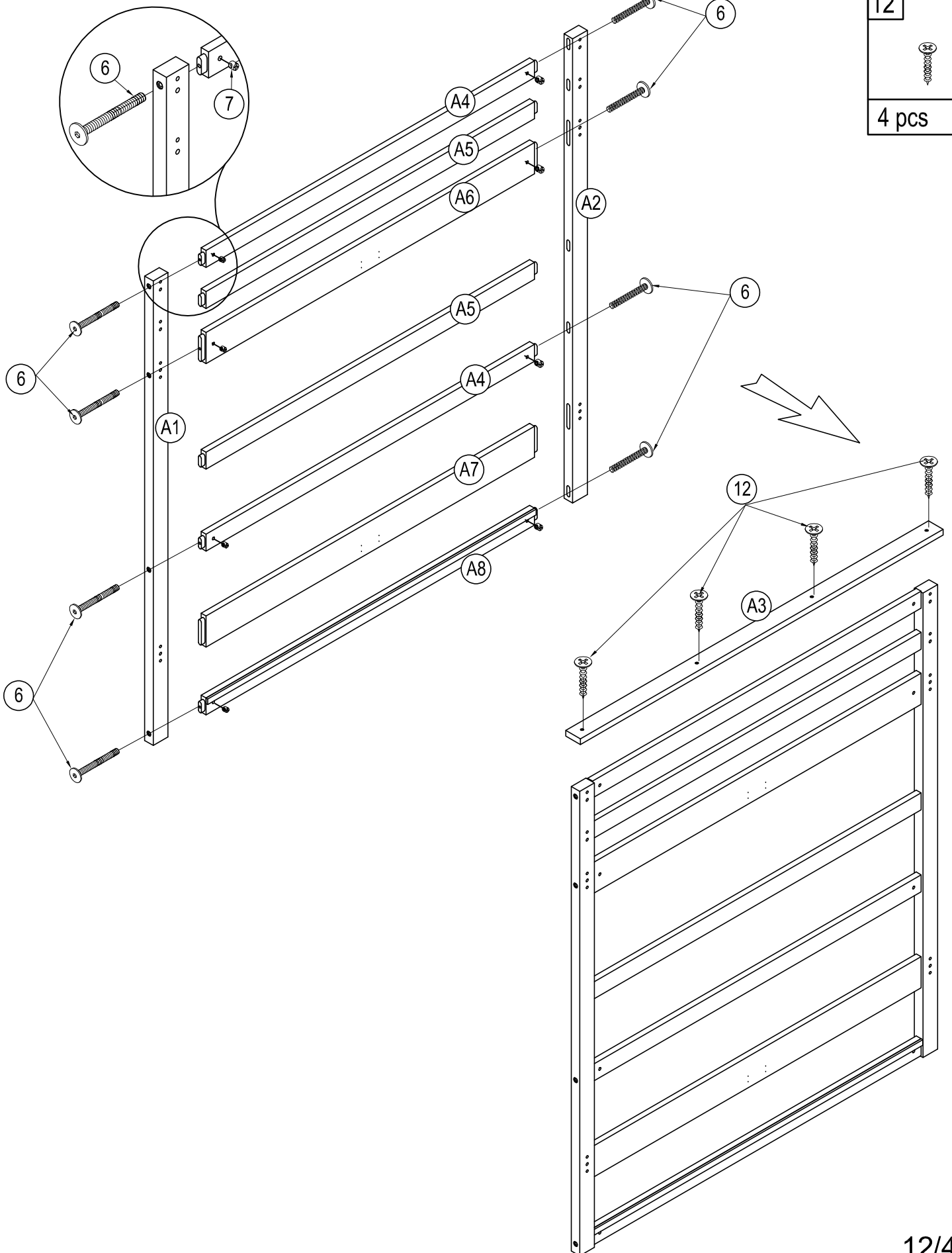
6		7	
8 pcs		8 pcs	
		12	
		4 pcs	



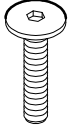

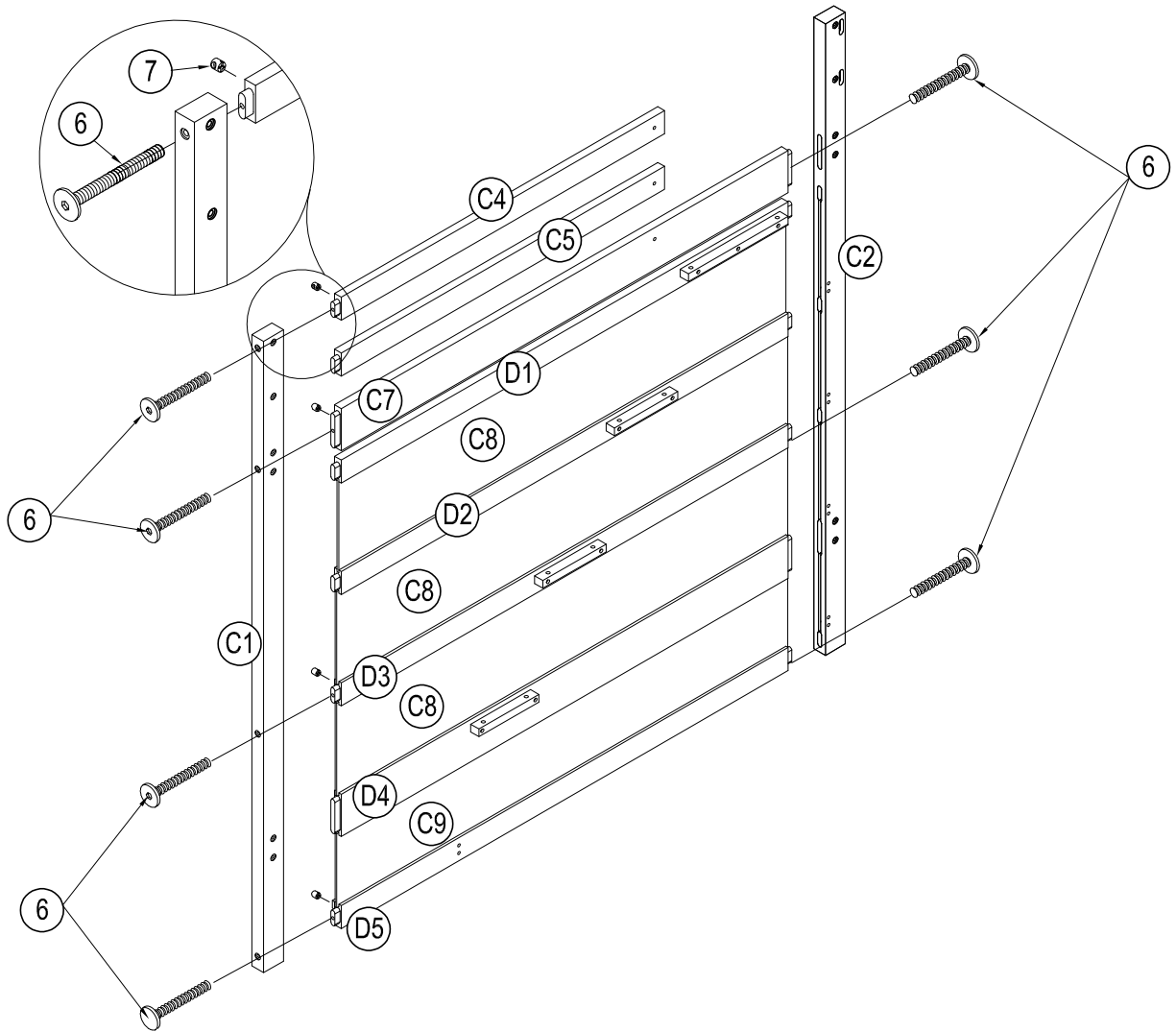

STEP 2:
Étape 2:

6		7	
7 pcs		7 pcs	

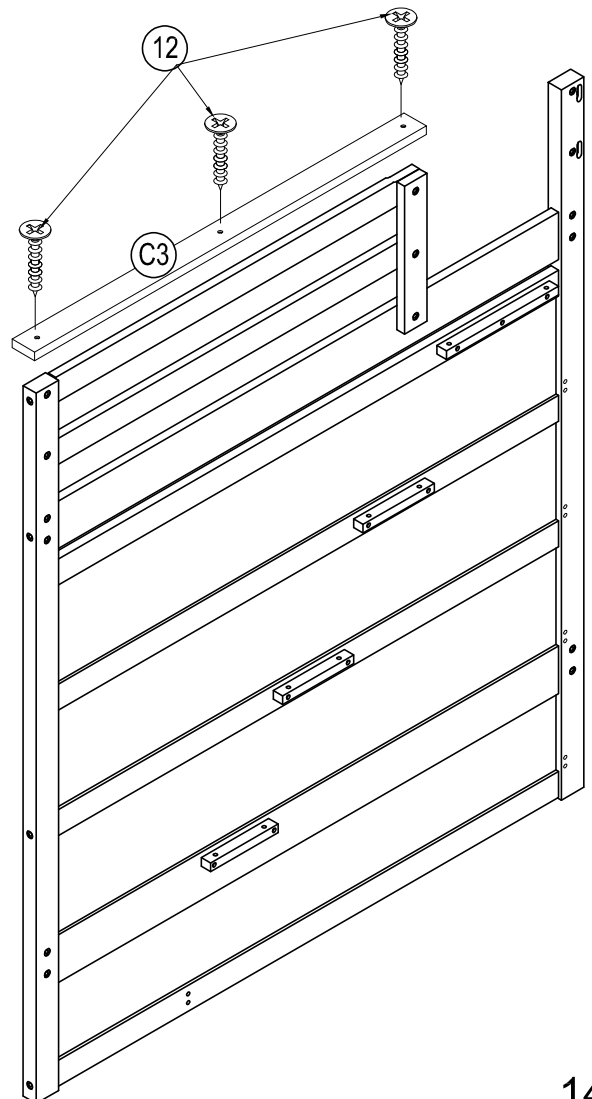
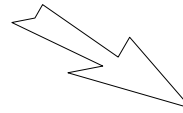
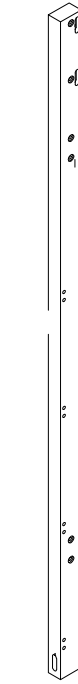
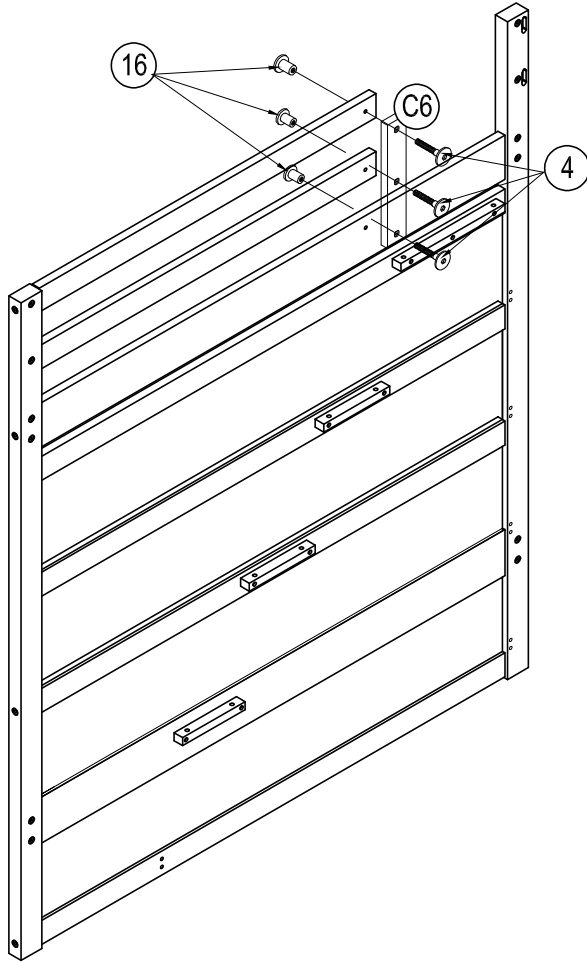

STEP 3:
Étape 3:

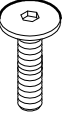

12	4
	
3 pcs	3 pcs
	16
	
	3 pcs

STEP 4:

Étape 4:

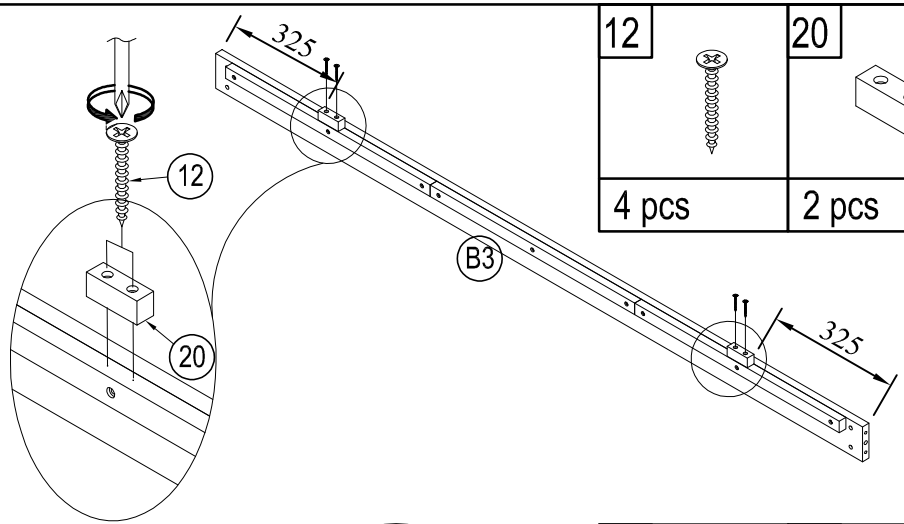

12		20	
4 pcs		2 pcs	

STEP 5:

Étape 5:

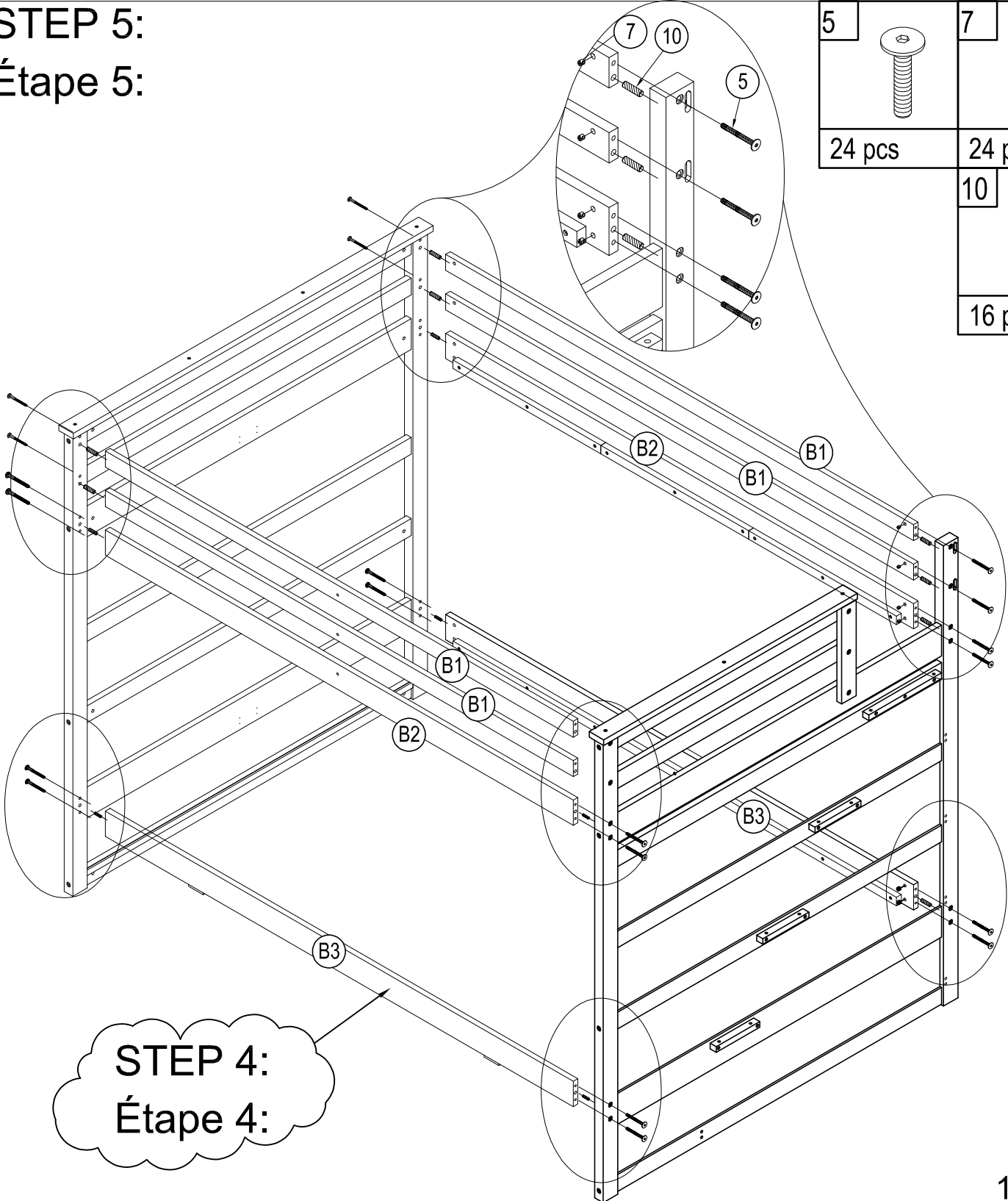

5		7	
24 pcs		24 pcs	
		10	
16 pcs			

STEP 4:
Étape 4:

STEP 6:

Étape 6:

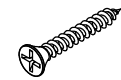
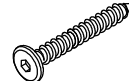
17	11
	
4(pcs)	16(pcs)
	1
	
	6(pcs)

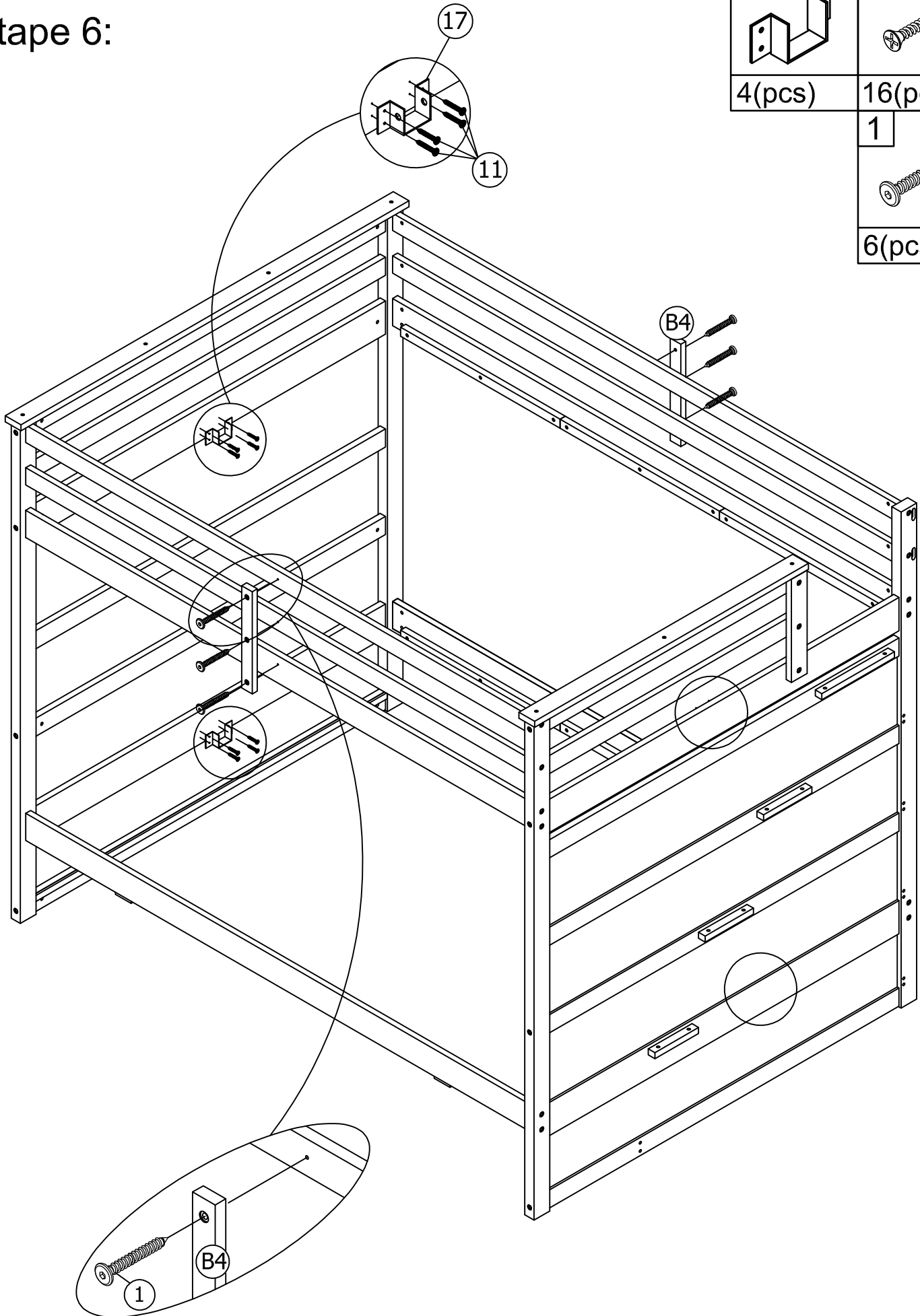

STEP 7:

Étape 7:

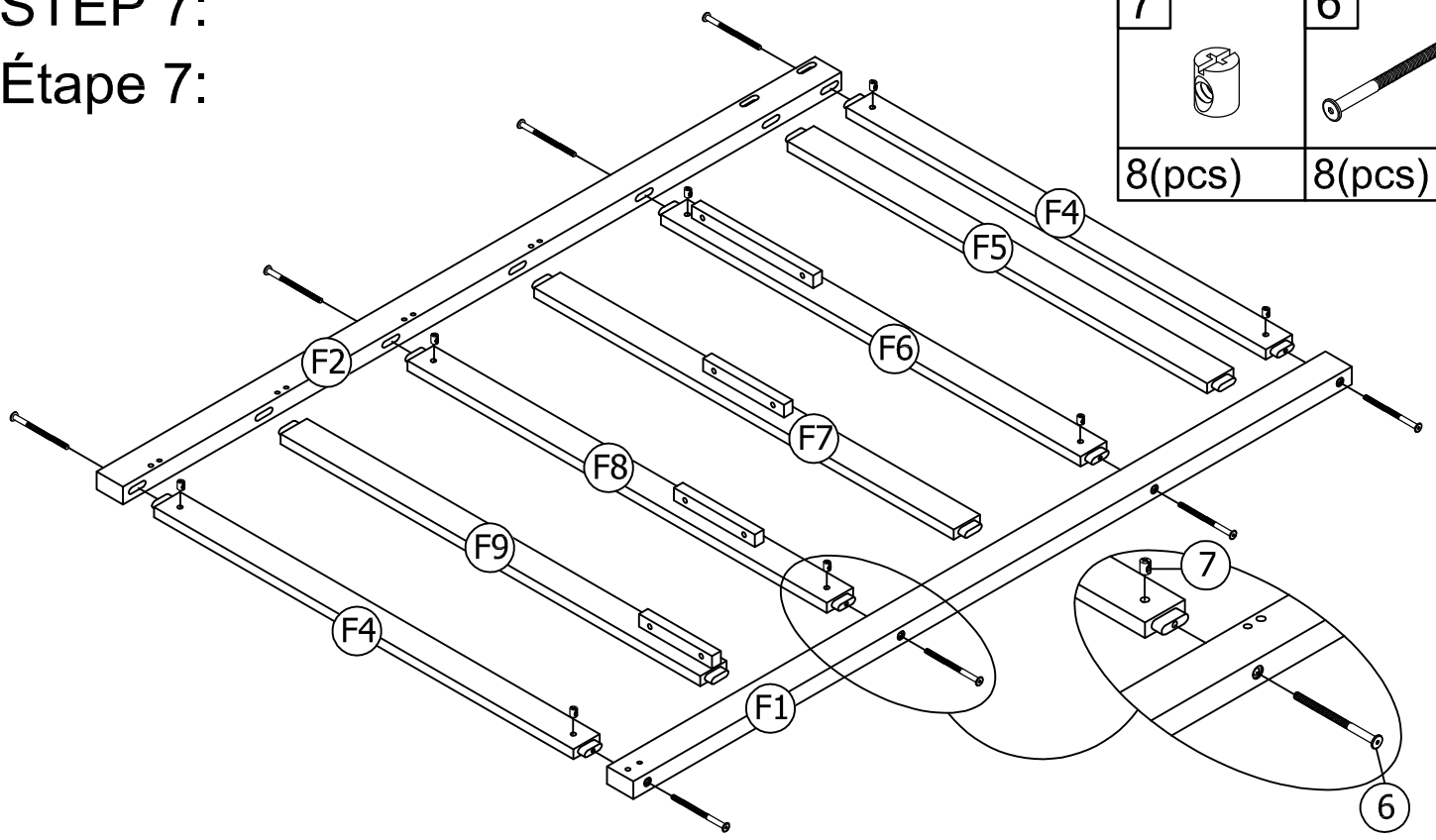

STEP 8:

Étape 8:

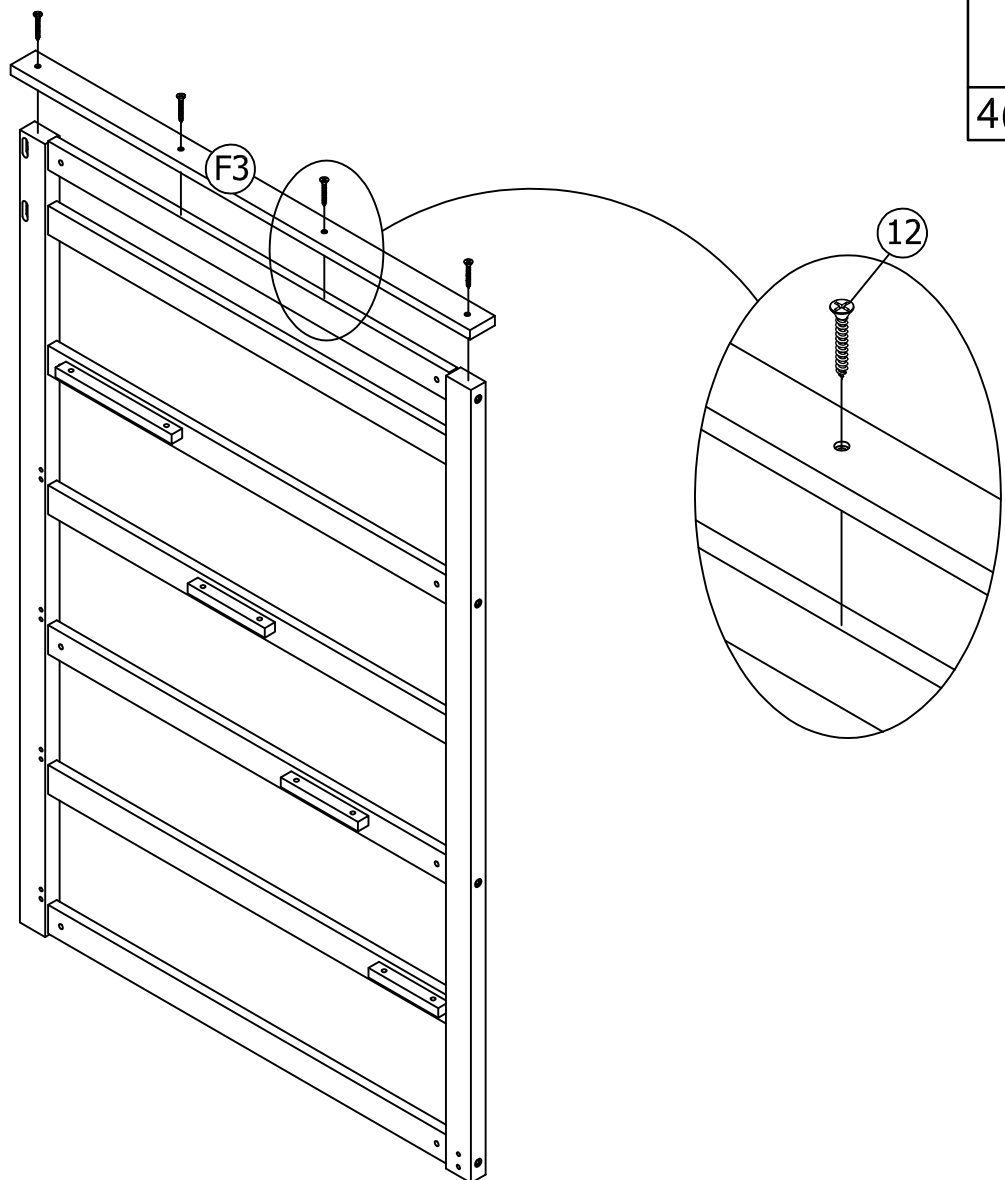

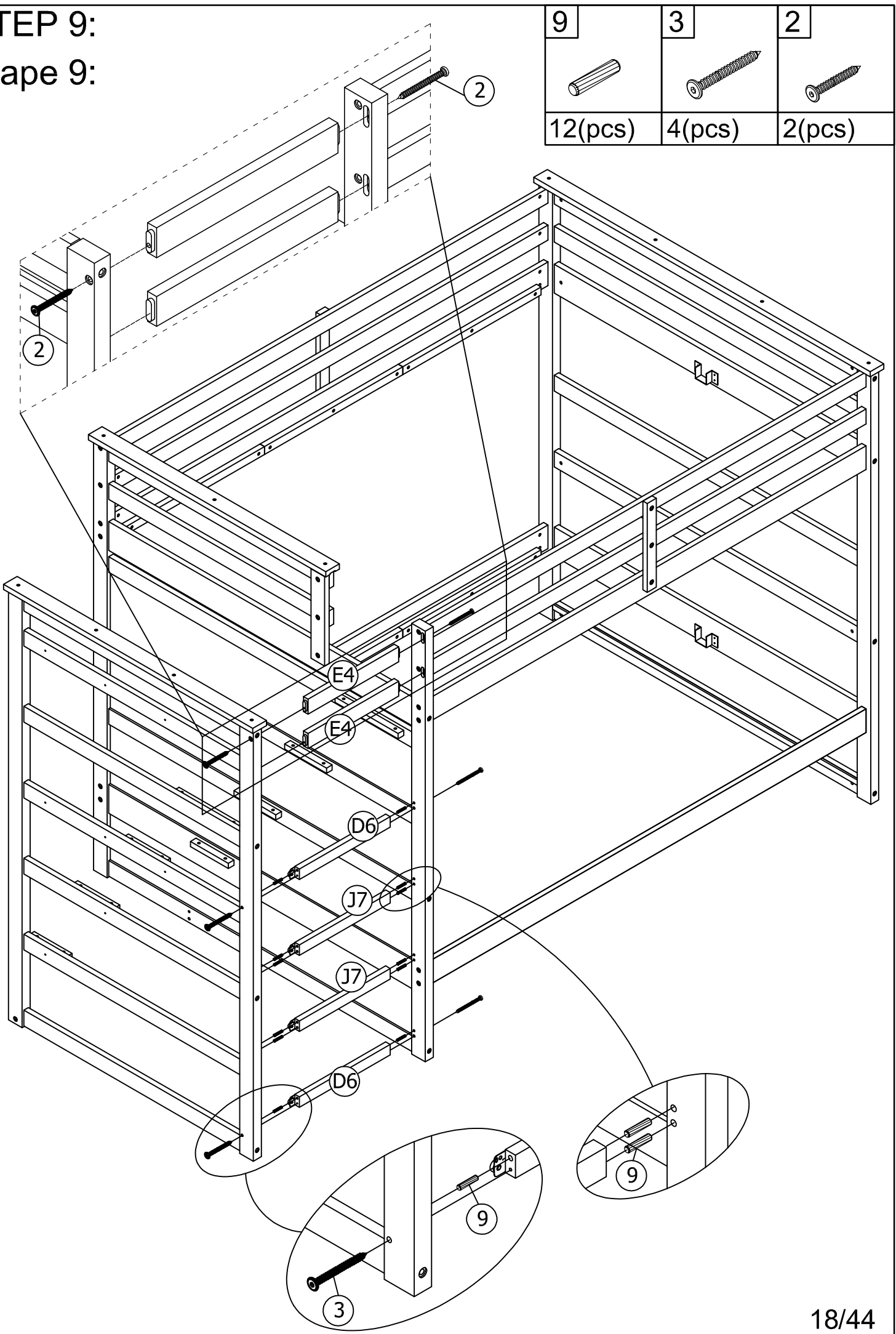

STEP 9:

Étape 9:



STEP 10:

Étape 10:

9	3	2
		
2(pcs)	1(pc)	1(pc)

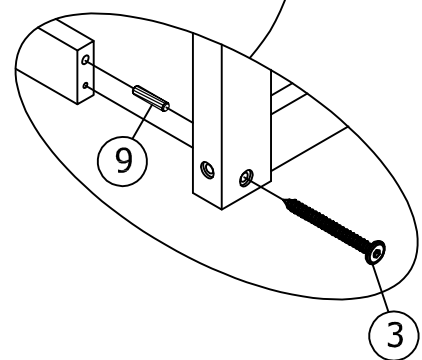
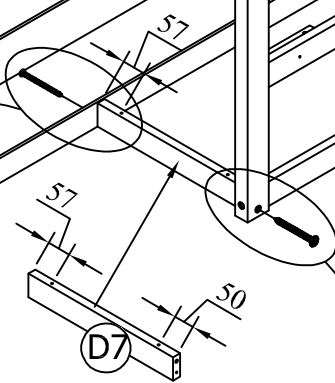
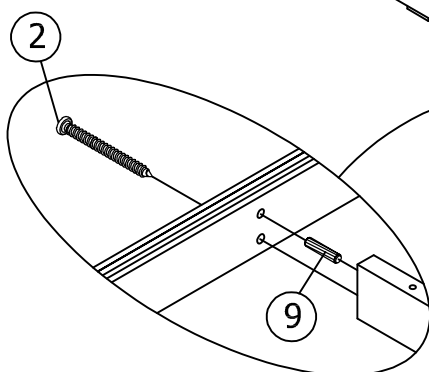
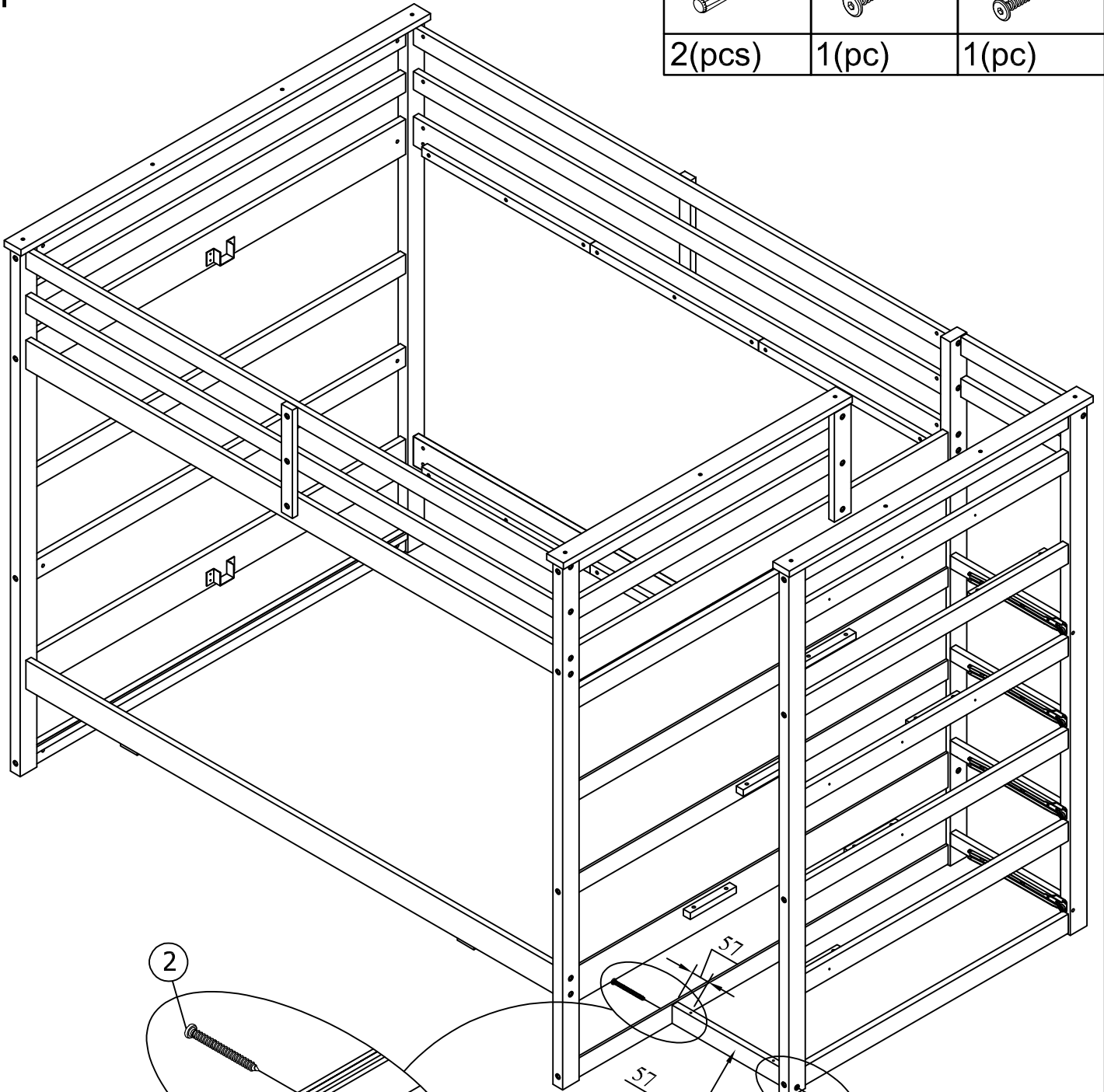

STEP 11:

Étape 11:

8



2(pcs)

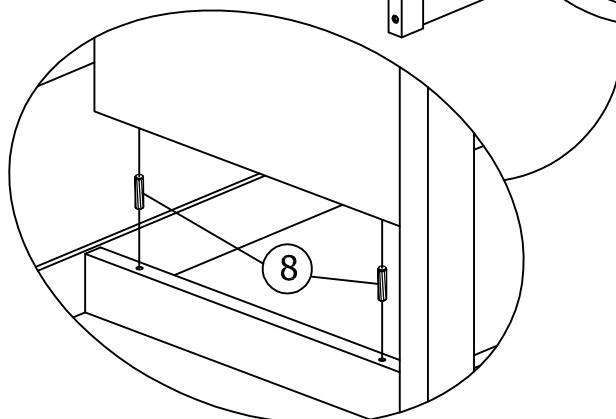
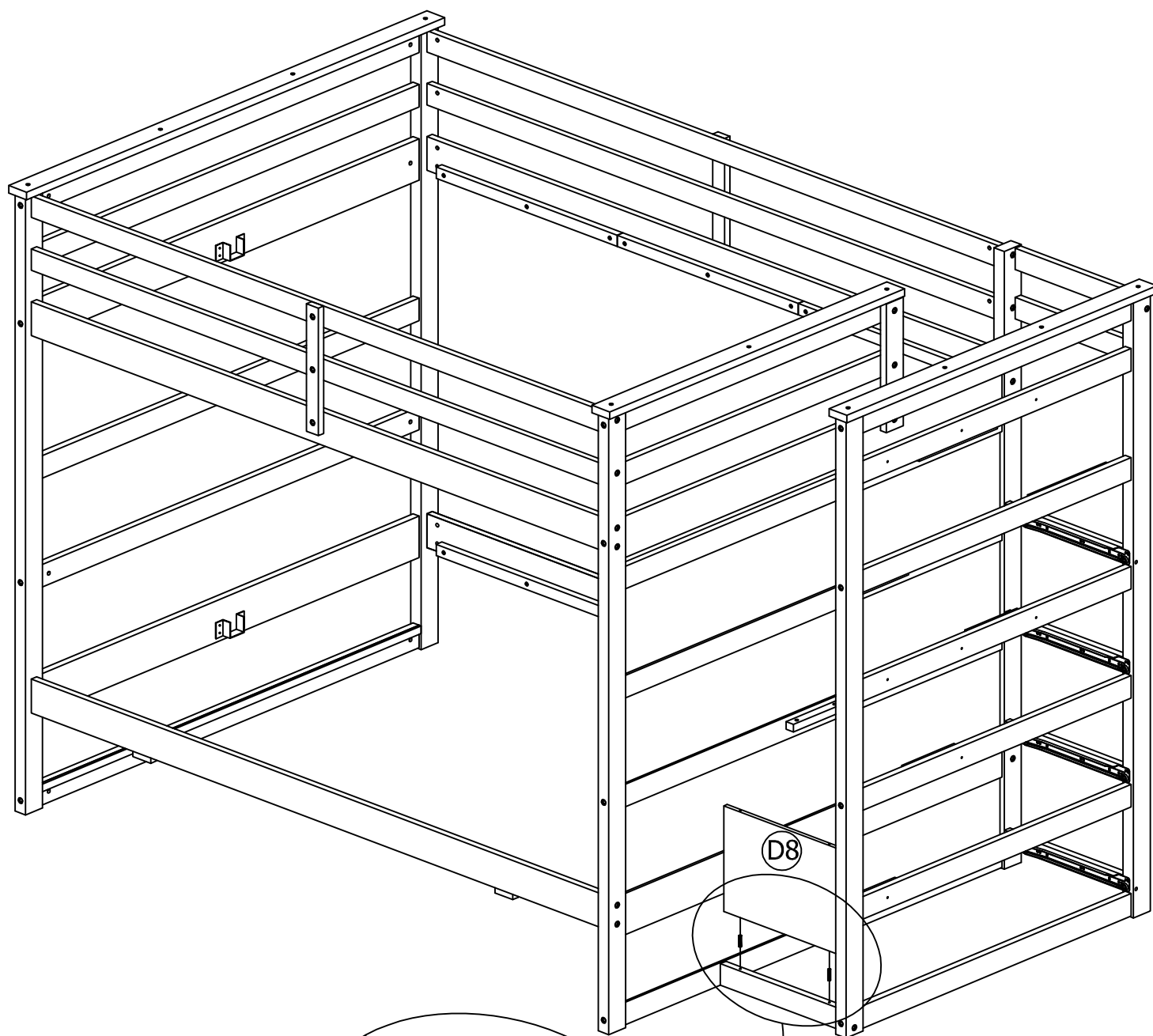

STEP 12:

Étape 12:

8

4

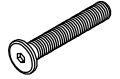

2(pcs)

4(pcs)

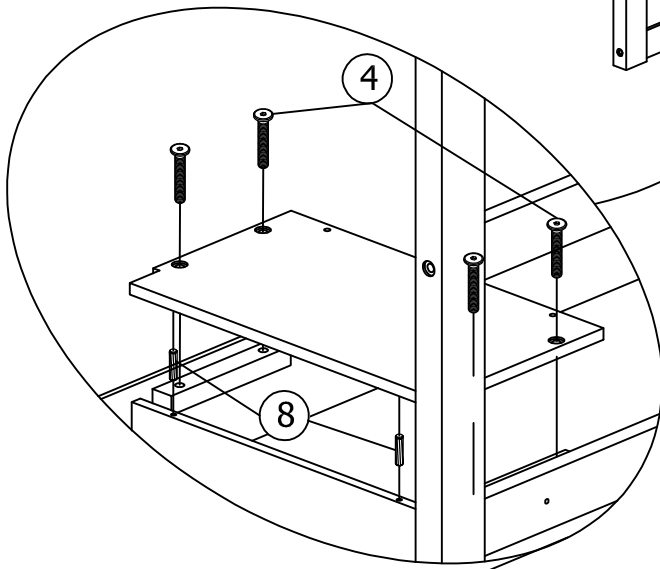
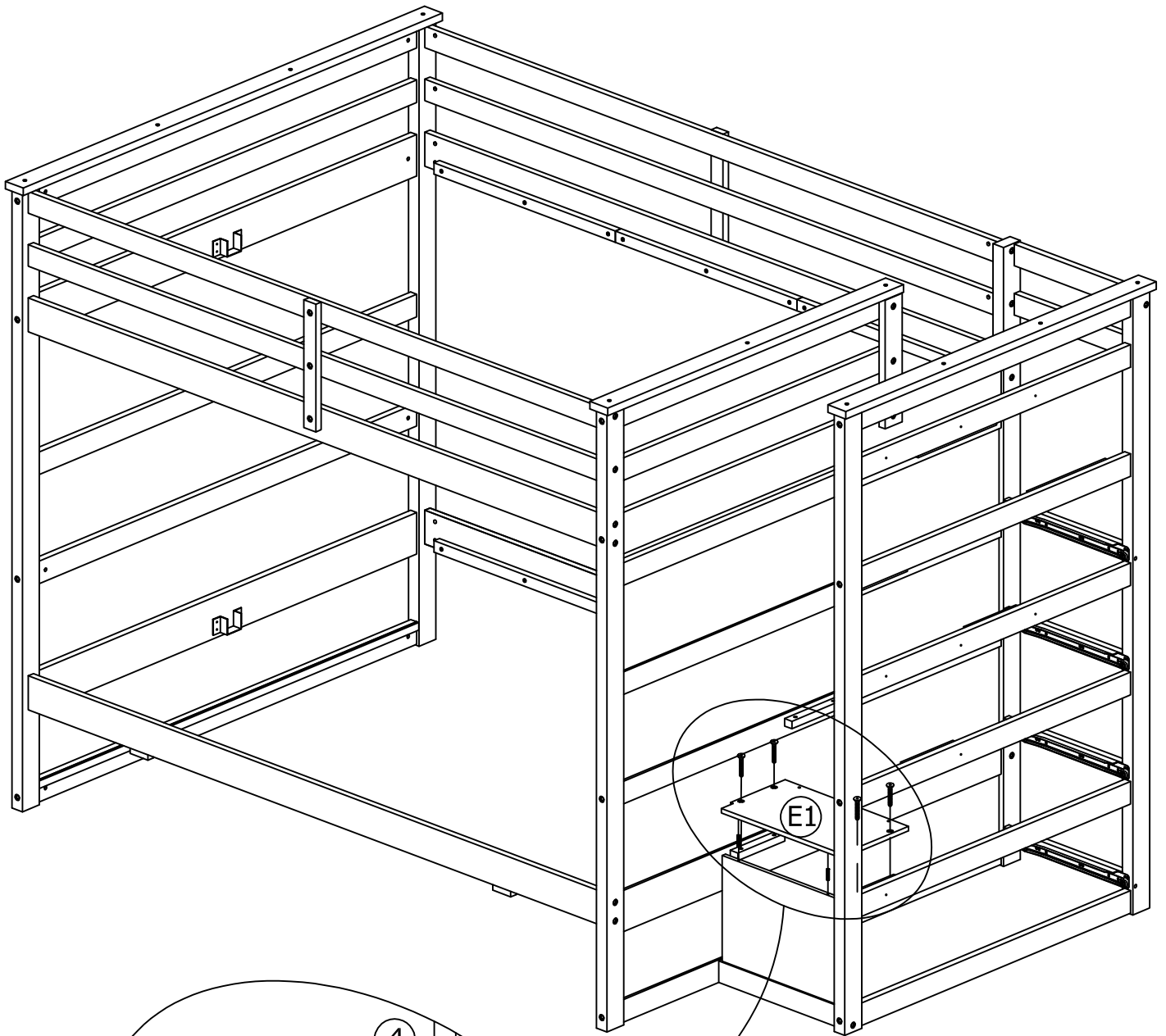

STEP 13:

Étape 13:

8

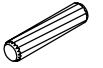

2(pcs)

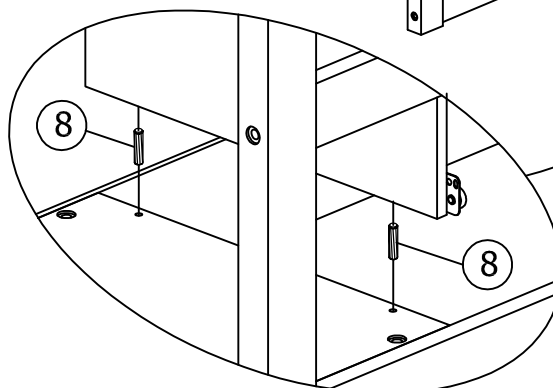
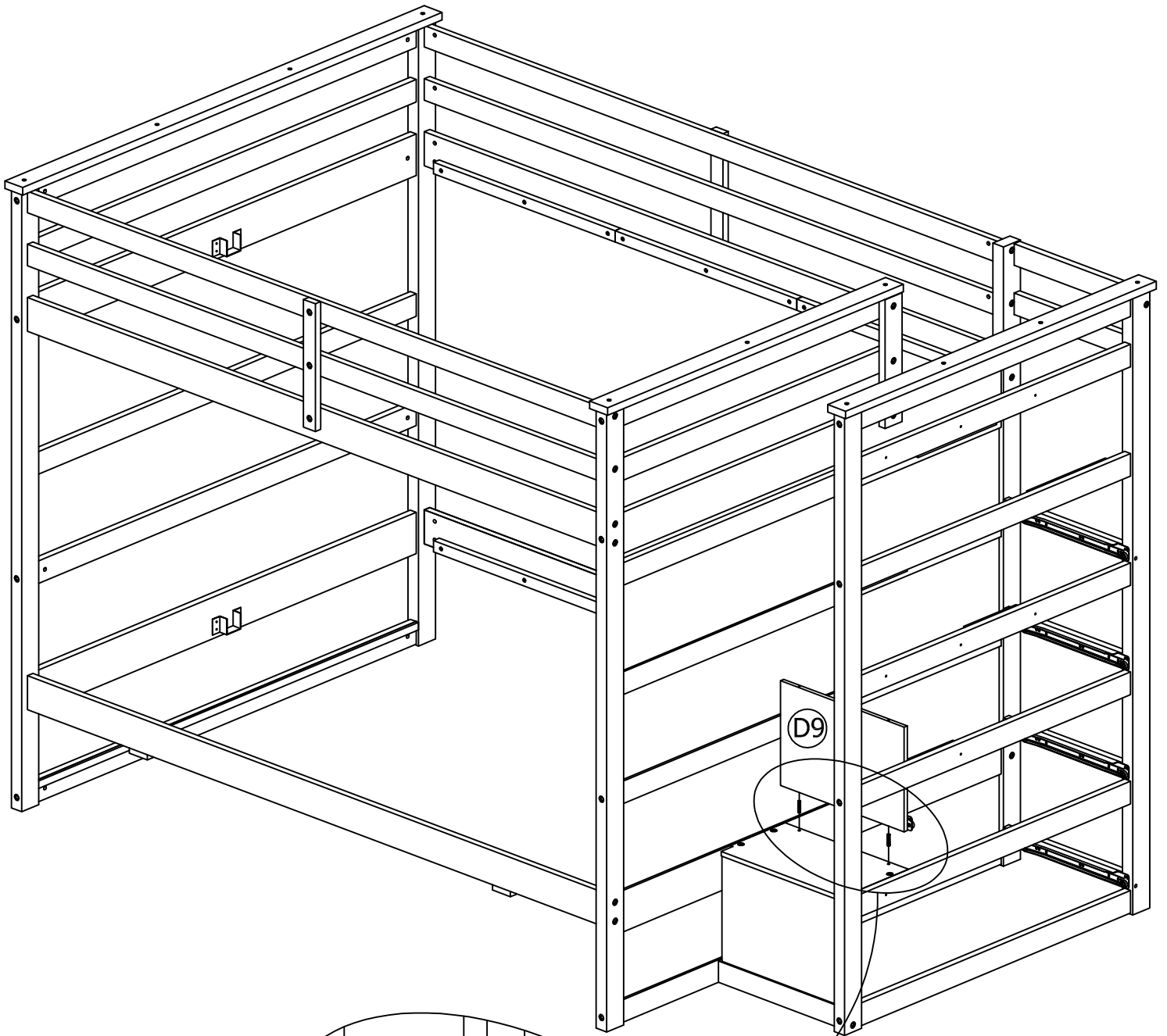

STEP 14:

Étape 14:

8

4

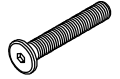

2(pcs)

4(pcs)

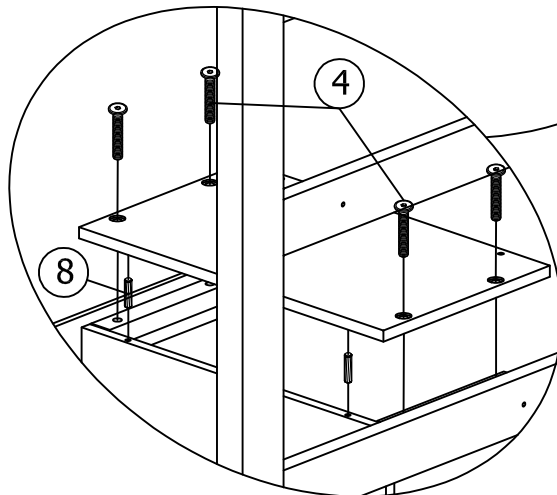
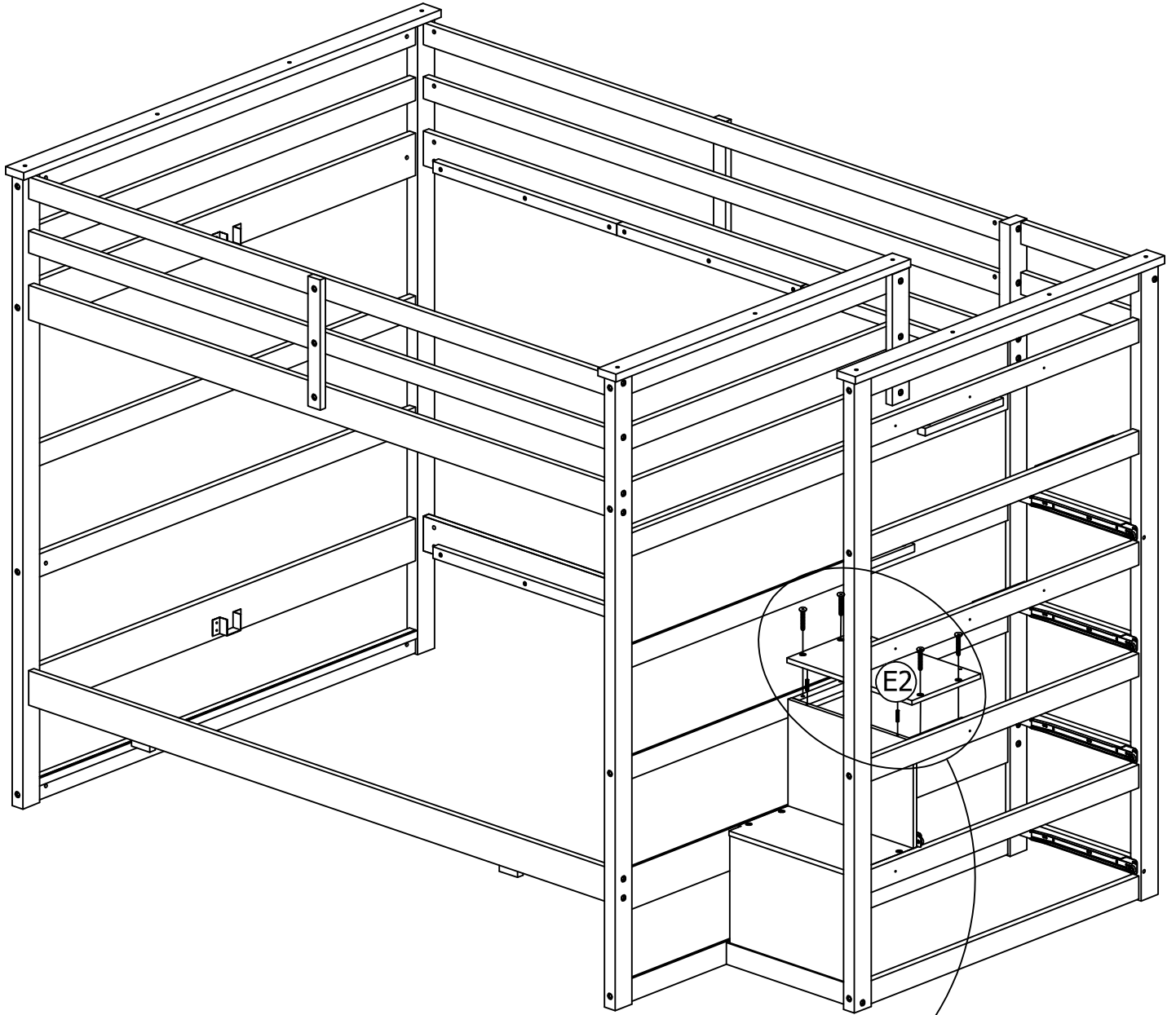

STEP 15:

Étape 15:

8



2(pcs)

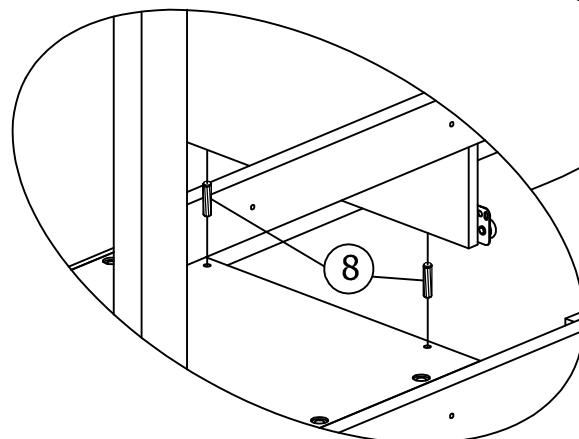
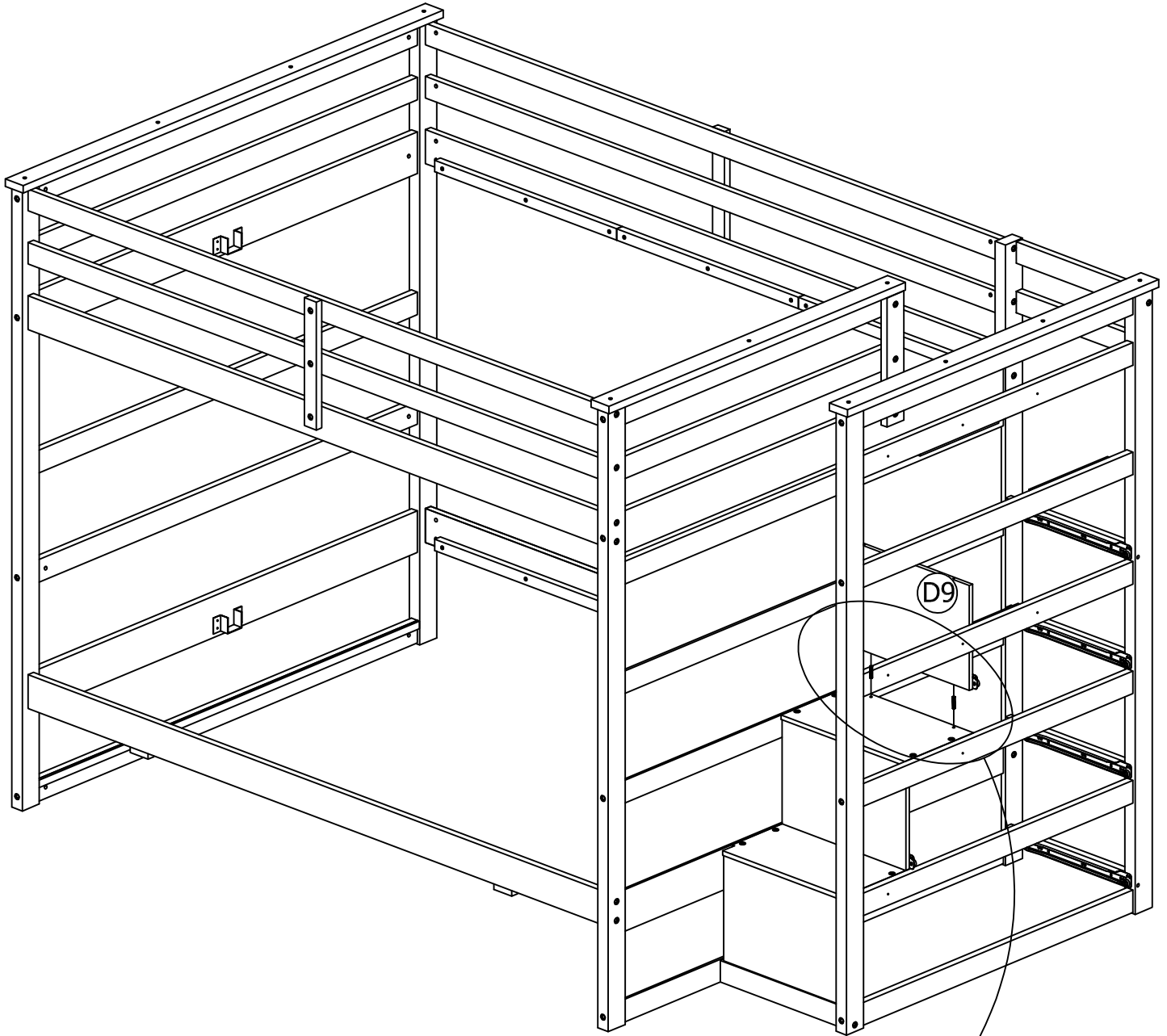

STEP 16:

Étape 16:

8

4

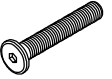

2(pcs)

4(pcs)

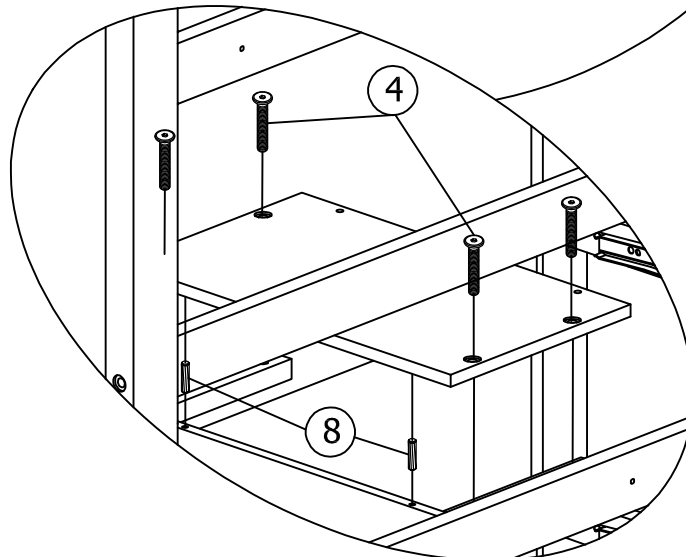
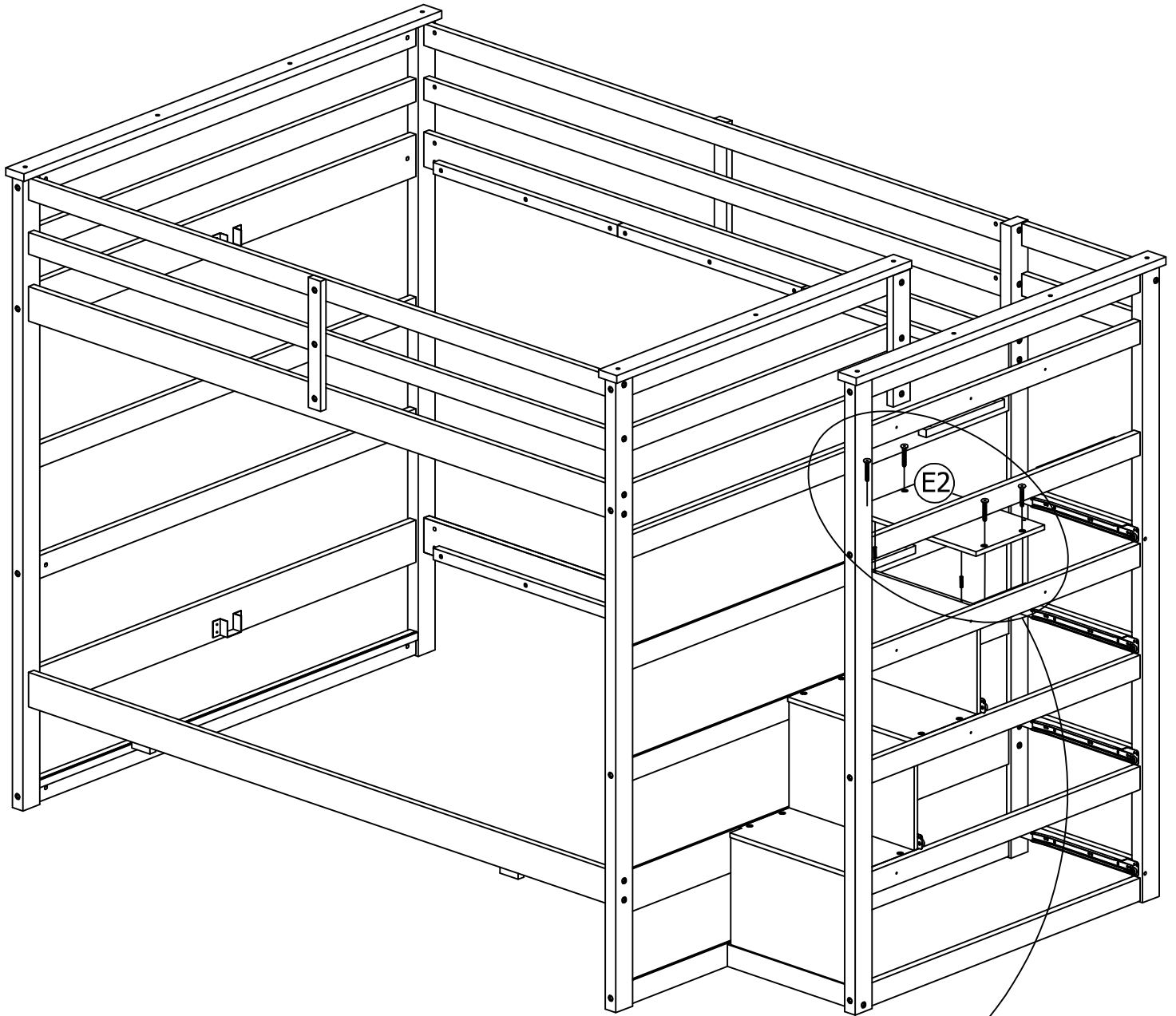

STEP 17:

Étape 17:

8



2(pcs)

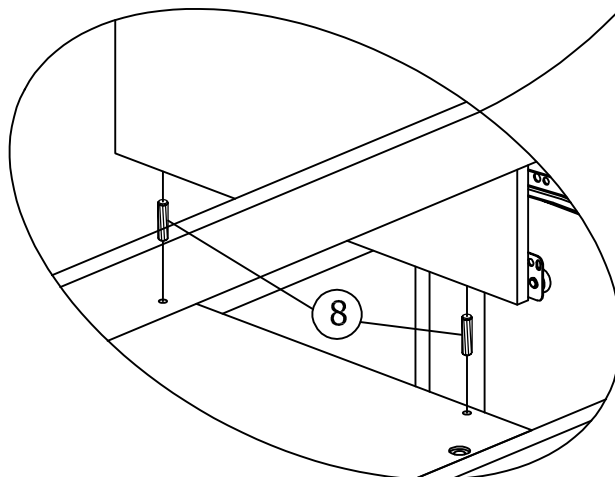
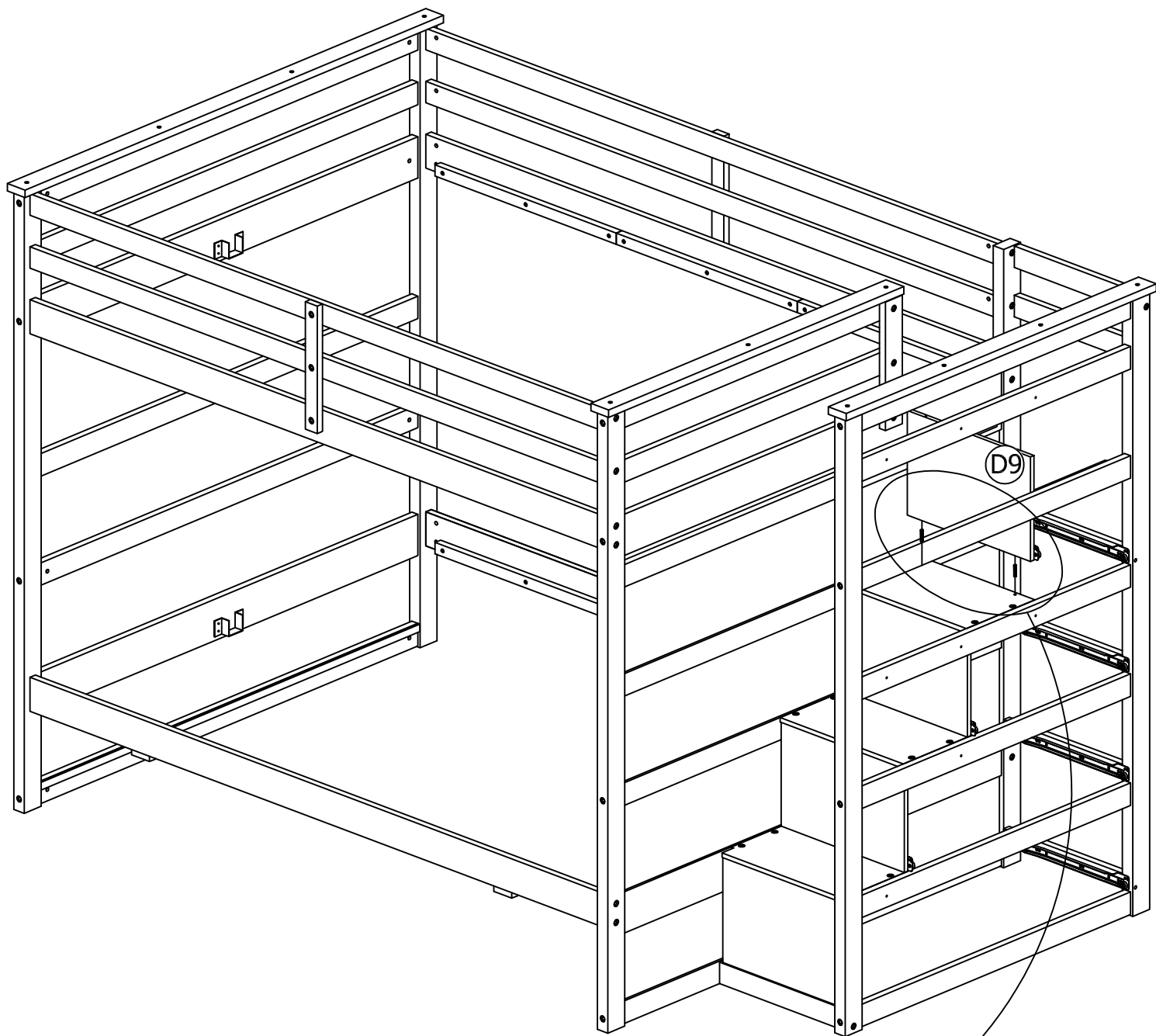

STEP 18:

Étape 18:

8

4

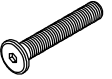

2(pcs)

4(pcs)

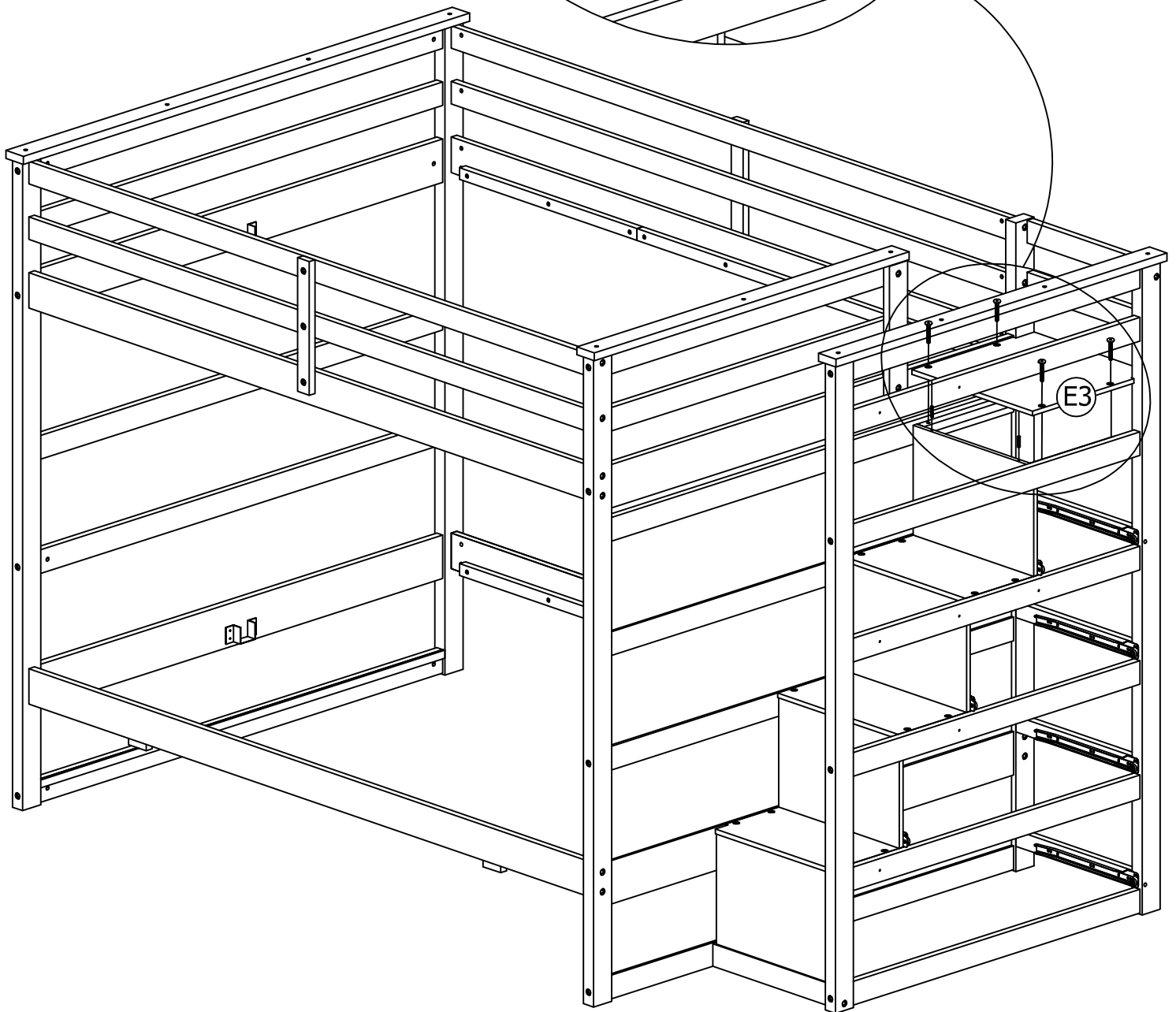
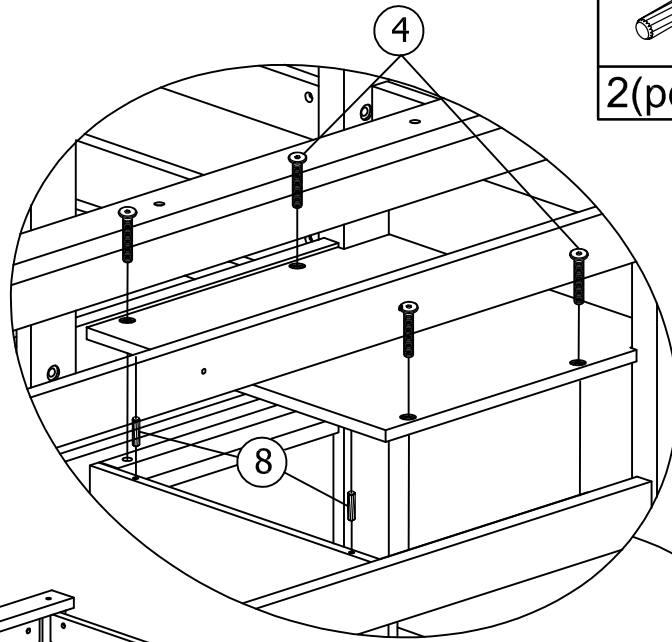

STEP 19:

Étape 19:

1

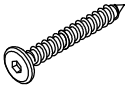

8(pcs)

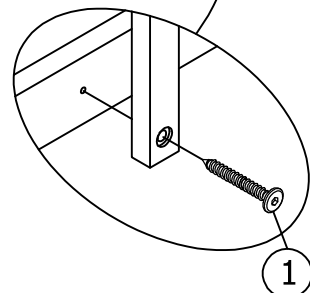
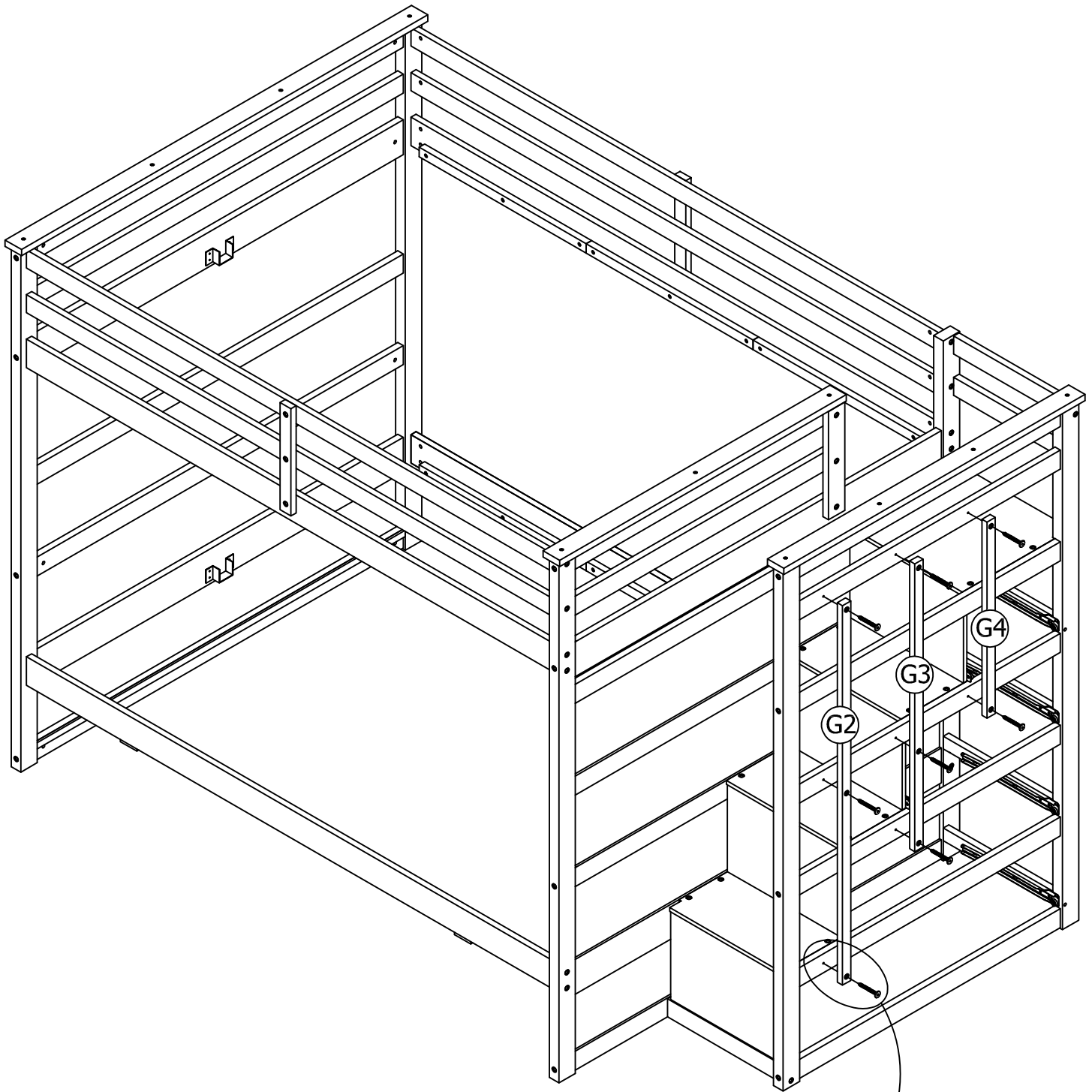

STEP 20:

Étape 20:

13

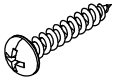

12(pcs)

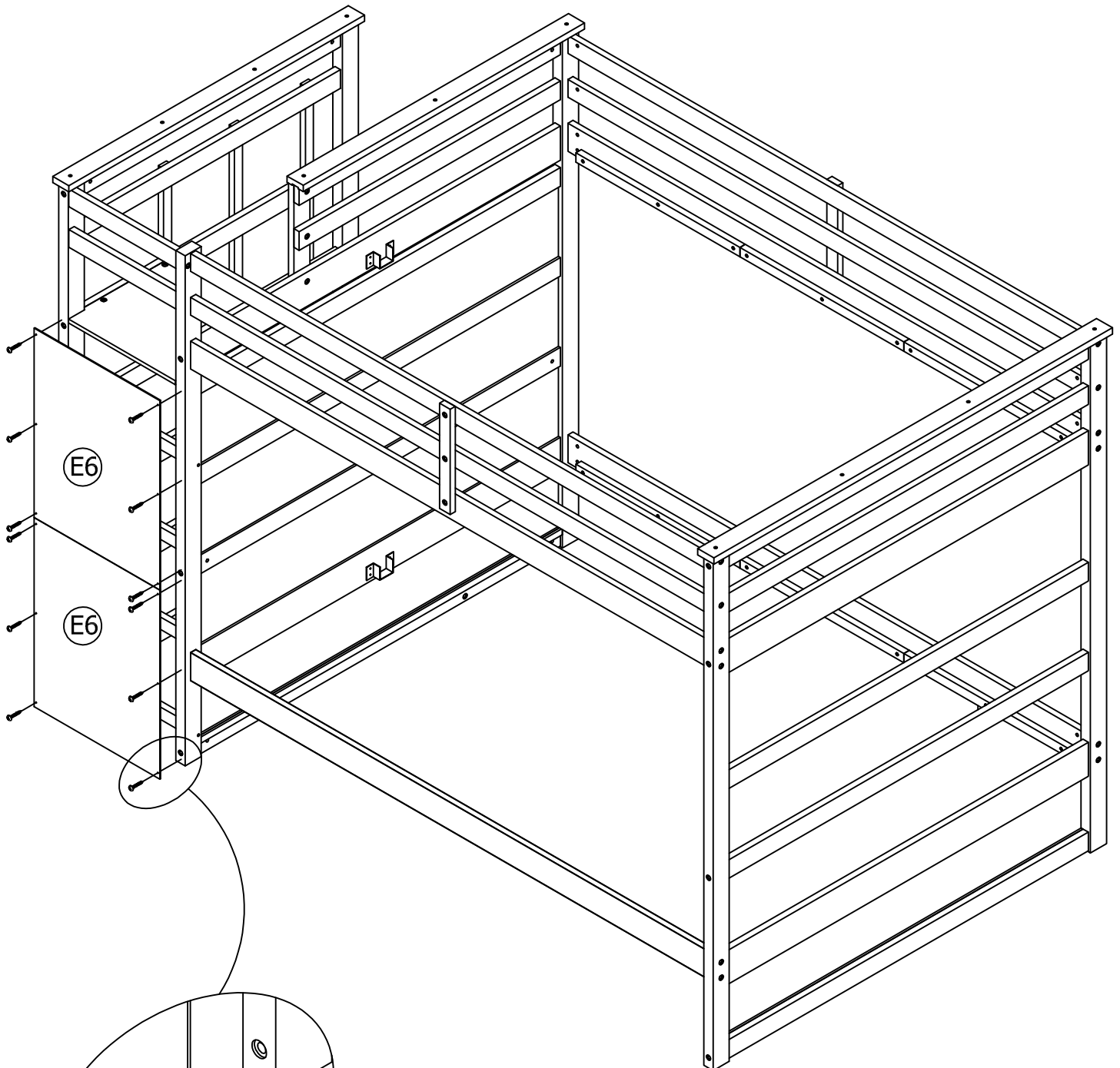

13

STEP 21:

Étape 21:

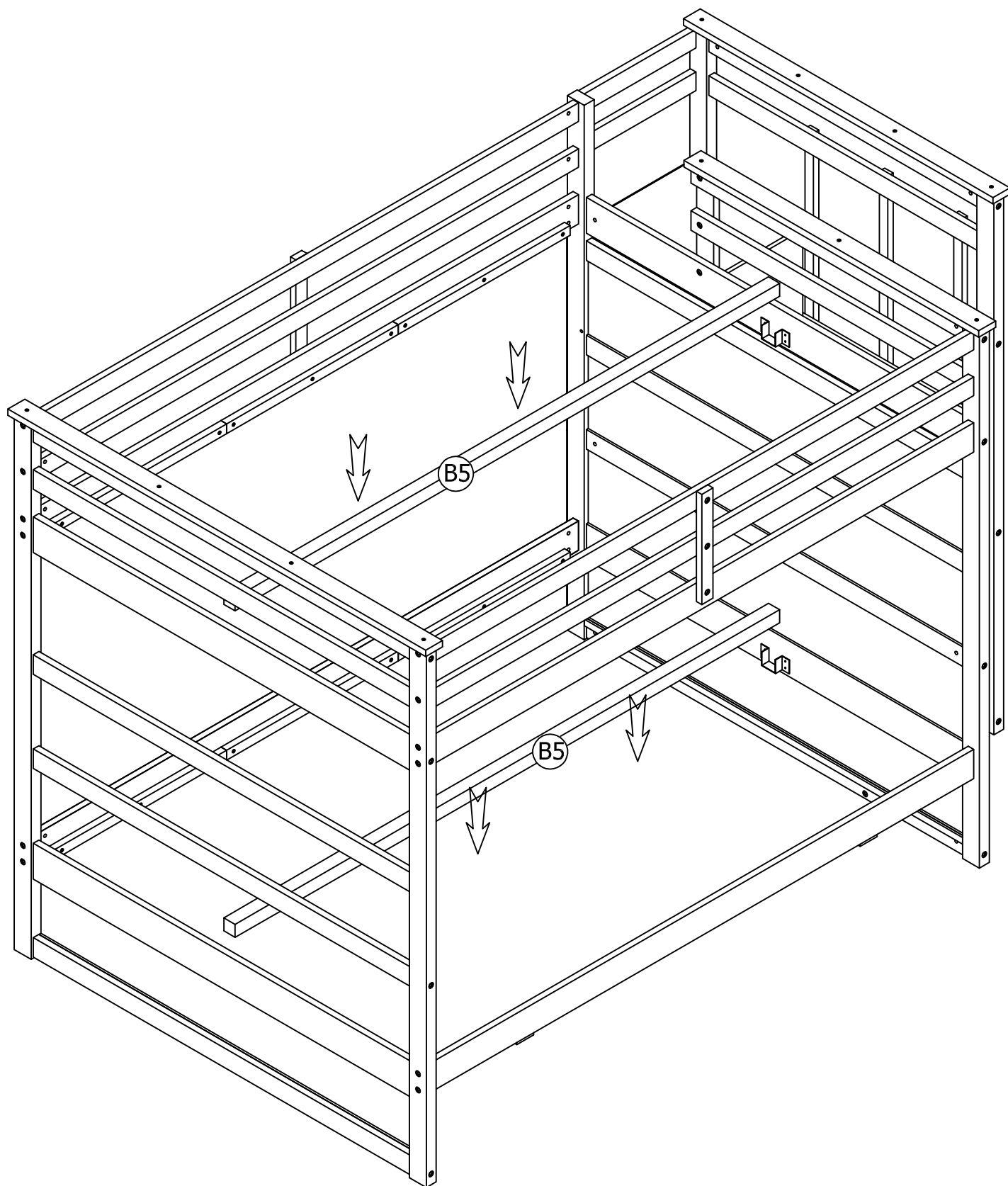

STEP 22:

Étape 22:

12

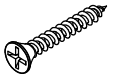

56(pcs)

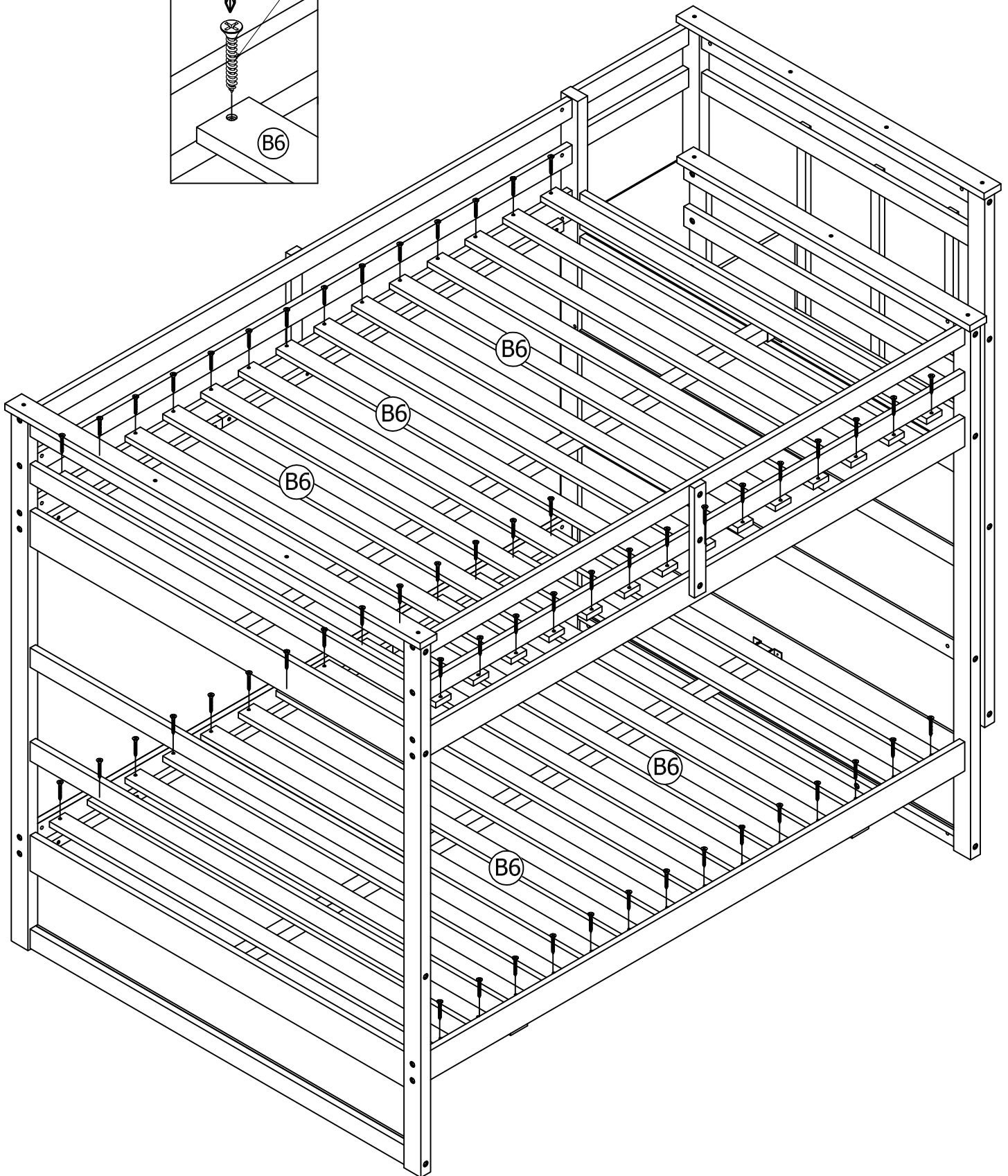
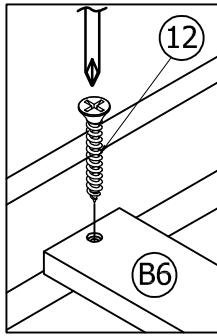

STEP 23:

Étape 23:

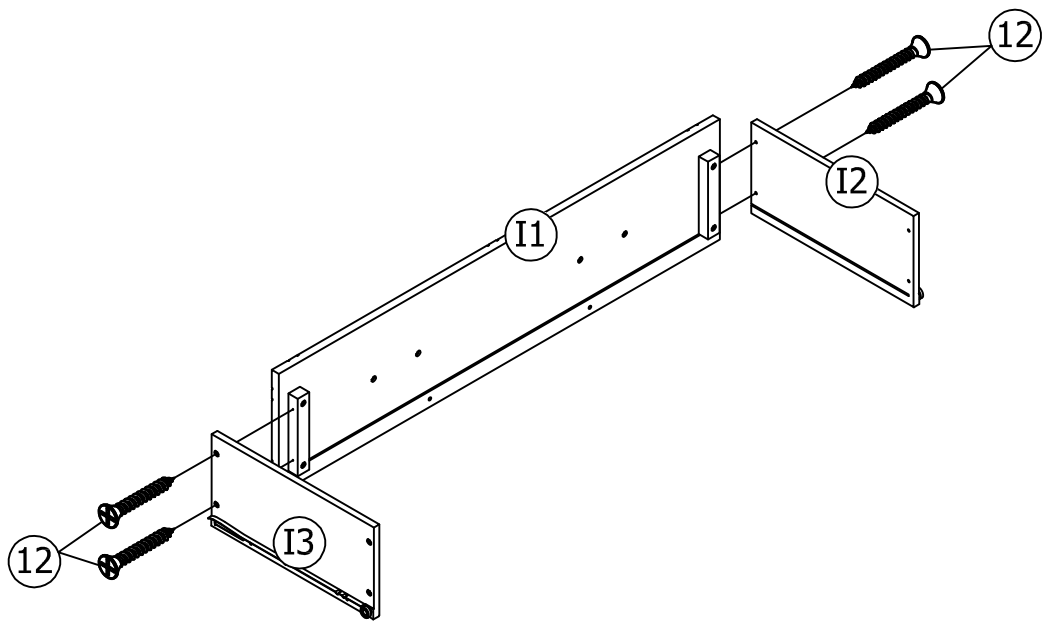

12



4(pcs)

STEP 24:

Étape 24:

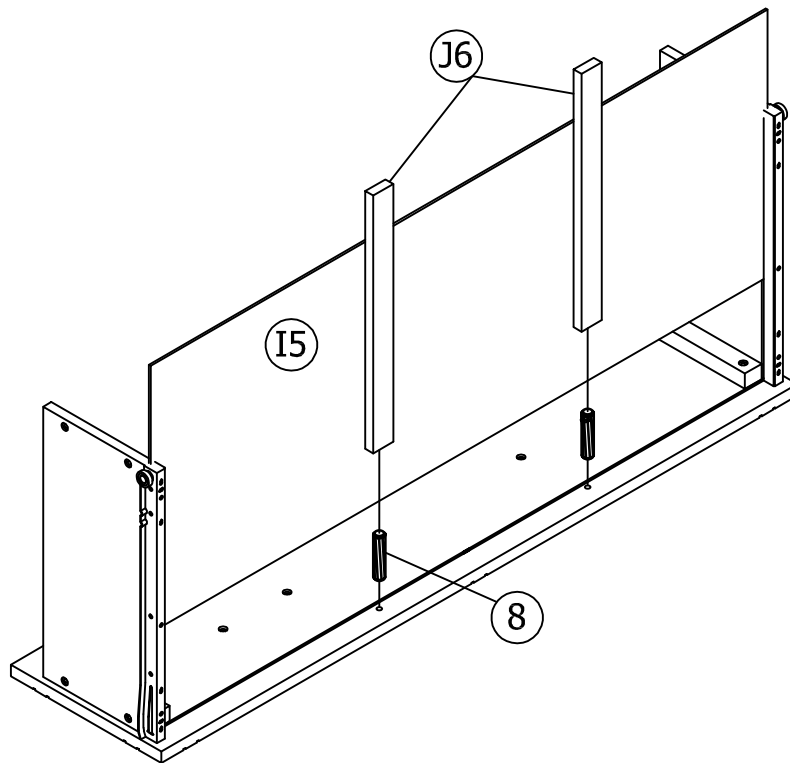

8





2(pcs)

STEP 25:

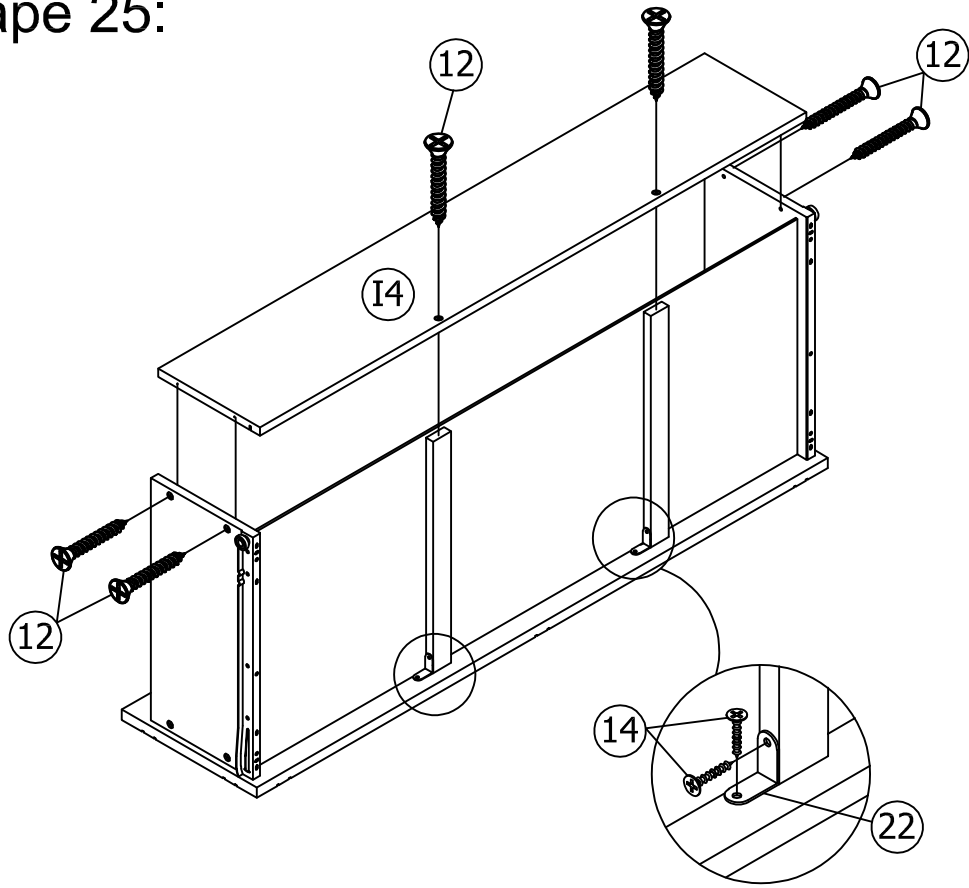
Étape 25:

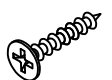

12	14
	
6(pcs)	4(pcs)
	22
	
	2(pcS)

STEP 26:

Étape 26:

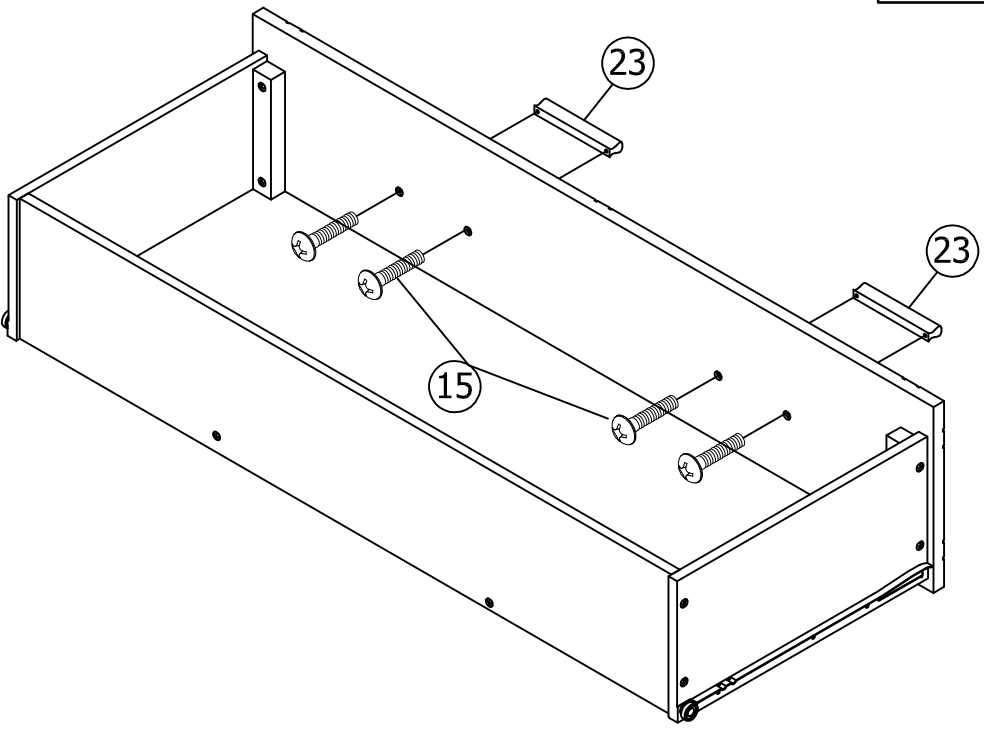

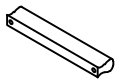
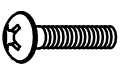
23	15
	
2(pcs)	4(pcs)

STEP 27:

Étape 27:

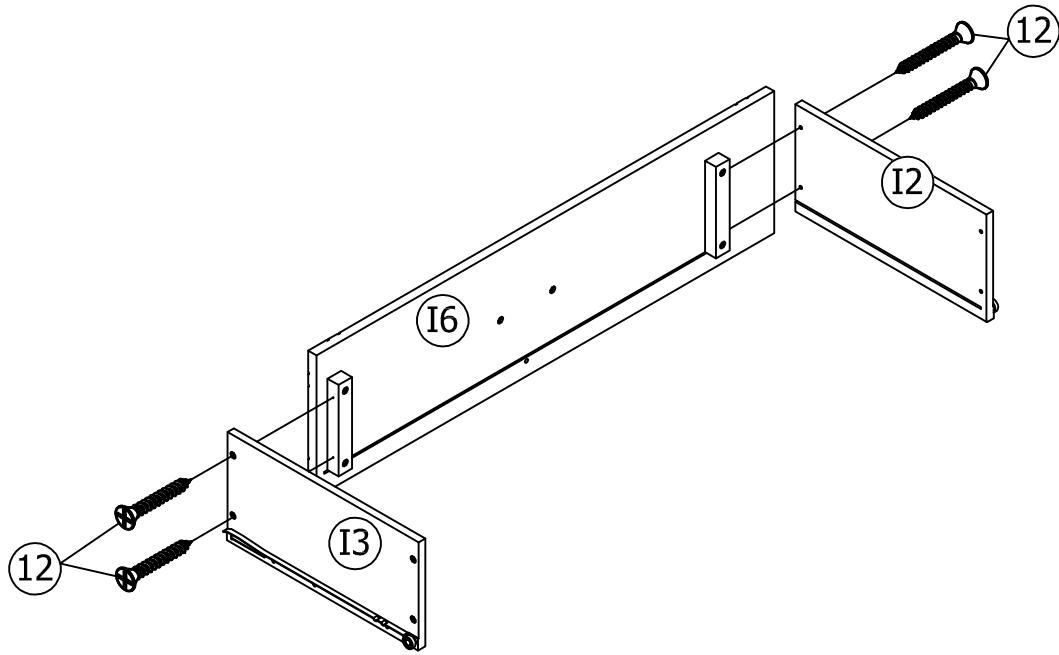

12



4(pcs)

STEP 28:

Étape 28:

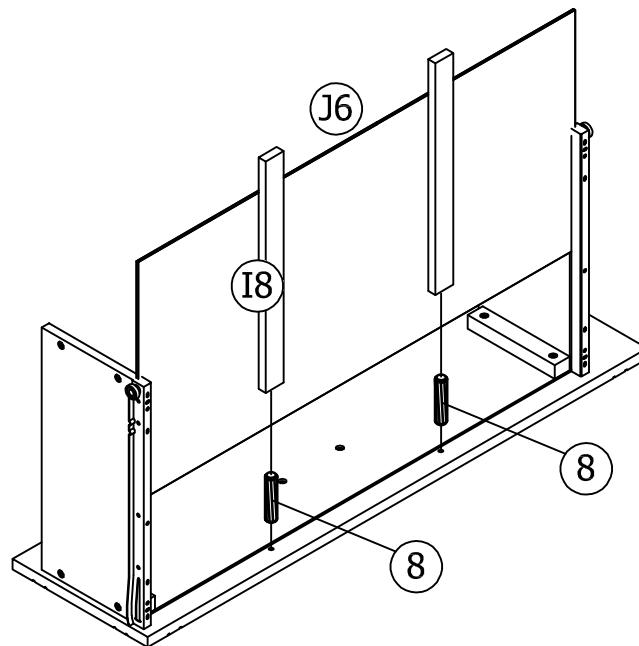

8





2(pcs)

STEP 29:

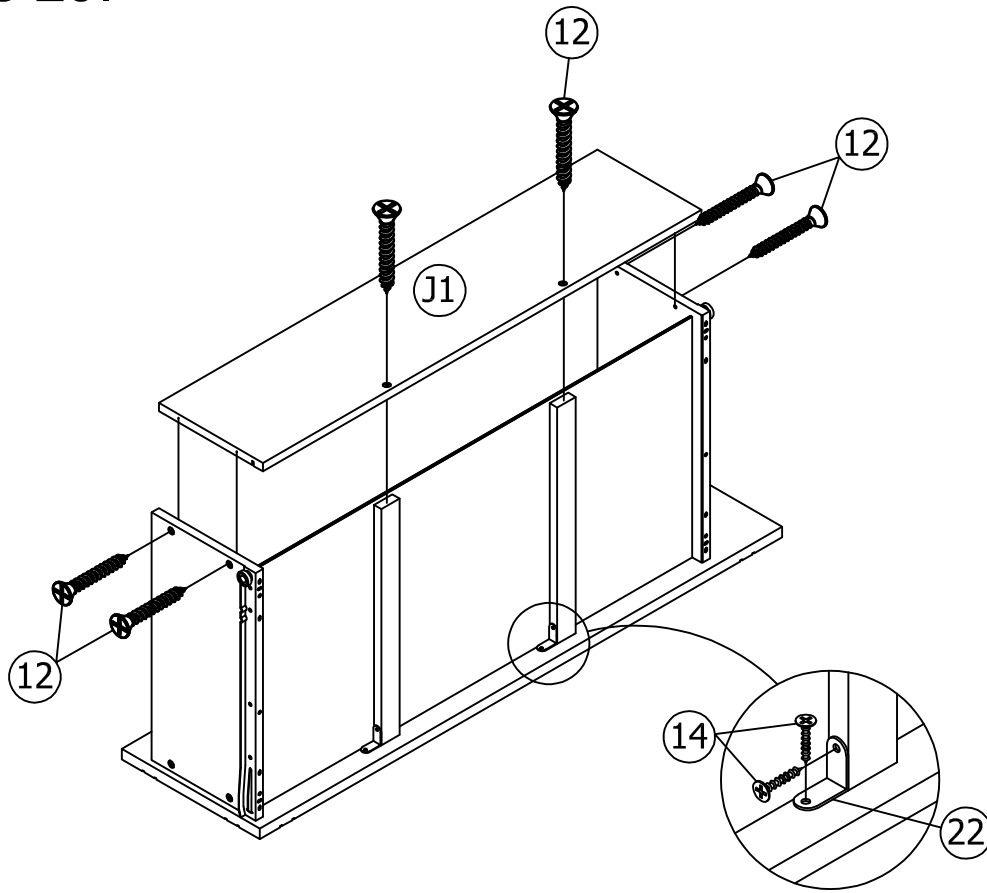
Étape 29:



12	14
	
6(pcs)	4(pcs)
	22
	
	2(pcs)

STEP 30:

Étape 30:

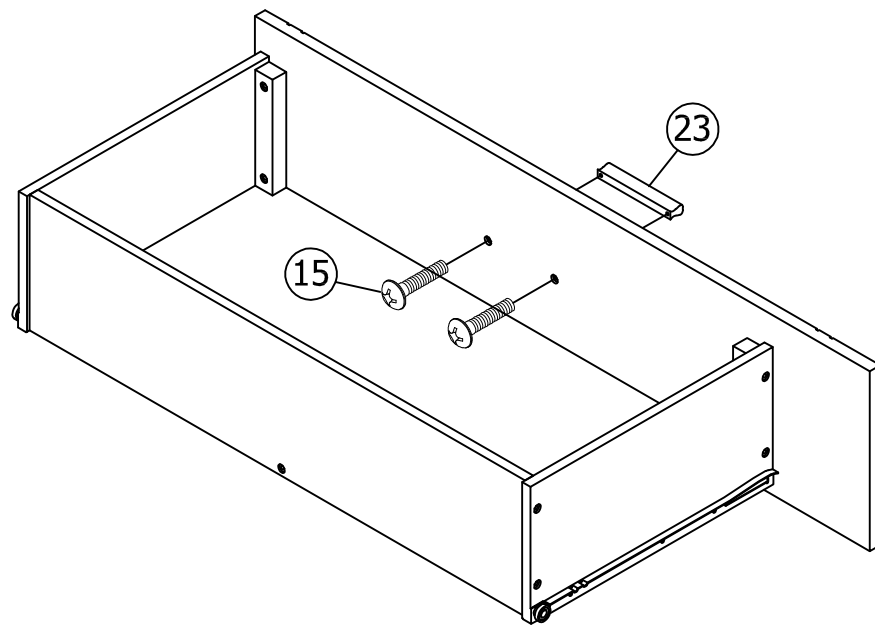

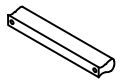
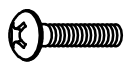
23	15
	
1(pc)	2(pcs)

STEP 31:

Étape 31:

12



4(pcs)

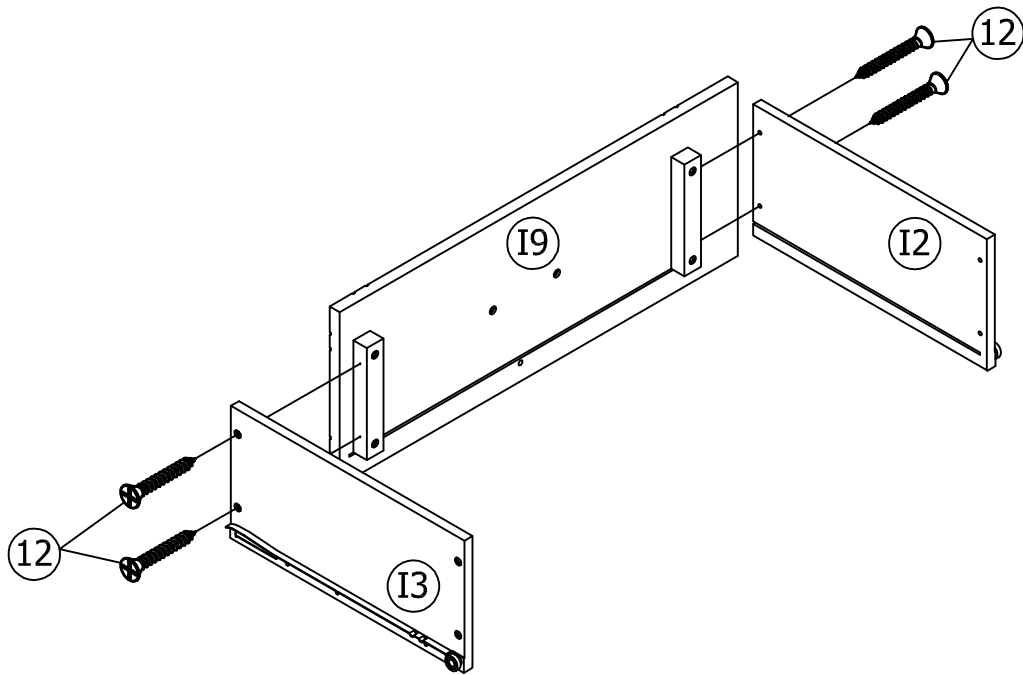

STEP 32:

Étape 32:

8





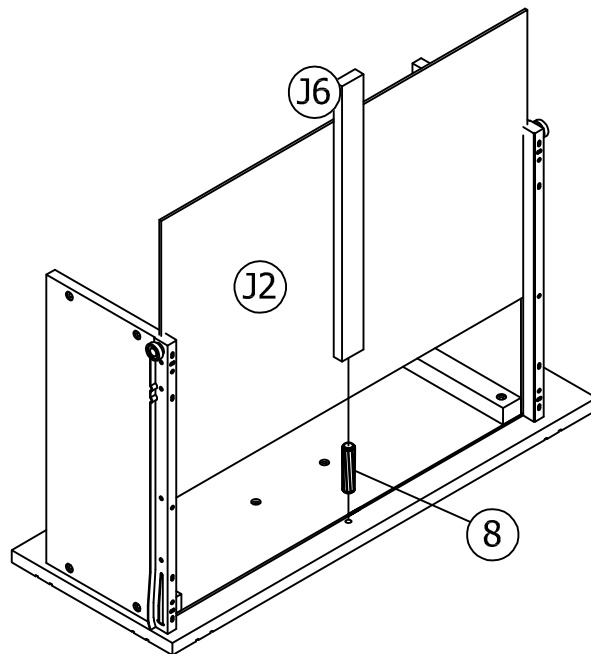

1(pc)

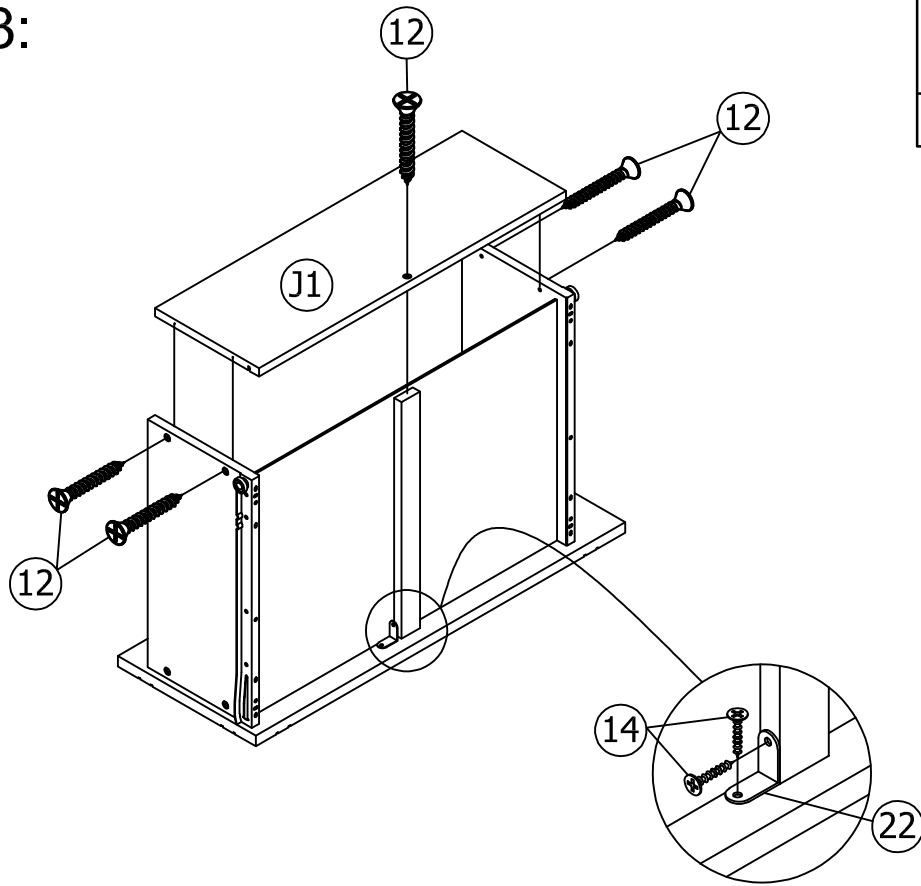

STEP 33:

Étape 33:

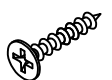

12	14
	
5(pcs)	2(pcs)
	22
	
	1(pc)

STEP 34:

Étape 34:

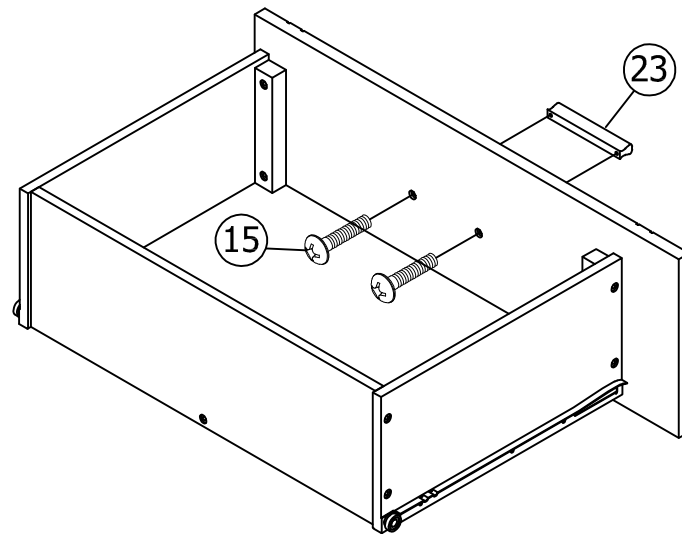

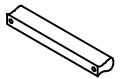
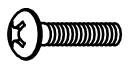
23	15
	
1(pc)	2(pcs)

STEP 35:

Étape 35:

12



4(pcs)

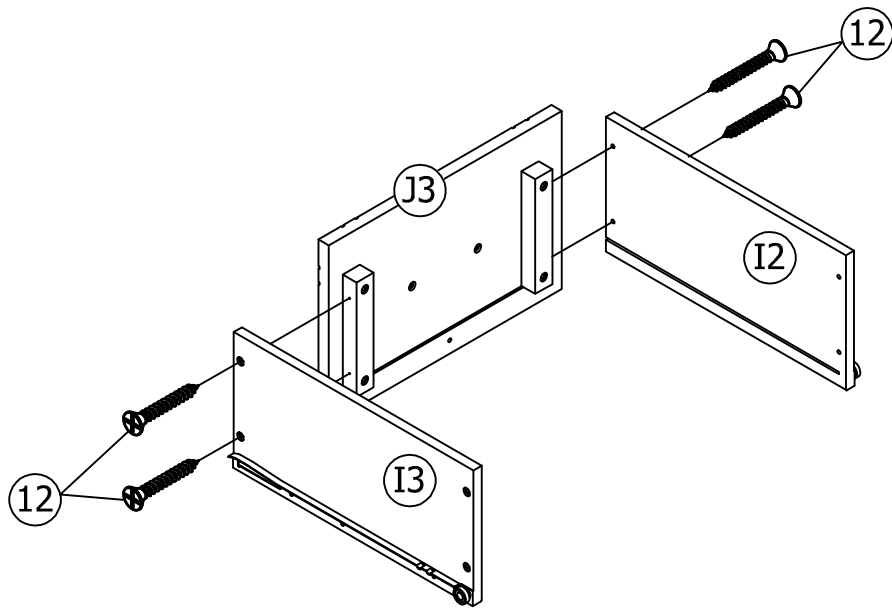

STEP 36:

Étape 36:

8





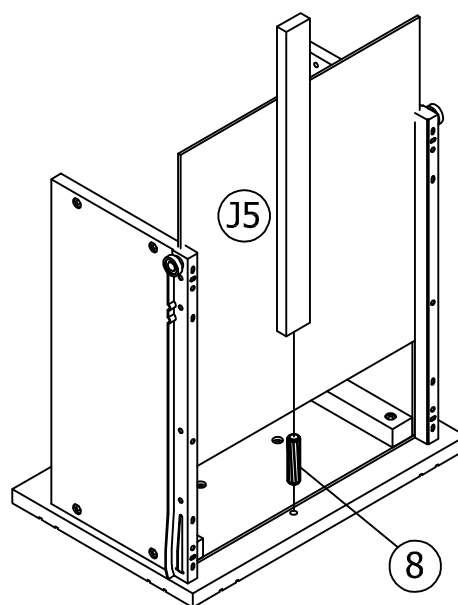

1(pc)

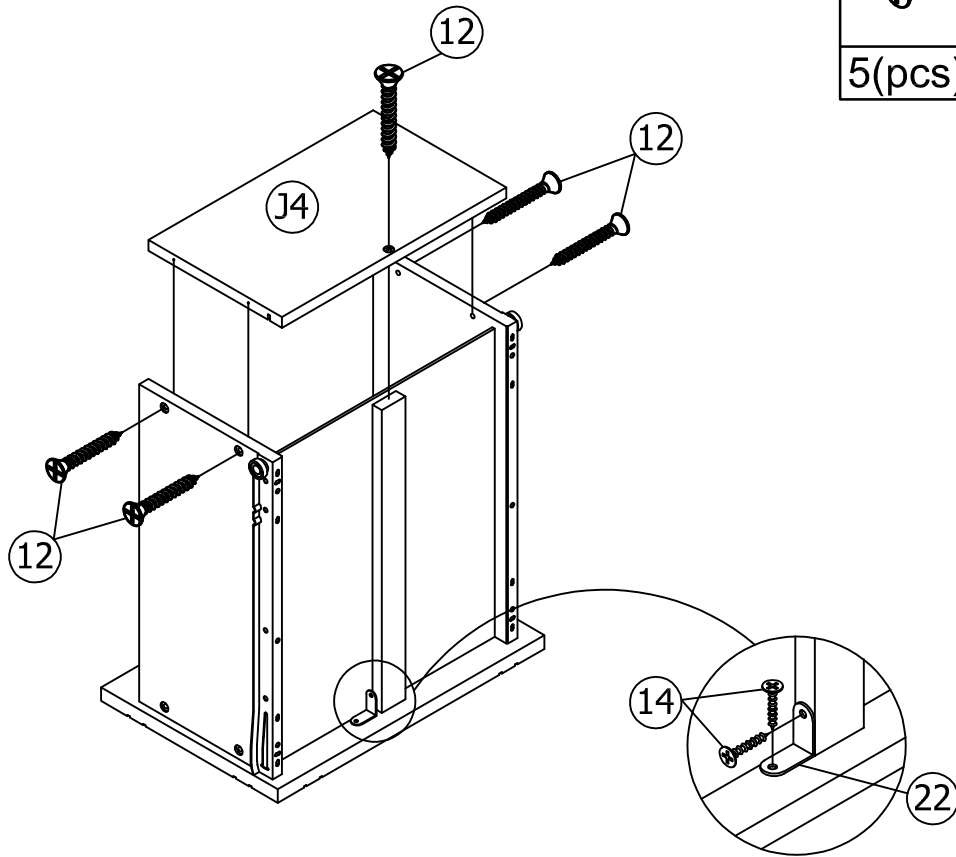

STEP 37:

Étape 37:

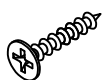

12	14
	
5(pcs)	2(pcs)
	22
	
	1(pc)

STEP 38:

Étape 38:

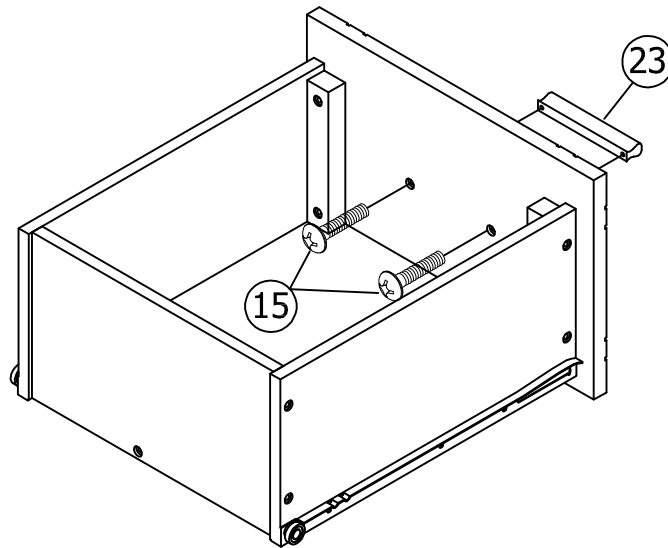

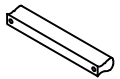
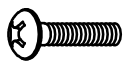
23	15
	
1(pc)	2(pcs)

STEP 39:

Étape 39:

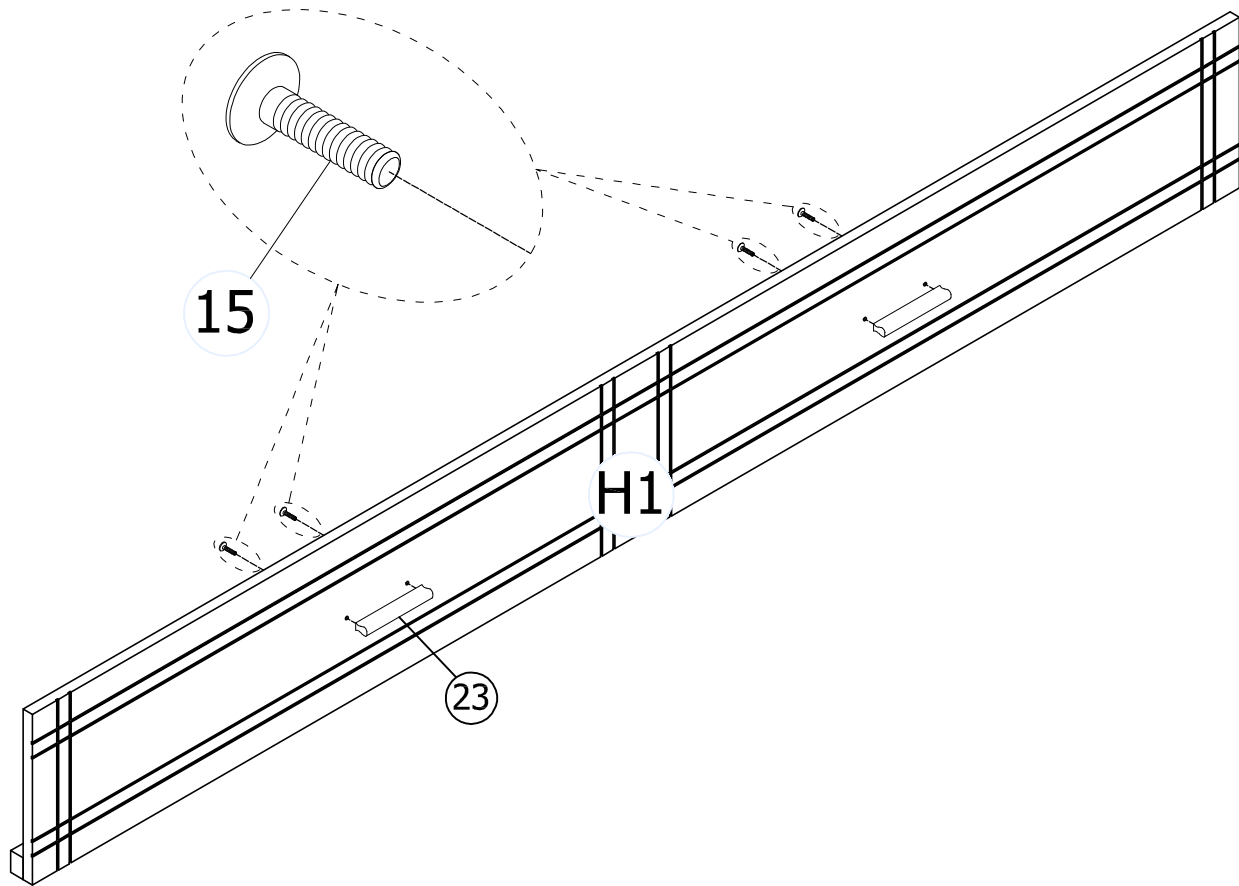

15



4pcs

23

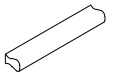

2pcs

STEP 40:

Étape 40:

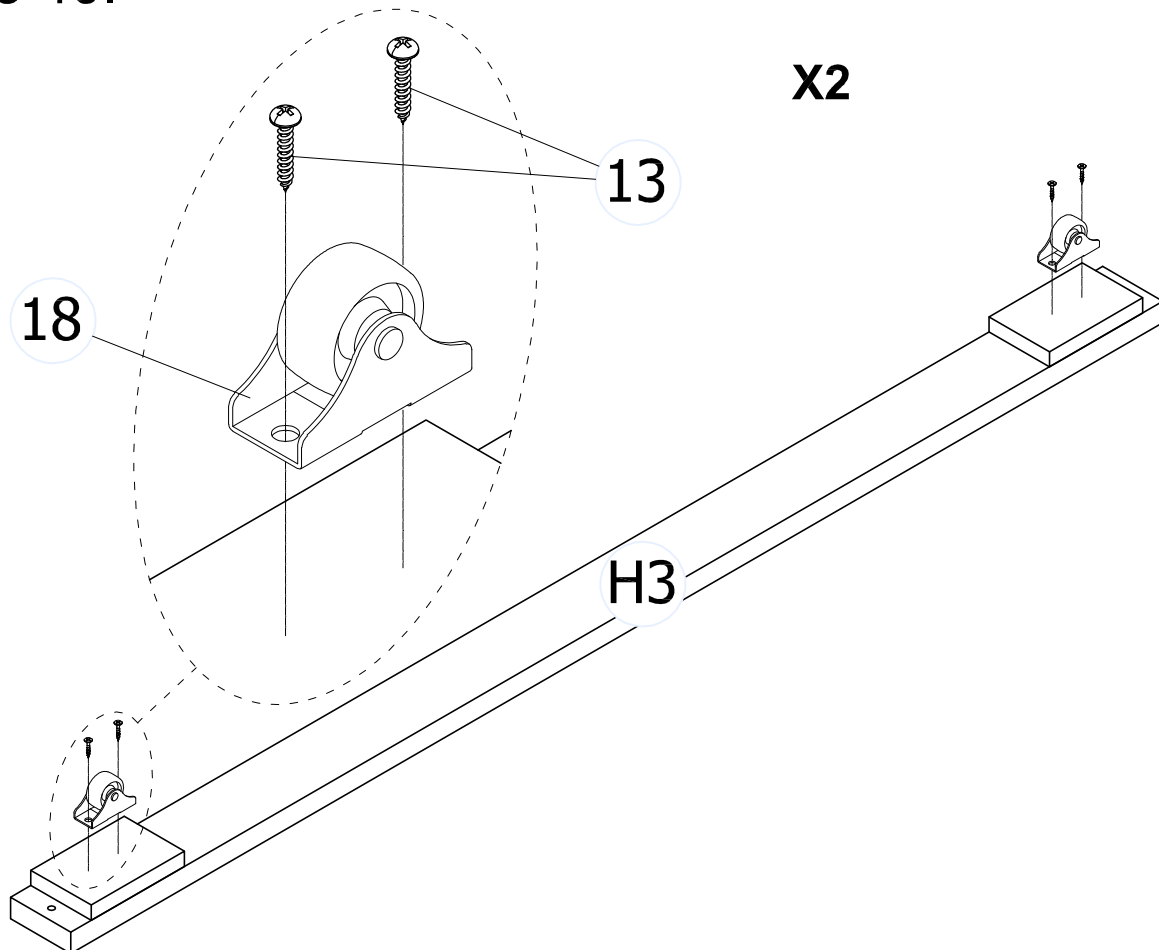

13

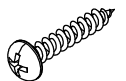

8pcs

18

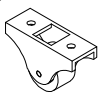

4pcs

STEP 41:

Étape 41:

12



14pcs

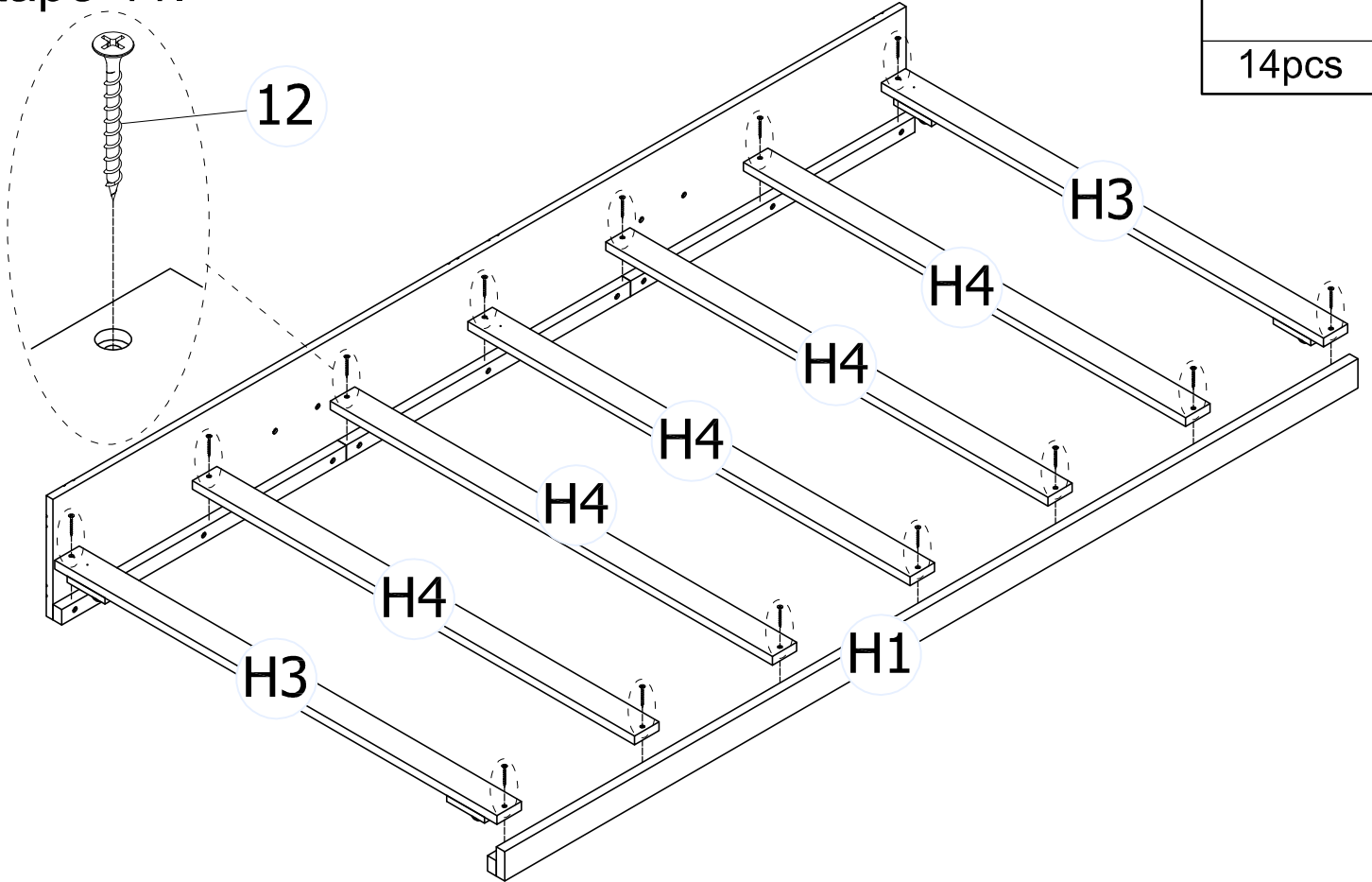

STEP 42:

Étape 42:

13

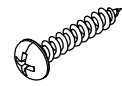

12pcs

19

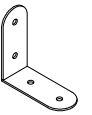

3pcs

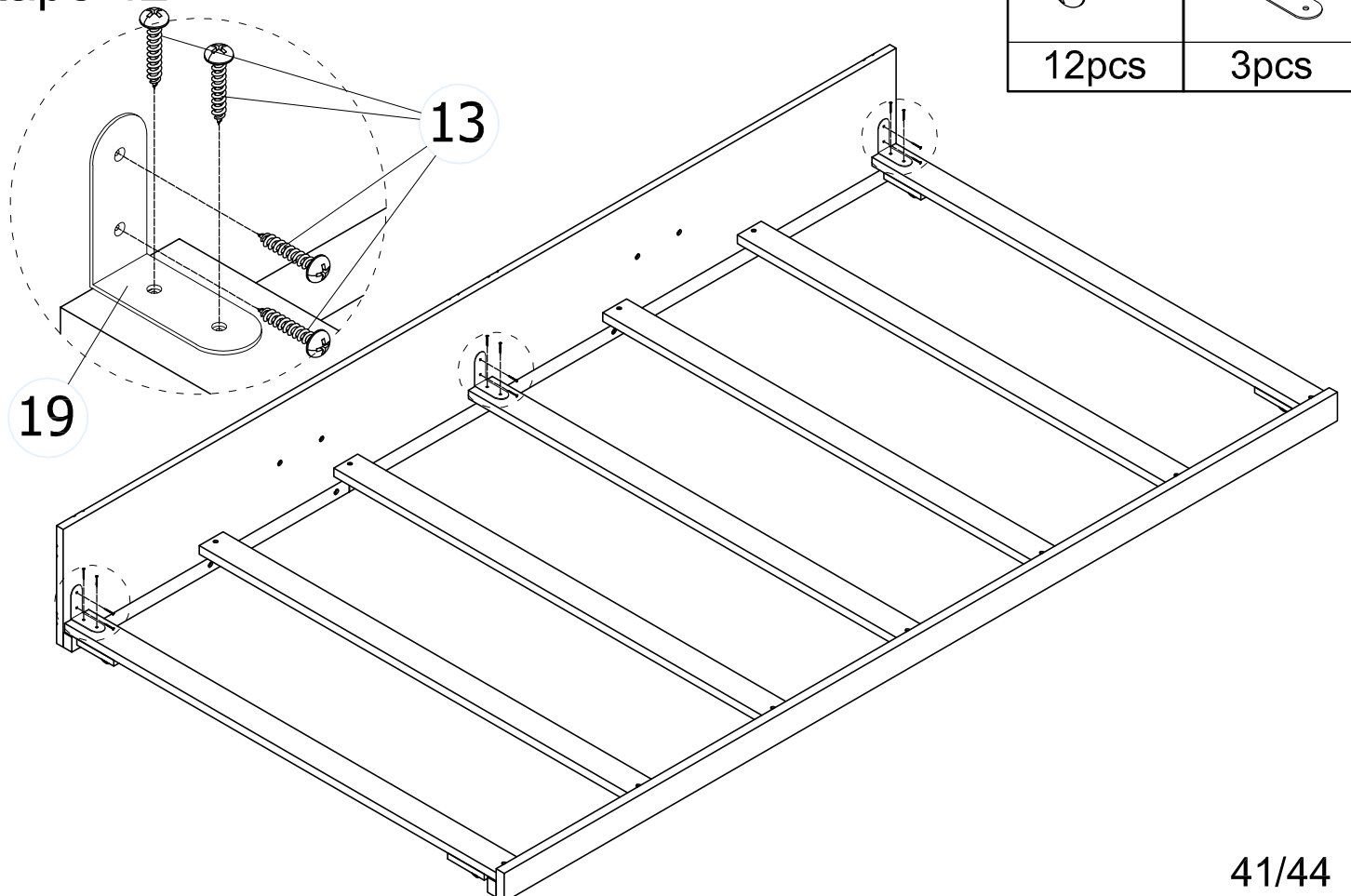

STEP 43:

Étape 43:

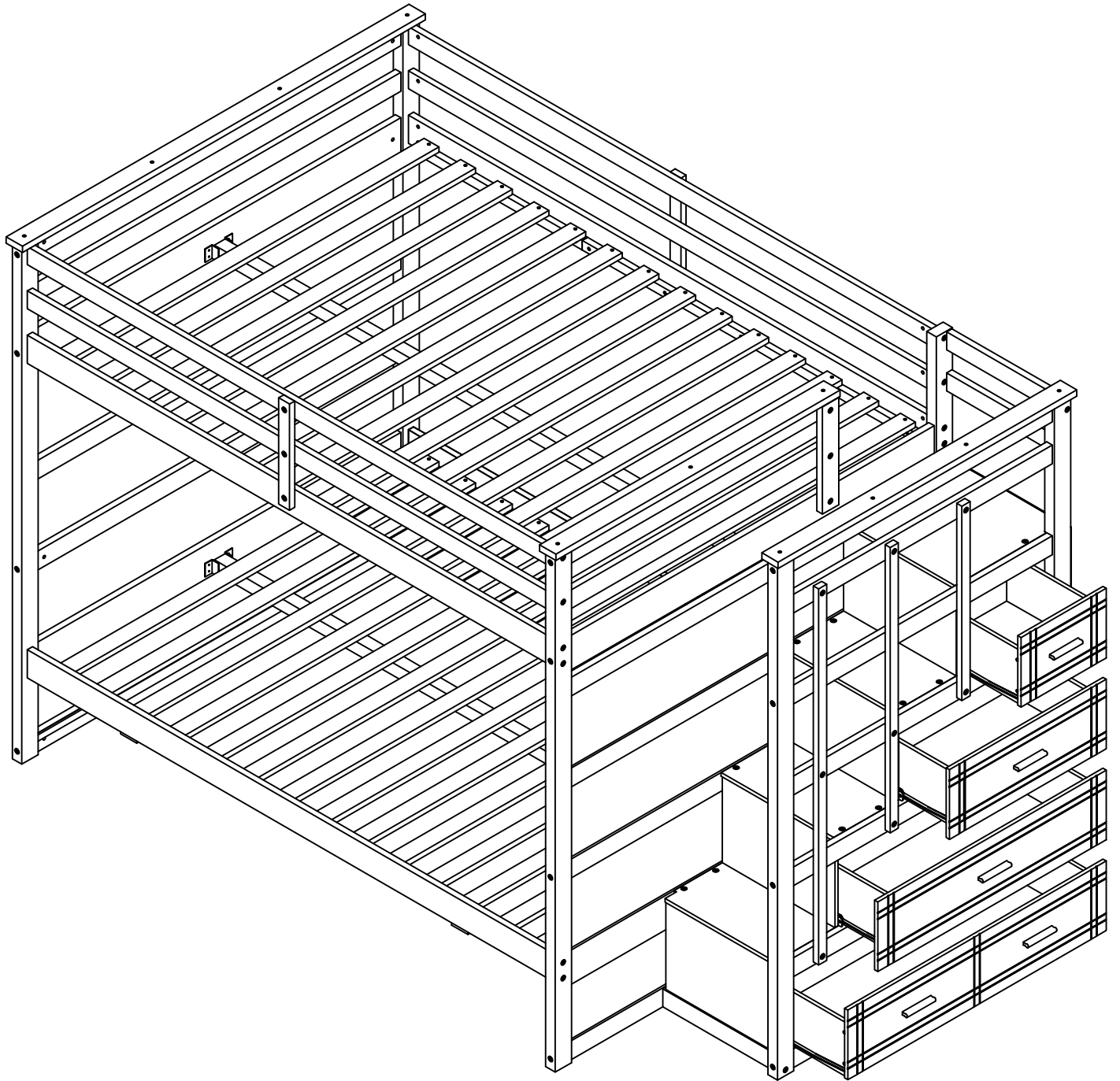

STEP 44:

Étape 44:

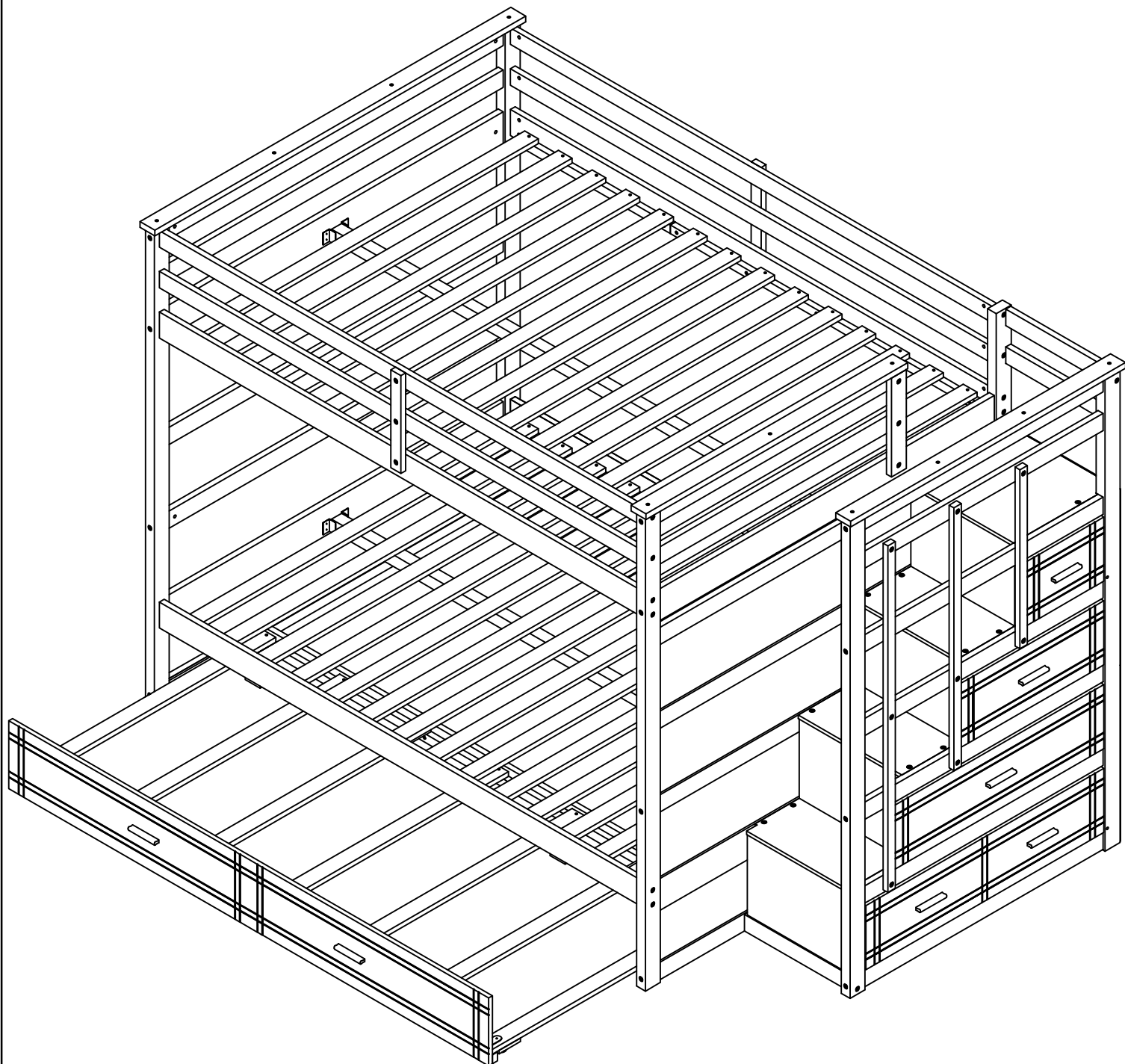

FINISH:

