

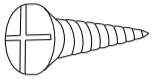
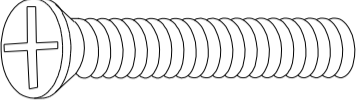
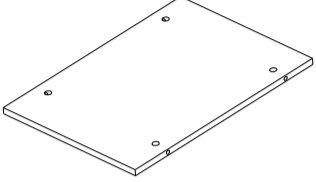
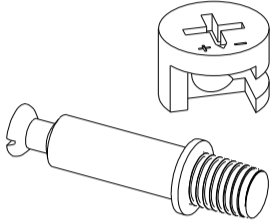
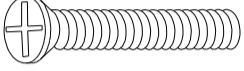
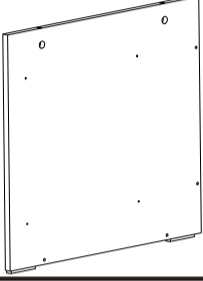

READ AND SAVE THIS INSTRUCTION FOR FUTURE USE

# ASSEMBLY INSTRUCTION

# PACKING DETAILS: TOTAL 2 BOXES

## BOX-1/2

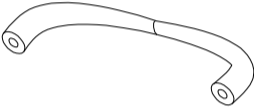
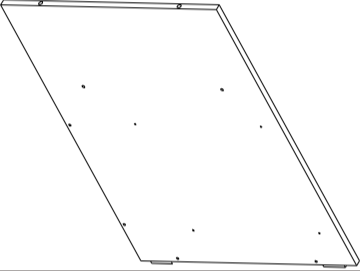
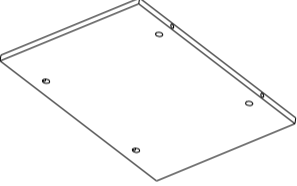
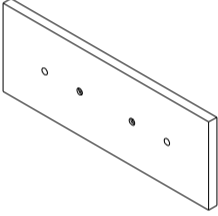
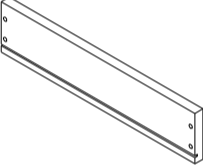
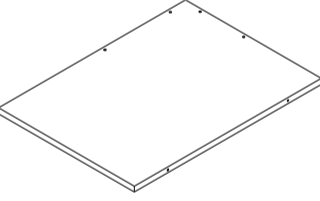
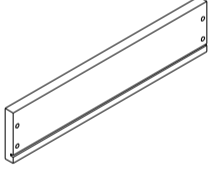
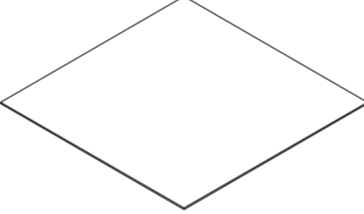
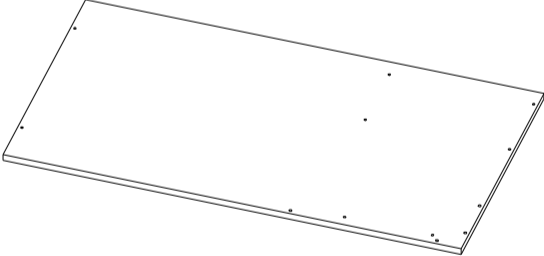
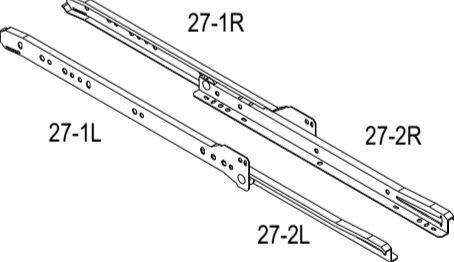

NO.	PARTS	QTY	NO.	PARTS	QTY	NO.	PARTS	QTY
A		16	D		8	①		1
B		46	E		4	②		1
C		22	F		2	③		1
④		1	①⑥		1	②①		1
⑤		1	②⑦		1	③⑥		2
①④		1	③⑦		2			

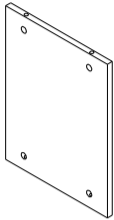
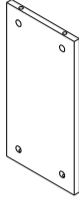
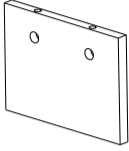
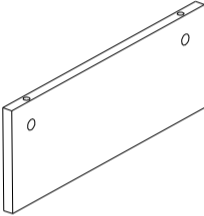
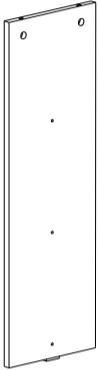
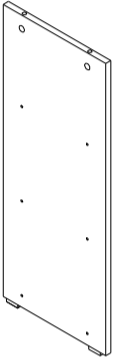
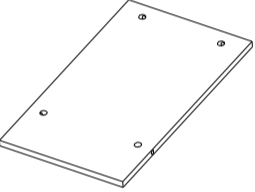
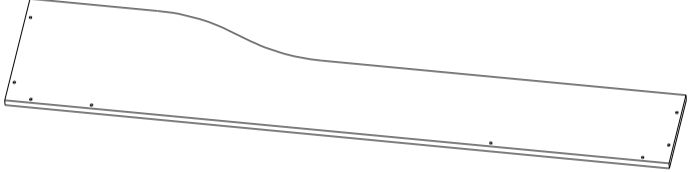
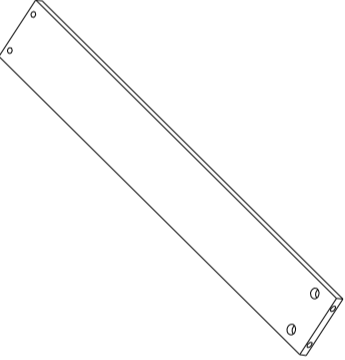
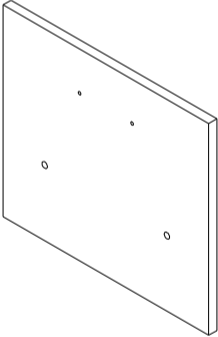
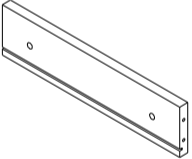
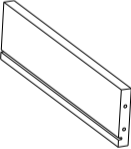
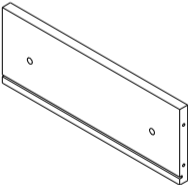
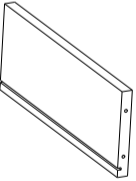
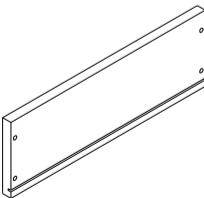
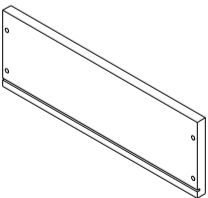
## BOX-2/2

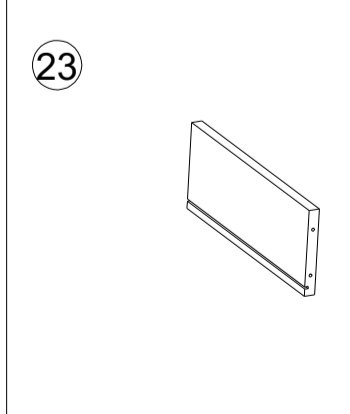
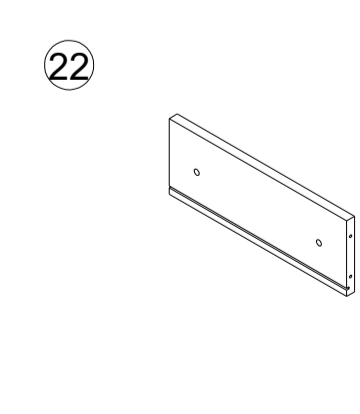
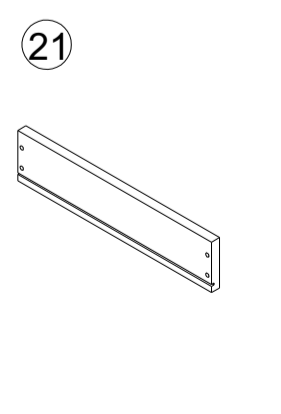
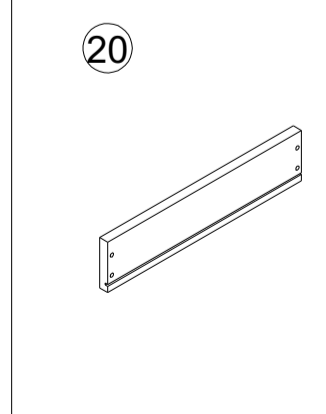
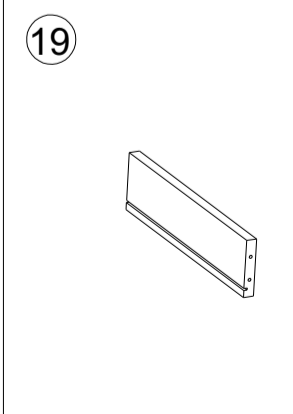
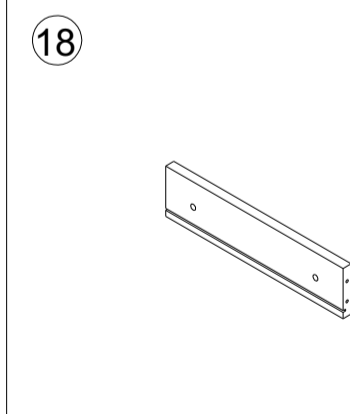
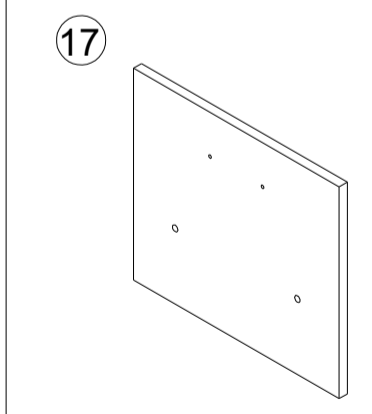
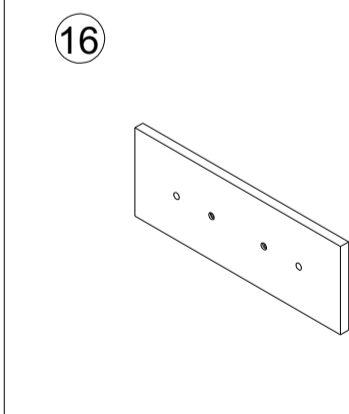
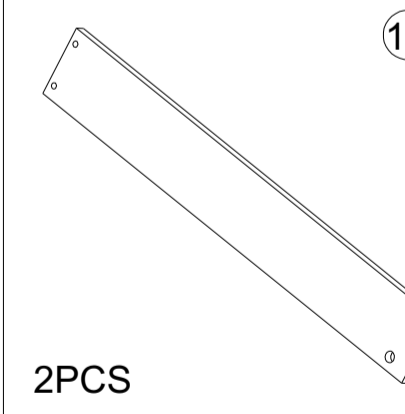
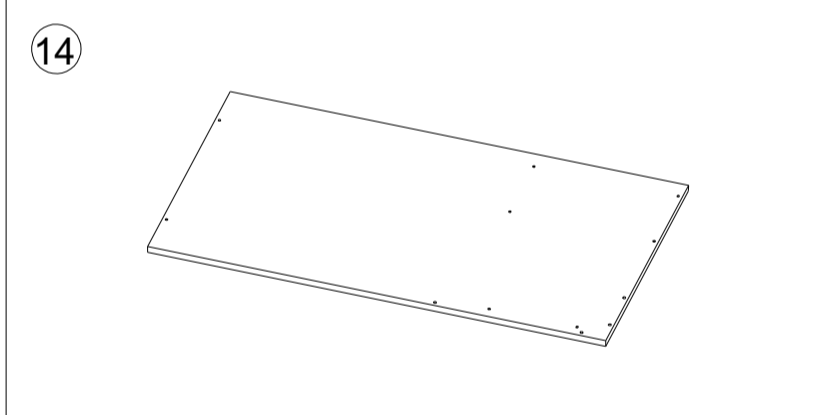
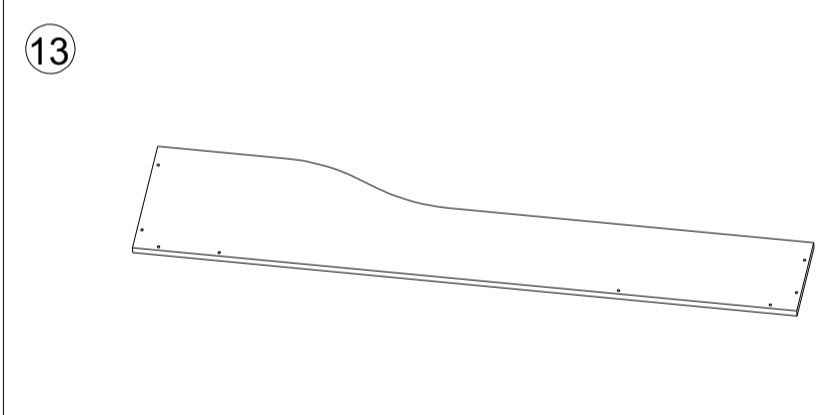
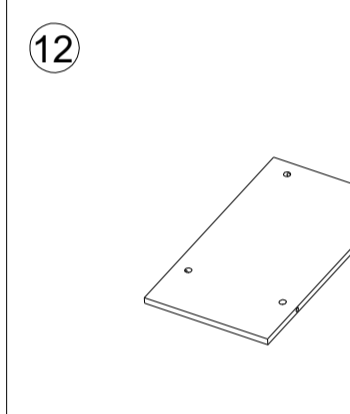
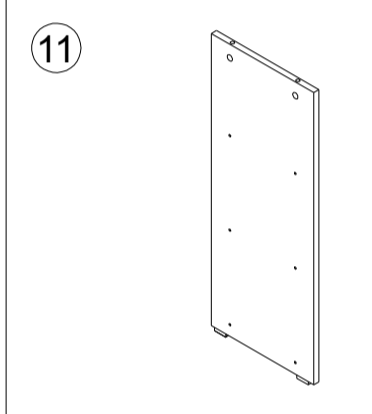
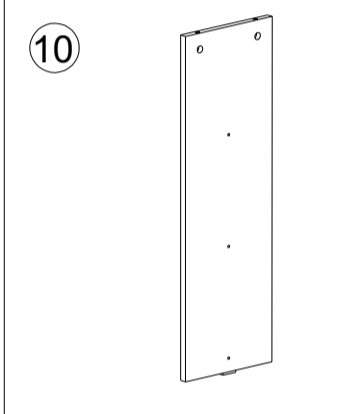
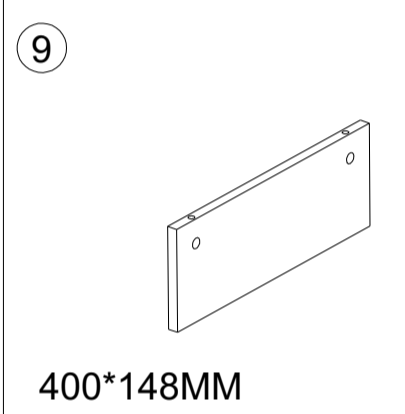
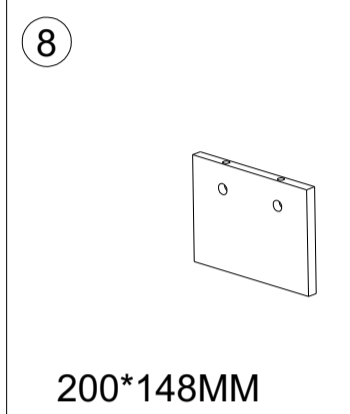
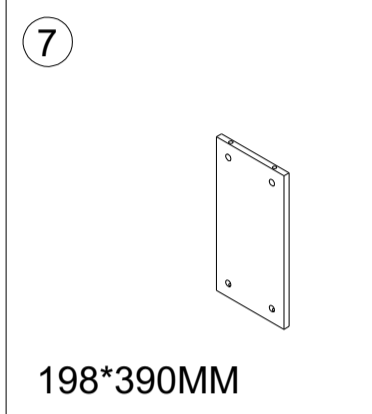
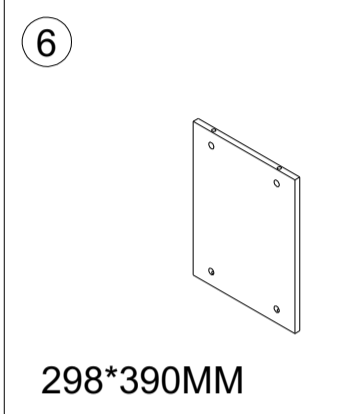
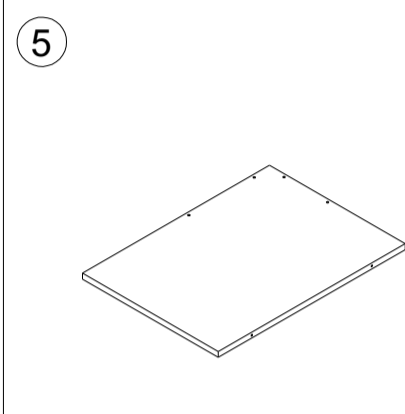
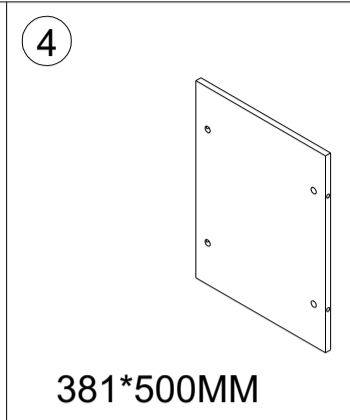
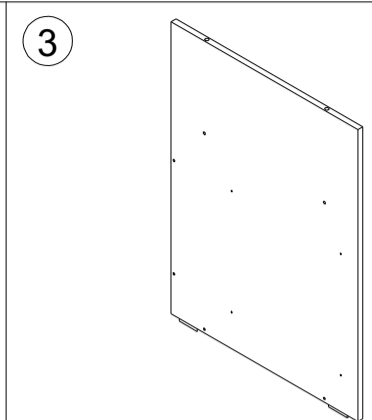
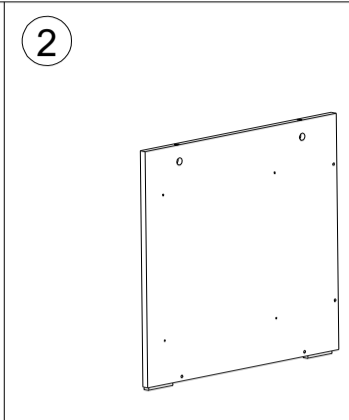
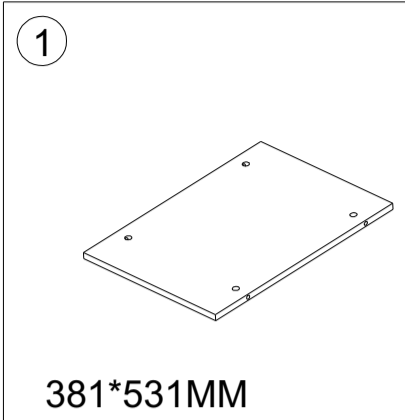
NO.	PARTS	QTY	NO.	PARTS	QTY	NO.	PARTS	QTY
⑥		1	⑦		1	⑧		1
⑨		1	⑩		2	⑪		1
⑫		3	⑬					1
⑮		2	⑰		1	⑱		1
⑲		1	⑳		1	㉓		1
㉔		1	㉕		1			

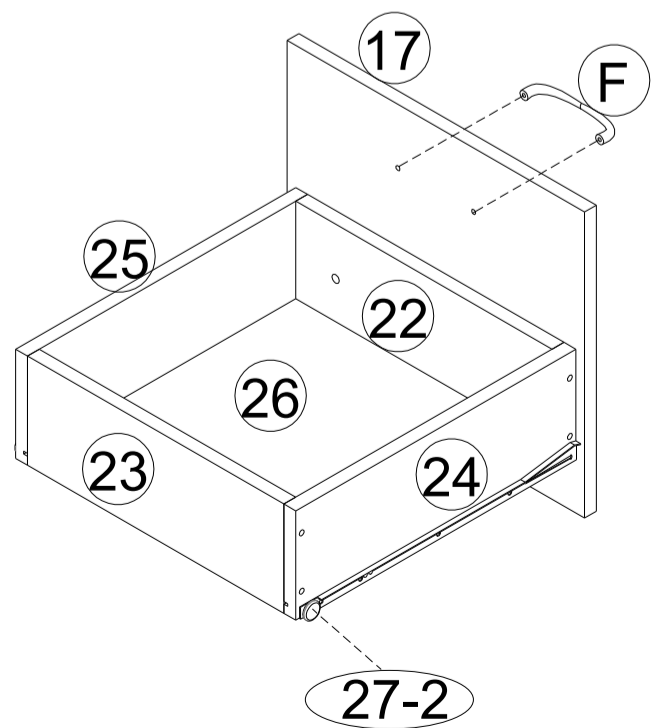
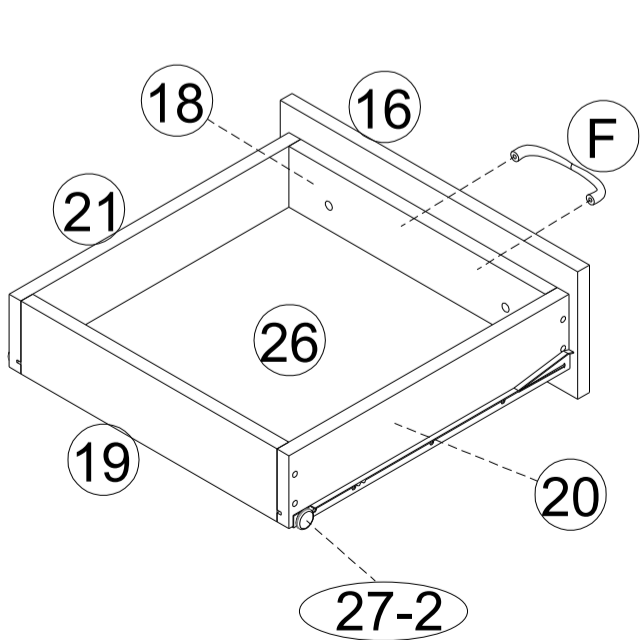
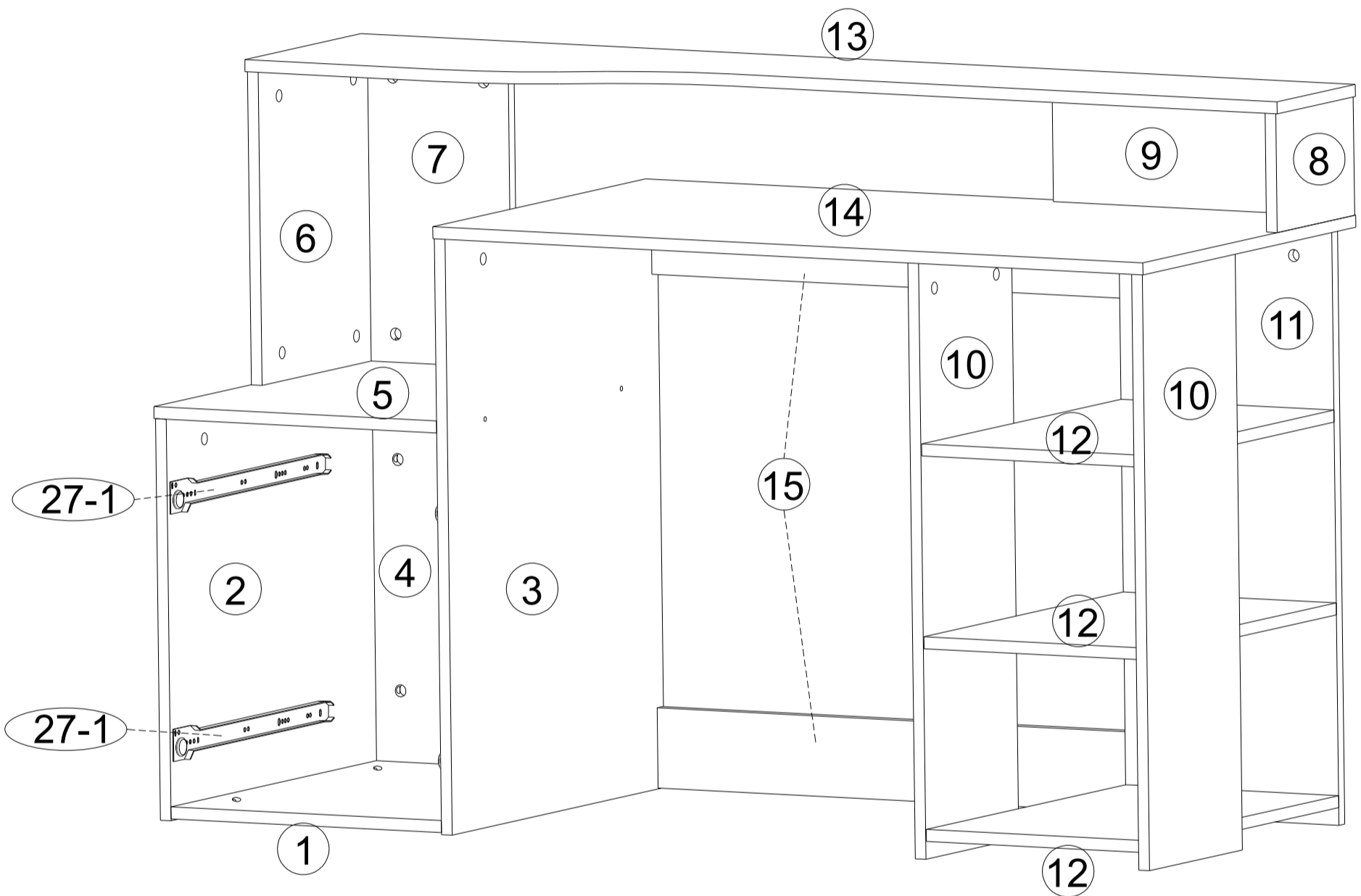
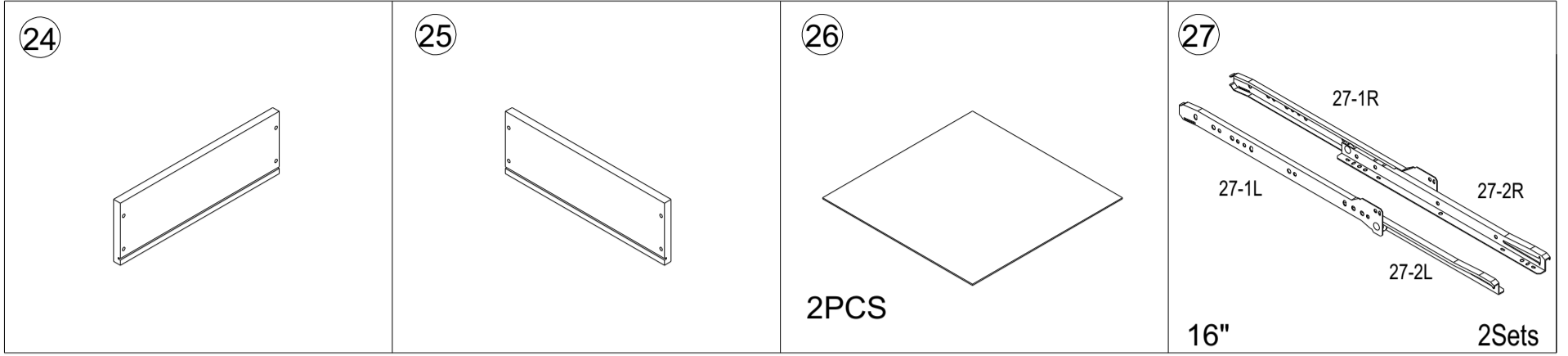

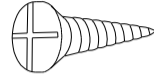
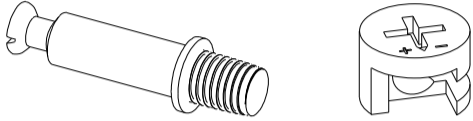

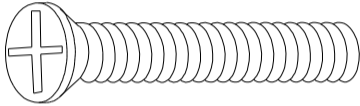
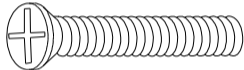
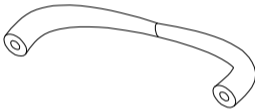
Part.	Item.	QTY.	
A	M3.5X14	16	
B	M5X45	46	
C	M5X40	22	
D	M6X25	8	
E	M4X18	4	
F	M4X96mm	2	

### 5X45mm bolt installation as below

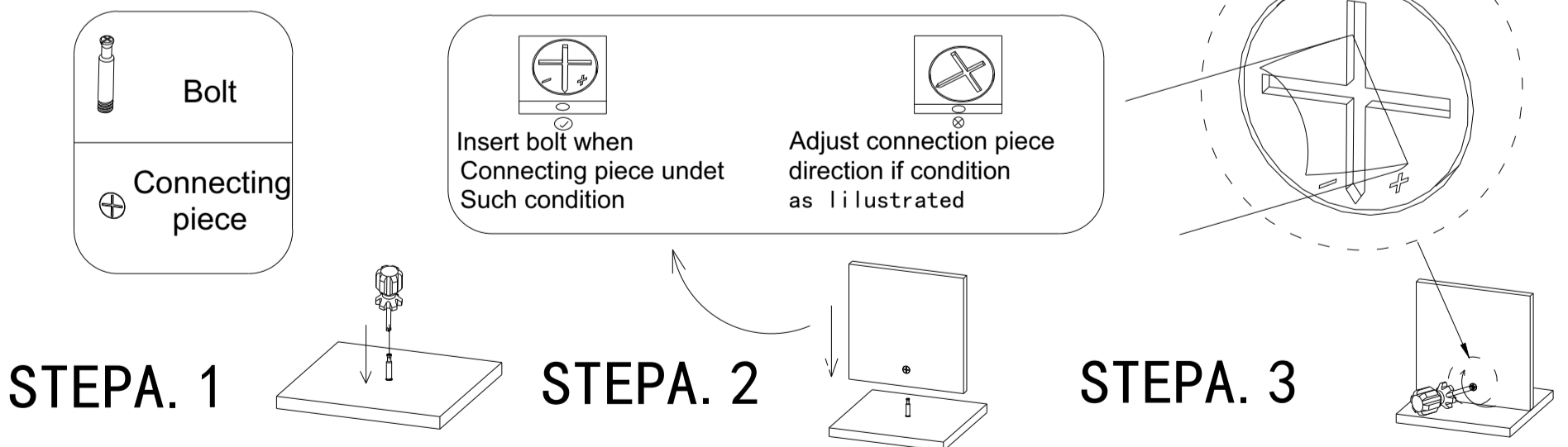

1

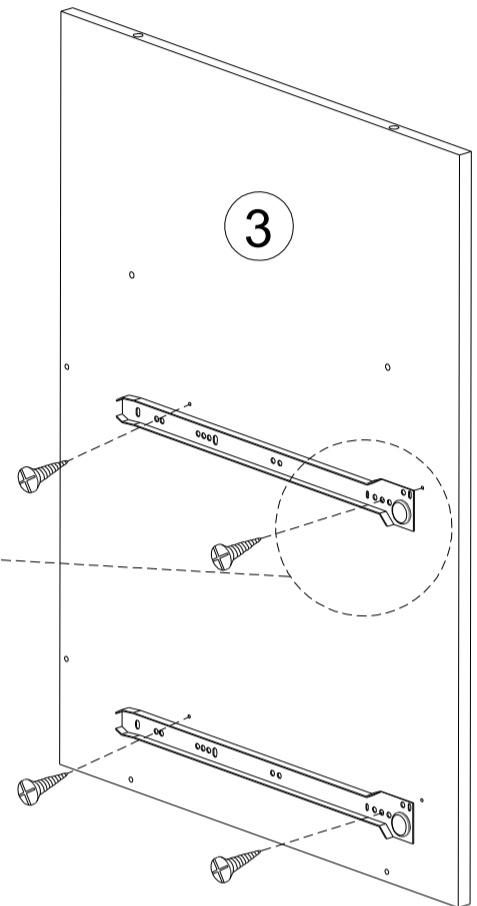
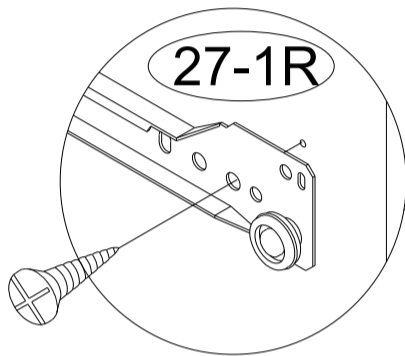
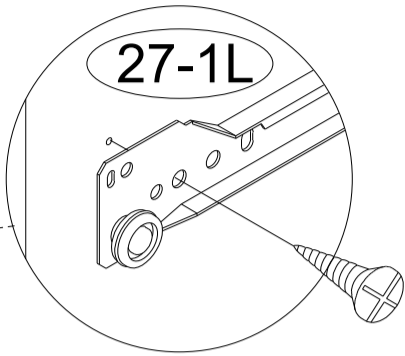
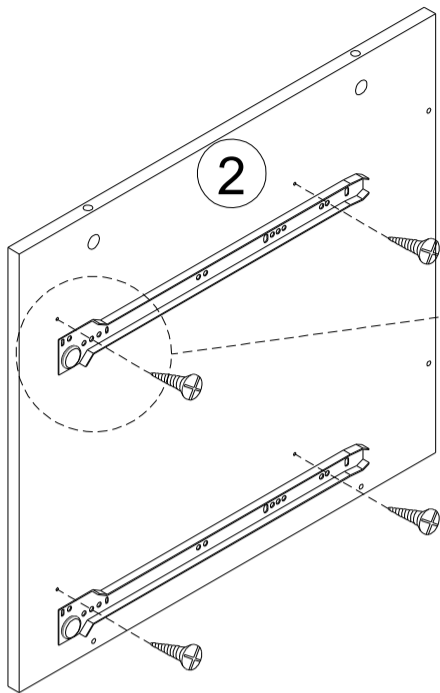

.SCREWS

A M3.5X14  
8 PCS

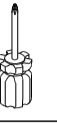
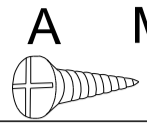

2

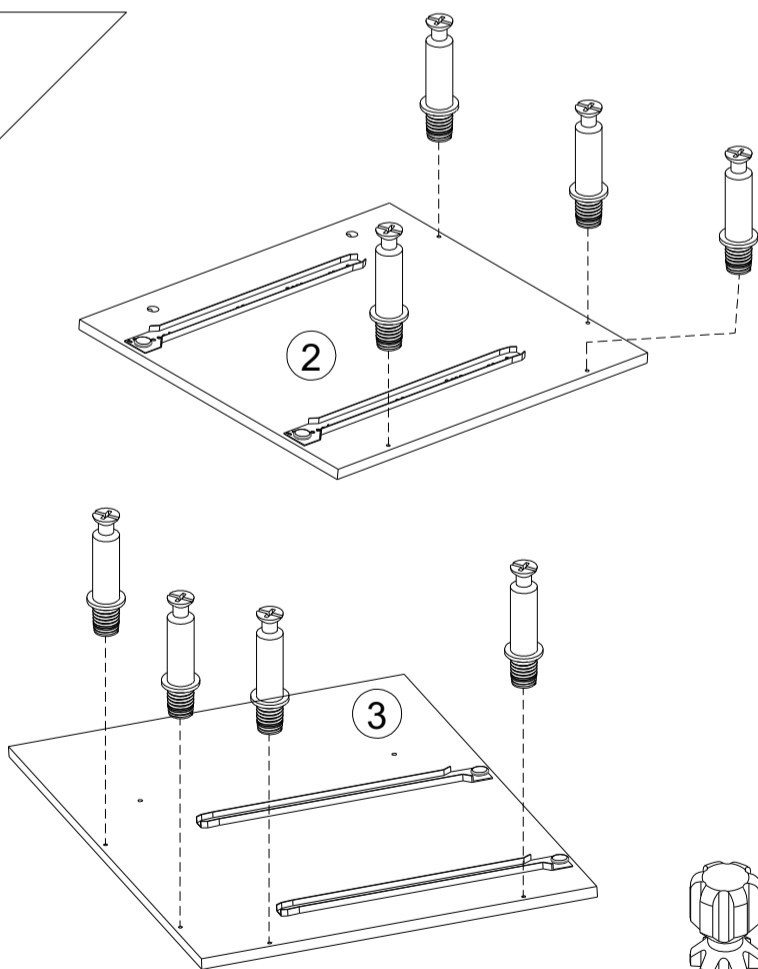

.SCREWS

B M5X45  
8 PCS

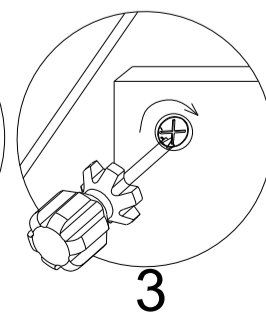
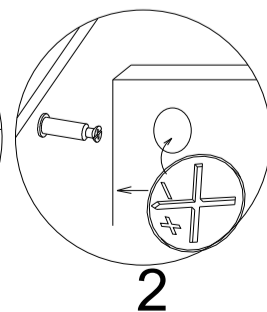
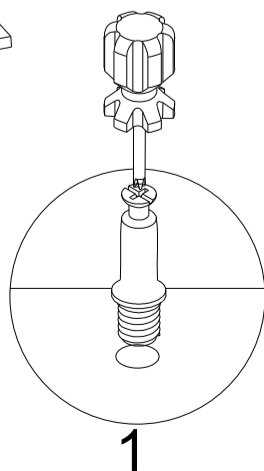
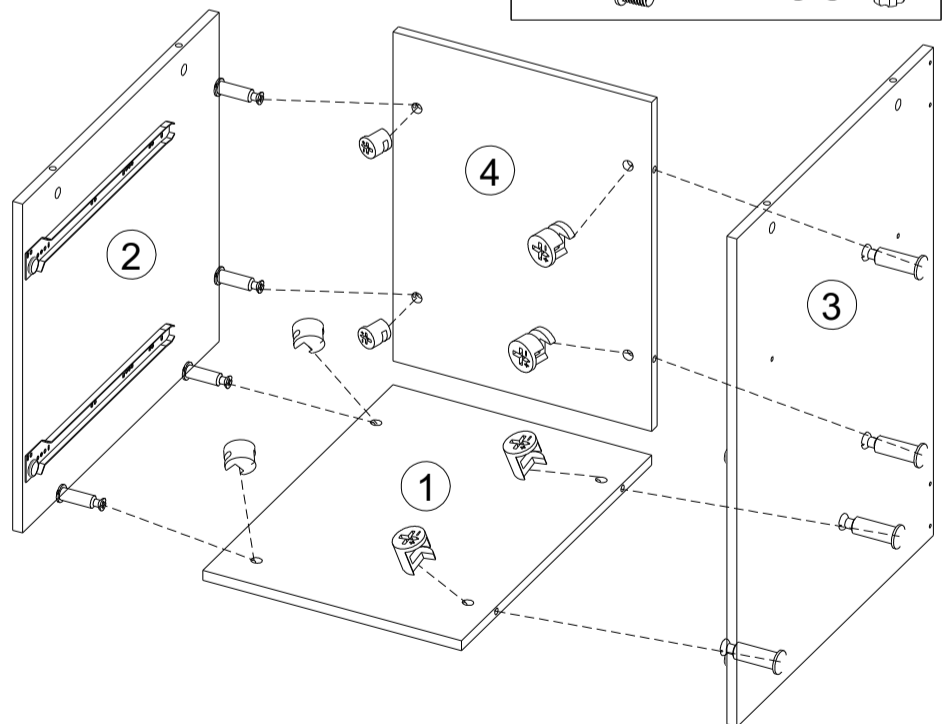
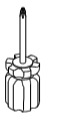
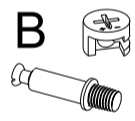

1

2

3

3

.SCREWS

B M5X45  
2 PCS

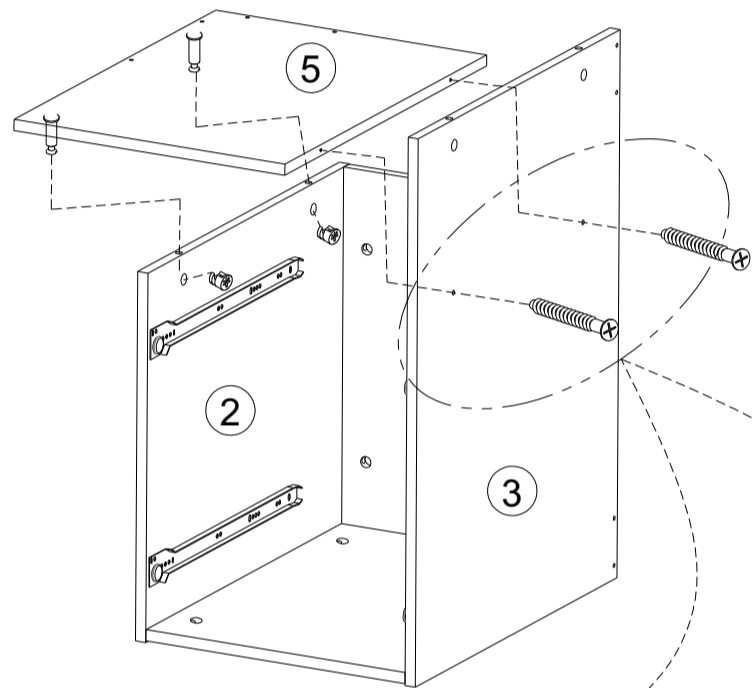
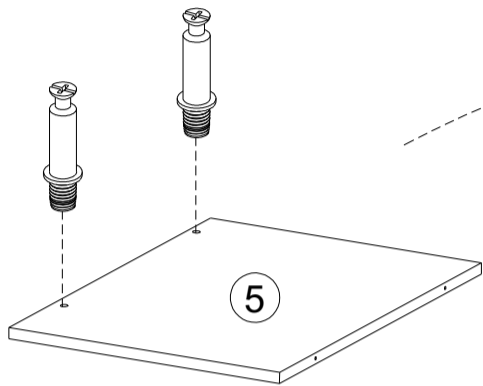
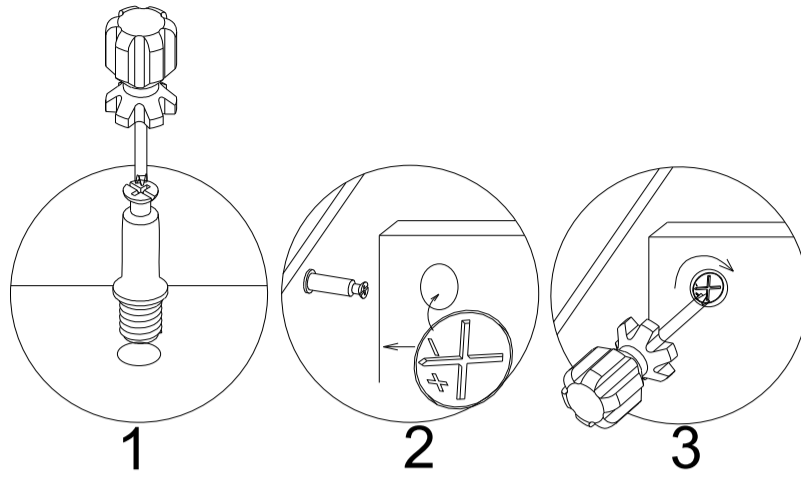

.SCREWS

C M5X40  
2 PCS

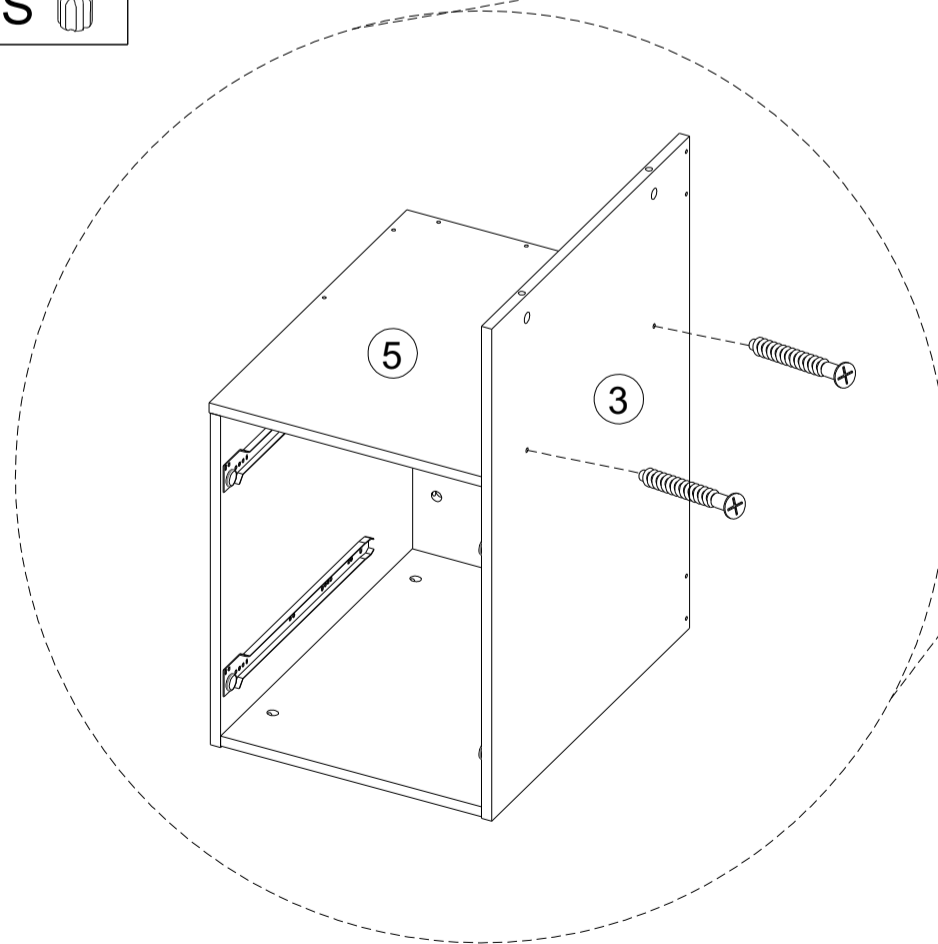

4

.SCREWS  
B  M5X45  
 4 PCS 

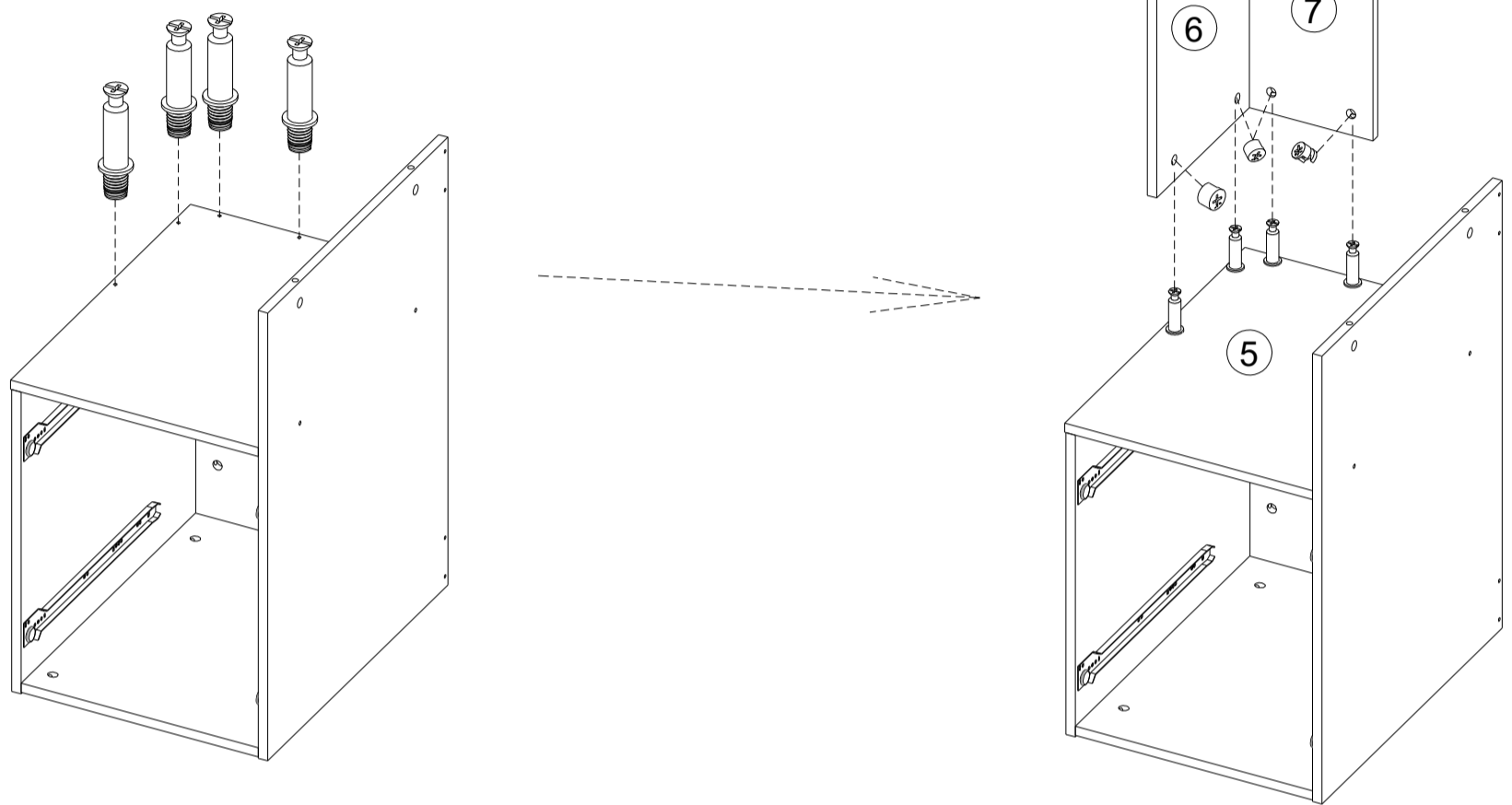
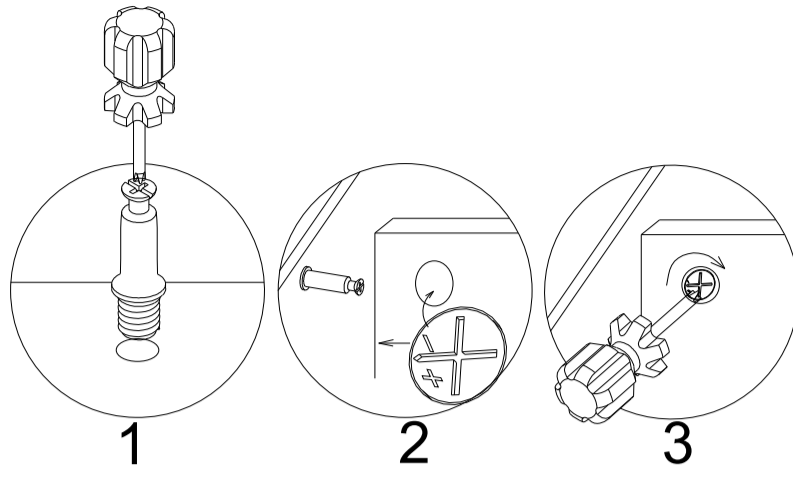

5

.SCREWS  
B  M5X45  
 4 PCS 

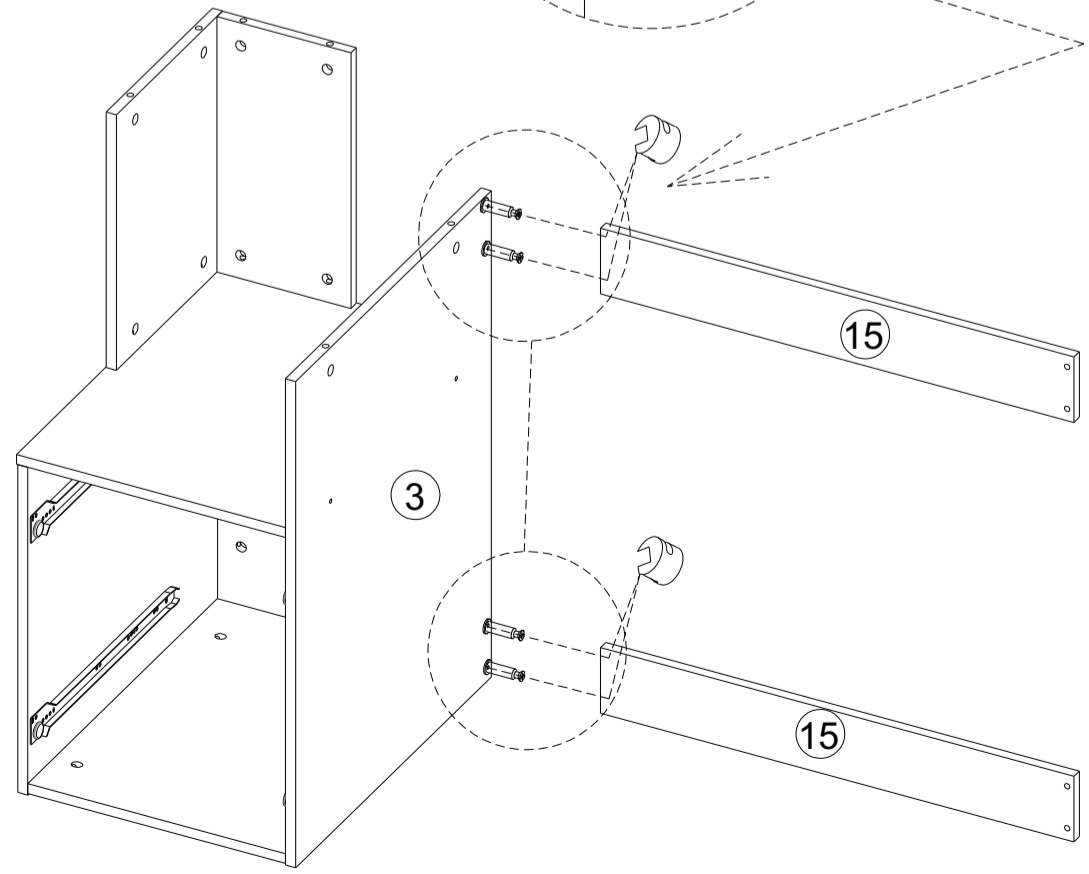
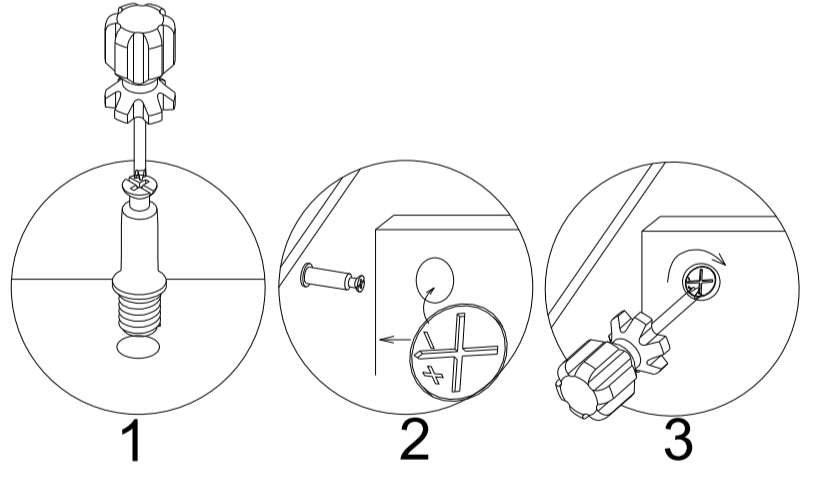
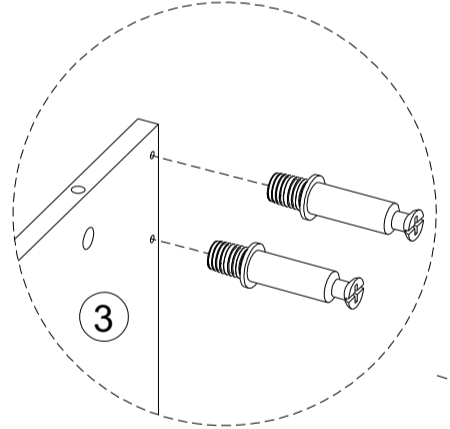

6

.SCREWS

B M5X45  
6 PCS

7

.SCREWS

B M5X45  
6 PCS

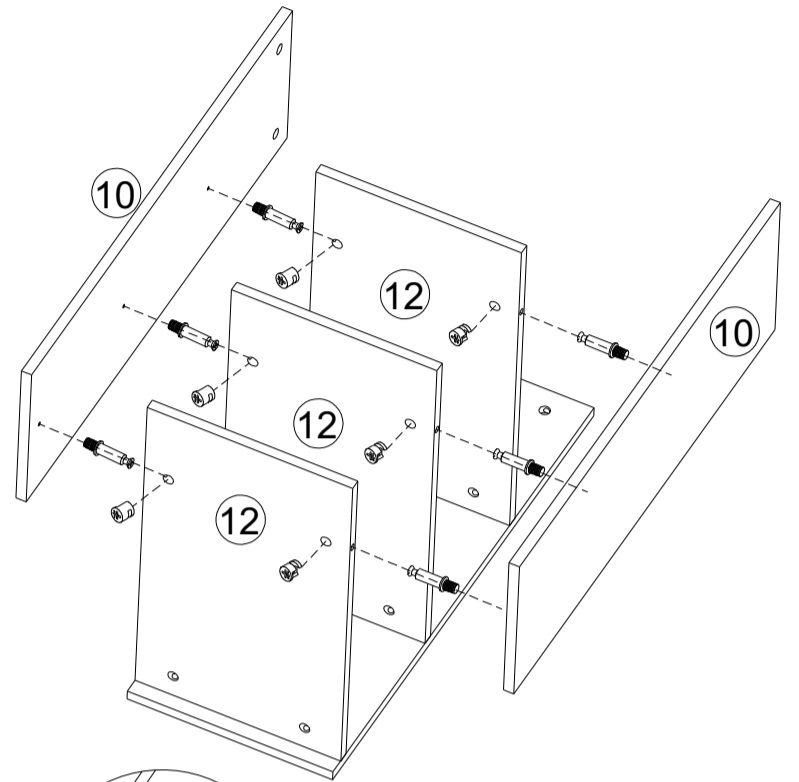
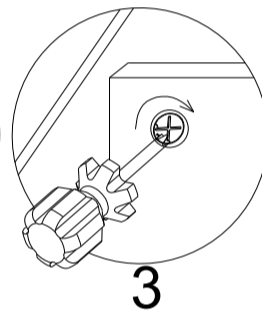
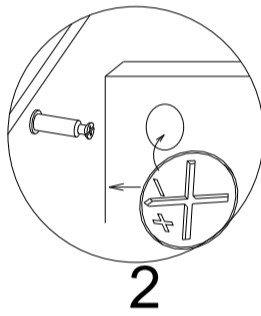
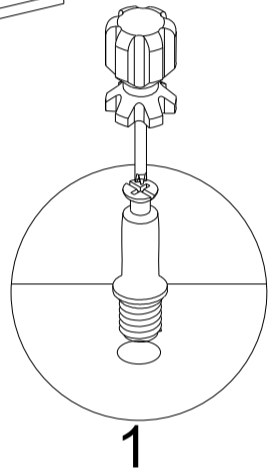
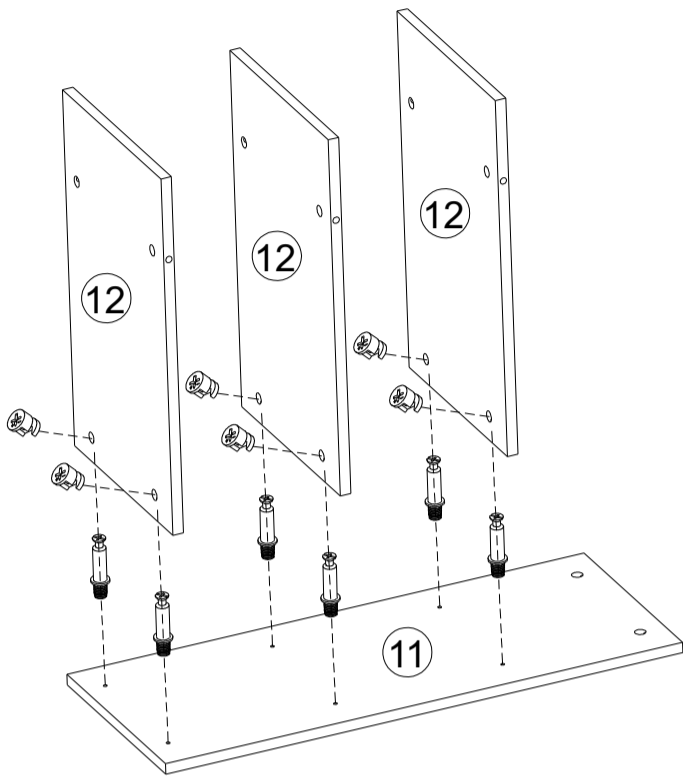

8

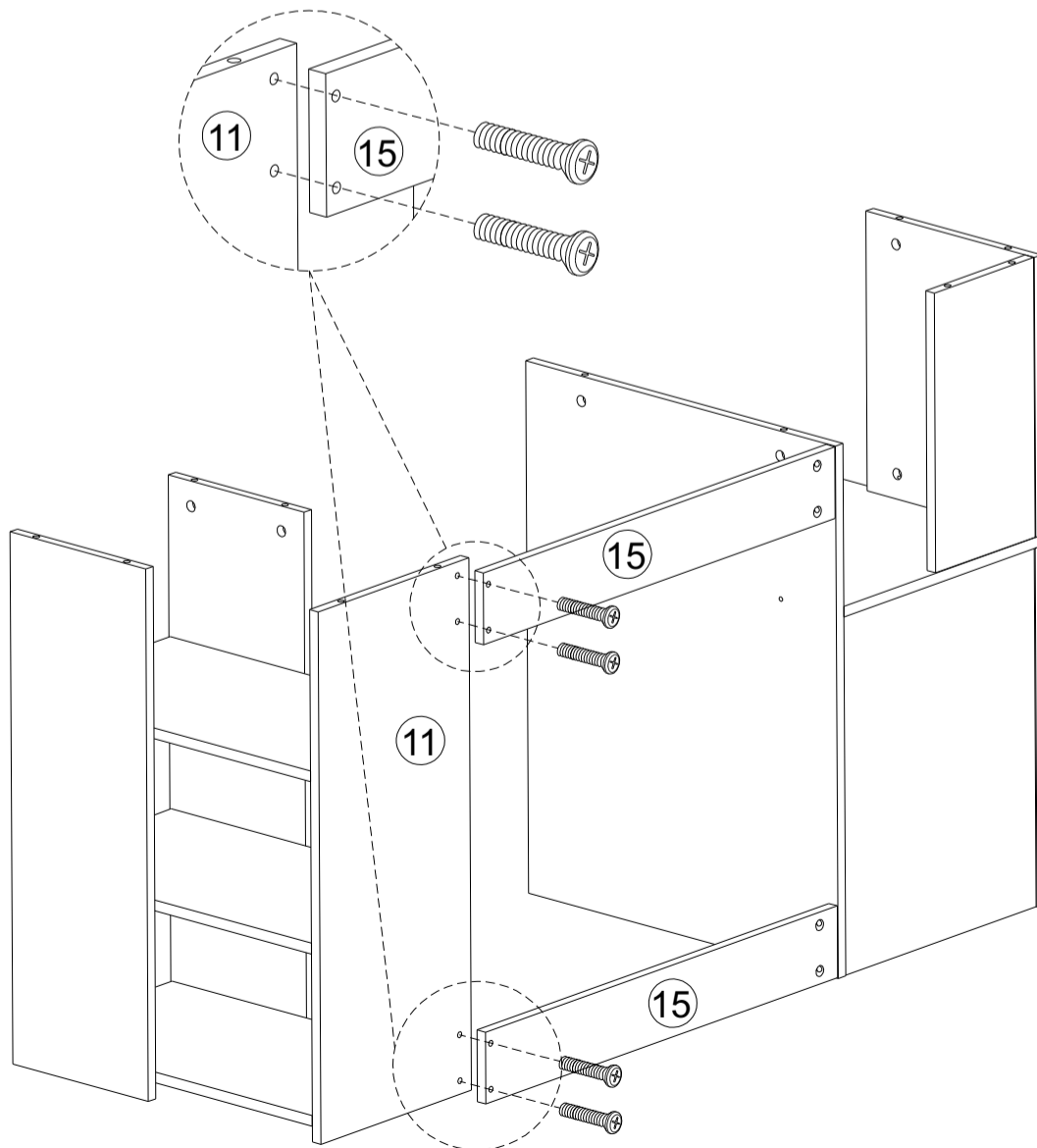

.SCREWS

D M6X25  
4 PCS

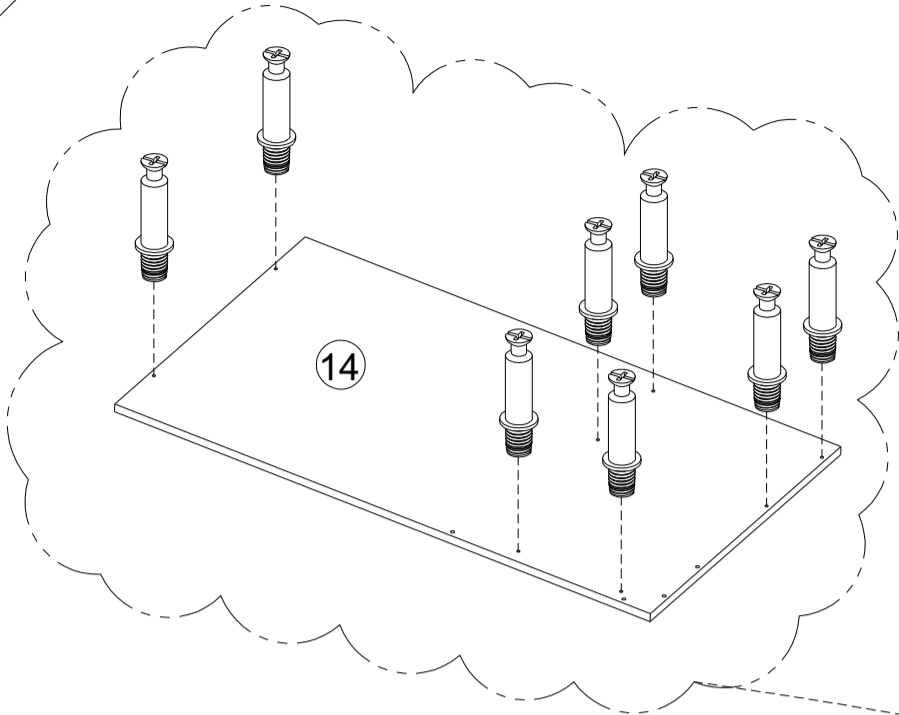

9

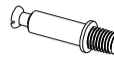

**.SCREWS**  
**B**  **M5X45**  
 **8 PCS** 

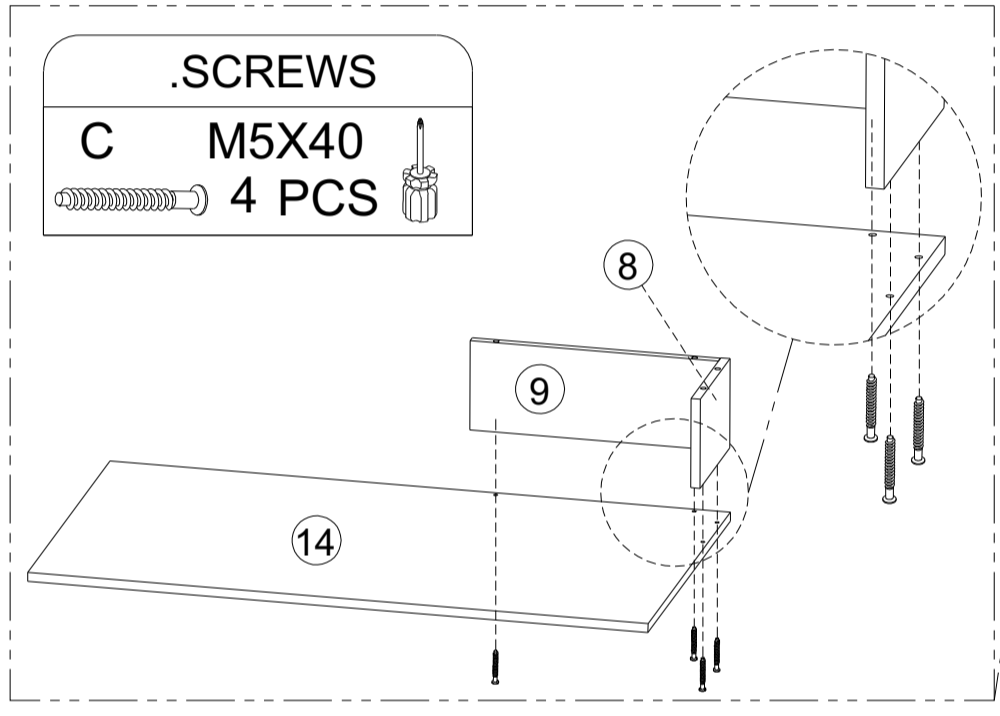
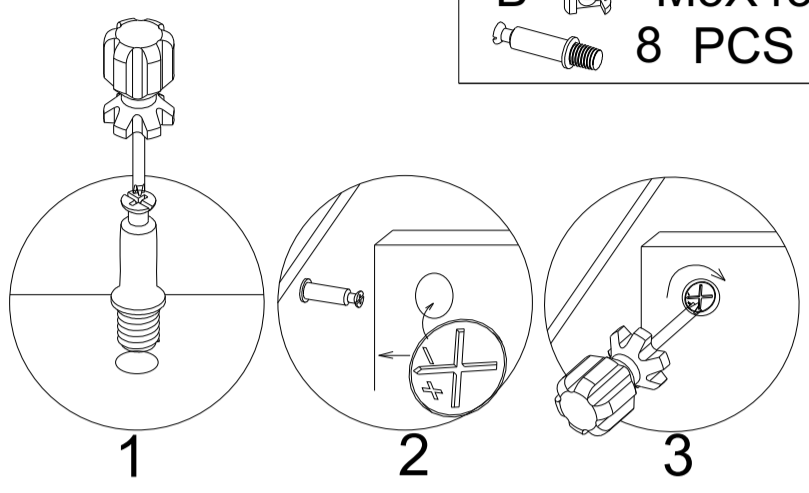

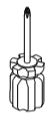
**.SCREWS**  
**C**  **M5X40**  
**4 PCS** 

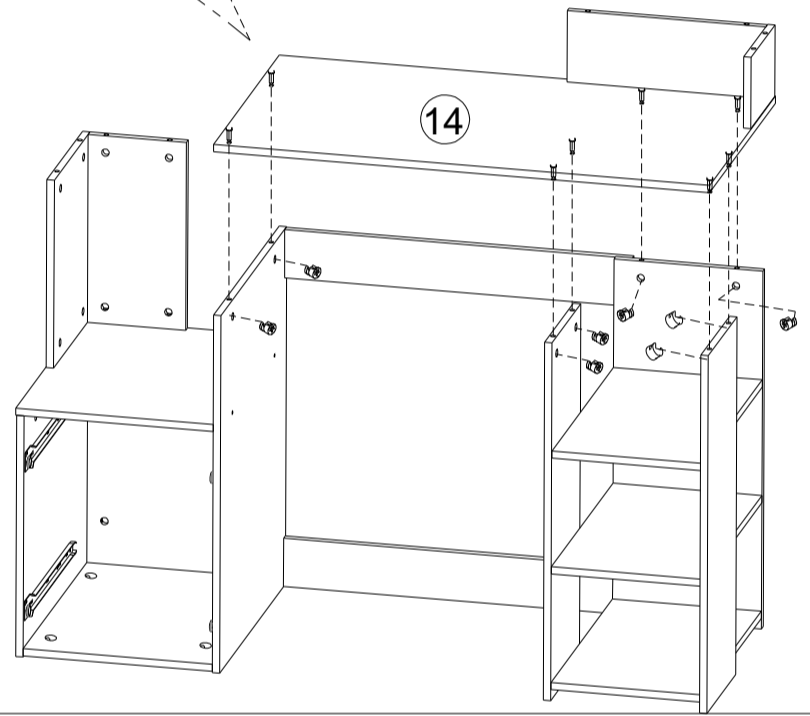

10

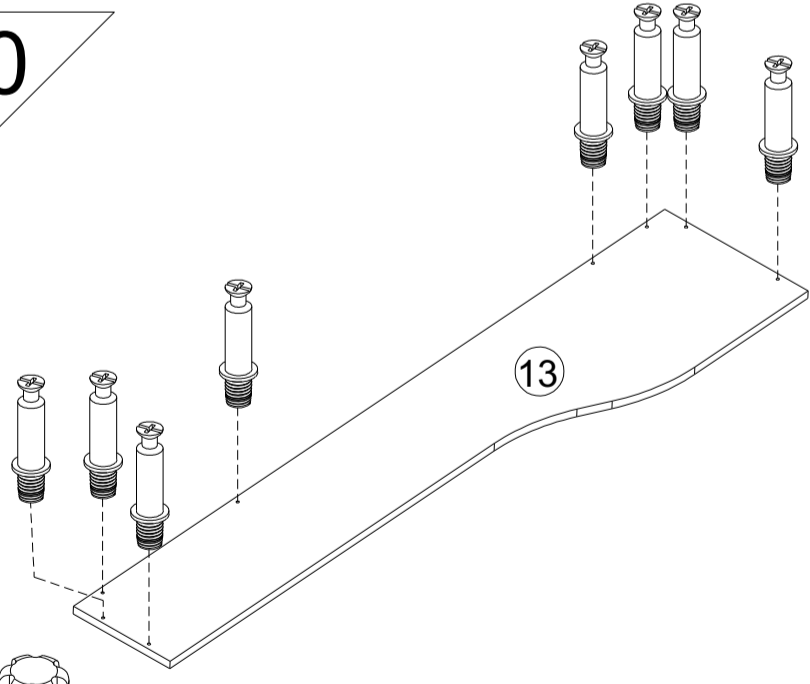

**.SCREWS**  
**B**  **M5X45**  
 **8 PCS** 

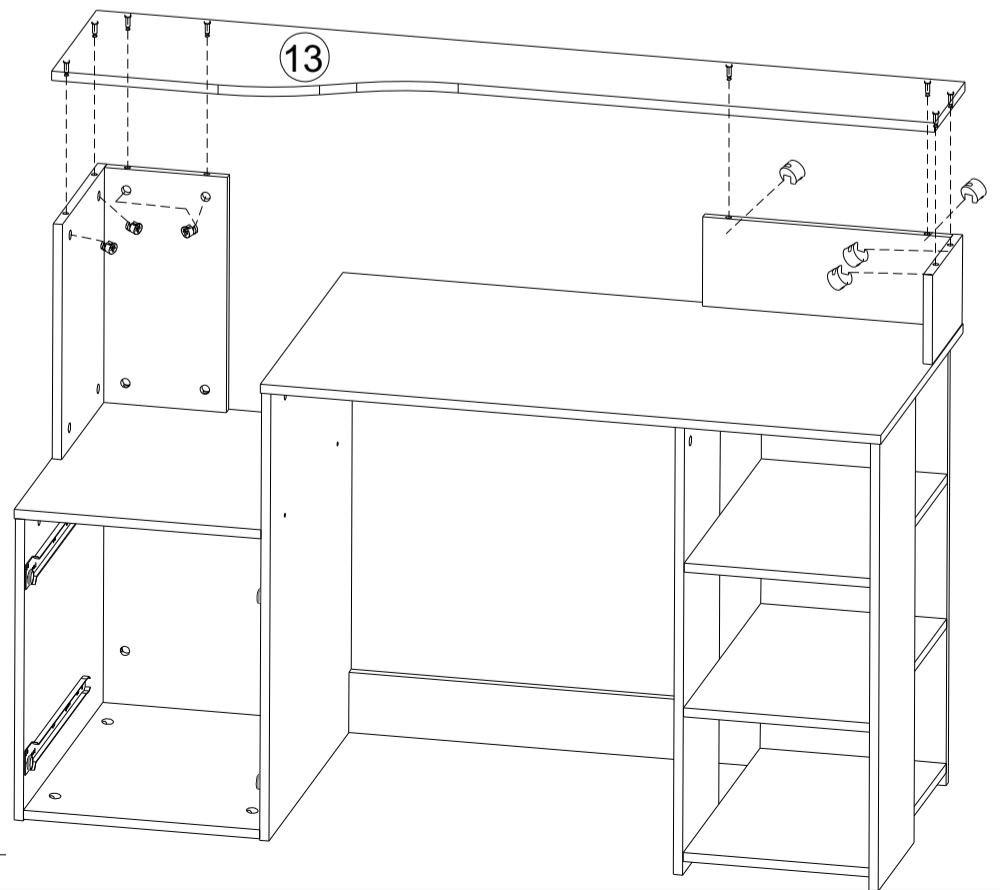
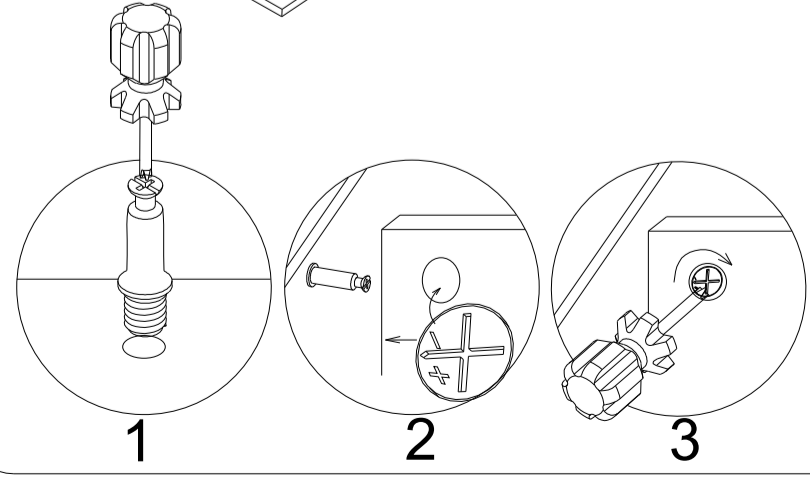

11

.SCREWS

C M5X40

4 PCS

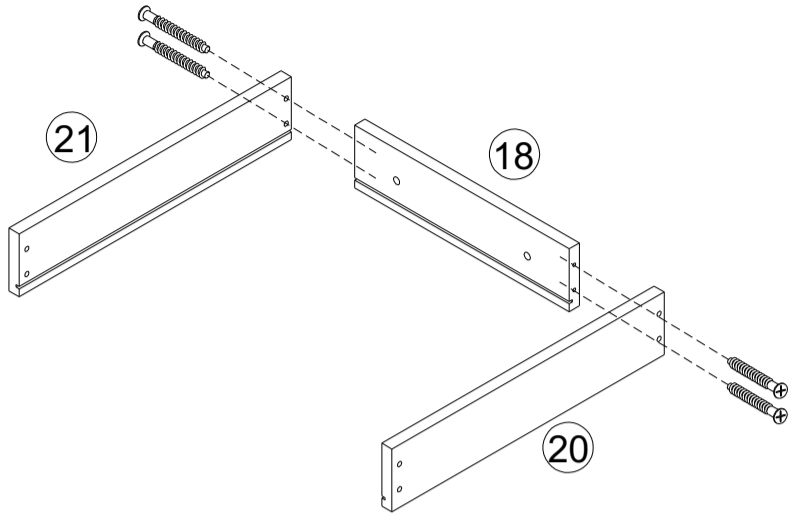

12

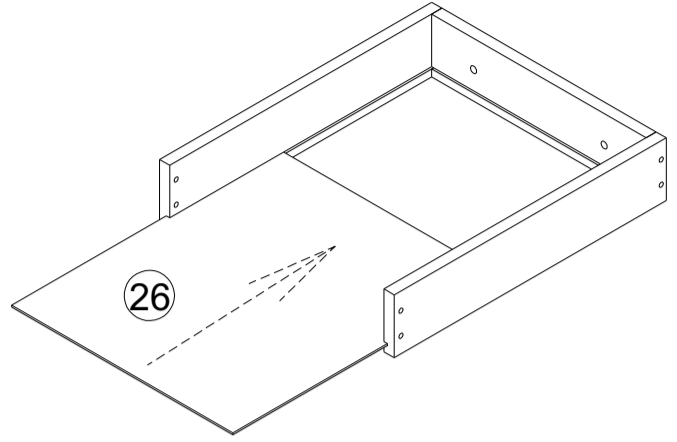

13

.SCREWS

C M5X40

4 PCS

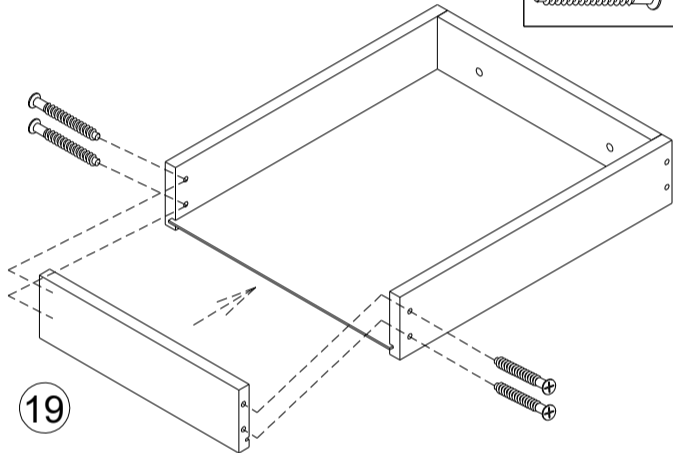

14

.SCREWS

E M4X18

2 PCS

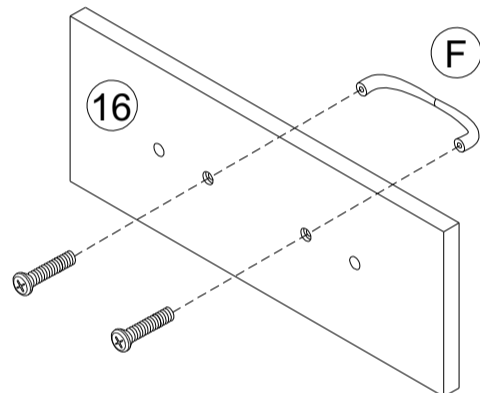

15

.SCREWS

D M6X25

2 PCS

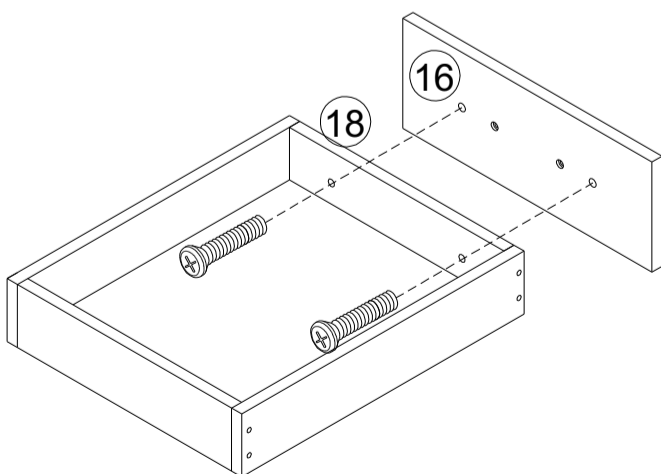

16

.SCREWS

A M3.5X14

4 PCS

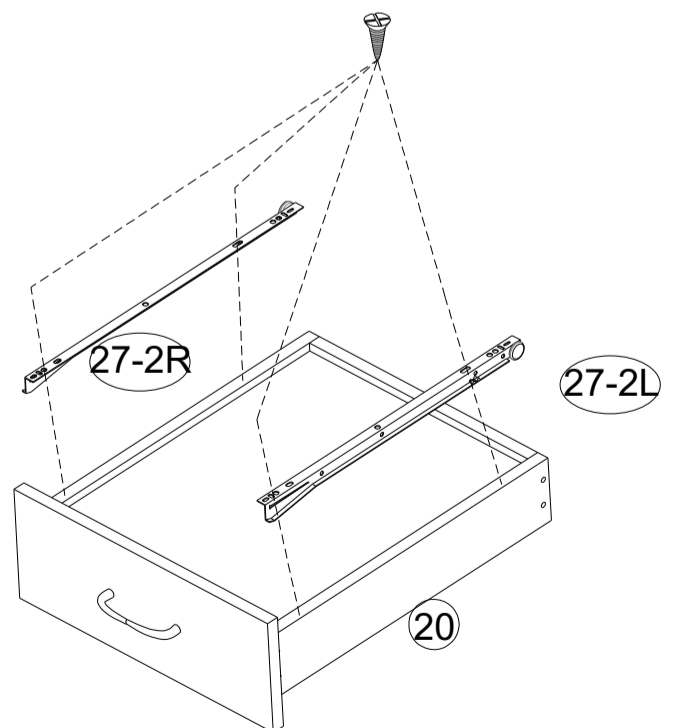

17

.SCREWS  
C M5X40  
4 PCS

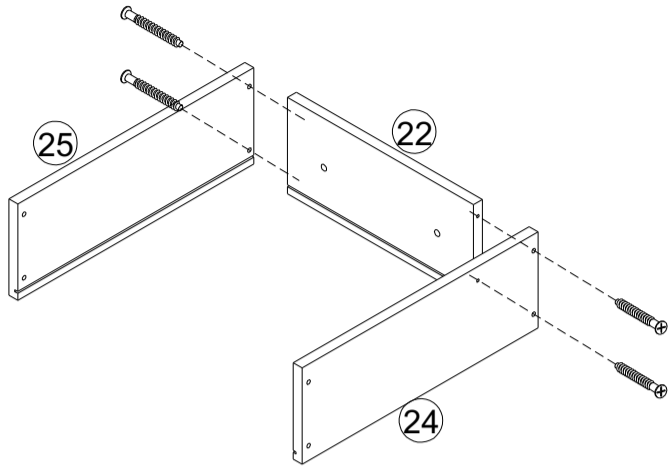

18

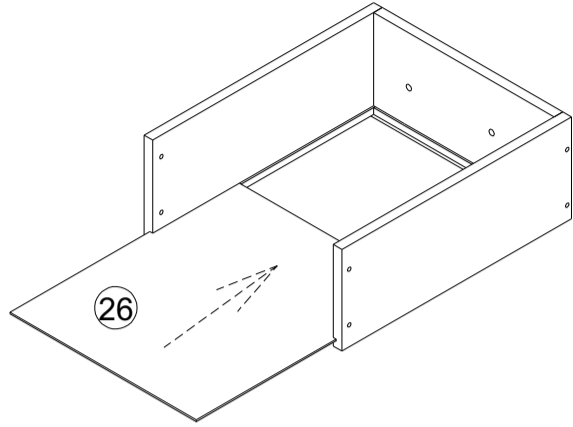

19

.SCREWS  
C M5X40  
4 PCS

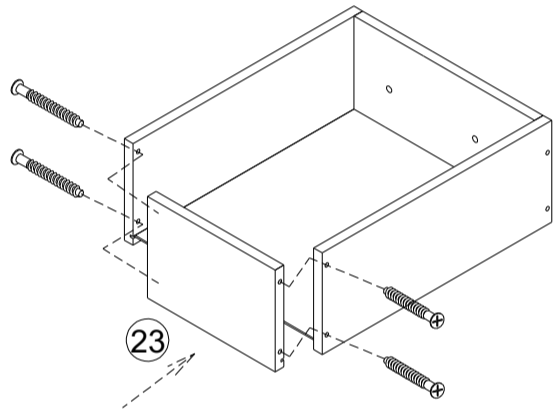

20

.SCREWS

E M4X18  
2 PCS

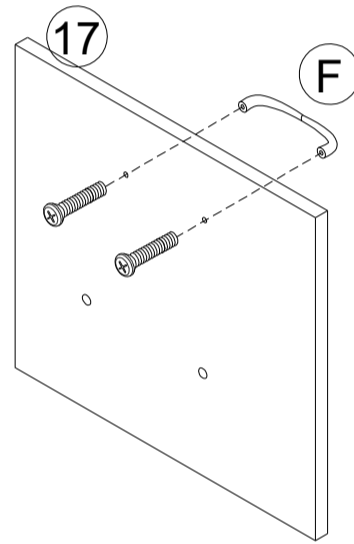

21

.SCREWS  
D M6X25  
2 PCS

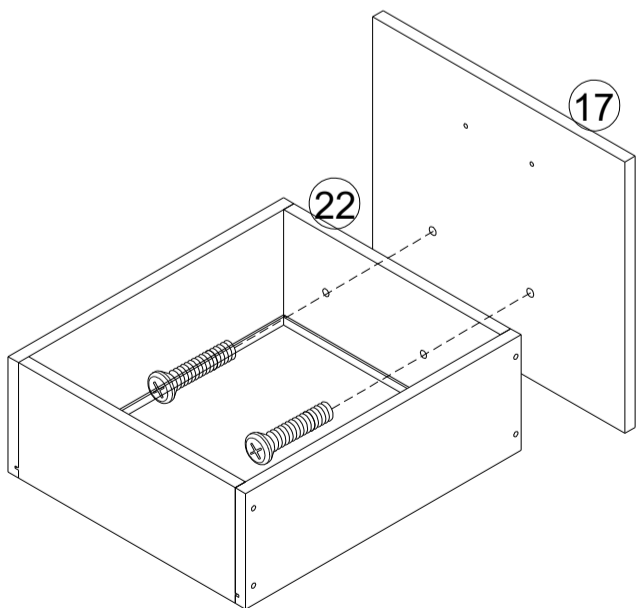

22

.SCREWS

A M3.5X14  
4 PCS

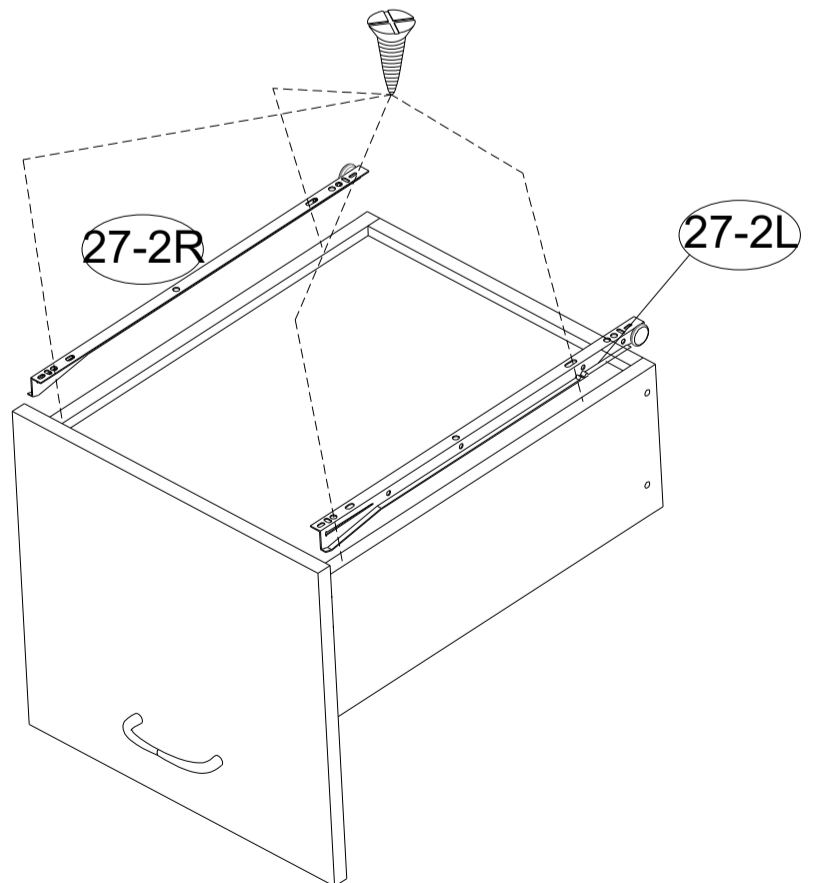

23

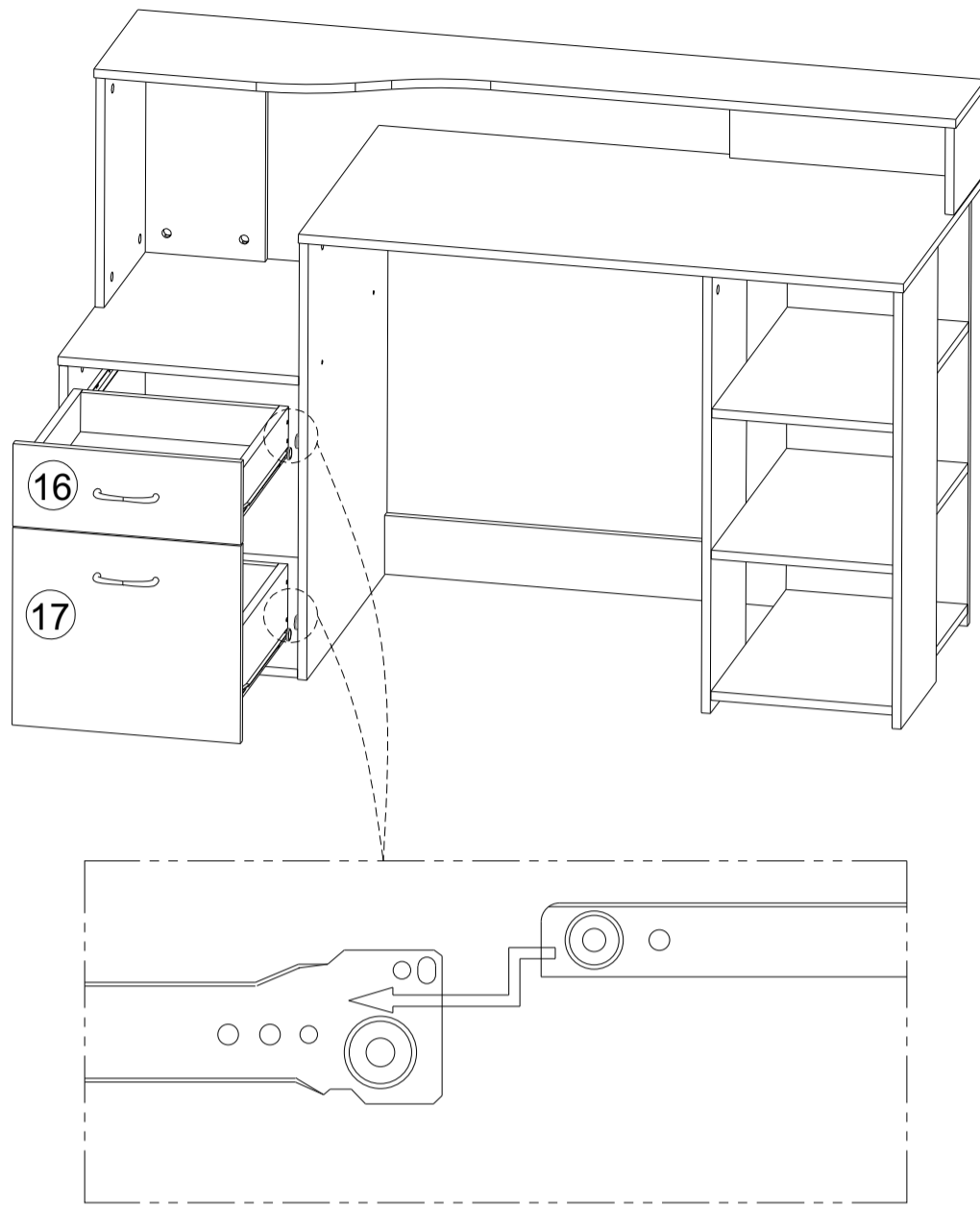

24

