Assembly Instructions

TO BEGIN

- Remove all packaging, taking care not to damage your new bed, and dispose of it carefully.
- Turn the base upside down and insert the feet/castors into the holes at each corner.
- Use a hammer to gently knock them into the holes until they click into place (if you have difficulty doing this insert a small screwdriver into the locator hole to clear the blockage).

REMOVING FABRIC DRAWER STRAPS

Fabric drawer retraining straps ensure that your drawers do not slide open during transit. They are stapled on the inside of the divan base. To remove them without damaging your divan base, please follow these instructions:-

- Cut the fabric strap across its centre to release the drawer.
- Cut the remaining fabric strap to the desired length so it is not in the way when opening and closing the drawer.

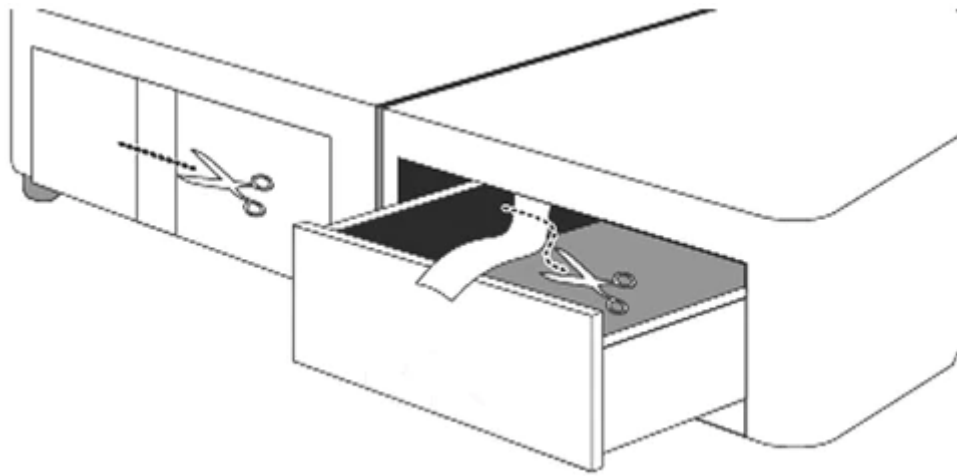

TWO PART DIVAN BASES

If your bed base is in two parts, connect them together using the appropriate procedure for your base type as detailed below.

DIVAN BASE WITH U-CLIPS

- After fitting the feet/castors, turn both parts of the divan on their side and bring them together so that the two flat ends meet.
- Where the ends meet, fit the U-CLIPS so that they clamp around the underside timber edges to hold the two parts firmly together.
- After fitting the U-CLIPS lower the divan down so that it is right way up ready for the mattress to be placed on top.

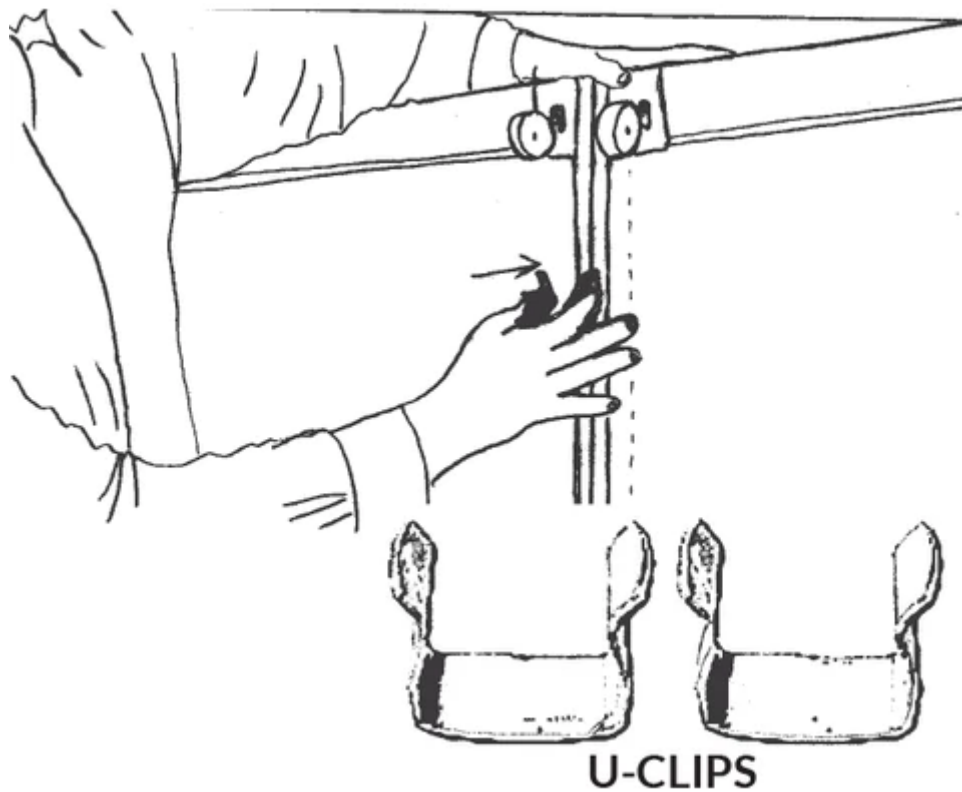

DIVAN BASE WITH LINK BARS

If your divan base is in two parts which connect together in this way it will have come supplied with two LINK BARS and four bolts.

- After fitting the feet/castors, turn the two parts of the divan base the right way up and bring them together so that the two flat ends meet.
- On each side, close to where the two parts meet, you will find pre-drilled threaded bolt holes. Connect the bases together by passing the bolts through the slots in the link bars and screwing them by hand into the threaded holes.
- After checking that the two parts of the base are firmly together, tighten the links bars into position.

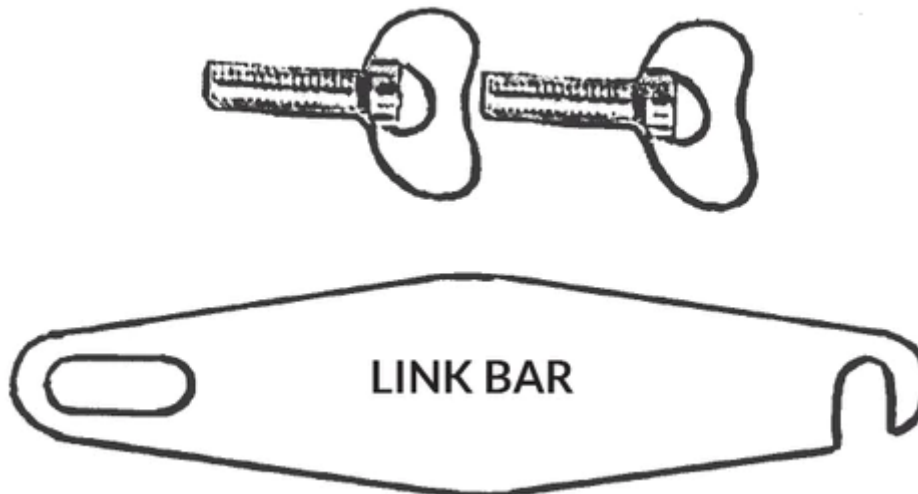

OTTOMAN DIVAN BASE

We recommend for two people to complete the following assembly instructions as the ottoman is a heavy product.

- After fitting the feet/castors, turn the two parts of the divan base the right way up and bring them together so that the two flat ends meet.
- Insert the U-clips provided and tighten to create a snug fit.
- Link the two lids together using the bolt provided to connect the two lids together as one.
- To attach your headboard first pierce the material at the locator bolts. Place the headboard up to the base, remembering to use the spacer between the headboard and base. Insert the long bolts and tighten.
- Place your mattress on the Ottoman whilst it's in the open position.
- The unit is designed to operate with a mattress in place. Initially the gas struts may feel stiff when opening and closing the Ottoman; this is perfectly normal and movement will become easier after operating the unit several times.

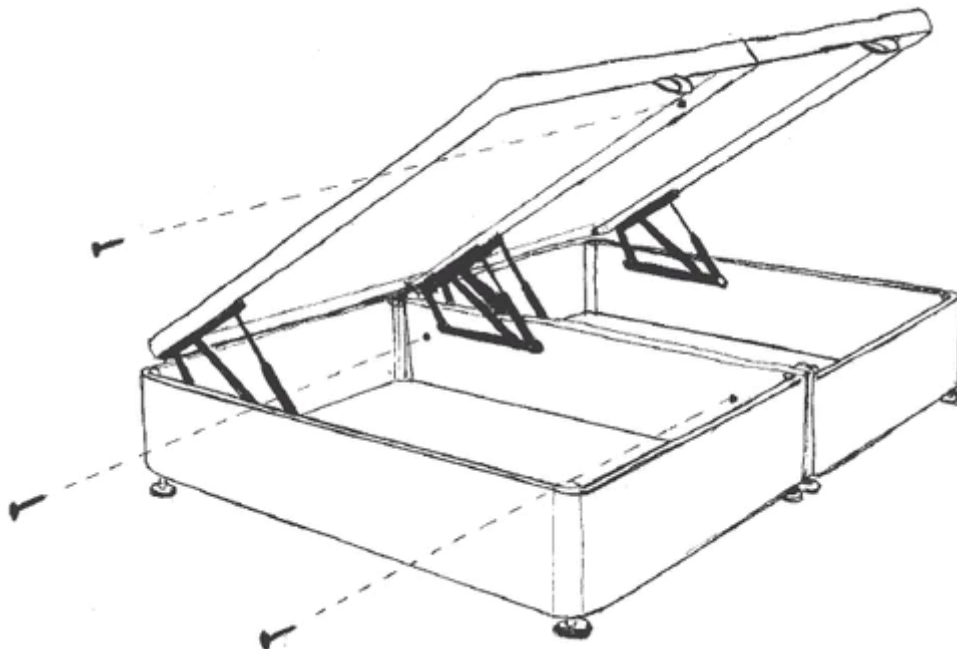

FIXING A HEADBOARD TO A DIVAN BASE

- The two wooden struts are attached to the back of the headboard by a single screw in each. Loosen the two screws and rotate the struts so they are vertical.
- With the two extra screws supplied fasten the struts in position. Note that there are four holes in each strut to allow two height positions of the headboard.
- The headboard can now be fastened to the divan with the large headed screws supplied by the bed manufacturer.
- The height of the headboard can be adjusted by moving it up or down on the slots. Tighten the screws to the desired position.

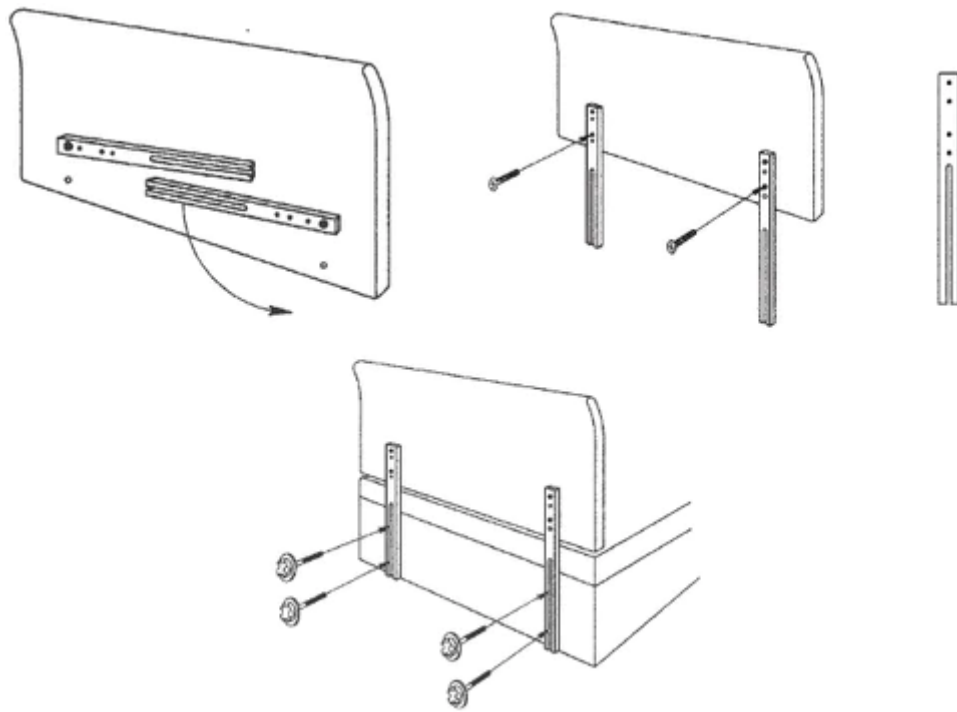

IF YOU HAVE PURCHASED A MATTRESS ONLY

- Do not use a mattress on a base for which it was not designed. The best base for a mattress is a divan.
- If you are using a slatted base, we recommend spacing no greater than 63mm (2½") between slats in order to avoid damage to the mattress.
- Do not use a solid plywood or hardwood base or place these materials under the mattress as condensation may build up through lack of ventilation, causing mould or deterioration on the underside of the mattress.
- The life of a mattress can be severely shortened by using it with an unsuitable base.

AIRING A NEW MATTRESS

After removing the polythene packaging allow the mattress to breathe for four hours before fitting your bedding. This will allow any moisture, which may have been trapped by the packaging, to evaporate. Your new bed may have an aroma of 'newness' or, if it contains memory foam, a slight "chemical" smell, this is perfectly normal and will soon fade after airing.

CARING FOR YOUR BED

- A double-sided mattress must be turned over regularly. This ensures even settlement of the fillings and will prolong the life of the mattress by making sure

your body weight is applied evenly all over. A double-sided mattress should be turned over once every week in the first 3 months after it was purchased and monthly thereafter.

- A “Non Turn” mattress should be rotated 180° head to foot once every week in the first 3 months and monthly thereafter.
- Over time your body will create a shallow impression in the surface of the mattress; this is perfectly normal and is due to settlement of the fillings. Regularly turning the mattress will minimise this effect.
- Remove the sheets and covers on a regular basis to allow air to get to your mattress. Air circulating through the fabric and fillings will help to keep it fresh and odour free.
- Using a mattress protector will help to guard against accidental damage to the mattress, protecting against dirt and stains, wear and tear and will help to keep your mattress looking new.
- Your new bed will feel different to your old bed and you should allow some time for your body to adjust to the feel of it.

DO NOT

- Do not bend, fold or roll your mattress - this will cause serious damage to the fillings, internal spring unit and wire frame.
- Do not jump or stand on your bed, this can cause damage. Do not allow children to use it as a trampoline!
- Do not sit on the edge for prolonged periods to avoid distorting the springs.
- Do not place heavy objects on the mattress, it is designed only to support your body weight, evenly distributed across the surface.
- If your divan base has drawers do not overload them, they are designed to hold lightweight items only.
- Do not use chemical or detergent cleaners as these may adversely affect the fabric and fillings. In the event of soiling, lightly sponge the affected area with a weak solution of soap and water. Avoid over wetting
- Do not vacuum the mattress as this can disturb the fillings. Lightly brush with a soft brush to remove dust and fluff.
- Do not move the bed by the headboard as this may cause damage to both the base and the headboard.

ENJOY YOUR NEW BED!
