

SICOTAS

Prelude Dresser with 7-Drawers

DR130A1XBNY1864 | DR130A1XLTY1865

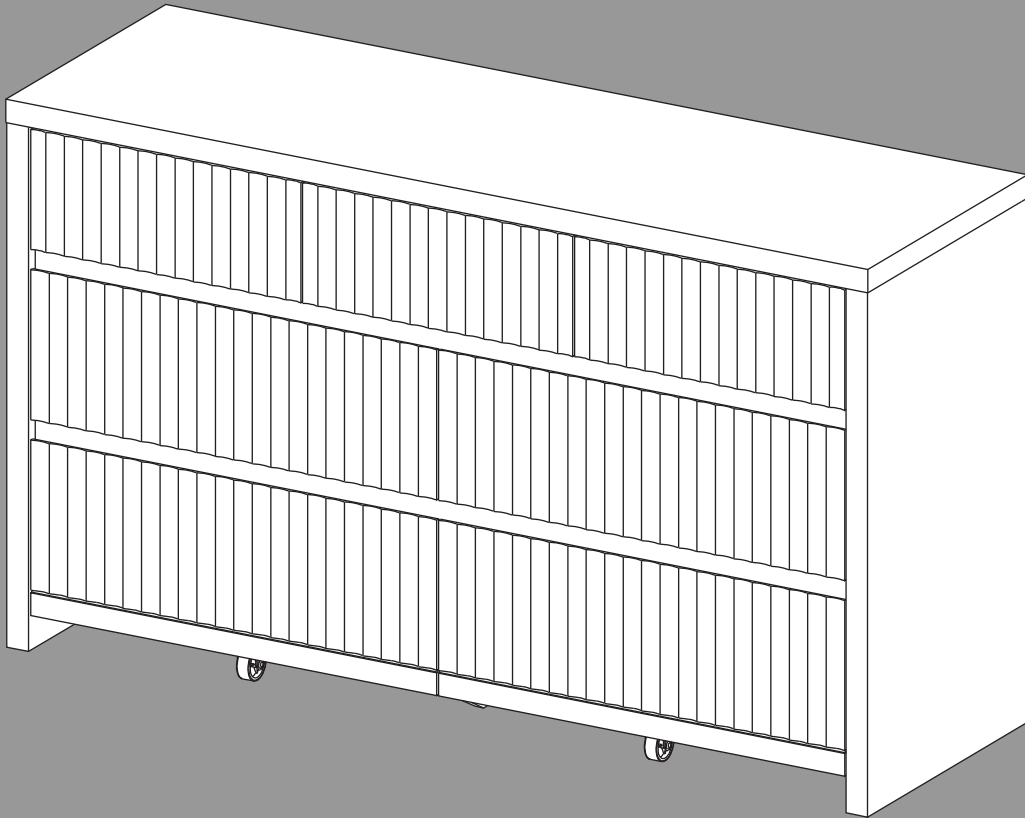

Prelude Collections

Assembly Instructions

Before beginning the assembly process, please read and save these instructions for reference. Following these guidelines will ensure a smooth and successful assembly of your product.

1. Part Identification:

Carefully separate and identify all the parts included in your package. Confirm that you have all the components listed in the instruction manual. This step will help you avoid any missing or misplaced parts during assembly.

2. Work Surface:

To prevent any scratches or damage to the product, assemble it on a soft mat or a similar protective surface. This will provide a cushioned area for the components and protect the surfaces from unwanted marks.

3. Step-by-Step Assembly:

Follow the assembly instructions provided, proceeding one step at a time. Take care to understand each step properly before proceeding to the next one. This sequential approach ensures that the assembly is done correctly and minimizes the chance of errors.

4. Proper Screw Seating:

When attaching screws and nuts, it is essential not to fully tighten them until all screws are correctly seated. By partially tightening each screw and nut initially, you can ensure that they are aligned properly and fast securely before final tightening.

5. Avoid Over-Tightening:

While each screw and nut should be tightened correctly, it is crucial not to over-tighten them. Over-tightening can cause damage to the product or compromise its structural integrity. Use the appropriate amount of force to secure the components without excessive tightening.

SICOTAS customer help center:

If you encounter any questions or problems during the assembly process, please do not hesitate to contact us.

We strive to provide excellent customer support and will respond to your inquiries within 24 hours. Our team will offer you a suitable solution to address any concerns you may have.



Email:
service@sicotas.com



Website:
www.sicotas.com



Phone:
(833) 742-6827



Official Website:



WhatsApp:



YouTube:



Instagram:



Facebook:



TikTok:

Parts List

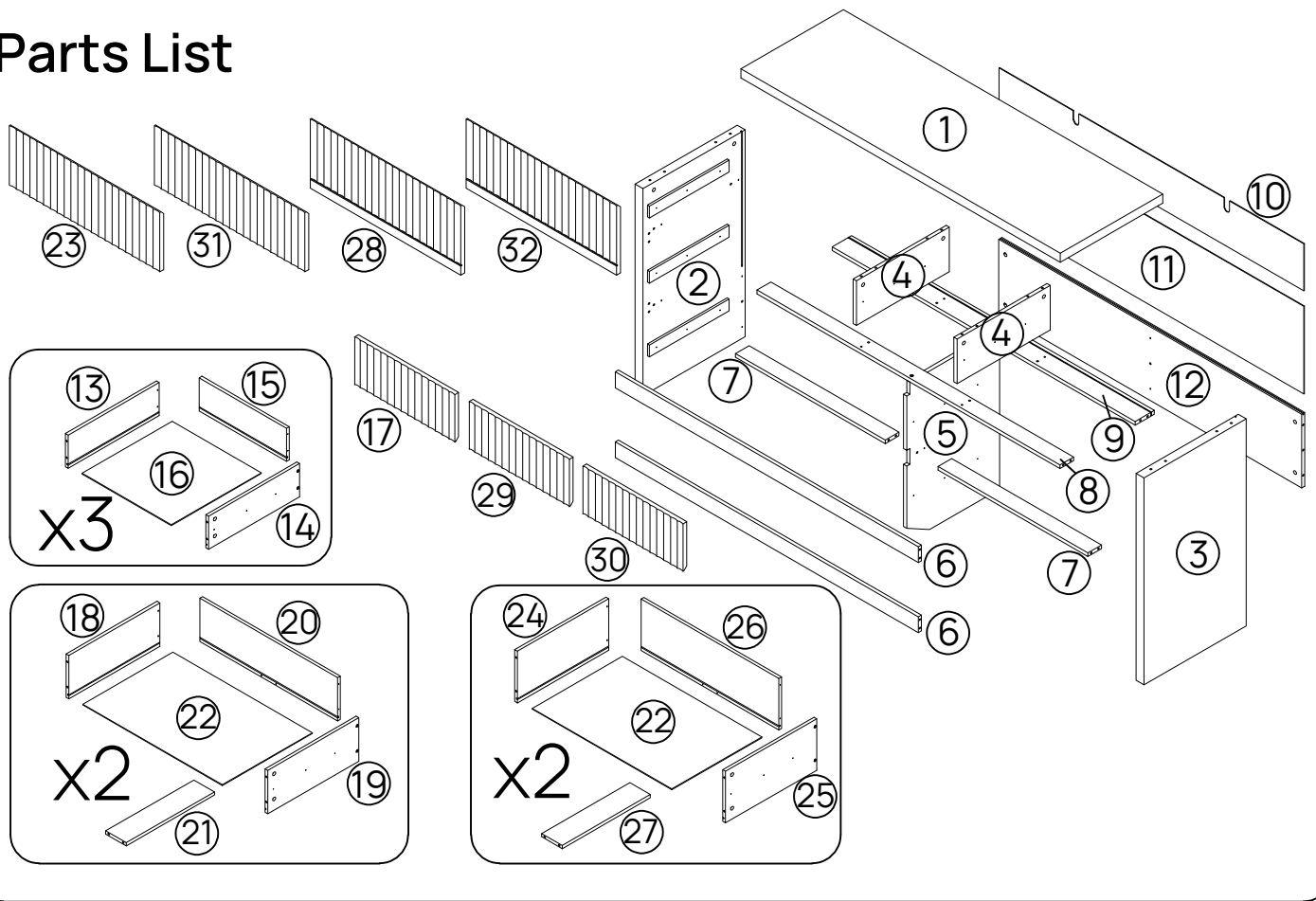

Hardware List



Code	Description	Quantity	Code	Description	Quantity
A	Cam bolt	56+2	I	M3x17mm Screw	16+2
B	Cam lock	56+2	J	Anti falling iron sheet	2
C	Wooden dowel	33+2	K	Plastic anchor	2
D	M4x38mm Screw	36+2	L	Caster	2
E	M3.5x12mm Screw	84+2	M	Drawer slides	14
F	M4x12mm Screw	10+2	N	Wrench	1
G	Ø6x50mm Bolt	8+2	O	M4x35mm Screw	2+1
H	Back clip	16+2			

Step 1

Press the plastic part in the indicated direction to separate drawer runner M1 and M2 before assembling.

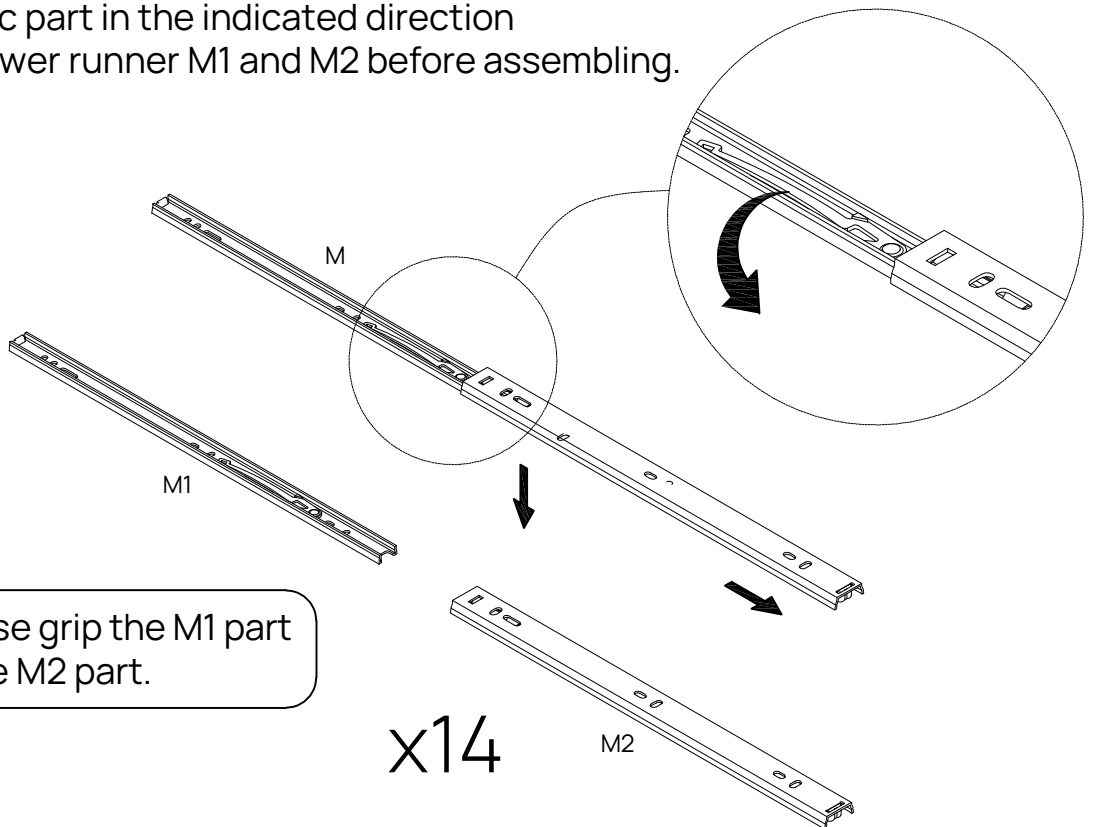

Attention: Please grip the M1 part while sliding the M2 part.

Step 2

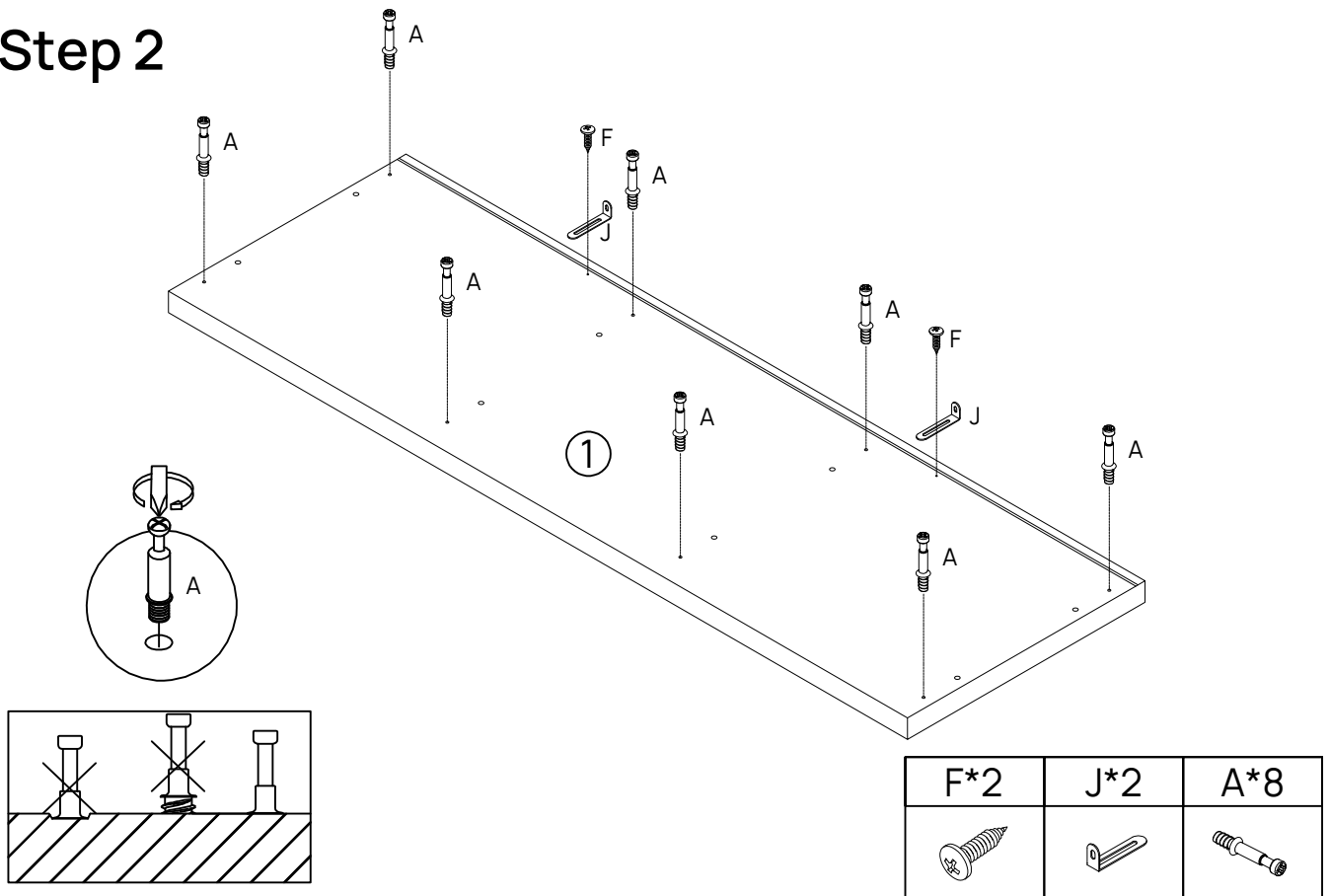

Step 3

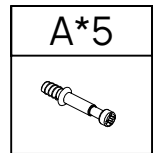
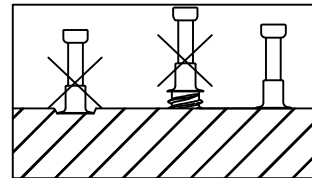
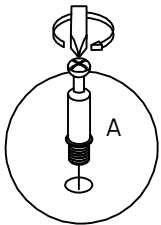
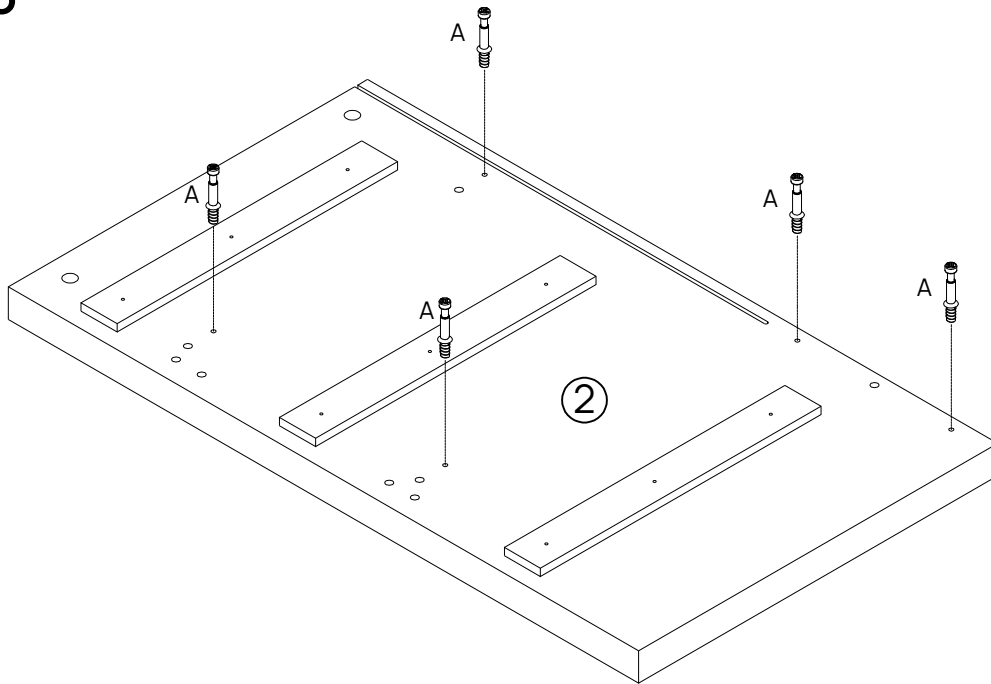

Step 4

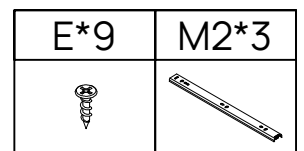
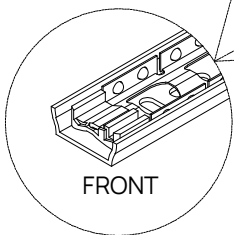
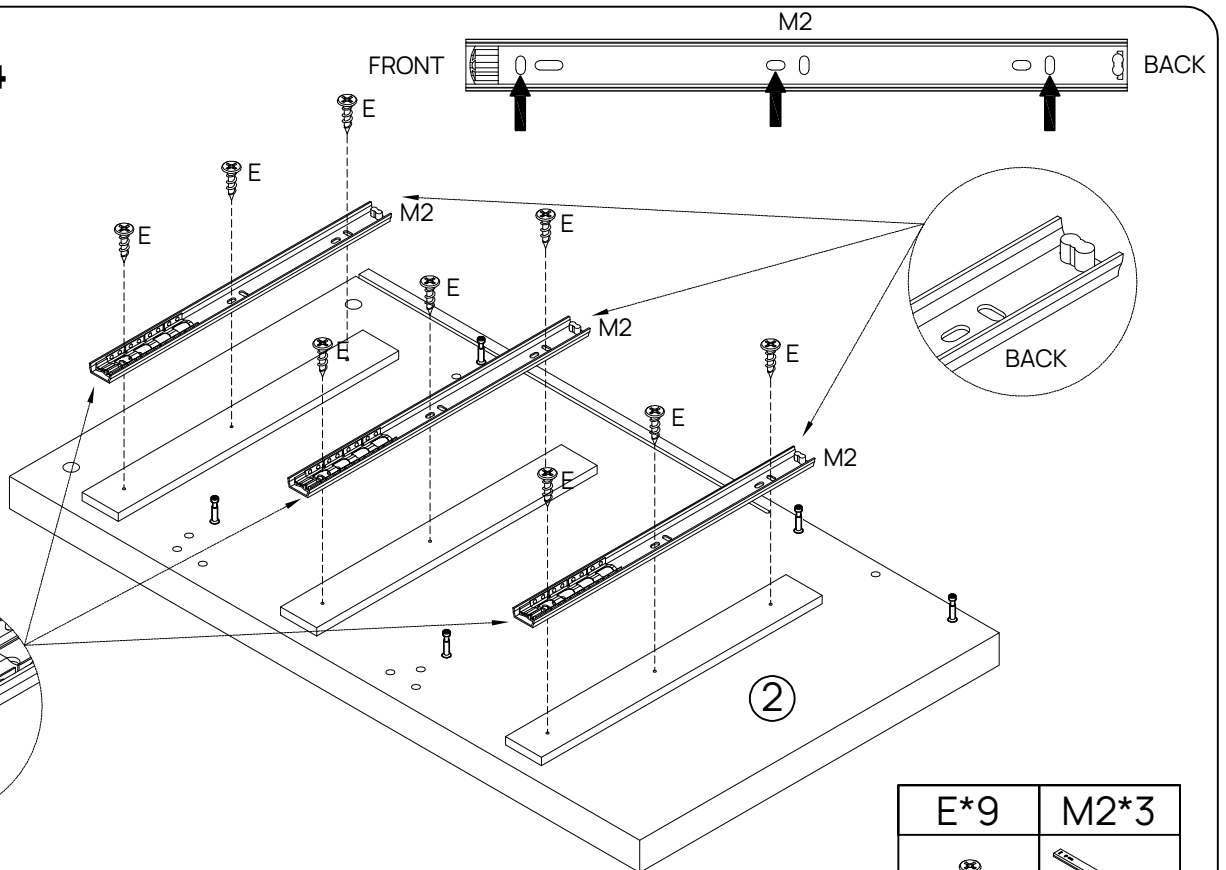

Step 5

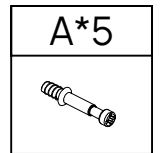
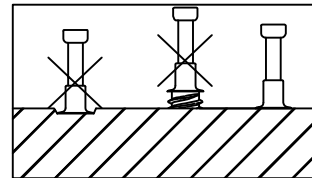
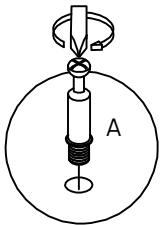
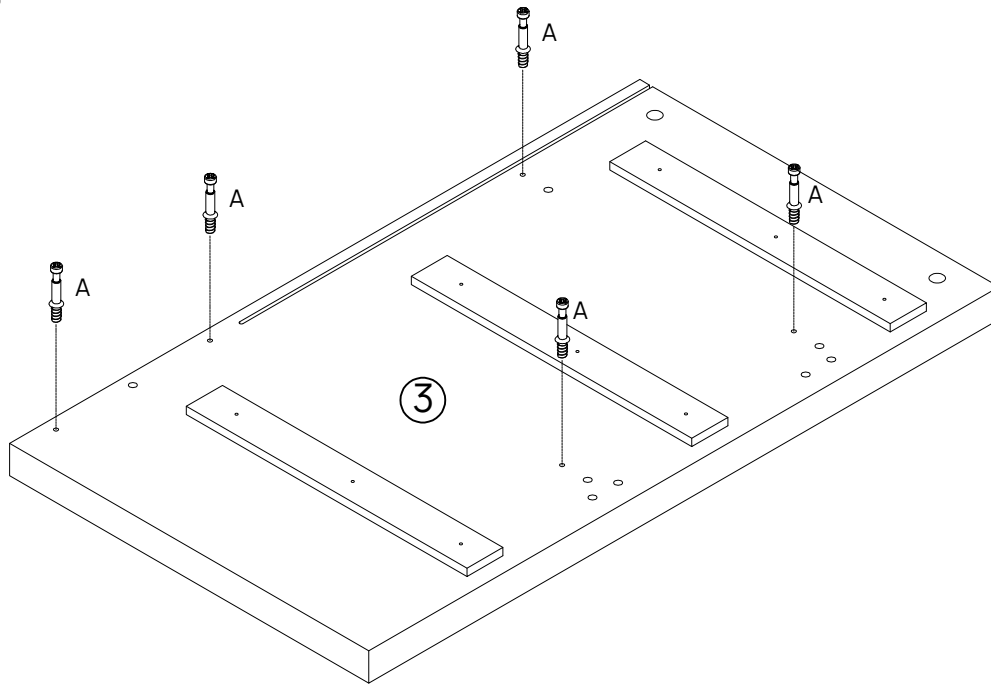

Step 6

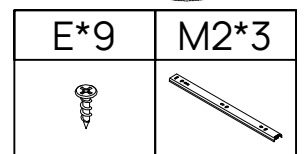
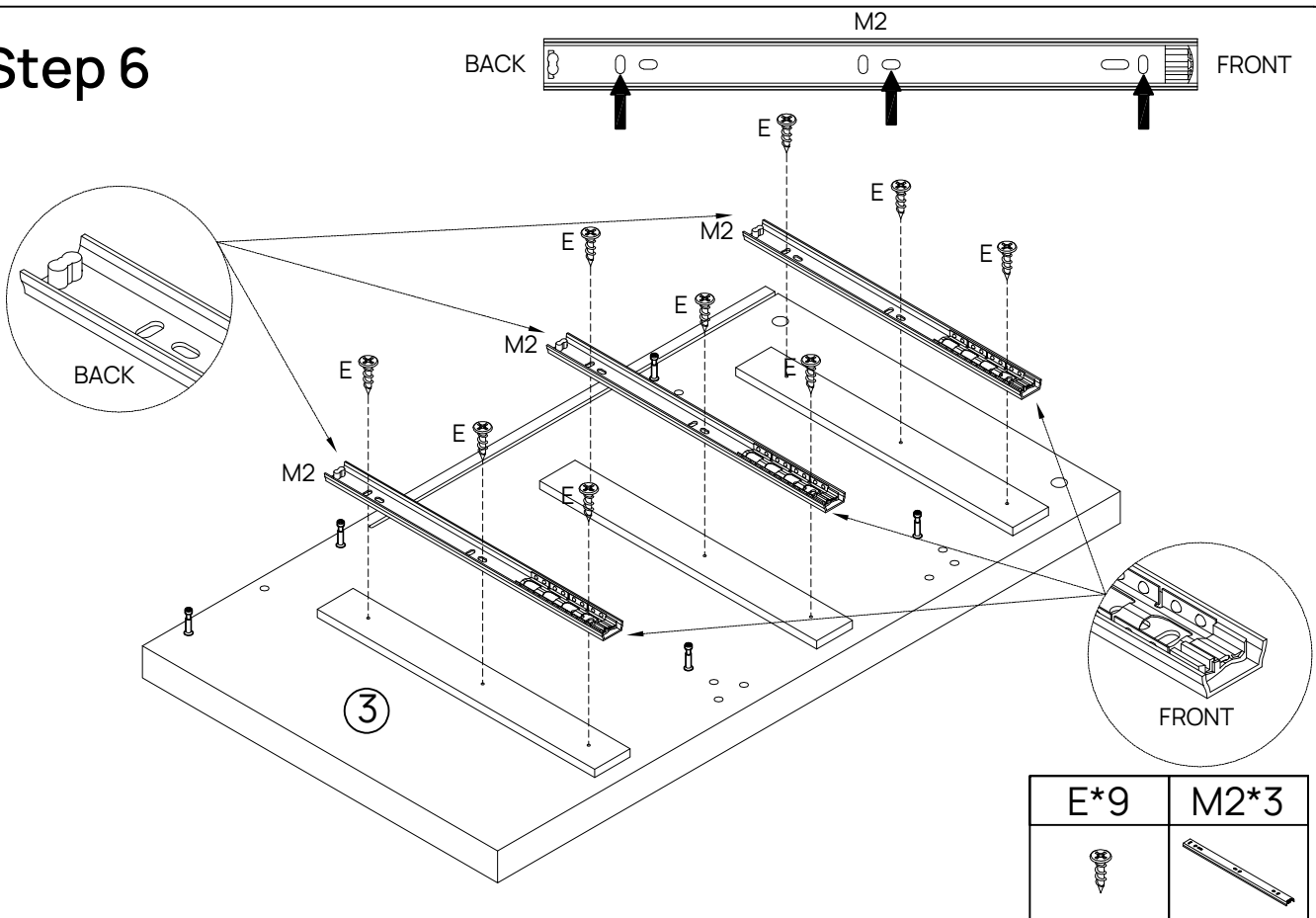

Step 7

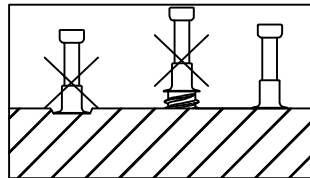
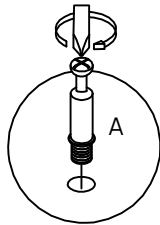
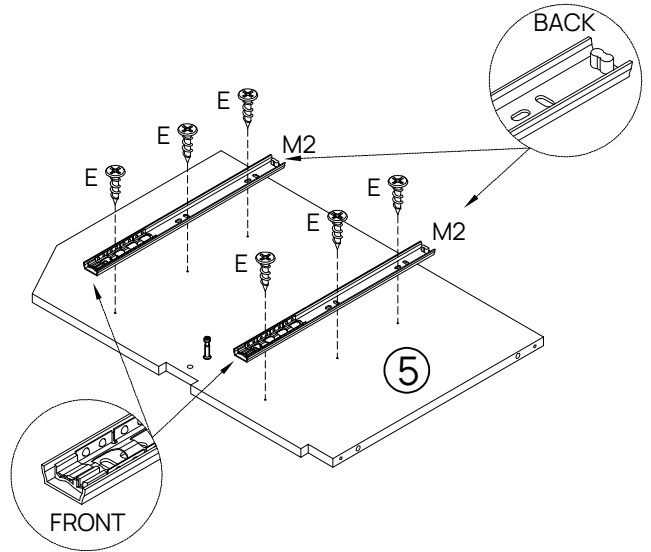
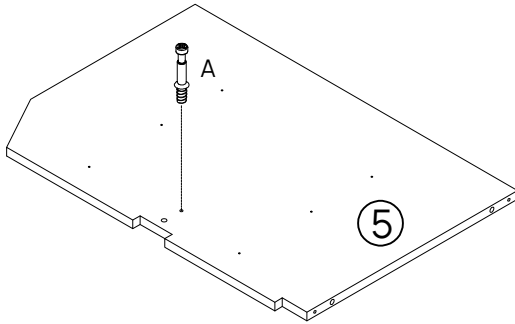
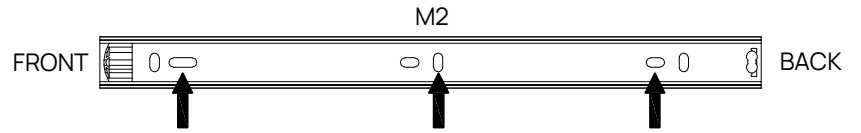

E*6	M2*2	A*1

Step 8

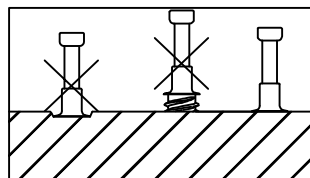
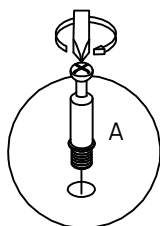
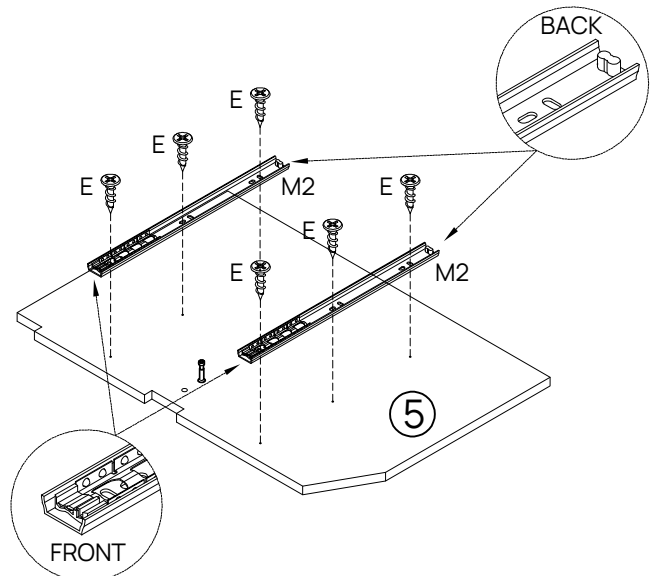
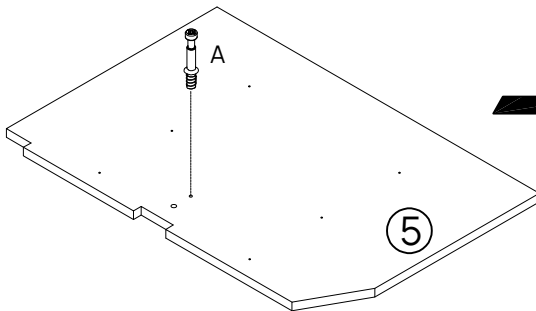
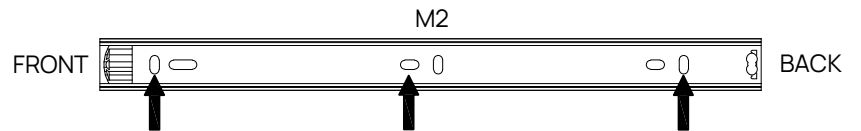

E*6	M2*2	A*1

Step 9

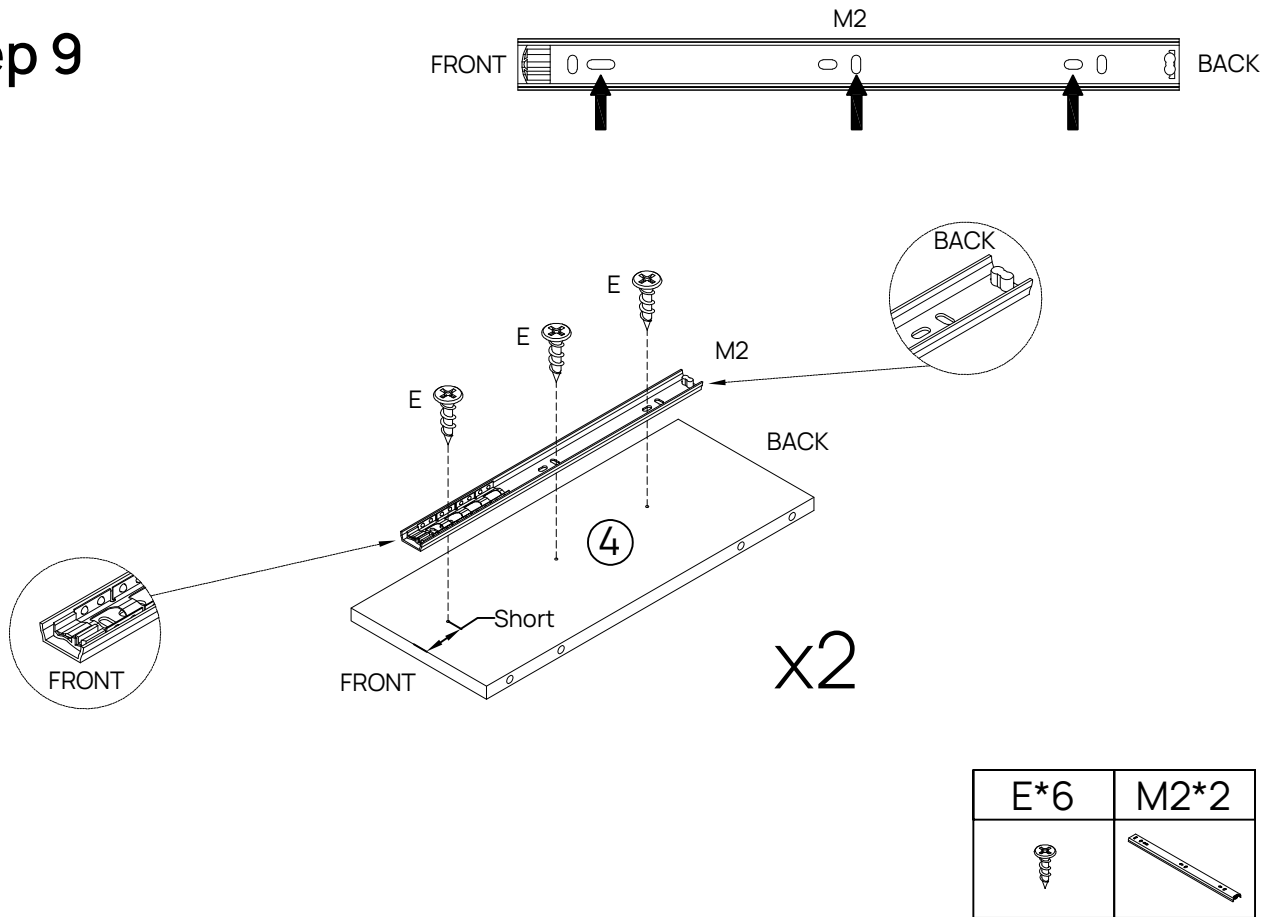

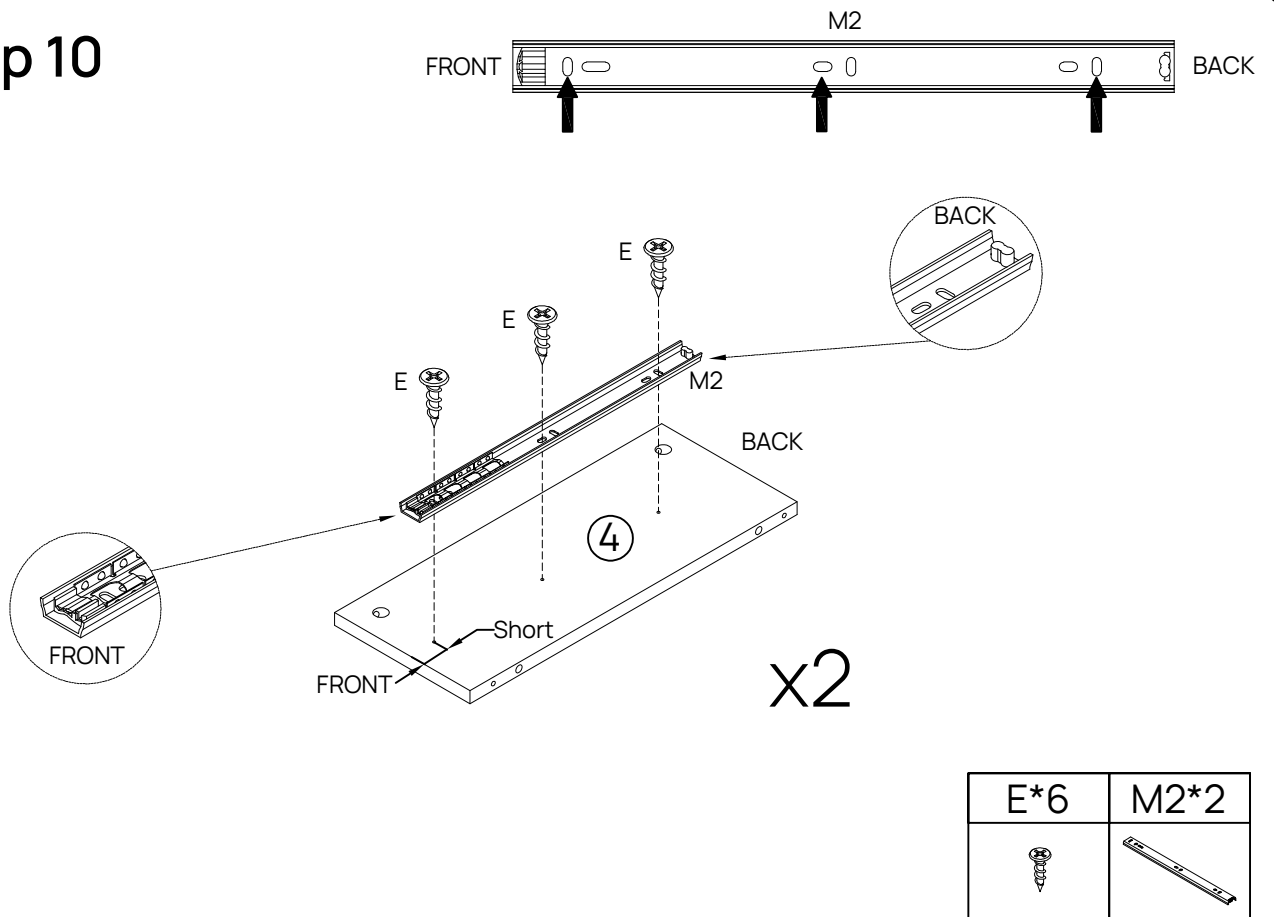

Step 10



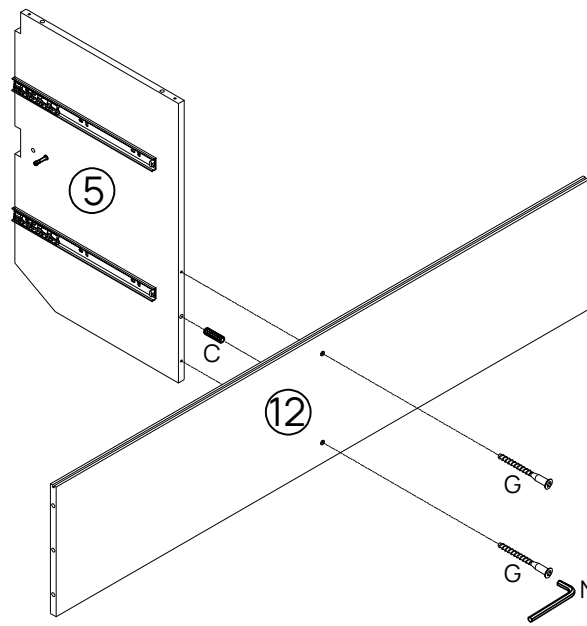



Step 11

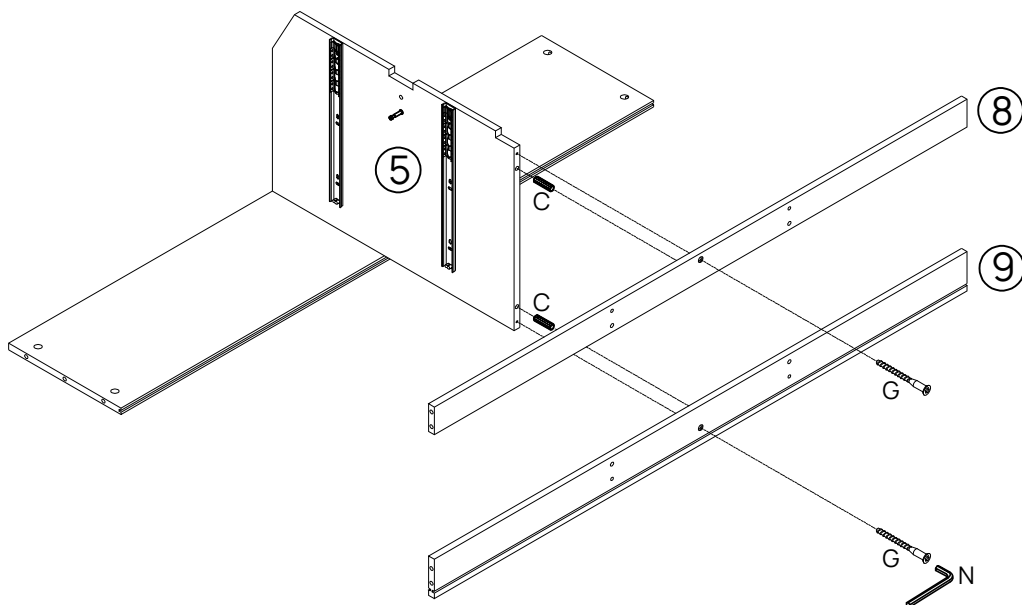

G*2	C*1	N*1
		



Step 12



G*2	C*2	N*1
		

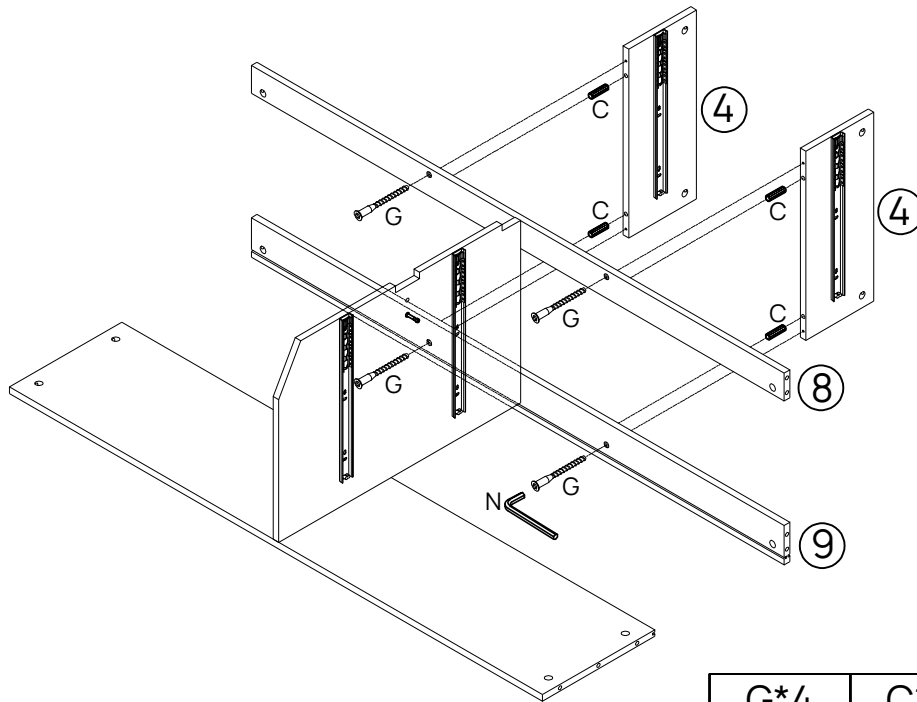

Step 13

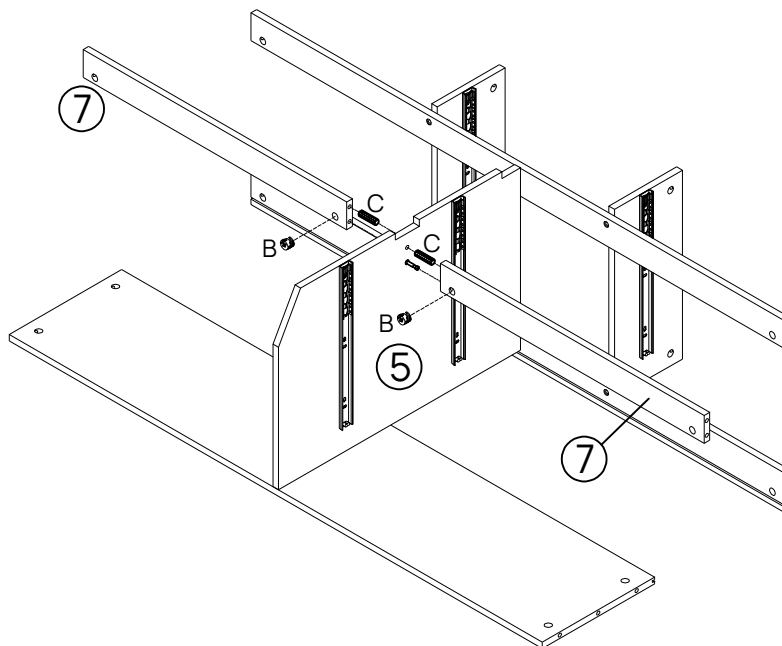

G*4	C*4	N*1
		

Step 14



B*2	C*2
	

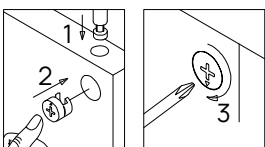

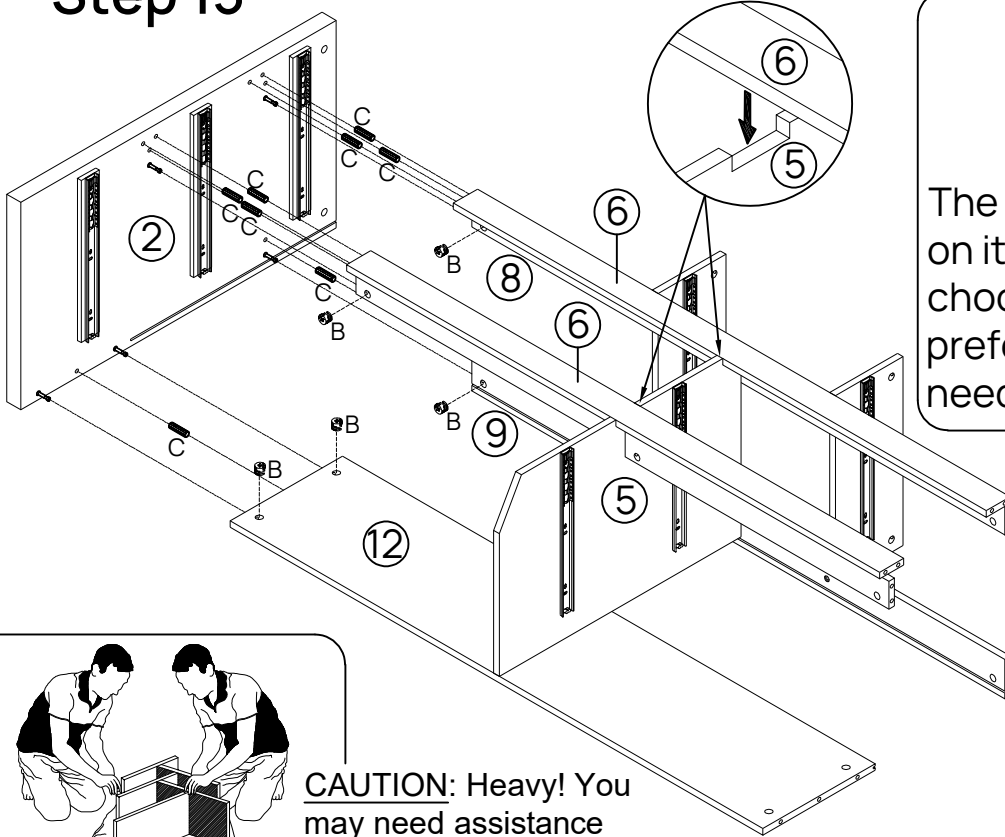

Step 15

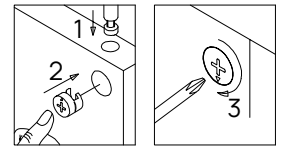

The bar (6) has two colors on its two sides. You can choose according to your preference and usage needs.



B*5	C*8
	

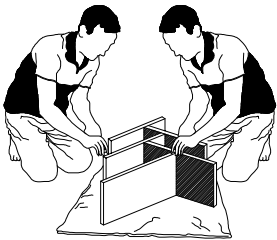

CAUTION: Heavy! You may need assistance with this step

Step 16

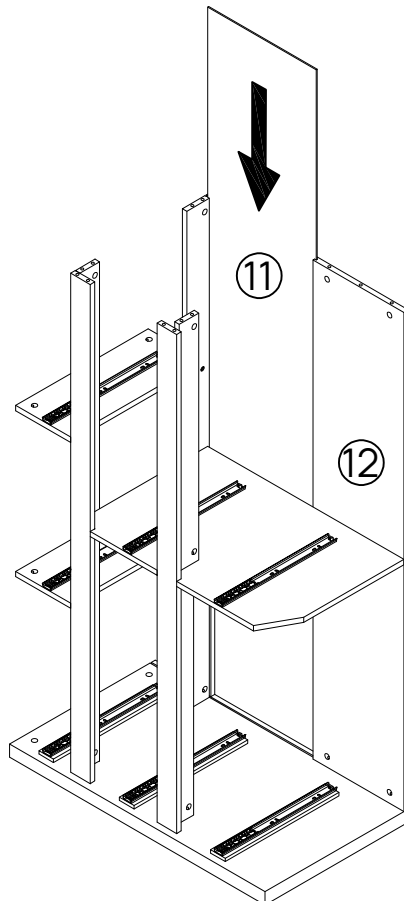

Step 17

CAUTION: Heavy! You may need assistance with this step

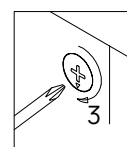
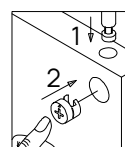
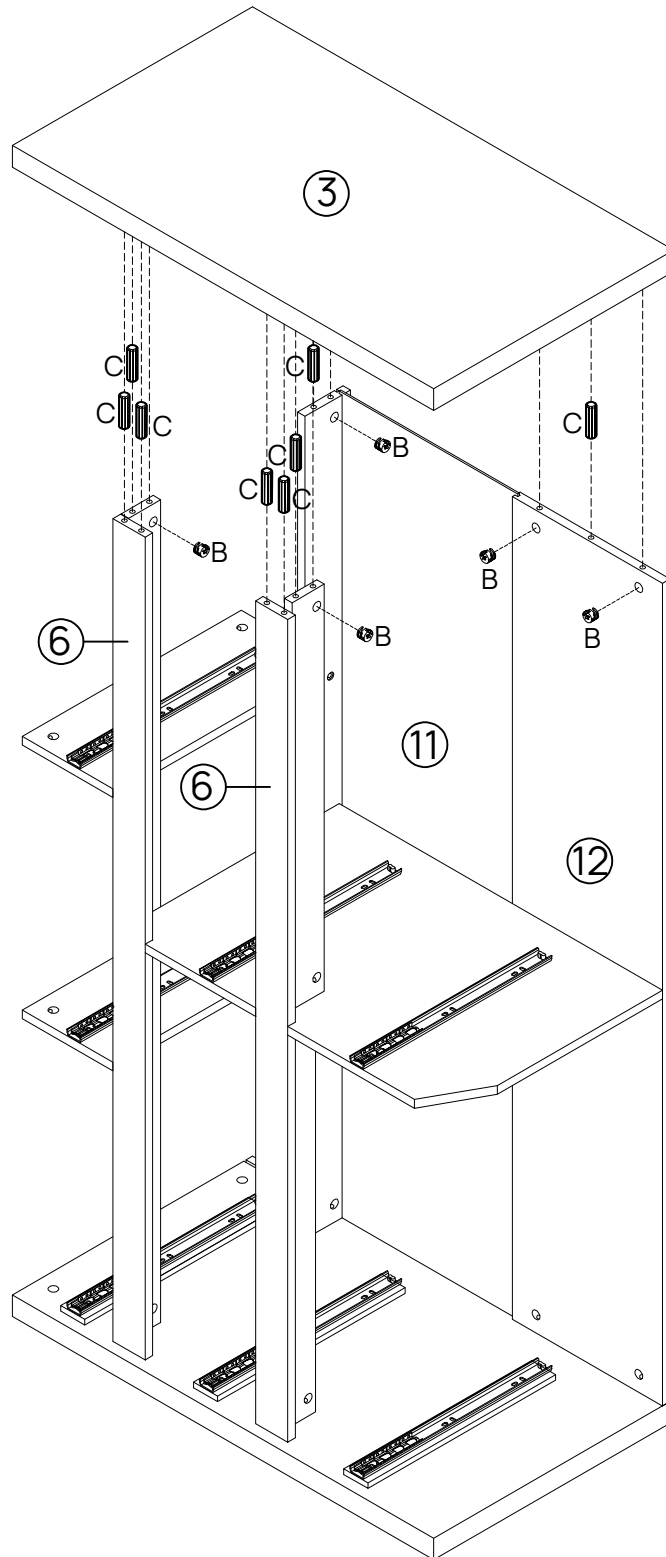
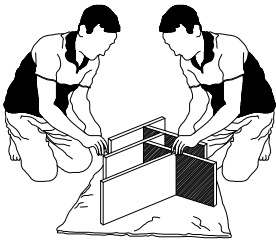

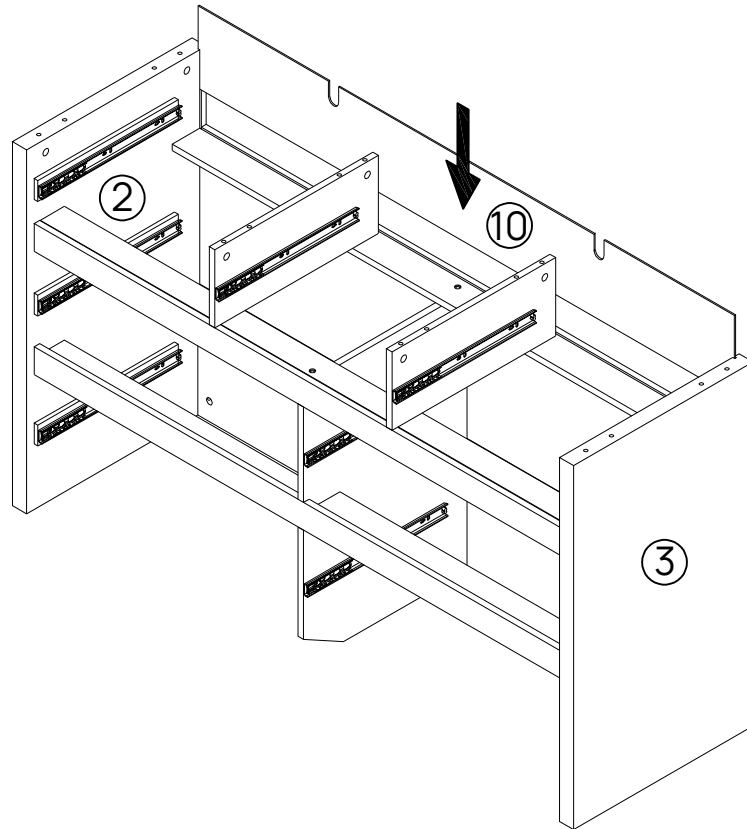

B*5	C*8

Step 18

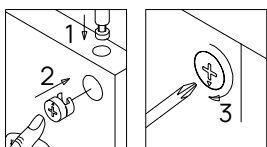
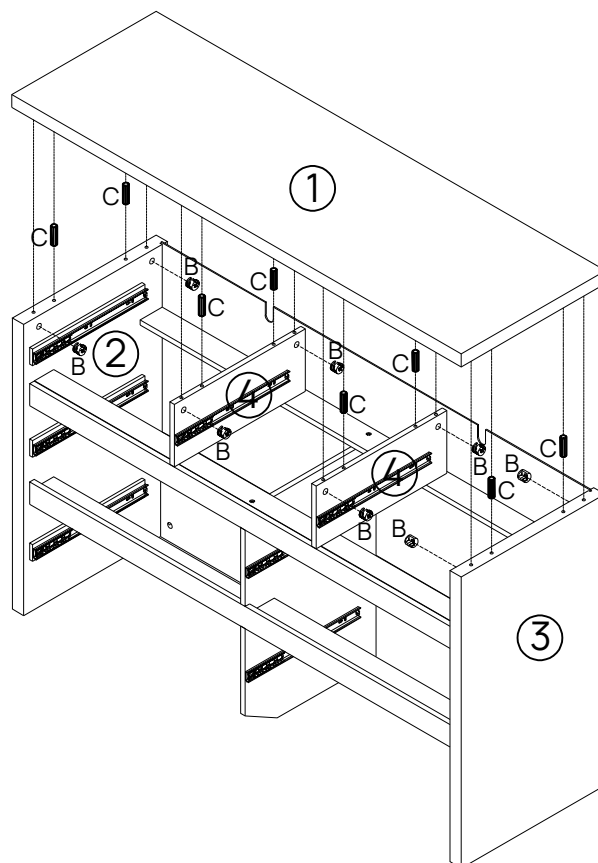

Step 19



B*8	C*8
	

Step 20

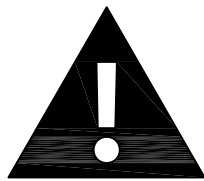
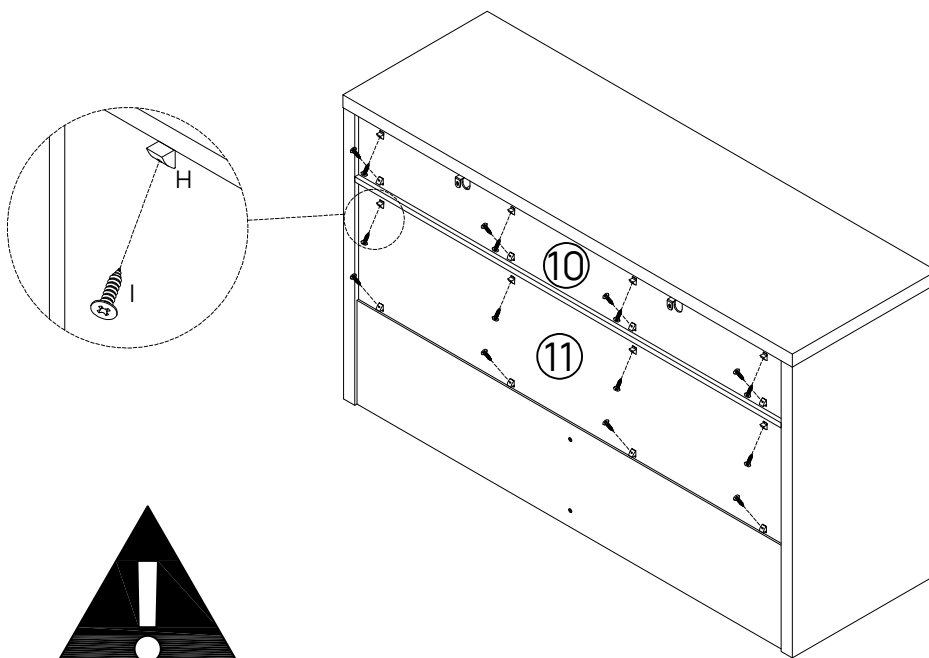

Must Be Installed

H*16	I*16

Step 21

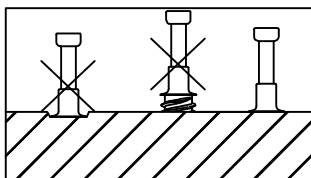
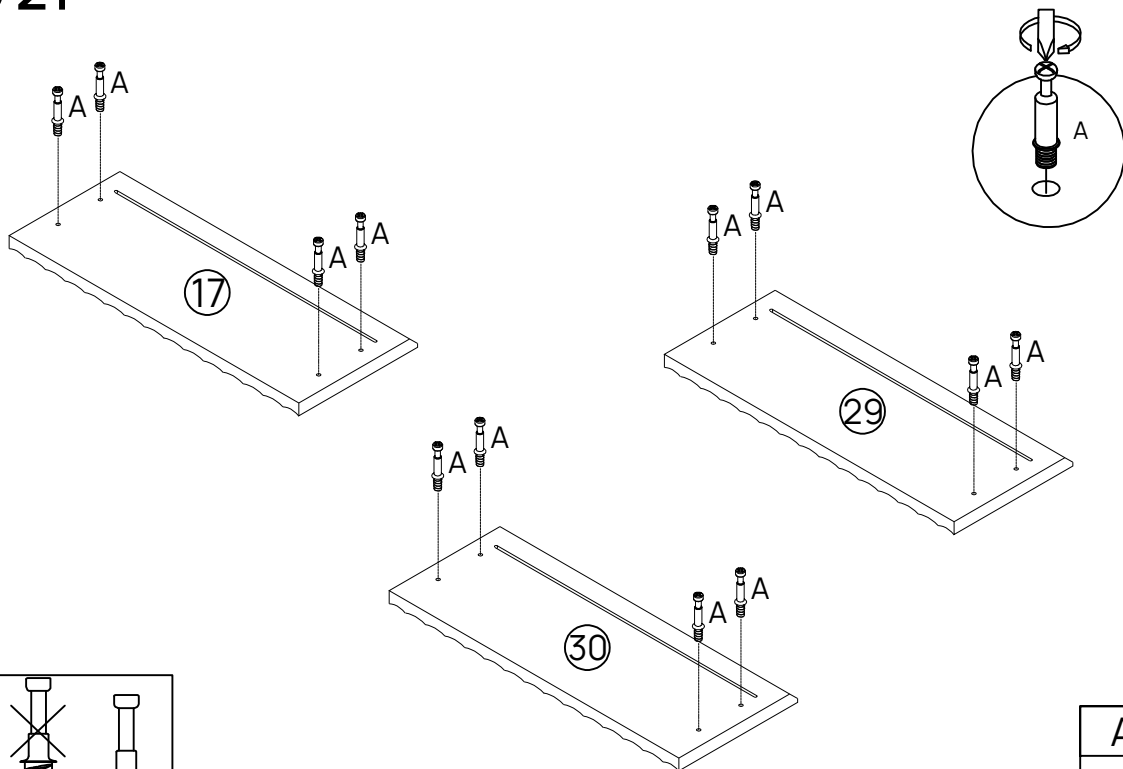

A*12

Step 22

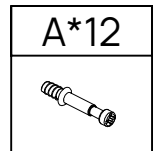
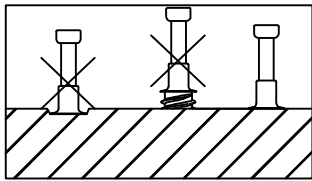
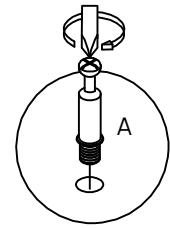
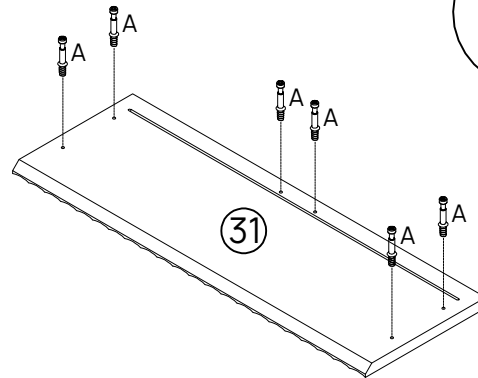
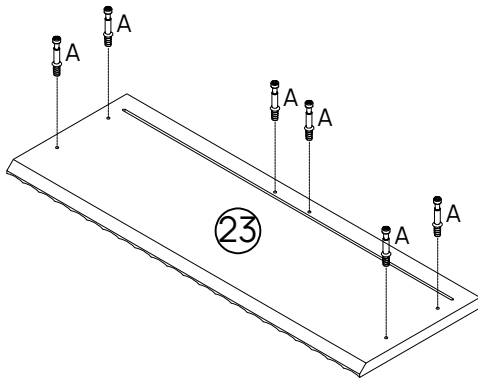

Step 23

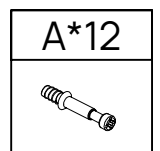
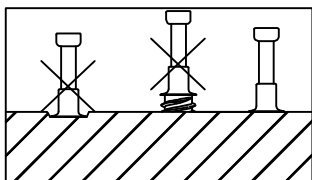
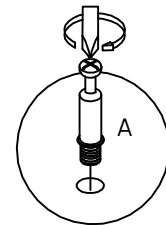
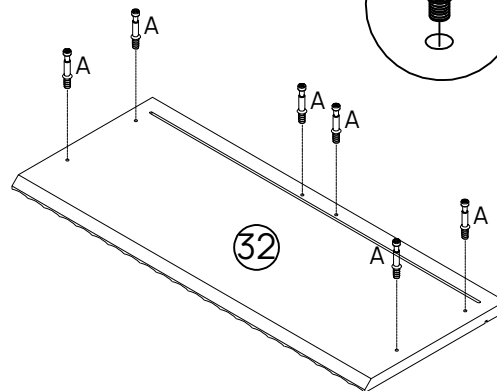
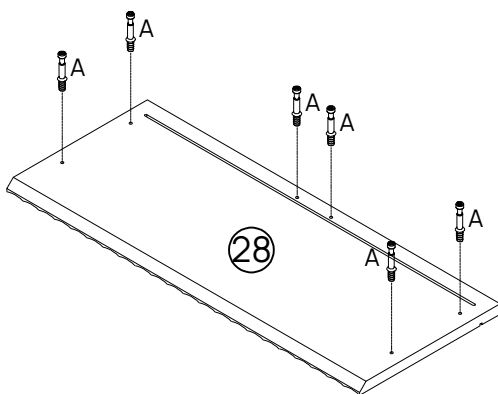

Step 22

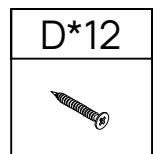
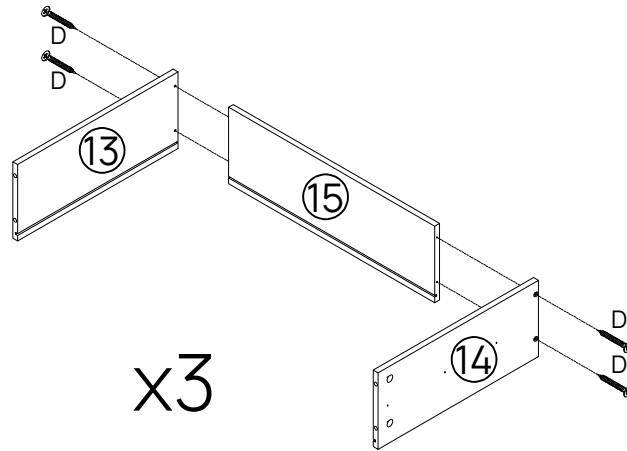

Step 23

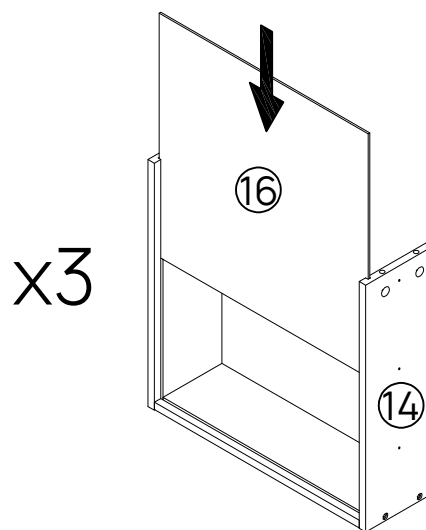

Step 24

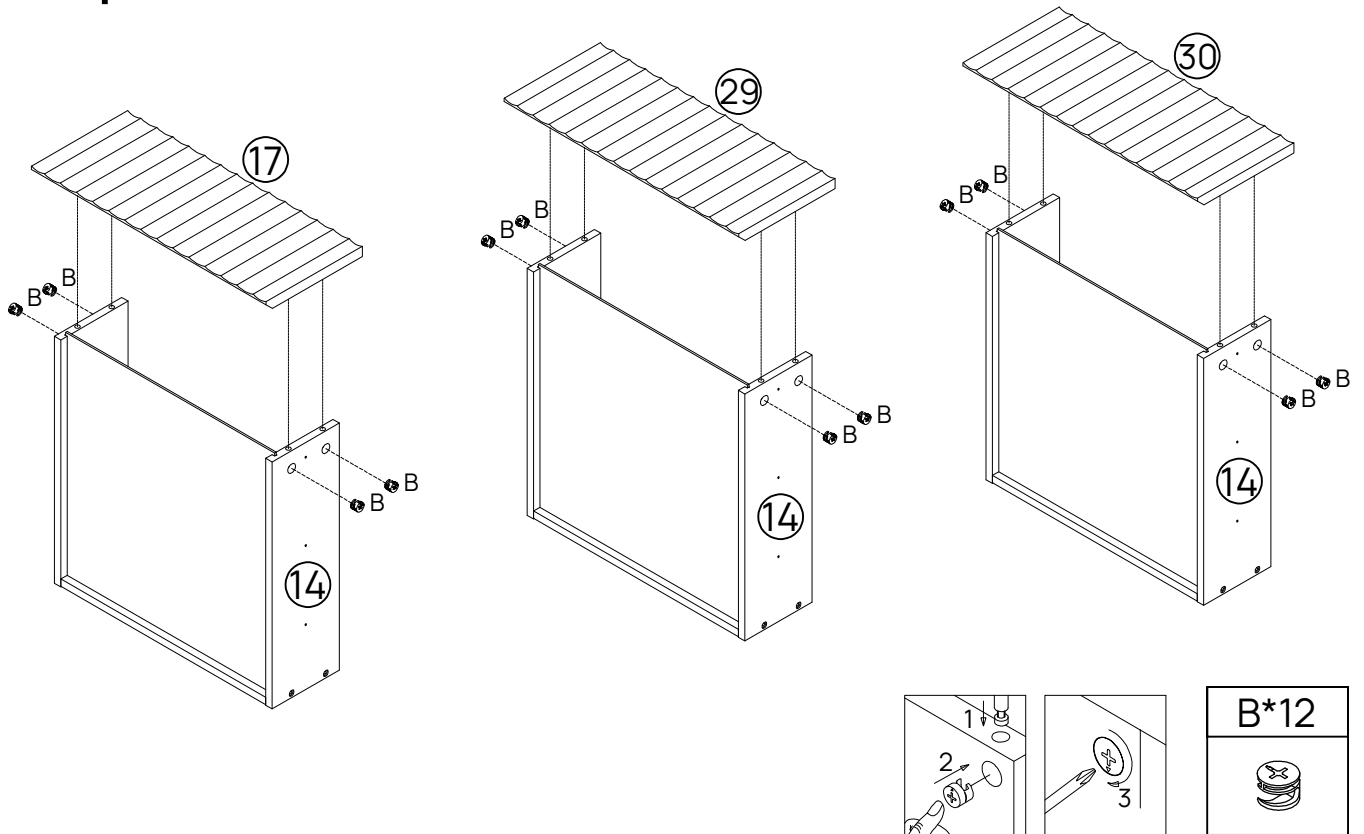

Step 25

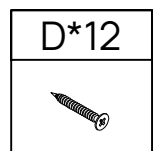
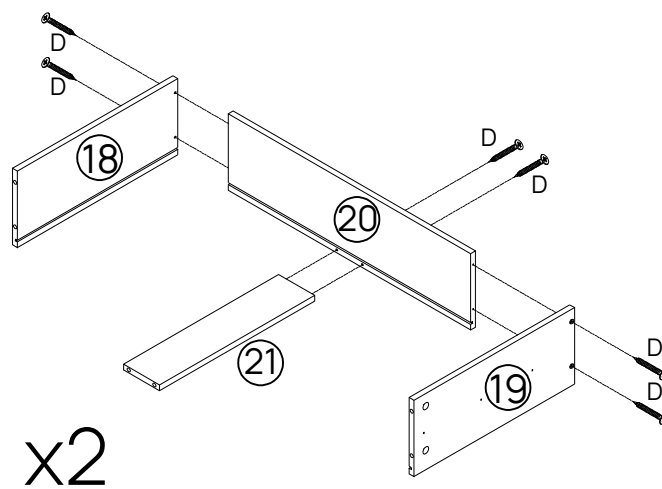

Step 26

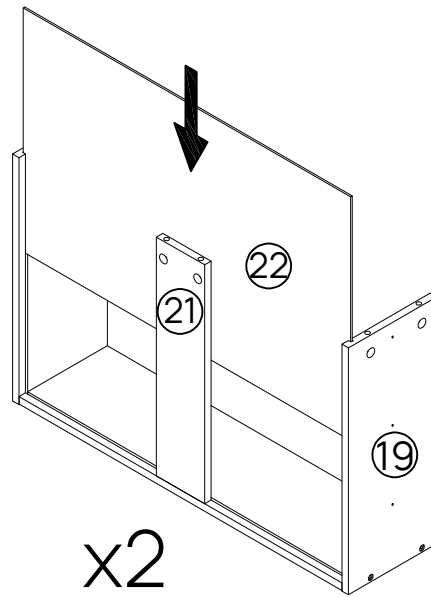

Step 27

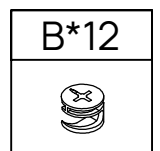
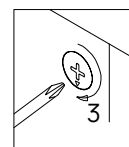
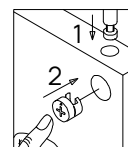
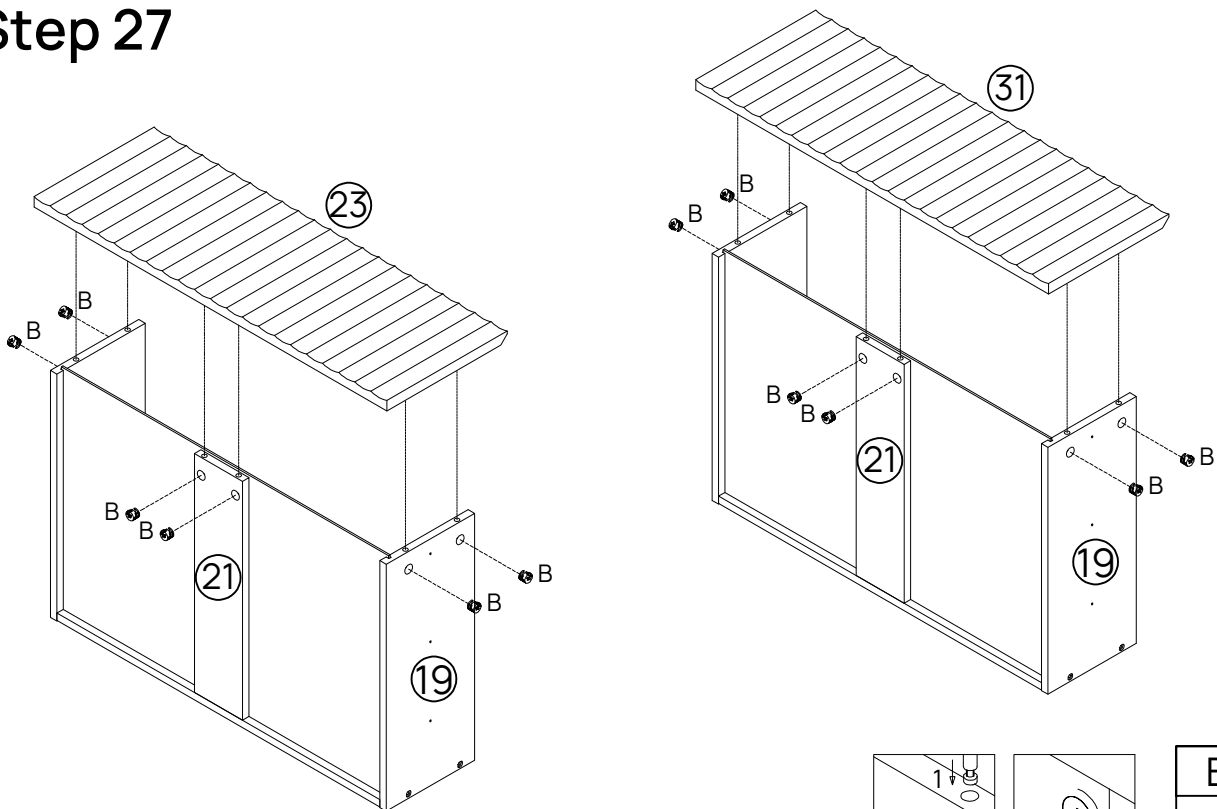

B*12



Step 28

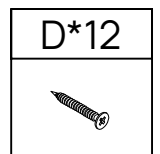
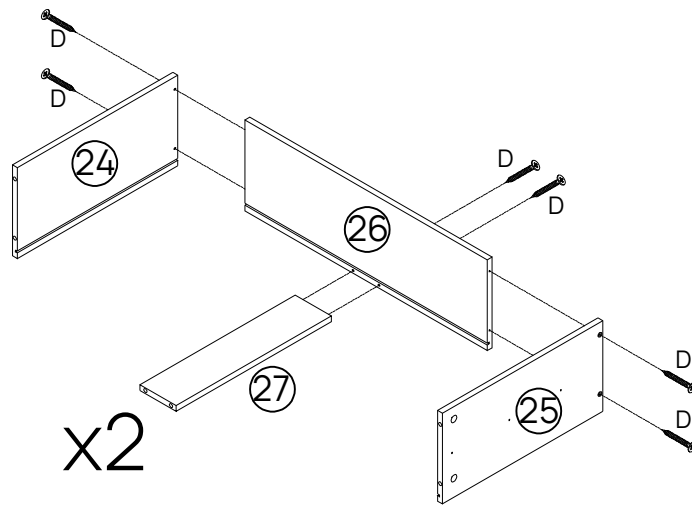

Step 29

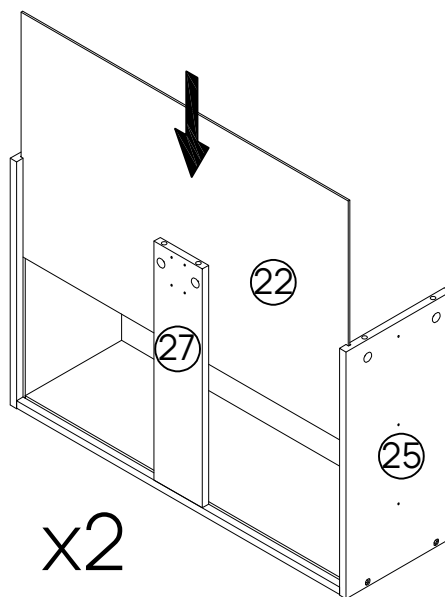

Step 30

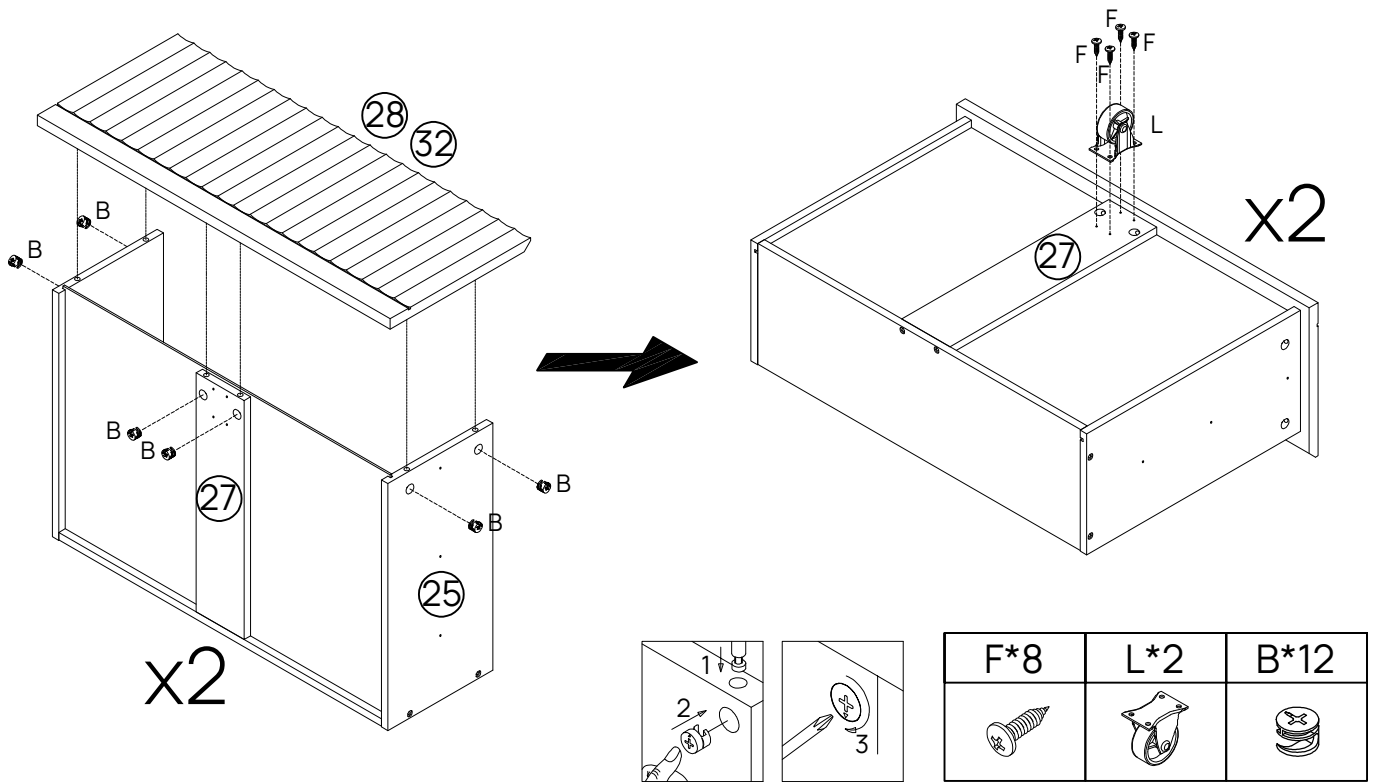

Step 31

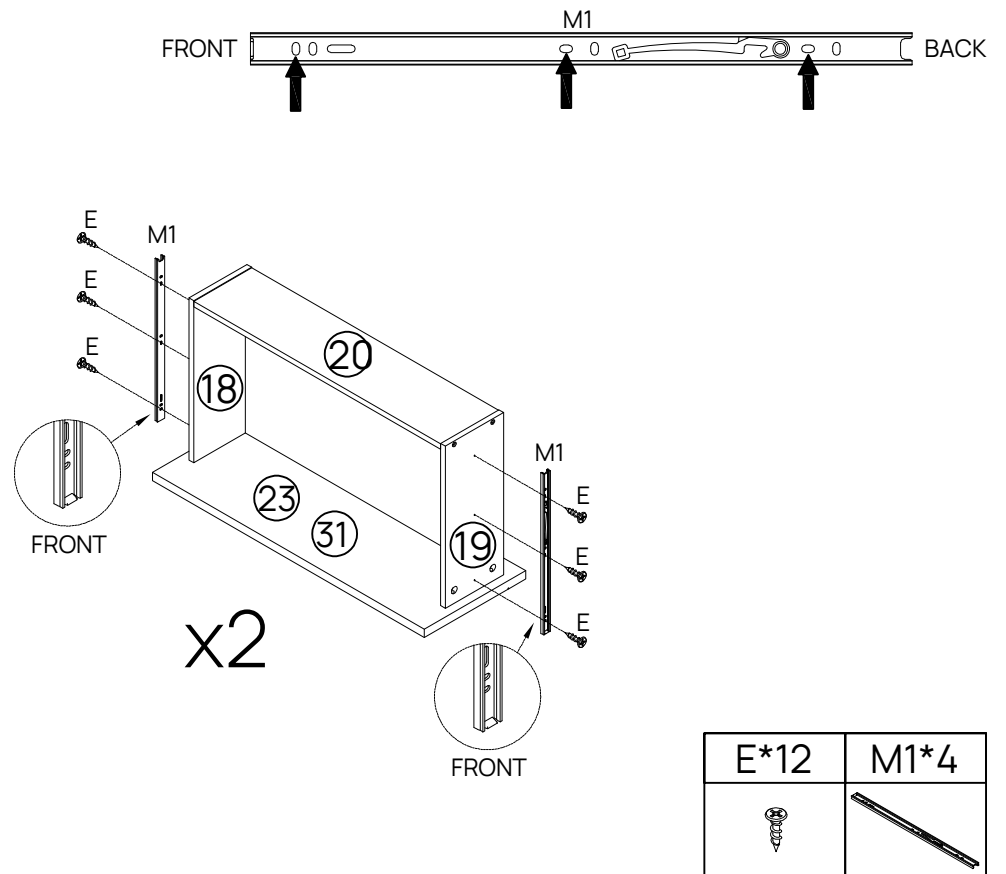

Step 32

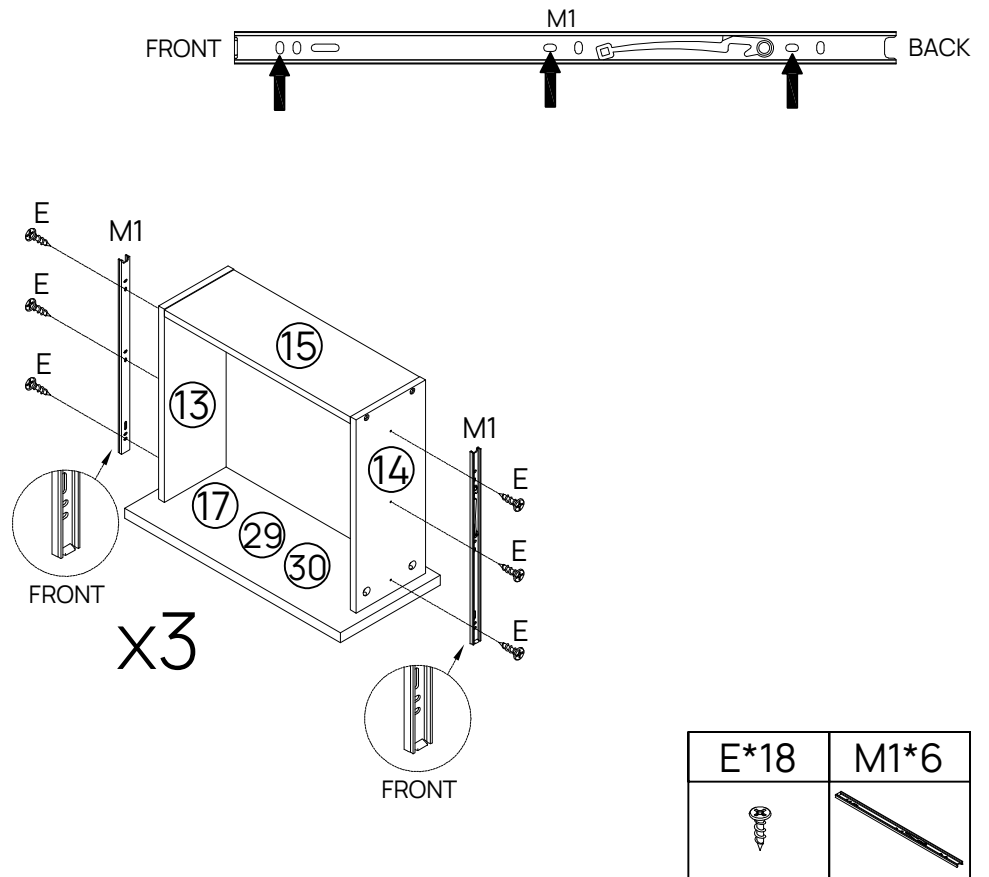

Step 33

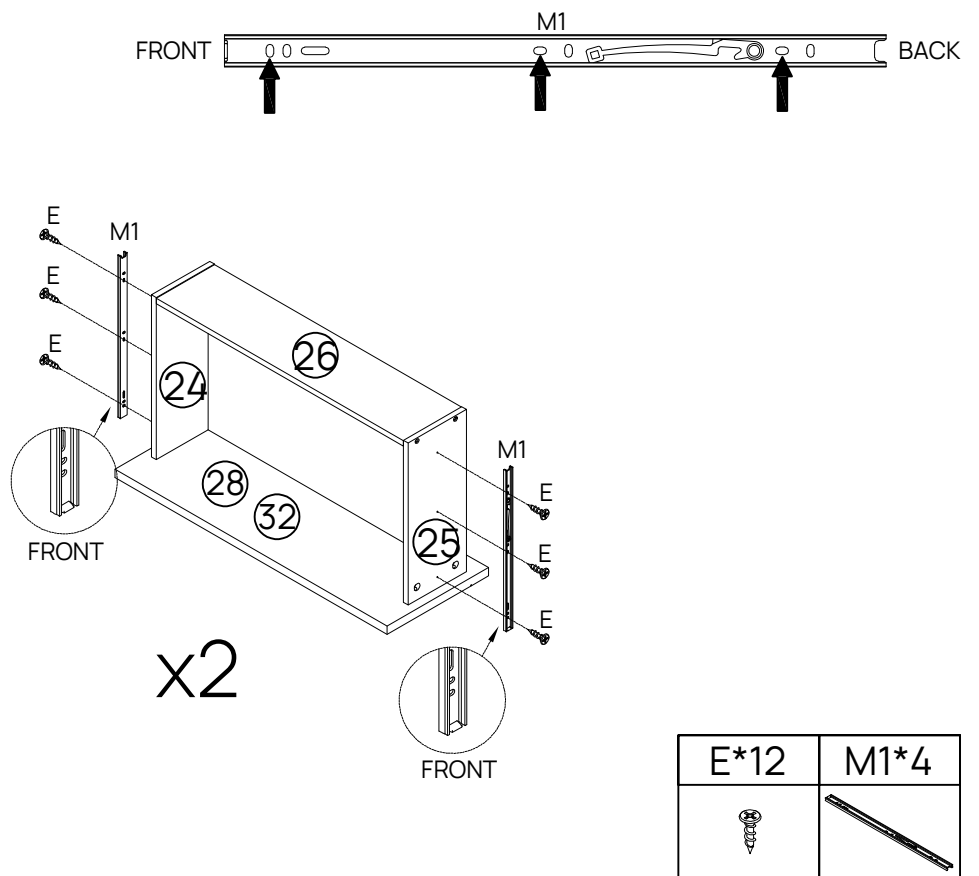

Step 34

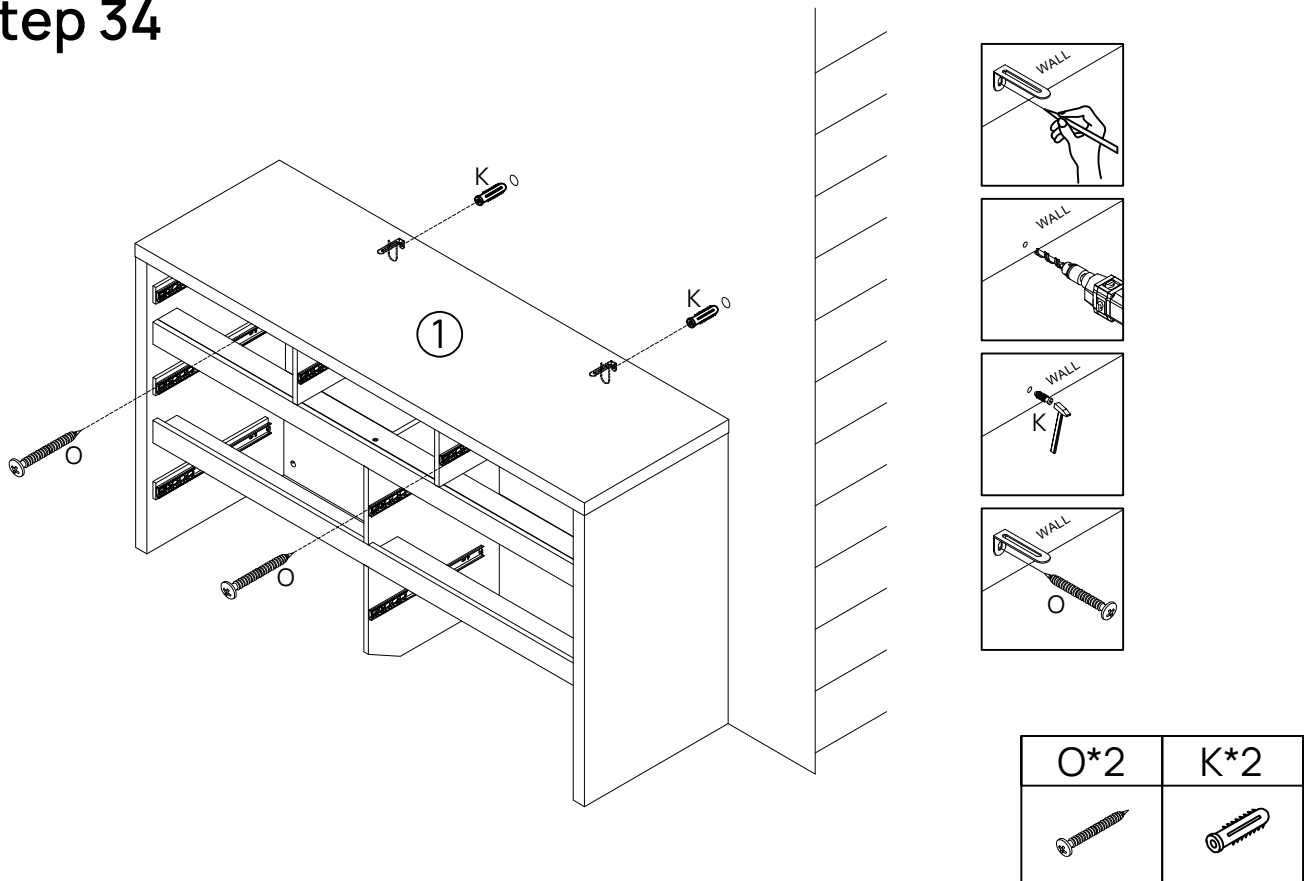

Step 35

Preparation: Slide the inner rail (movable track) to the frontmost position.

Precise installation: Position the drawer horizontally. Align both slide rails precisely, then push inward with steady, even pressure until you hear a "click," indicating the lock is engaged. Installation complete.

WARNING: NEVER FORCE the drawer!
Incorrect start position or forcing the drawer will cause ball bearings to fall out and damage the slide.

Note: If the drawer does not slide smoothly, lift the release lever on one side and press it downward on the other side at the same time. Pull out the slider bracket from the slider arm, then reassemble the drawer until they go in smoothly.

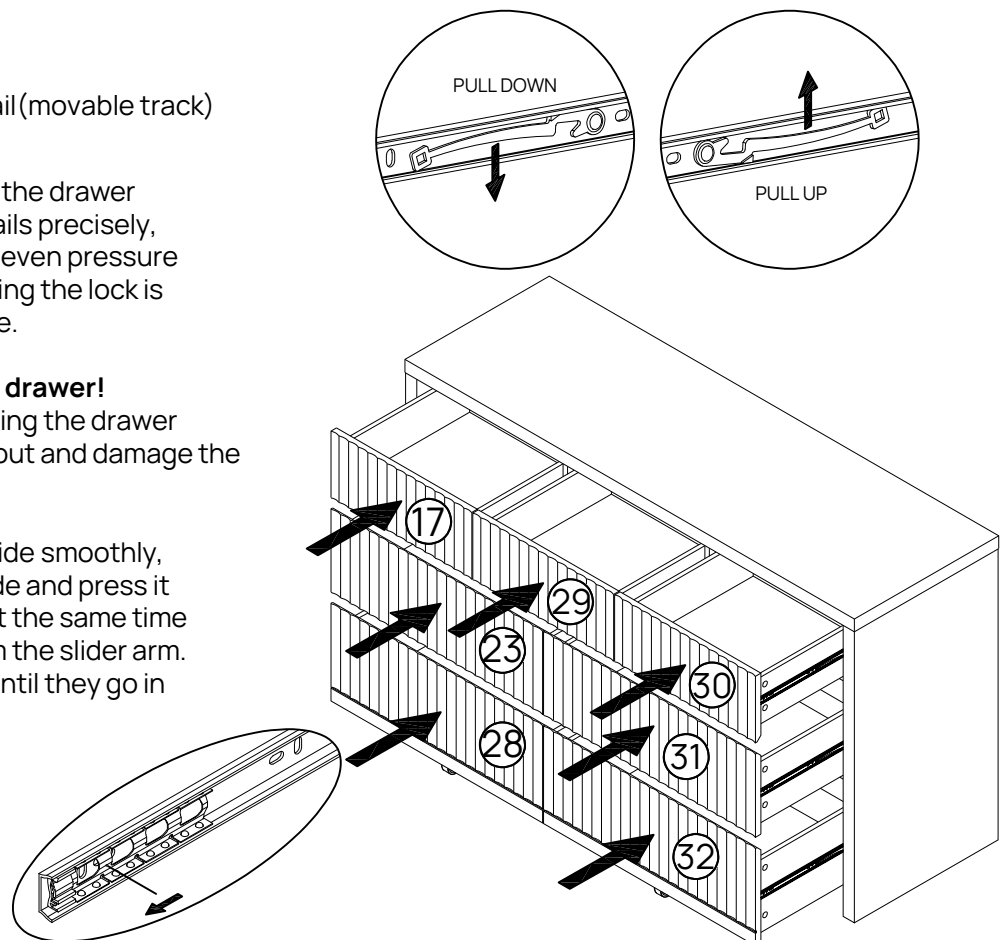

Step 36

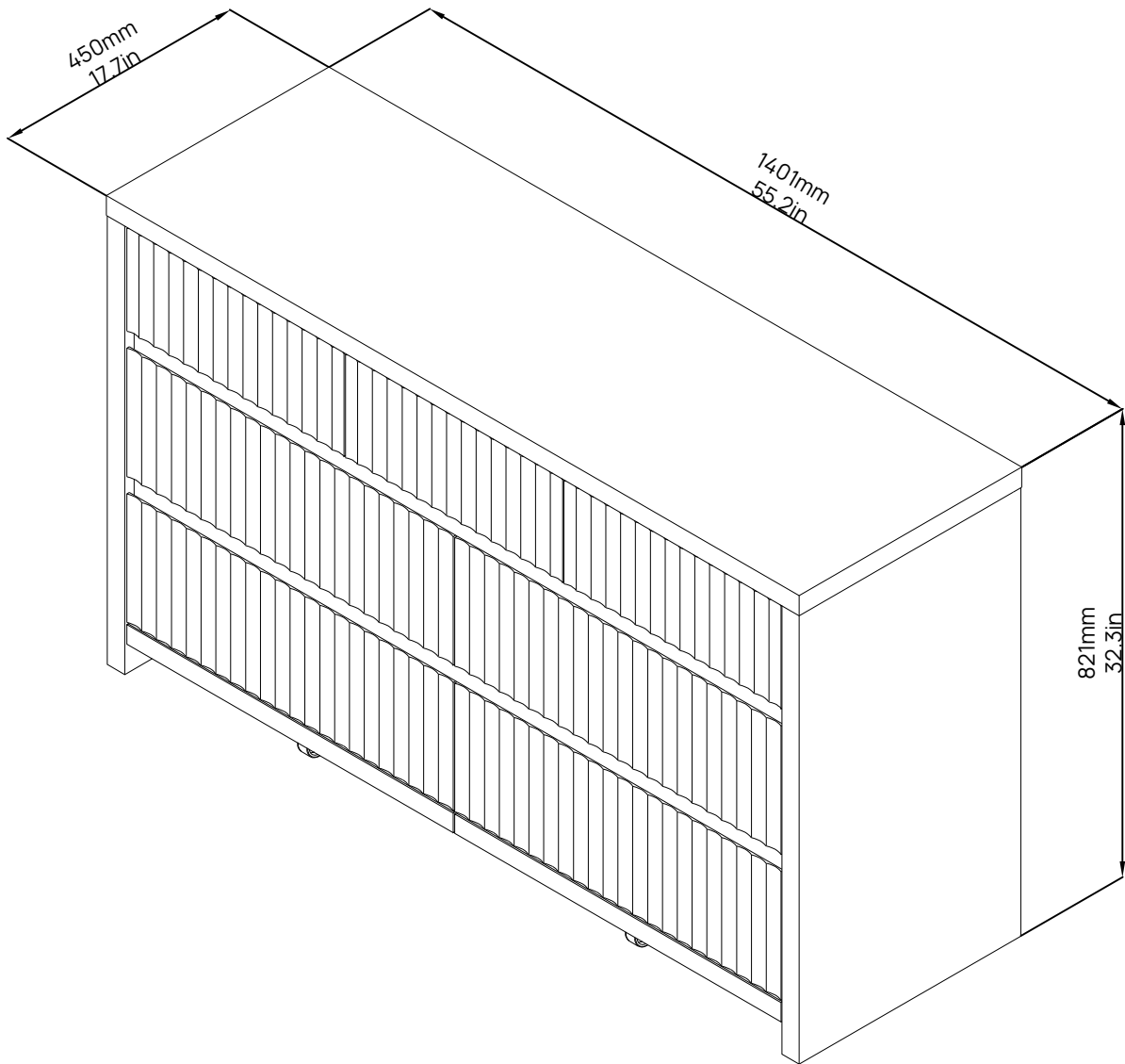

Final Assembly