

ASSEMBLY INSTRUCTIONS

BLACK COFFEE TABLE

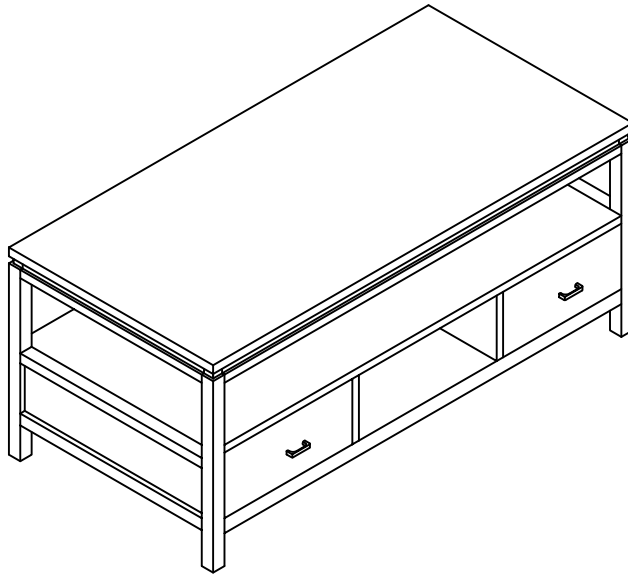

WE ARE HERE TO HELP !









WE DO OUR BEST TO INSURE THAT YOUR FURNITURE ARRIVES IN EXCELLENT CONDITION.

IF YOU NEED ASSISTANCE WITH ASSEMBLY OR REPLACEMENT PARTS, PLEASE CALL
CUSTOMER SERVICE, PRIOR TO RETURNING THE ITEM TO THE STORE.

IMPORTANT:
PLEASE READ ALL INSTRUCTIONS IN THIS BOOKLET BEFORE STARTING ASSEMBLY.
MADE IN VIETNAM

HARDWARE PACKAGE COUNT

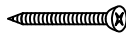
OPEN HARDWARE PACKAGE ON A FLAT SURFACE COVERED WITH NEWSPAPER. COUNT EACH PIECE OF HARDWARE TO MATCH THE QUANTITY NUMBER IN THE HARDWARE LIST COLUMN. CALL CUSTOMER SERVICE IF ANY OF THE PARTS ARE MISSING. FOLLOW THE LETTER IDENTIFICATION WHEN READING THE ASSEMBLY DRAWING "A" THROUGH "H"

ITEM	DESCRIPTION	QTY
A	LOCKING BOLTS 	8
B	CAMS LOCK 	8
C	CAMS BOLTS 	8
D	DRAWER SCREWS 	16
E	HANDLE SCREWS 	4
F	HANDLES 	2
G	LONG SCREWS 	4
H	ALLEN KEY 	1

ALL PARTS ARE LABELED WITH STICKERS MATCHING THE PART IDENTIFICATION NUMBERS LISTED IN LEFT COLUMN.

IMPORTANT

PLEASE USE ALL HARDWARE MENTIONED ABOVE AS THEY WILL ASSURE THE ITEM'S STABILITY AND SAFETY. A SCREWDRIVER IS REQUIRED TO SUCCESSFULLY AND FULLY ASSEMBLE THE PIECE.

PART IDENTIFICATION:

PART	DESCRIPTION	QTY
#1	TOP	1
#2	LEFT SIDE FRAME	1
#3	RIGHT FRAME	1
#4	RIGHT PARTITION	1
#5	LEFT PARTITION	1
#6	SHELF	1
#7	BOTTOM FRAME	1
#8	BACK PANELS	2
#9	DRAWER FRONTS	2
#10	DRAWER SIDES	4
#11	DRAWER BACKS	2
#12	DRAWER BASES	2

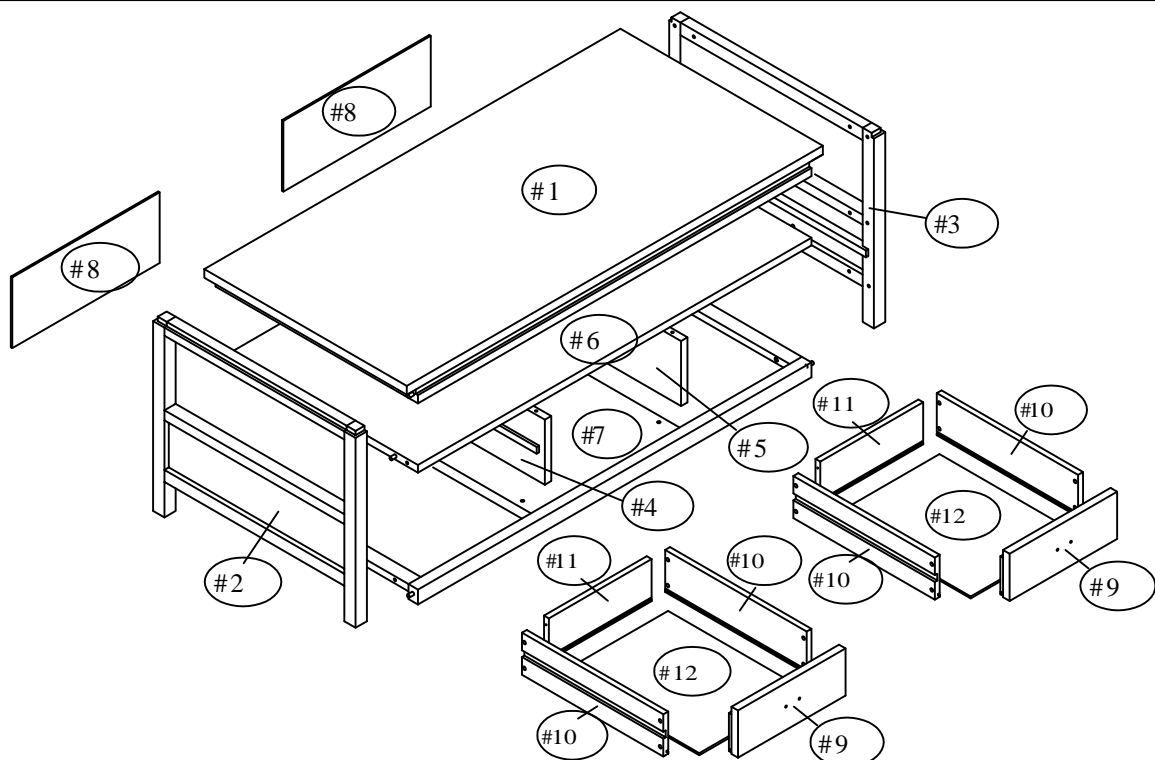

STEP 1

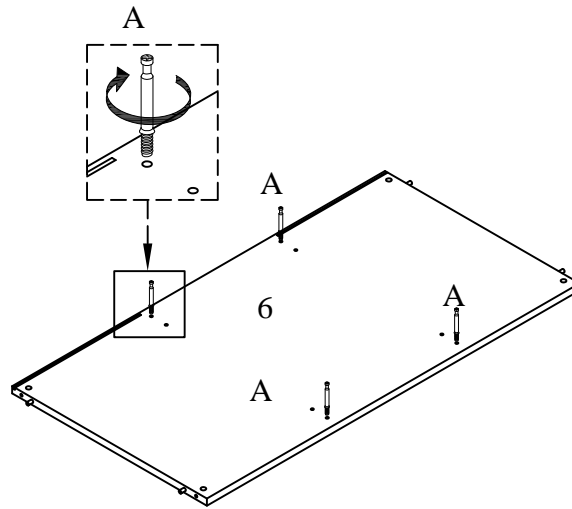

INSERT FOUR LOCKING BOLTS (A) INTO SHELF (6) AND TIGHTEN.

STEP 2

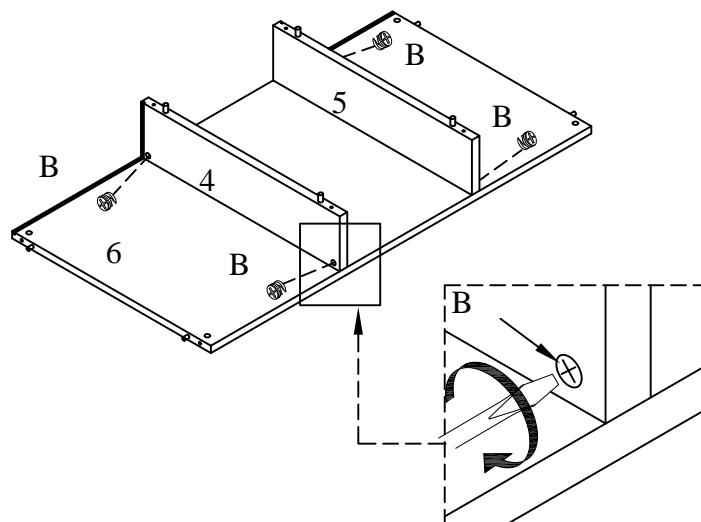

ATTACH RIGHT AND LEFT PARTITIONS (4 & 5) TO SHELF (6). INSERT TWO CAMS (B) INTO EACH PARTITION (4 & 5) AS SHOWN. TIGHTEN THE CAMS (B) WITH A SCREWDRIVER (NOT PROVIDED).

STEP 3

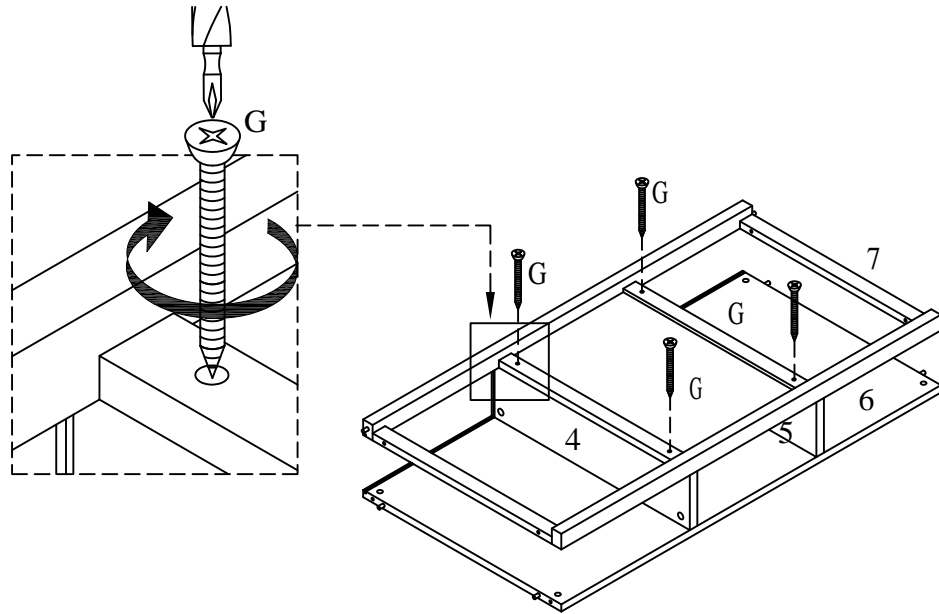

ATTACH BOTTOM FRAME (7) TO BOTH PARTITIONS (4 & 5). INSERT LONG SCREWS (G) AS SHOWN AND TIGHTEN THE SCREWS (G) WITH A SCREWDRIVER (NOT PROVIDED).

STEP 4

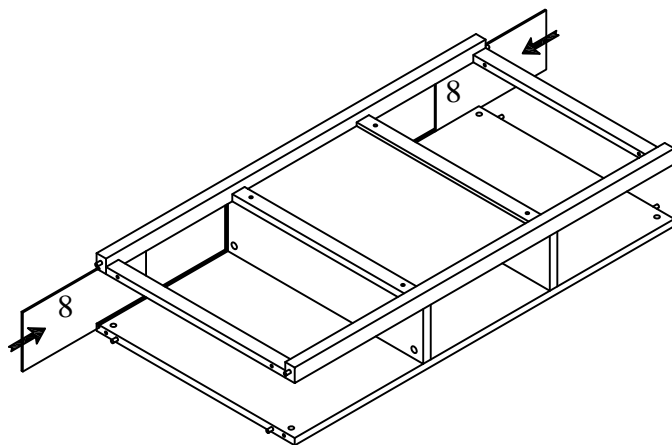

INSERT BACK PANELS (8) INTO THE GROOVES ON PARTS 4, 5, 6, AND 7.

STEP 5

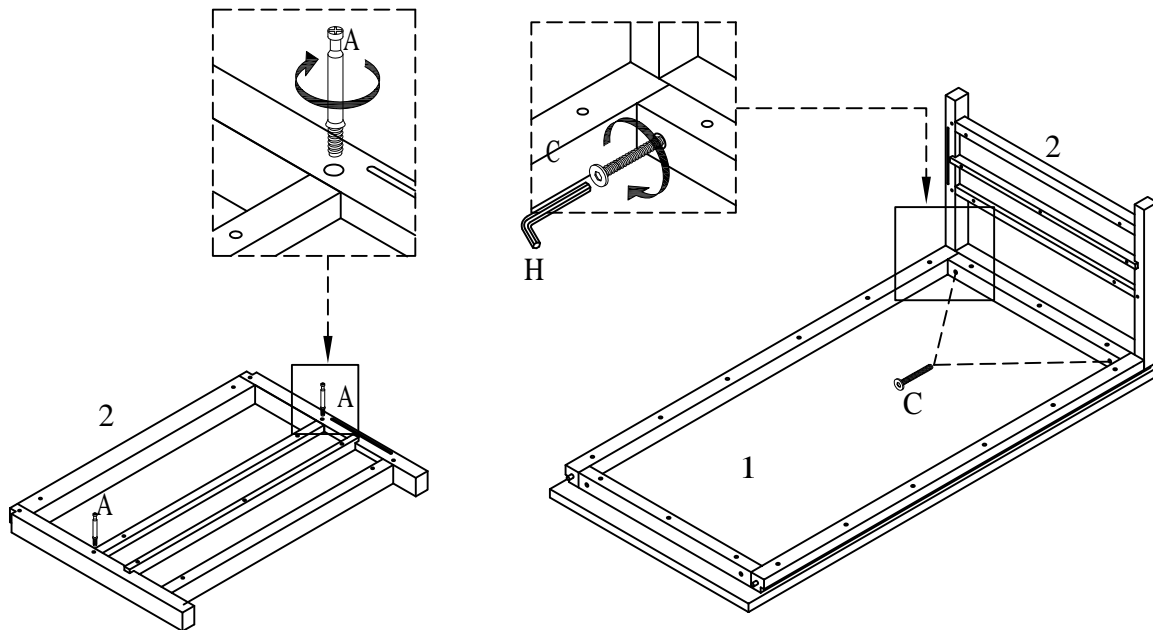

INSERT TWO LOCKING BOLTS (A) INTO SIDE FRAME (2). ATTACH THE SIDE FRAME (2) TO TOP (1). INSERT TWO BOLTS (C) AS SHOWN AND TIGHTEN THE BOLTS (C) WITH THE ALLEN WRENCH (H).

STEP 6

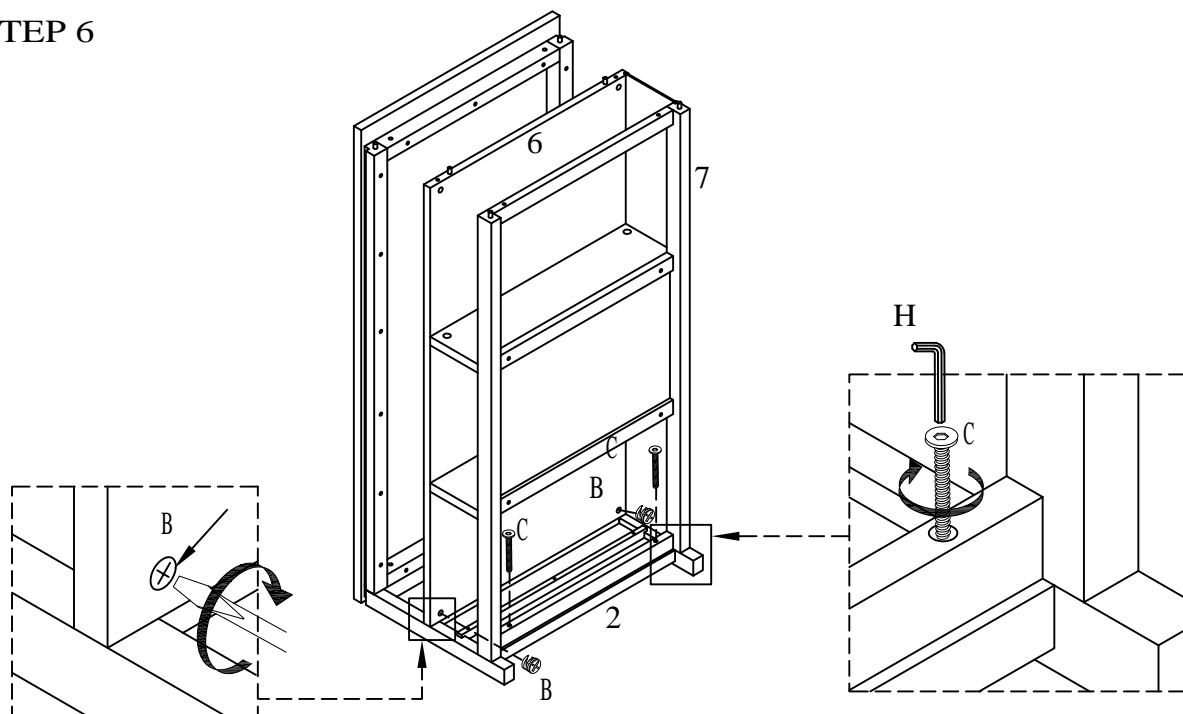

GET THE ASSEMBLED UNIT OF PARTS 4, 5, 6, 7, AND 8 TO ATTACH TO THE ASSEMBLED UNIT OF PARTS 1 AND 2. INSERT TWO BOLTS (C) AS SHOWN AND TIGHTEN THE BOLTS (C) WITH ALLEN WRENCH (H). INSERT TWO CAMS (B) INTO THE SHELF (6) AND TIGHTEN THE CAMS (B) WITH A SCREWDRIVER (NOT PROVIDED).

STEP 7

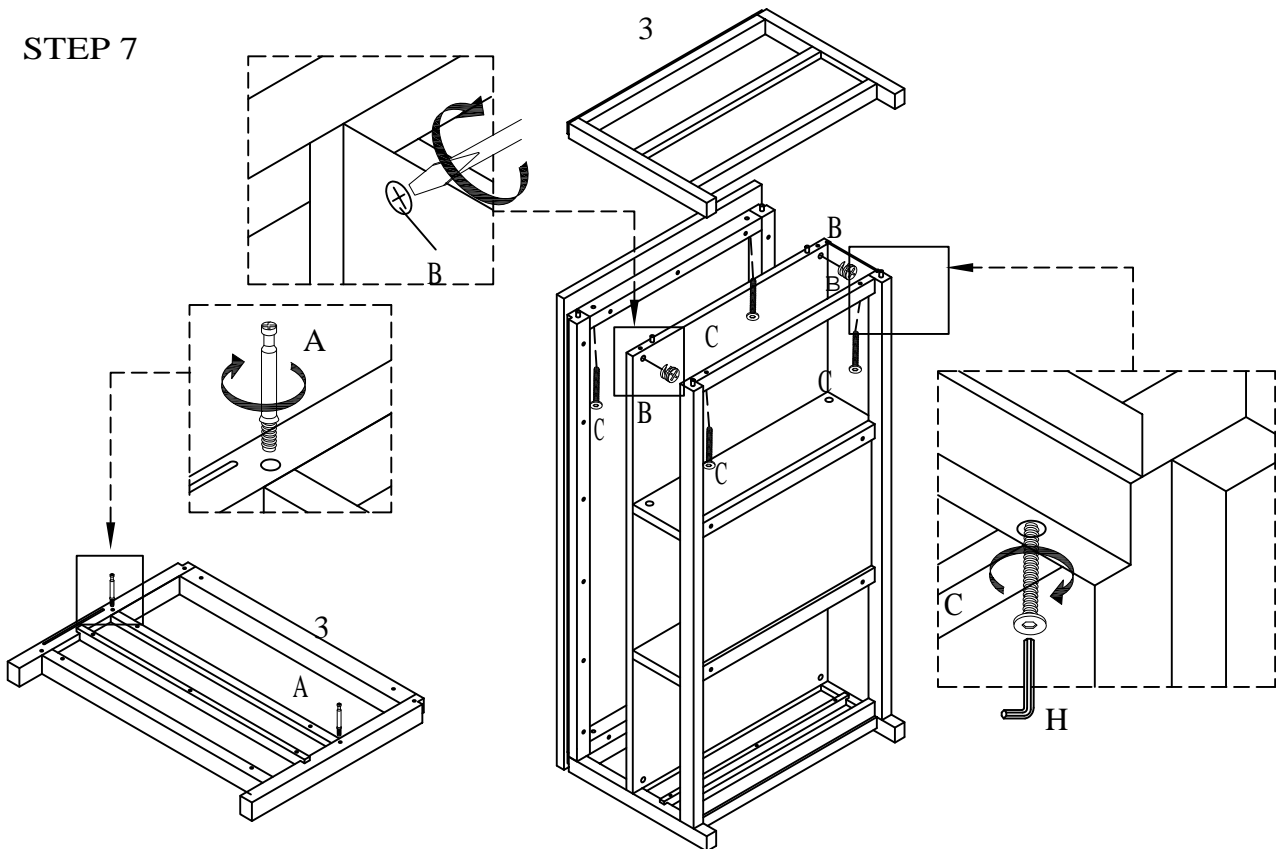

ATTACH THE OTHER SIDE FRAME (3) TO THE ASSEMBLED UNIT. INSERT THE REMAINING TWO BOLTS (C) AS SHOWN AND TIGHTEN THE BOLTS (C) WITH ALLEN WRENCH (H). INSERT THE REMAINING TWO CAMS (C) INTO THE SHELF (6) AND TIGHTEN THE CAMS (C) WITH A SCREWDRIVER (NOT PROVIDED).

STEP 8

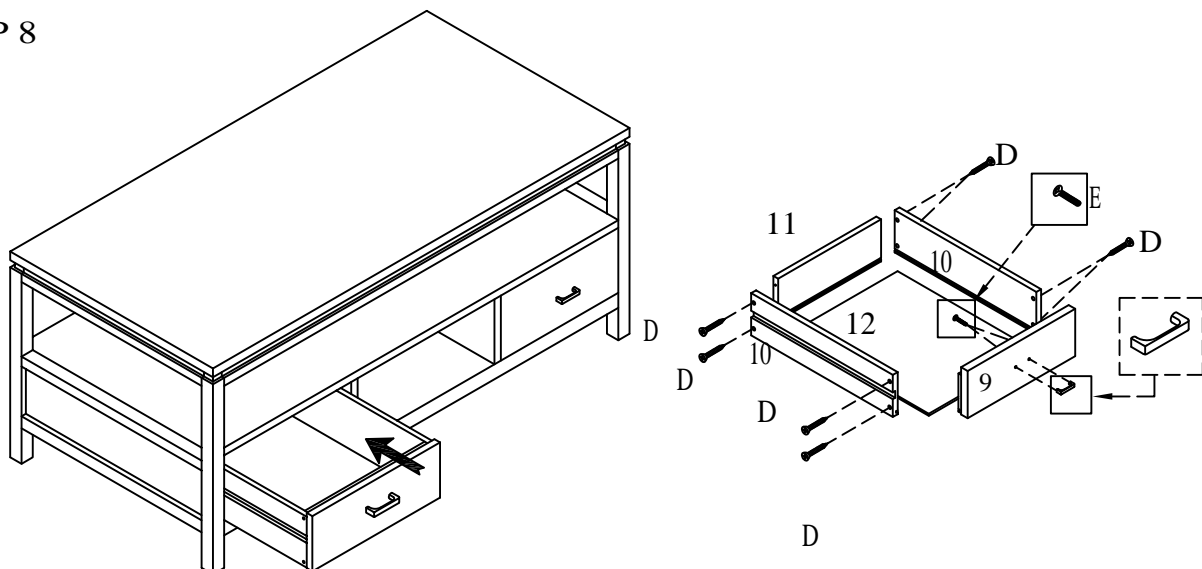

ATTACH DRAWER SIDES (10) TO DRAWER FRONT (9). INSERT DRAWER SCREWS (D) AS SHOWN AND TIGHTEN THE SCREWS (D) WITH A SCREWDRIVER (NOT PROVIDED). INSERT DRAWER BASE (12) INTO THE GROOVES ON DRAWER FRONT AND SIDES (9 & 10). ATTACH DRAWER BACK PIECE (11) TO THE ASSEMBLED DRAWER UNIT. INSERT DRAWER SCREWS (D) AS SHOWN AND TIGHTEN THE SCREWS (D) WITH A SCREWDRIVER (NOT PROVIDED). ATTACH HANDLE (F) ONTO DRAWER FRONT (9) AND INSERT HANDLE SCREWS (E) AS SHOWN. TIGHTEN THE SCREWS (E) WITH A SCREWDRIVER (NOT PROVIDED). FINALLY, SLIDE IN THE DRAWERS AS SHOWN.

COMPLETED ASSEMBLY

