

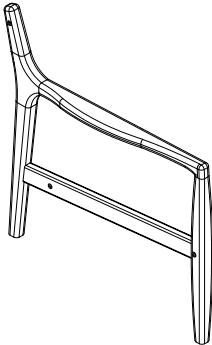

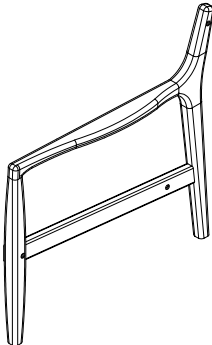
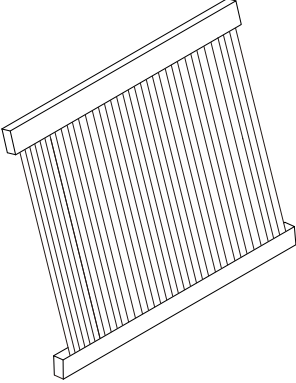
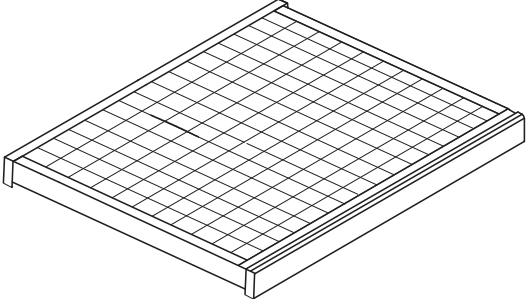

Assembly Instructions

NUMBER	COMPONENT	QUANTITY
A	 <p data-bbox="954 817 1161 862">Right arm</p>	1PC
B	 <p data-bbox="970 1254 1145 1299">Left arm</p>	1PC

Assembly Instructions

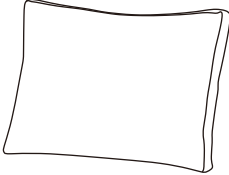
NUMBER	COMPONENT	QUANTITY
C	 <p>Backrest</p>	1PC
D	 <p>Seat</p>	1PC
E	 <p>Seat cushion</p>	1PC
F	 <p>Back cushion</p>	1PC

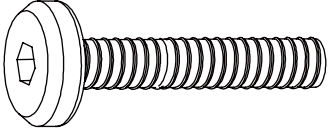
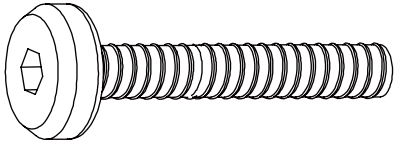
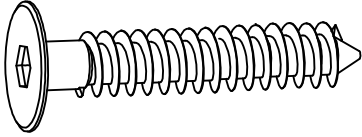
Assembly Instructions

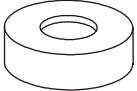
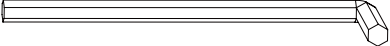
NUMBER	COMPONENT	QUANTITY
G	 <p>BoltM6x40mm</p>	4PCS
H	 <p>BoltM6x55mm</p>	4PCS
I	 <p>ScrewM6x50mm</p>	4PCS
J	 <p>M6 Flat washer</p>	6PCS
K	 <p>M6 Plastic washer</p>	4PCS
L	 <p>Allen Key</p>	1PC

Assembly Instructions

1

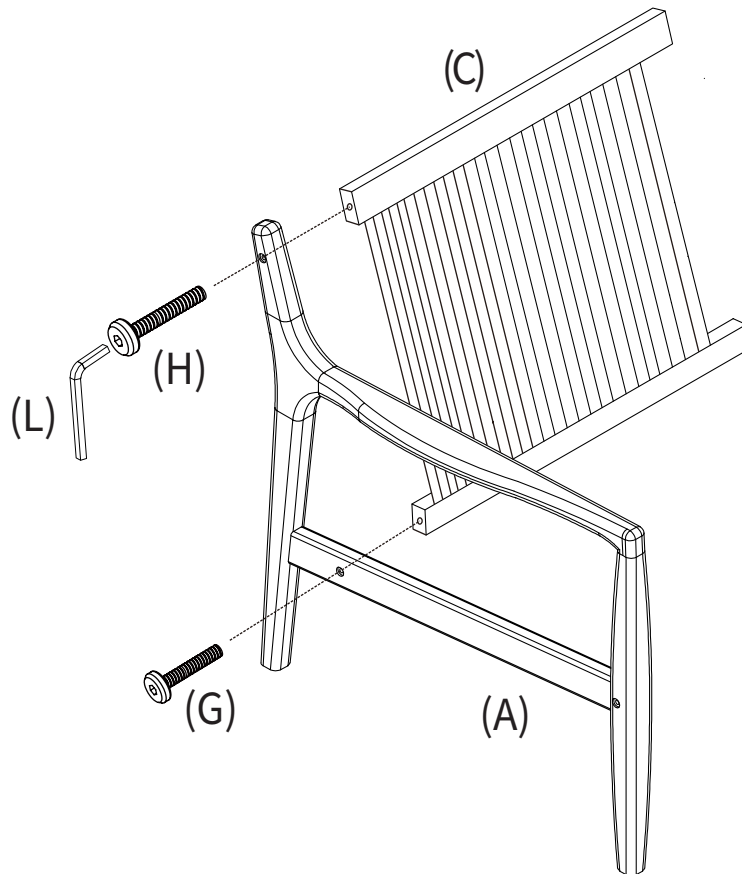

Place Right arm (A) in corresponding positions with Backrest (C).
Secure with Bolt M6x40 (G) and Bolt M6x55 (H) in the order as shown.
Engage all of the bolts by hand, then tighten them using the Allen key (L).

Assembly Instructions

2

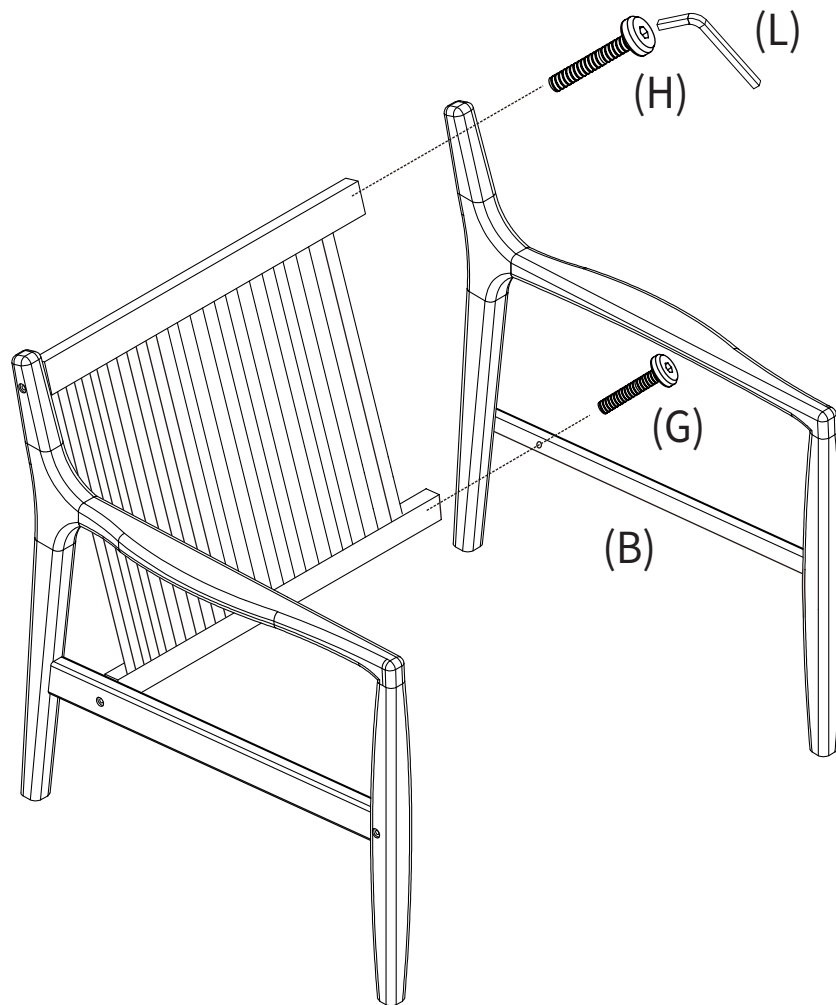

Place Left arm (B) in corresponding positions with Backrest (C).
Secure with Bolt M6x40 (G) and Bolt M6x55 (H) in the order as shown.
Engage all of the bolts by hand, then tighten them using the Allen key (L).

Assembly Instructions

3

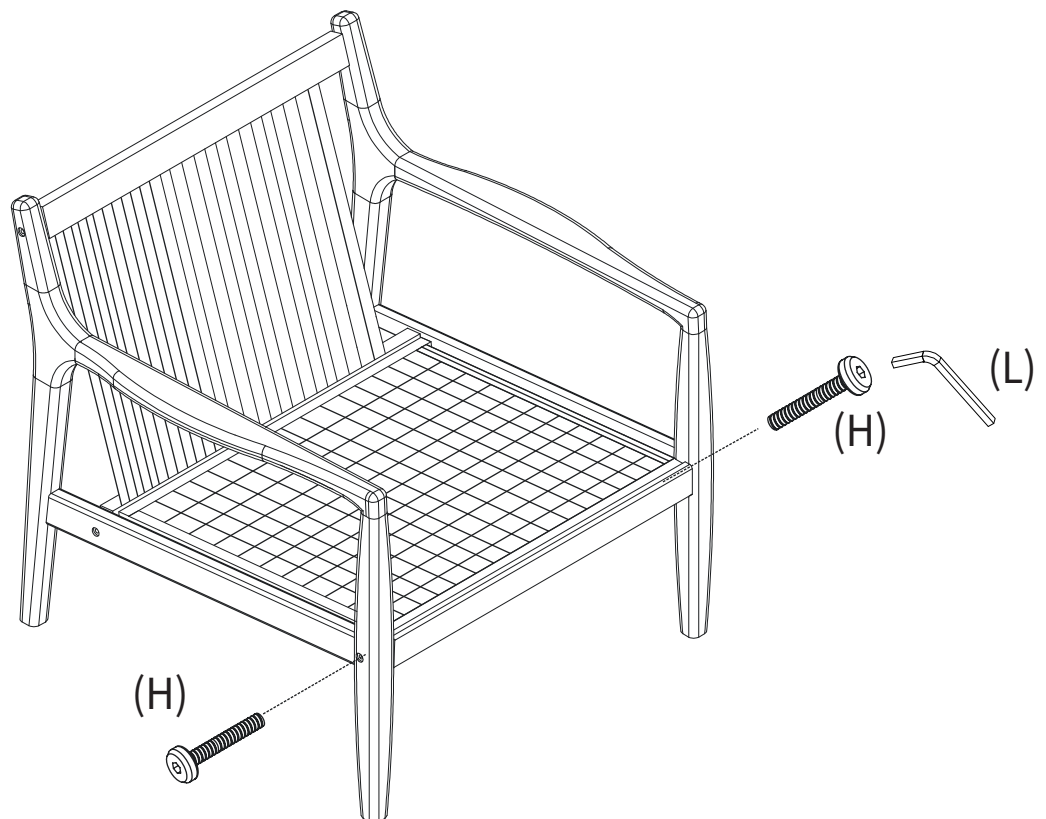
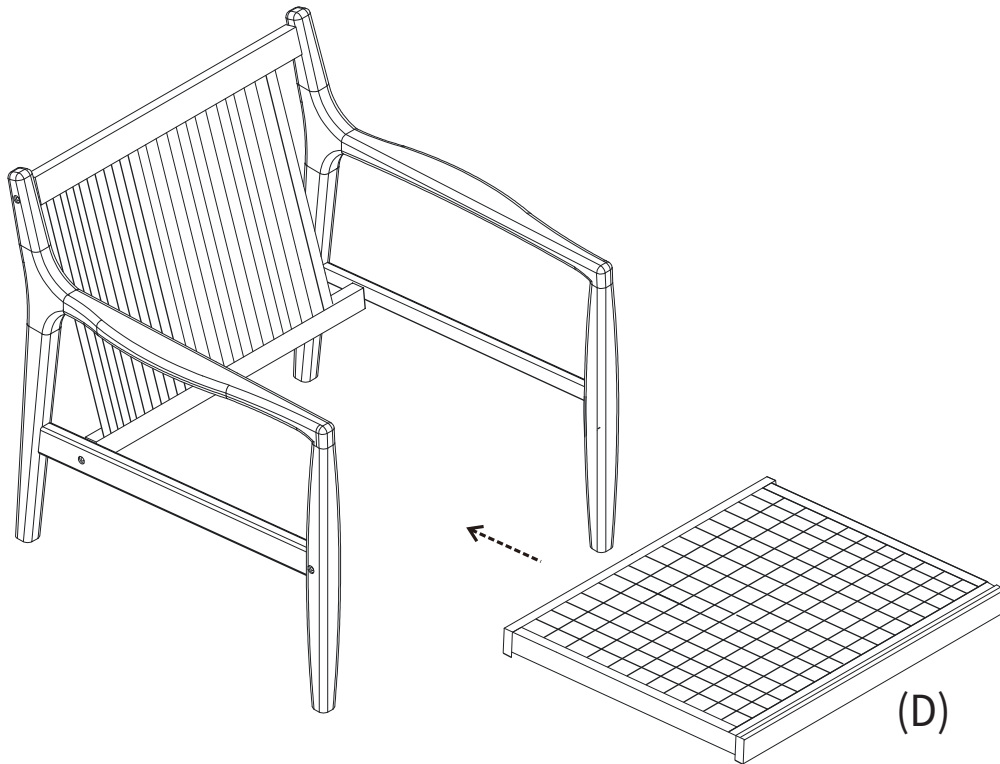

Place Seat (D) between Right arm (A) and Left arm (B) in corresponding positions.

Secure with Bolt M6x55 (H) in the order as shown.

Engage all of the bolts by hand, then tighten them using the Allen key (L).

Assembly Instructions

4

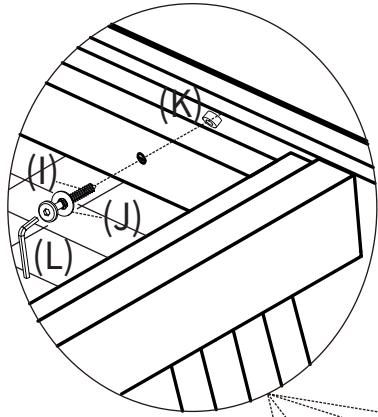

X 4

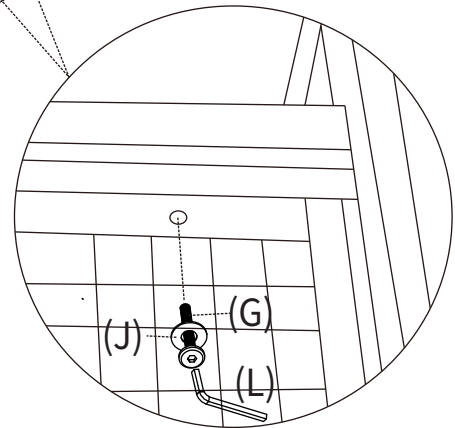
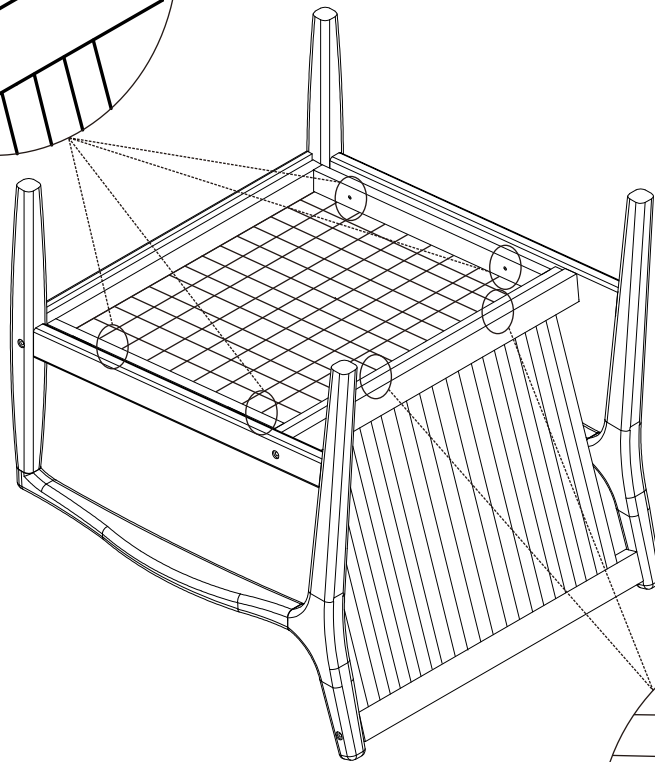

X 2

Secure with Bolt M6x40 (G) and Flat washers (J) and stacking the hardware in the order as shown. Engage all of the bolts by hand, then tighten them using the Allen key (L) to connect the Seat (D) with Backrest (C).

Place Plastic washer (K) between the Seat (D) with Right arm (A) + Left arm (B), after that secure with Screw M6x50 (I) and Flat washers (J) and stacking the hardware in the order as shown. Then tighten them using the Allen key (L) to connect the Seat (D) with Right arm (A) + Left arm (B).

Assembly Instructions

6

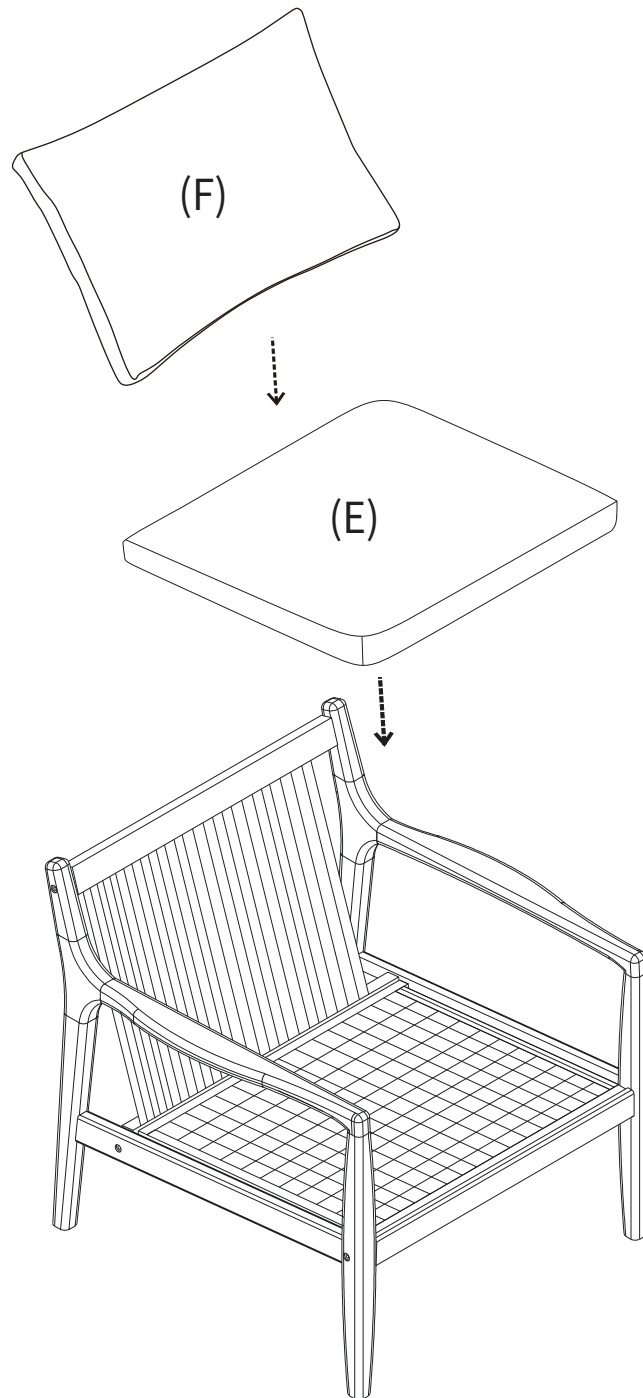

Place Seat cushion (E) and Back cushion (F) onto assembly as shown.