

Assembly Instruction (WLF-C21-1)

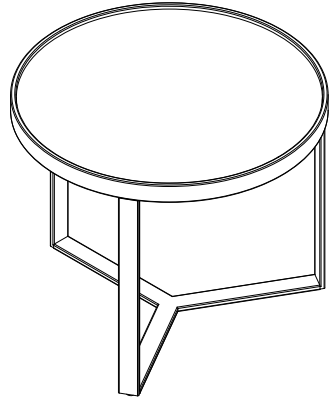

Parts List Open the hardware check all parts QTY, thanks

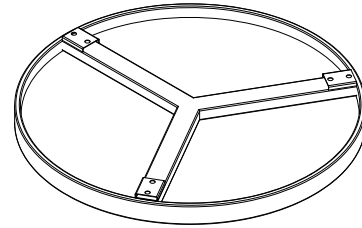

A x 1

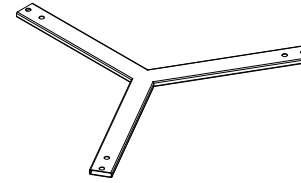

B x 1

⚠ Assemble on a mat that is not easy to scratch
The screw must be loose to finish



C x 3

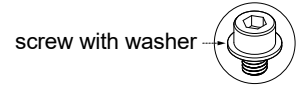

screw with washer



D x 9



E x 3



F x 1

("D" Screwing tool)
(Tighten clockwise)

Step 1

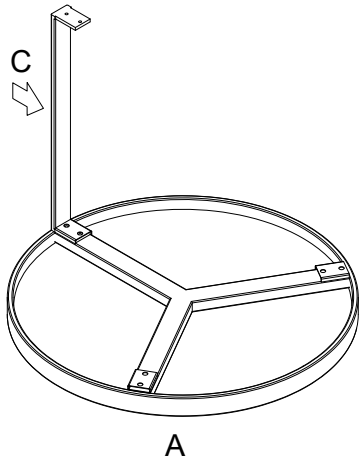

A

Step 2

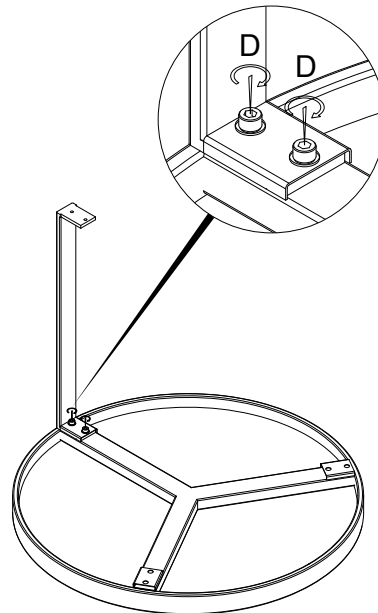

Step 3

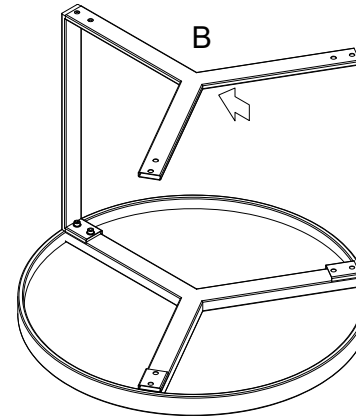

Step 4

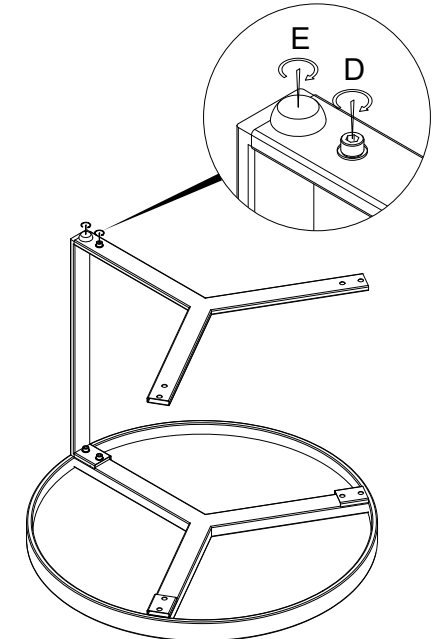

Step 5

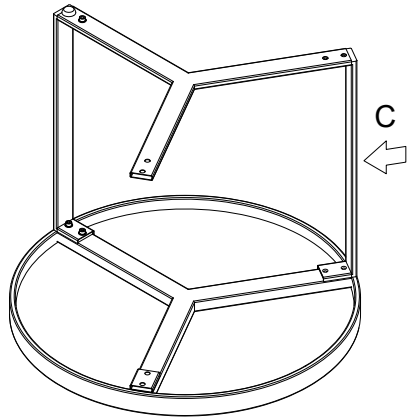

Step 6

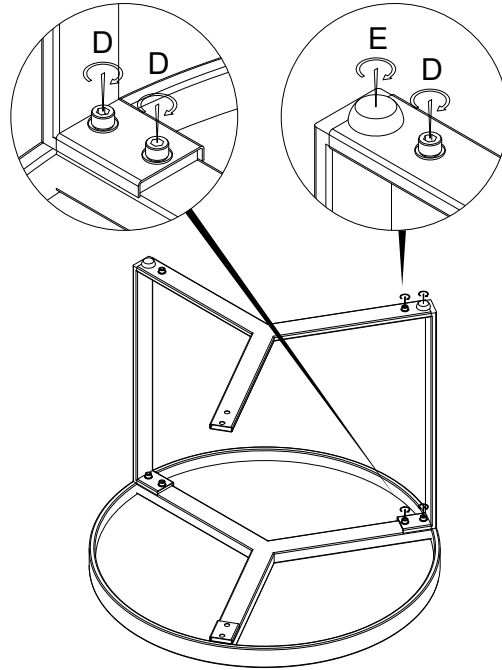

Step 7

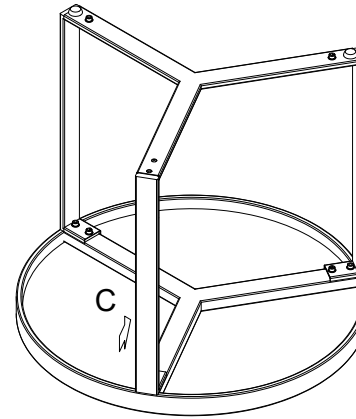

Step 8

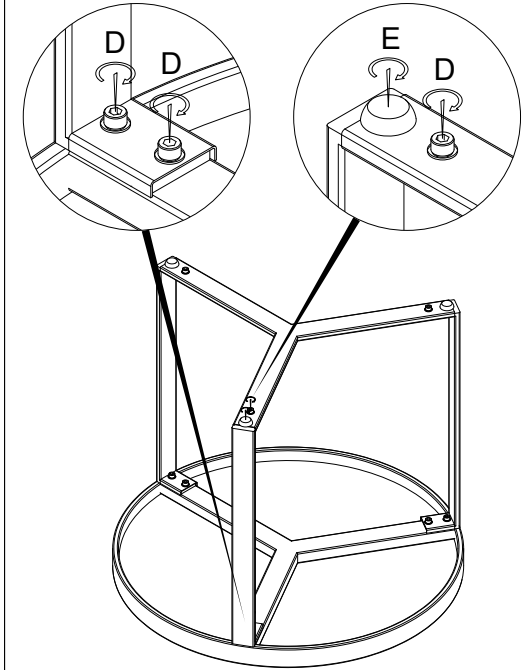

Step 9

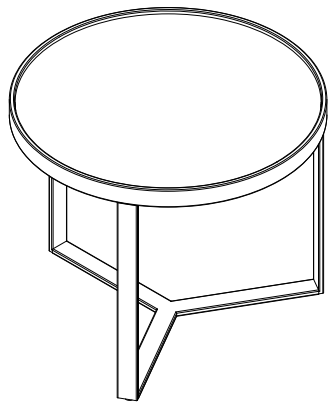

Tighten all screws and turn it over to finish