

**Bed**  
Lit  
Cama

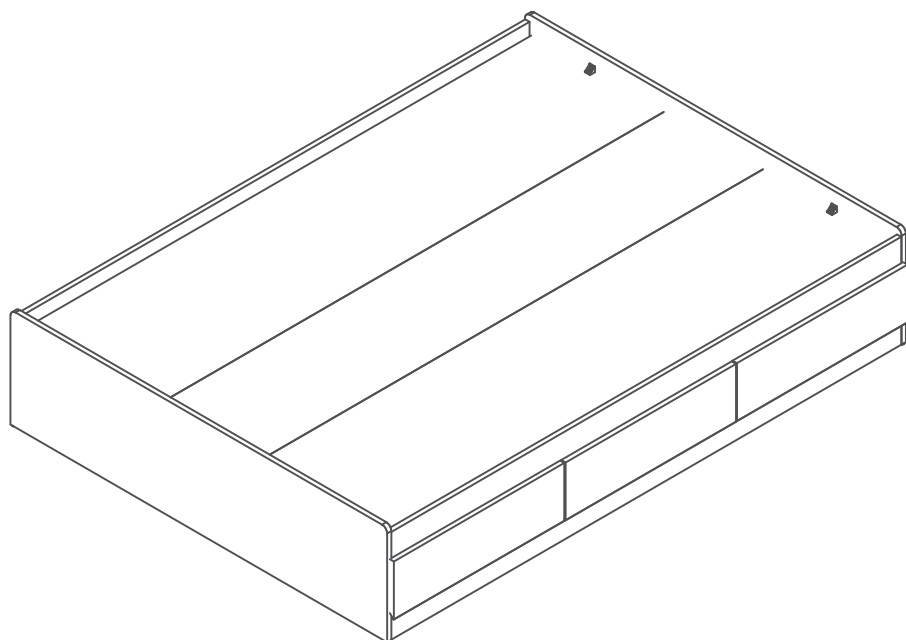

**Get ready for assembly!**  
**Préparez-vous à l'assemblage!**  
**Prepárese para el montaje!**



# WARRANTY / GARANTIE / GARANTÍA

## **5-year Warranty on furniture manufactured by us and 1 year warranty on other furniture and décor accesories.**

Our furniture is like family to us. And we never turn our back on family.

Our commitment to our furniture -- and to you -- doesn't end the minute you've purchased the piece. We offer a 5-year warranty on all of our manufactured furniture pieces.

1. We provides the original buyer with a warranty covering "defects" on furniture parts and workmanship for a period of 5 years from the date of purchase for products manufactured by us. We offer a 1-year warranty from the date of purchase to the original buyer on the products and decor accessories identified and presented with this warranty. The 1-year warranty covers defects on parts and workmanship.

2.The word defect" as used in this warranty is defined as any imperfection that may impair the use of the product for which it was intended.

3.This warranty is s trictly limited to the repair or replacement of defective components and parts. This warranty excludes all other direct or indirect charges and expenses according to the limit permitted by law in your state/province.

4.In the event can not replace a part its responsibility can not exceed the value or cost of production of that part or the replacement retail value of the defective item,

5.This warranty only applies under conditions of normal domestic use. It does not cover defects resulting from intentional damage, negligence, abuse, commercial use, product modification, accidents, exposure to the elements,or maintenance that does not comply with the guidelines in the assembly guide.

The warranties offered by us do not apply to the products of our partners on the Local showcase section of the web site ; each of those partners/ manufacturers sell its products on our web platform but offer its own warranty and details can be found on the product page of applicable products.

## **10-year Warranty on Workplace products BIFMA tested and 5-year / 2-year on height-adjustable working tables**

1. Our provides the original buyer with a warranty covering "defects" on furniture parts and workmanship for a period of 10 years from the date or purchase Workplace BIFMA tested products.

2. Our Furniture provides the original buyer of a height-adjustable table with a 5-year warranty from the date of purchase on the structure elements and a 2-year warranty on the electronic components. This warranty covers defects on parts and workmanship.

3. The word "defect" as used in this warranty is defined as any imperfection that may impair the use of the product for which it was intended.

4. This warranty is strictly limited to the repair or replacement of detective components and parts. This warranty excludes all other direct or indirect charges and expenses according to the limit permitted by law in your state/province.

5. In the event can not replace a part its responsibility can not exceed the value or cost of production of that part or the replacement retail value of the defective item,

6. This warranty only applies under conditions of normal use. It does not cover defects resulting from intentional damage, negligence, abuse, product modification, accidents,exposure to the elements, or maintenance that does not comply with the guidelines in the assembly guide.

7. When applying this warranty reserves the right to ask for the proof of purchase of the original buyer.

8. This warranty is only valid on purchases made at authorized retailers in Canada, the U.S.A. and Mexico.

## **30-day return policy on décor accessories**

If you are not completely satisfied with a non-furniture item you purchased, please contact us within 30 days of delivery to arrange for the exchange of, or a refund on, your unused item. We will send a courier over to take the item from your home. You will be charged a return shipping fee equal to 15% of the cost of the items returned. We reserves the right to refuse a return or an exchange if any condition is not met.

### **We do not accept:**

Returns unless the item is unused and in its original packaging.

Returns or exchanges on bedding (comforters, duvet covers, coverlets, bedsheets, pillows, duvets, and crib sets) that has been opened or used, or on any product that has been modified, altered or washed.

Returns on any mattress or stuffed/upholstered products without their legal label.

# 1

Let's get handy!

Mettons-nous au travail ! / ¡ Vamos a ponernos prácticos !

01



02



03



04



05



# 2

Collect the pieces together  
Rassembler les morceaux ensemble  
Poner las piezas juntas

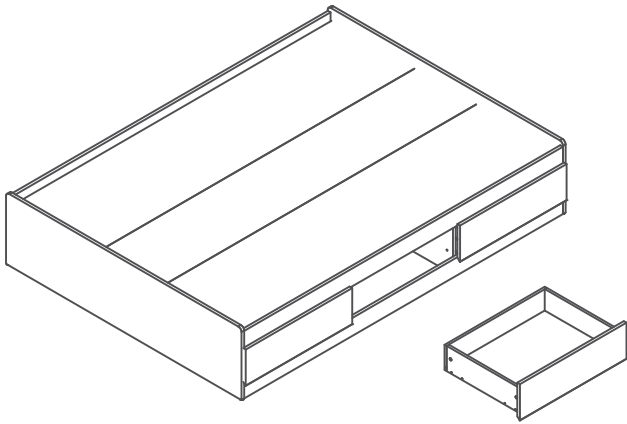

The image may differ depending on model  
L'image peut différer selon le modèle  
La imagen variar dependiendo del modelo

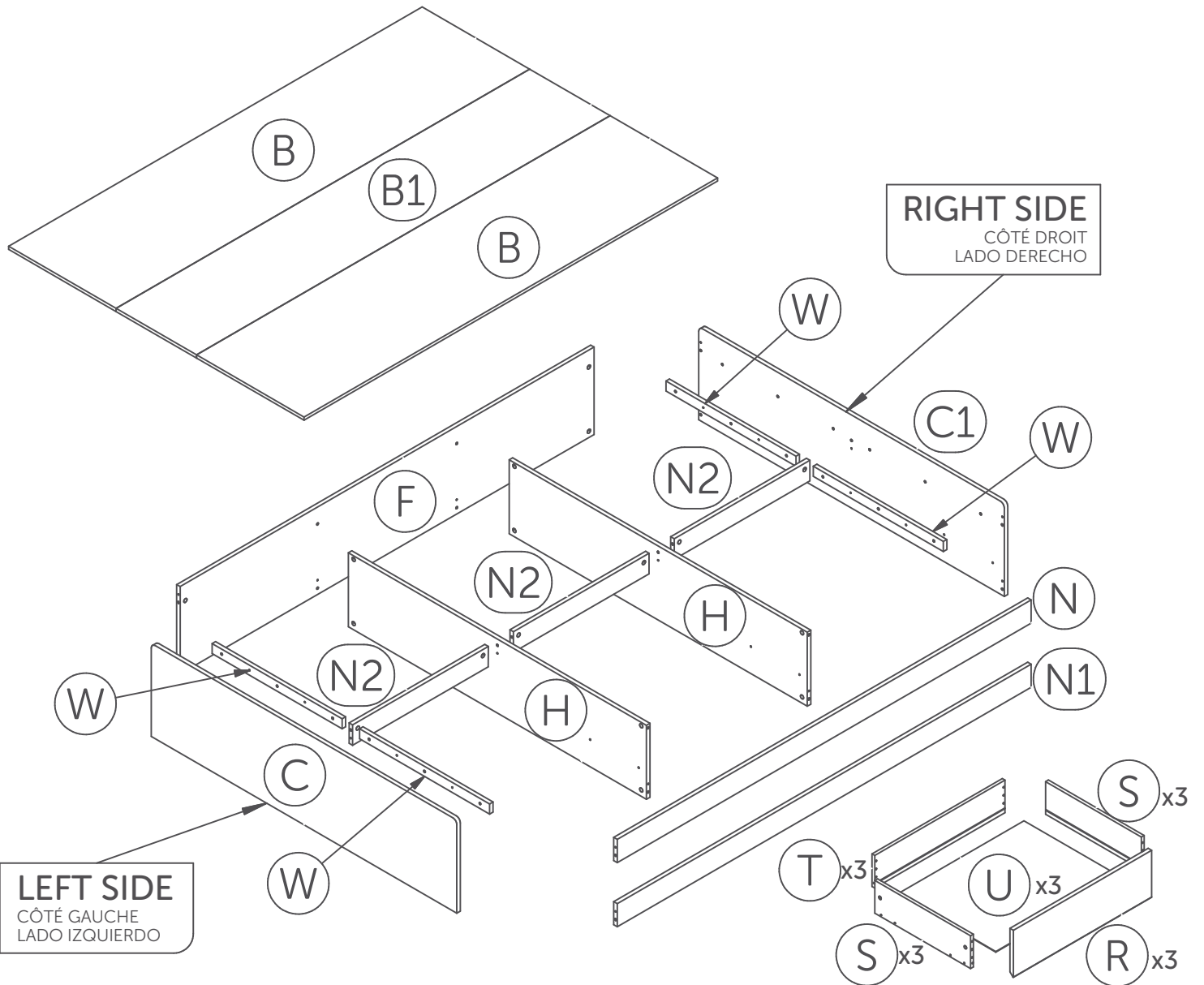

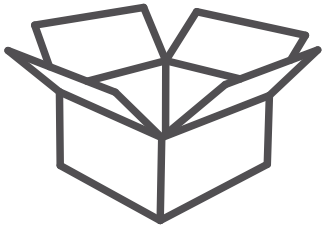

Box/Boîte/Caja #1  
C-C1-H(2)-N2(3)-  
R(3)-S(6)-T(3)-W(4)

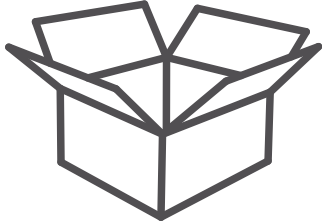

Box/Boîte/Caja#2  
B(2)-B1-F-N-N1-U(3)

The image may differ depending on model  
L'image peut différer selon le modèle  
La imagen variará dependiendo del modelo

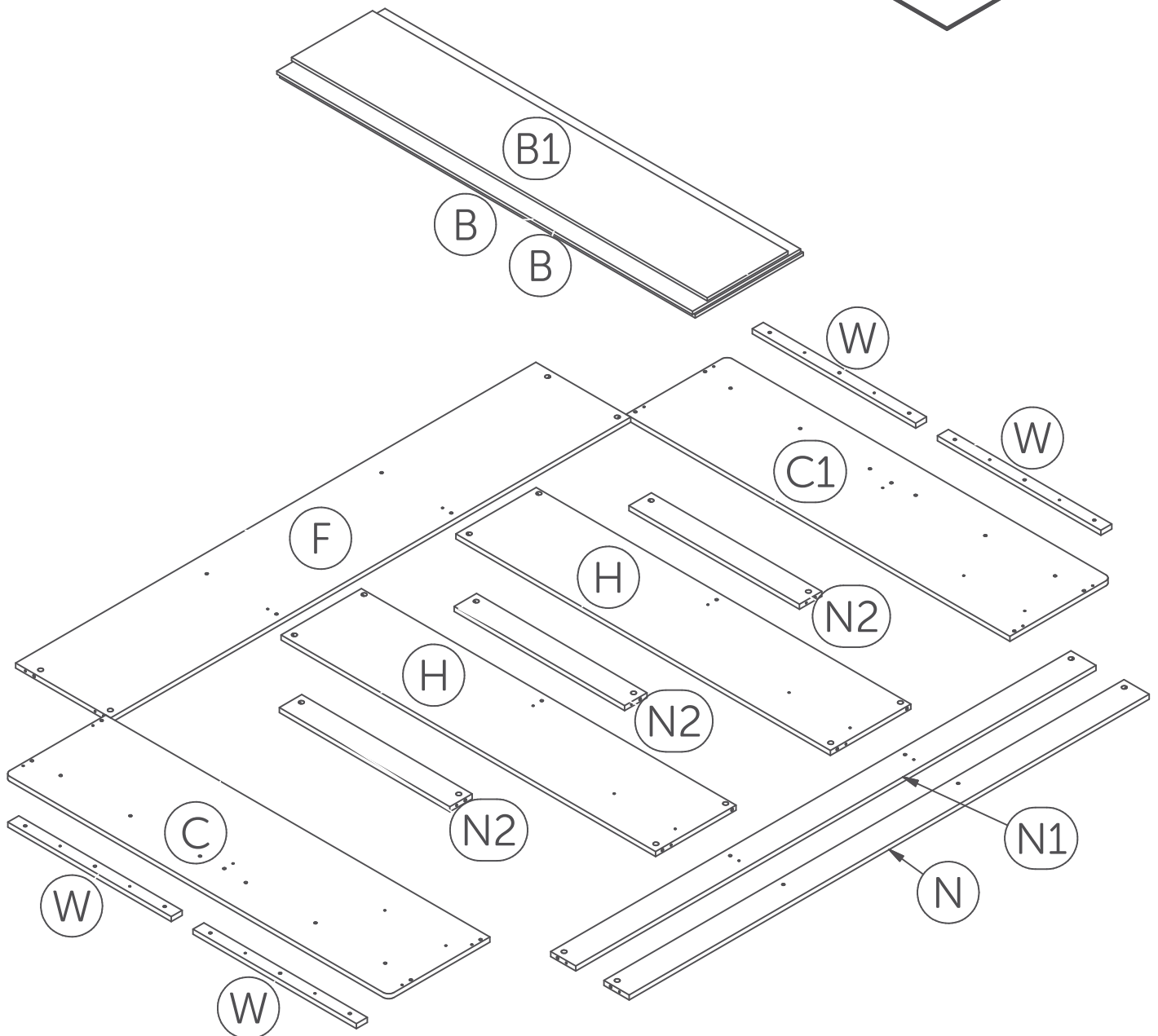
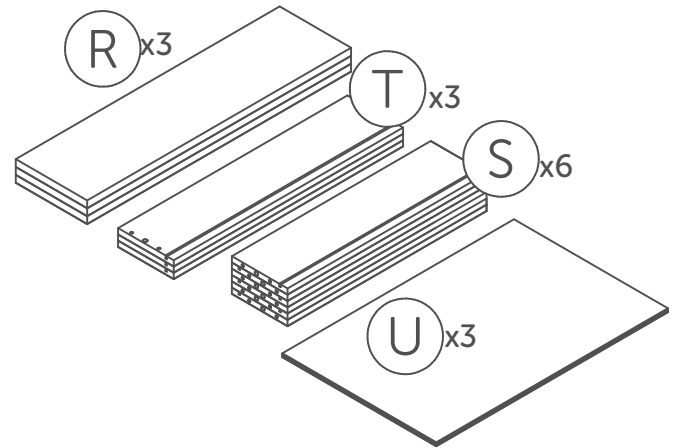

# 3

## Collect the hardware Rassembler la quincaillerie Reunir los artículos de ferretería

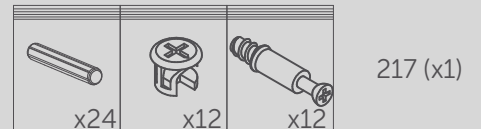
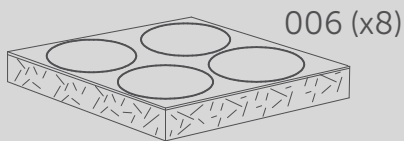
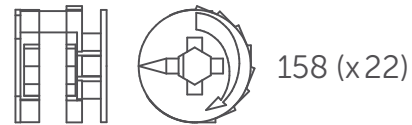
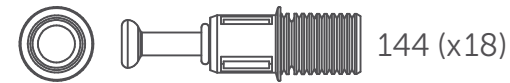
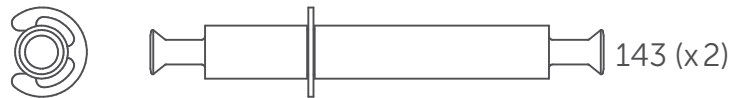
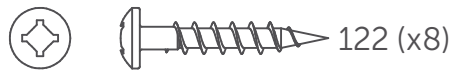
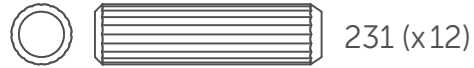
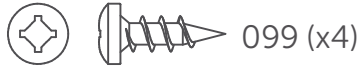

For drawers only/Pour tiroir seulement/  
Solamente para cajones

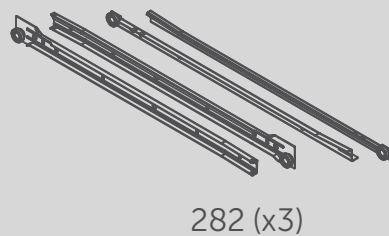
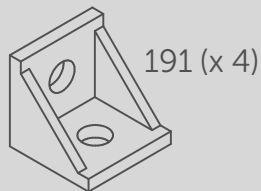

\*Hardware package may have spare parts.  
\*Le sac de quincaillerie peut contenir des pièces de remplacement.  
\*La bolsa de herraje puede contener piezas adicionales de repuesto.

# 4

Collect the hardware by model

Rassembler la quincaillerie selon le modèle

Reunir los artículos de ferretería según el modelo

1 : 1



059 (x6)



695 (x6)



461 (x3)

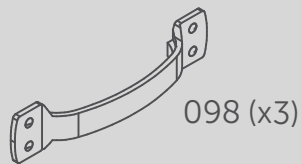

098 (x3)



380 (x3)



277 (x3)

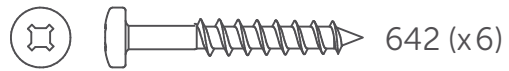

642 (x6)

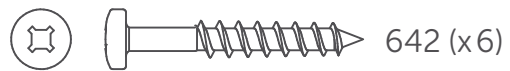

642 (x6)

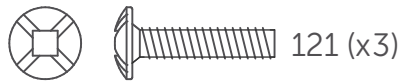

121 (x3)



135 (x6)

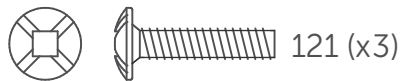

121 (x3)



377 (x3)

# 5

## Things to remember for assembly

À retenir lors de l'assemblage

A recordar durante el ensamblaje

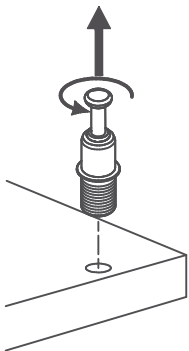
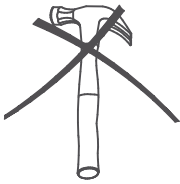
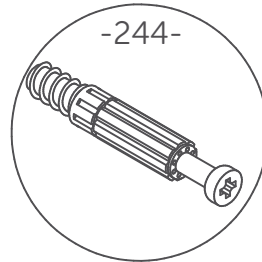
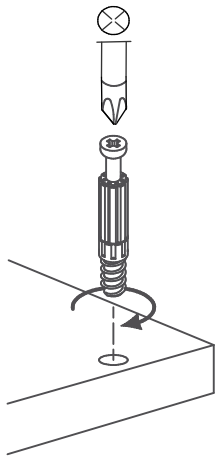
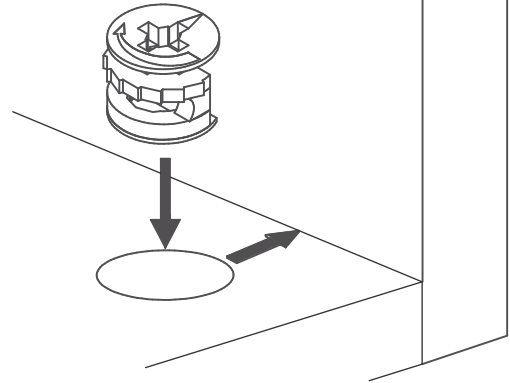
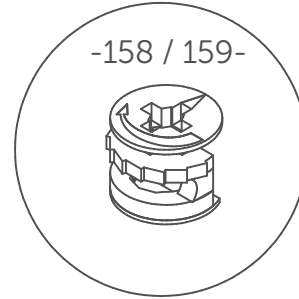
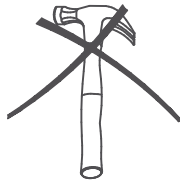
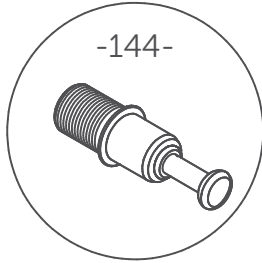
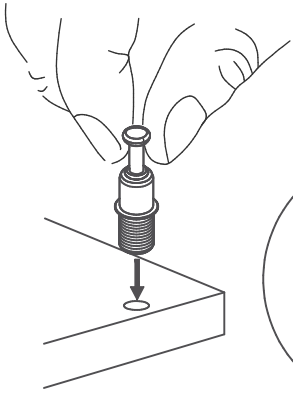

To remove: Twist and pull  
Pour enlever: Tourner et tirer  
Para retirar: Girar y tirar

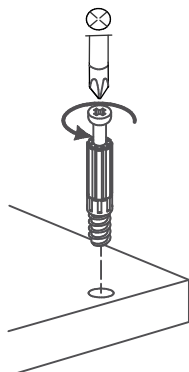
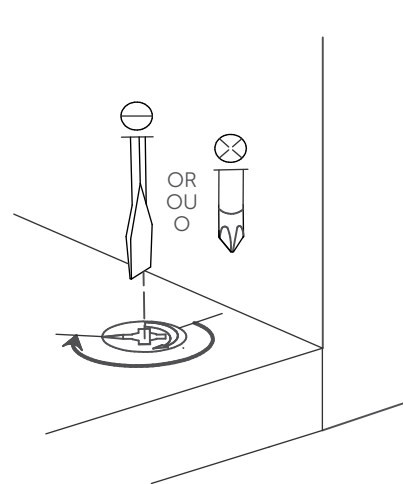

To remove: unscrew  
Pour enlever: dévisser  
Para retirar: desatornillar

Screw past the halfway point  
Visser plus qu'un demi tour  
Atornillar más de media vuelta

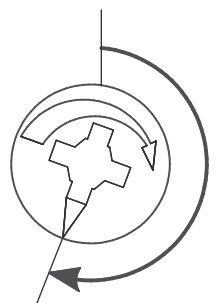

# 6

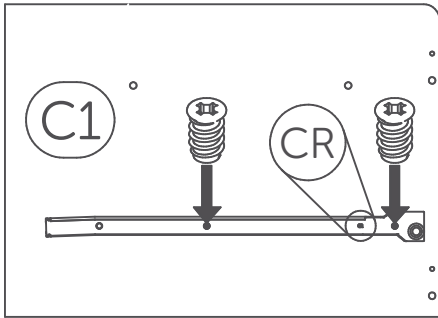

Assembly  
Assemblage  
Ensambladura  
Box/Boîte/Caja #1

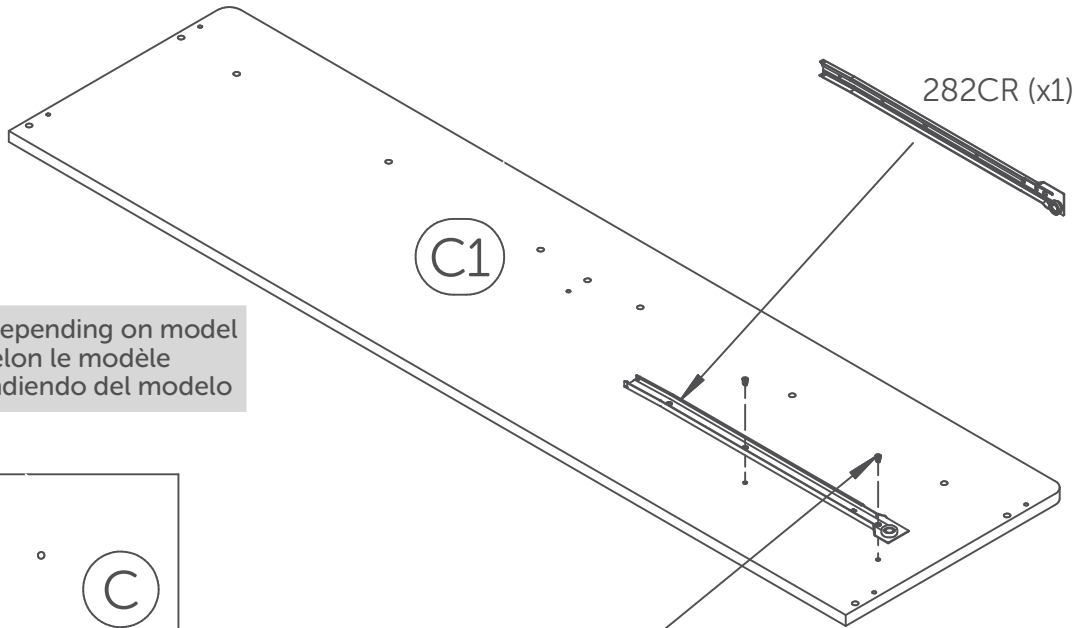

The image may differ depending on model  
L'image peut différer selon le modèle  
La imagen variar dependiendo del modelo

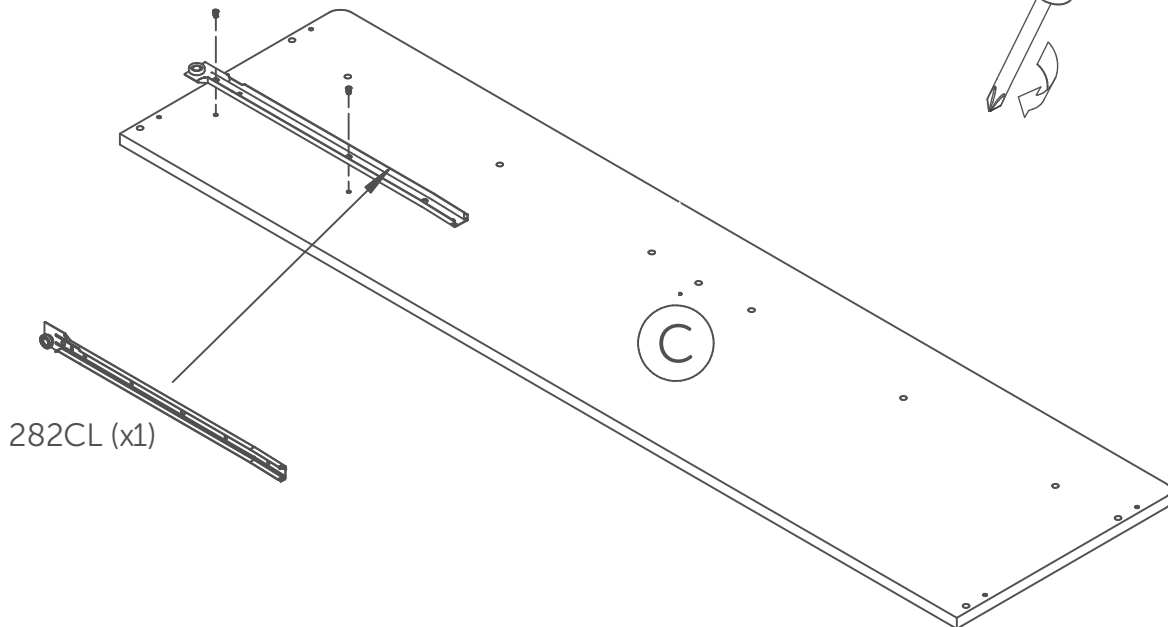
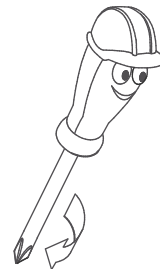
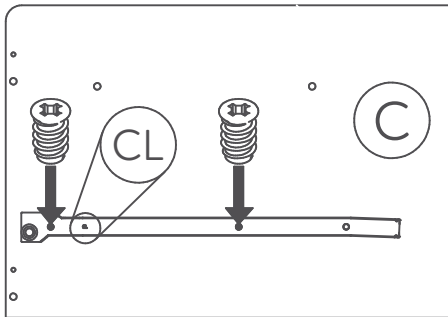

7

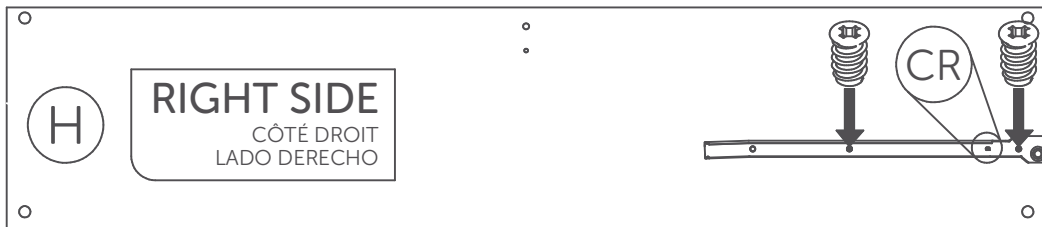
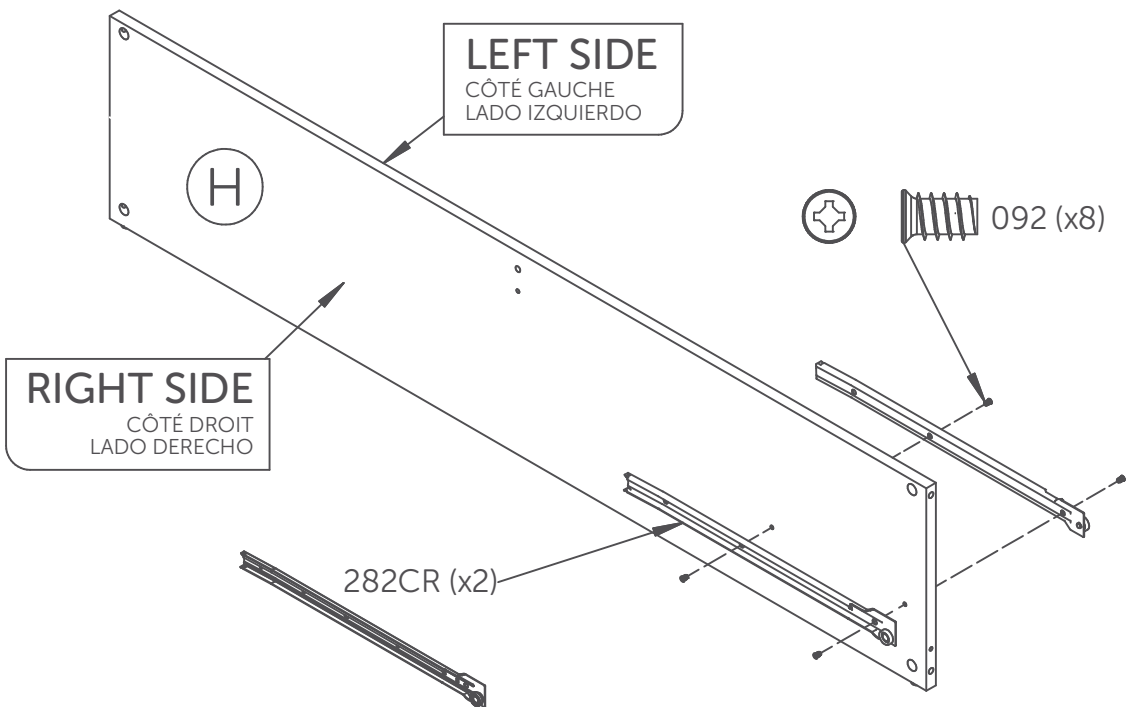
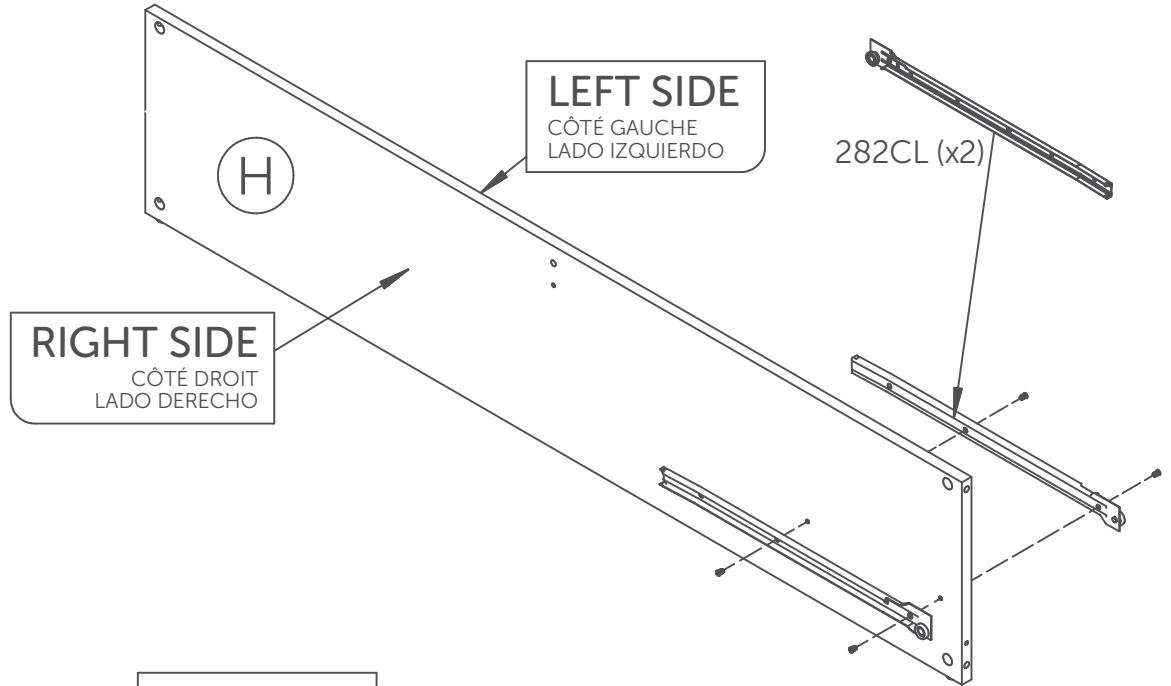
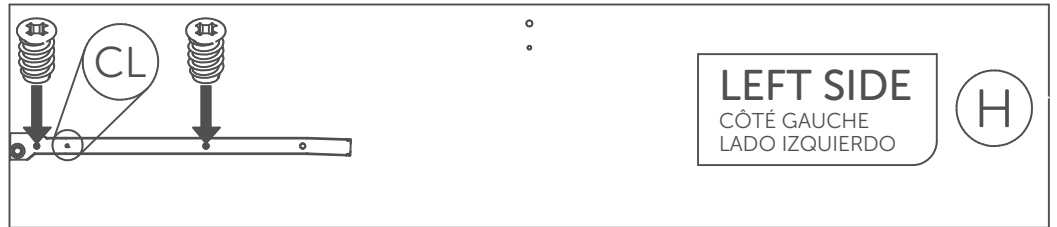

# 8

## 8.1

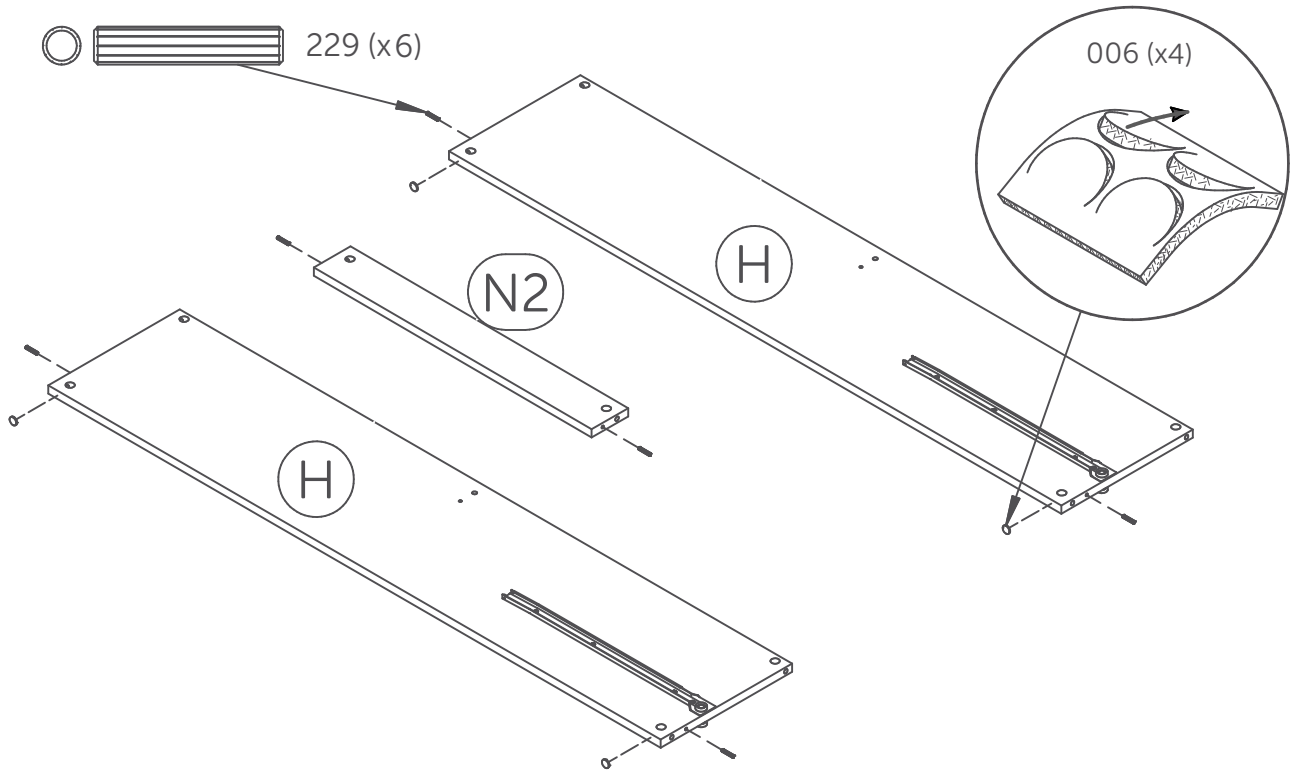

## 8.2

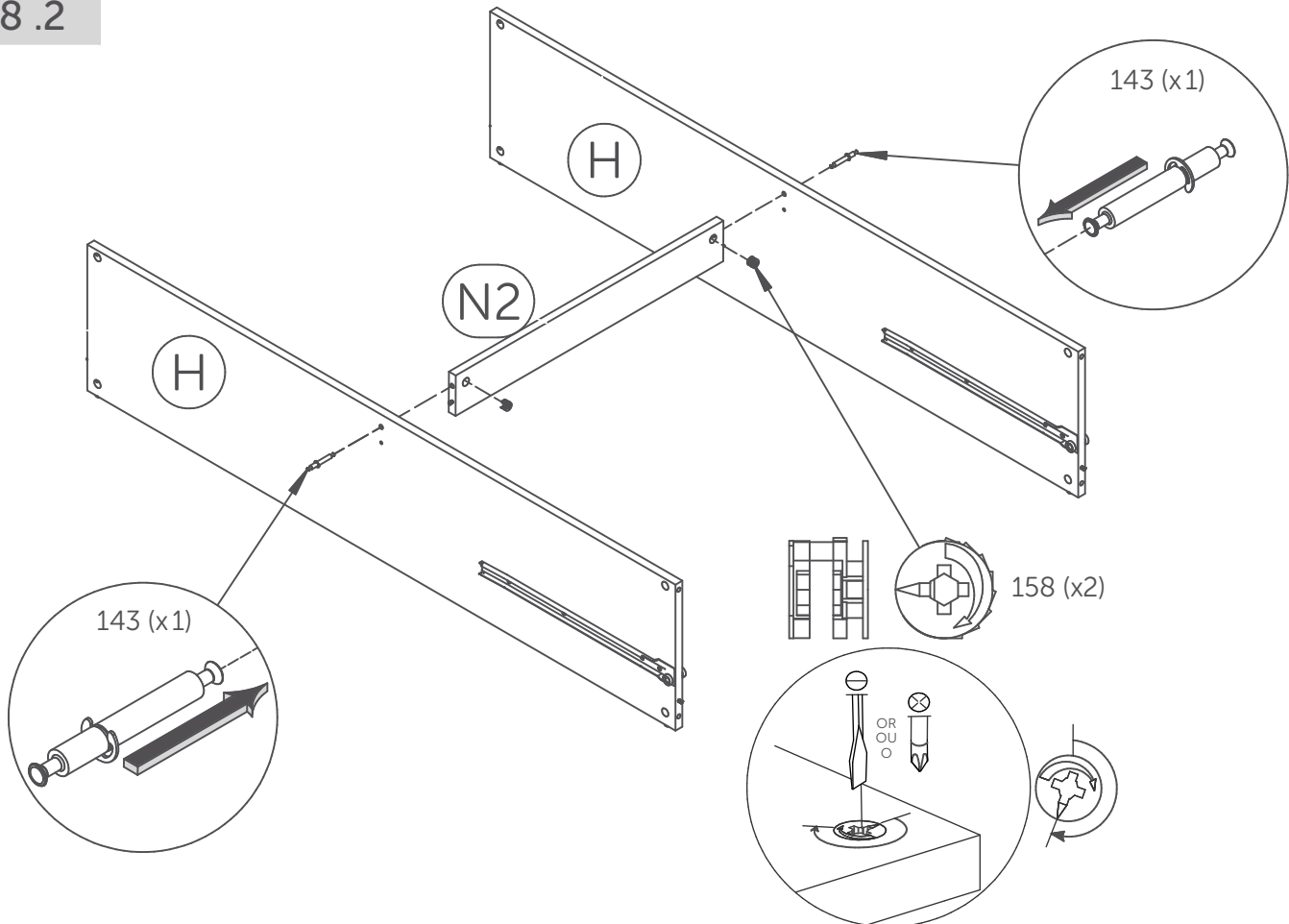

Screw pass the half way point  
Visser plus qu'un demi tour

9

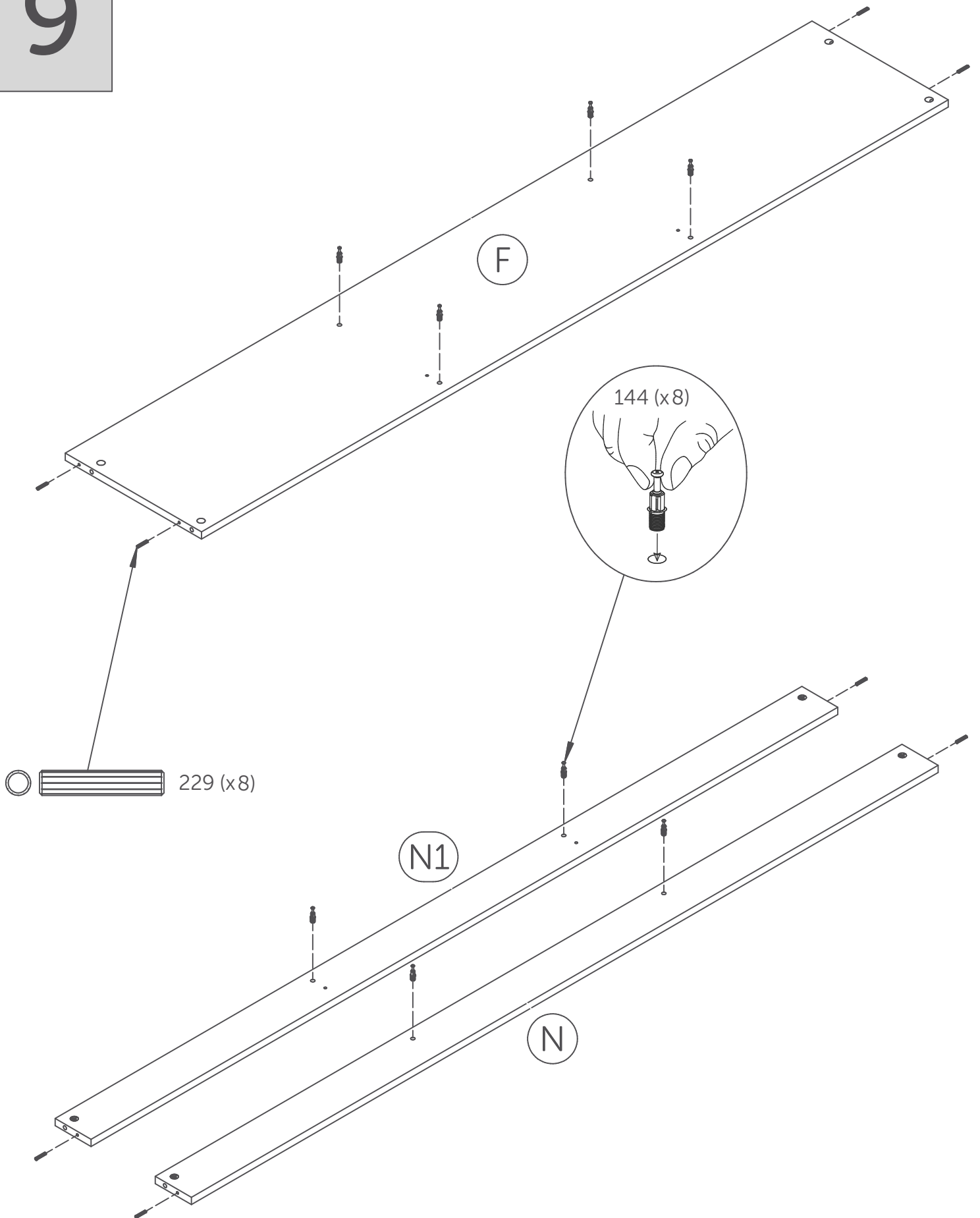

# 10

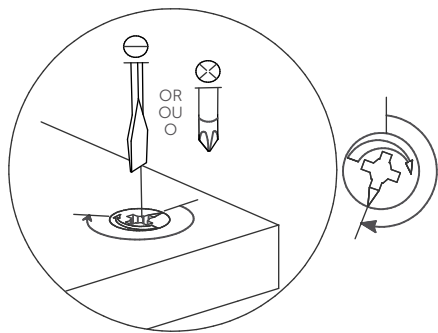
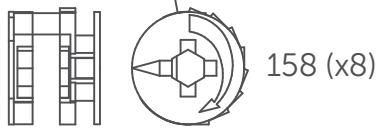
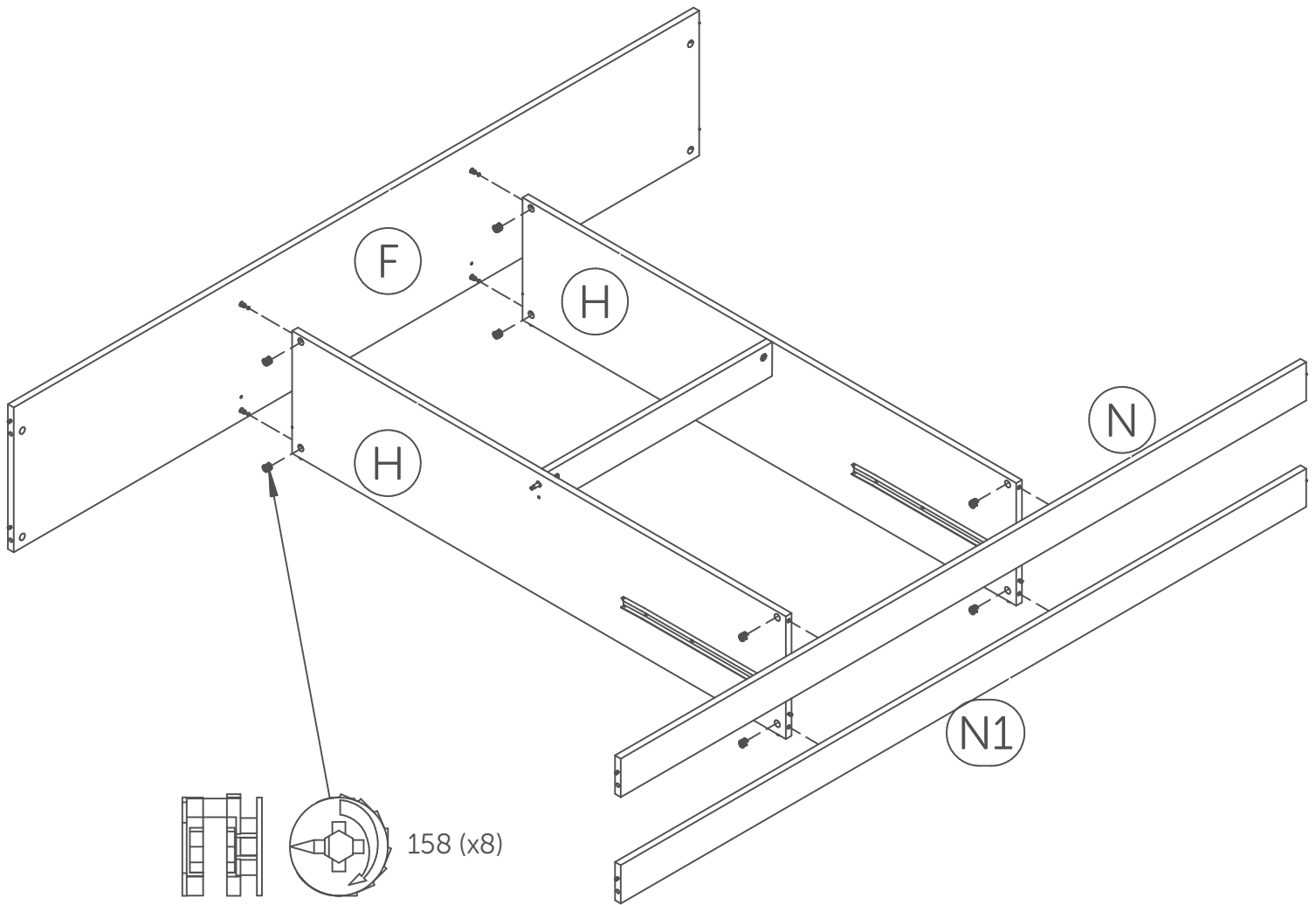

Screw pass the half way point  
Visser plus qu'un demi tour

11

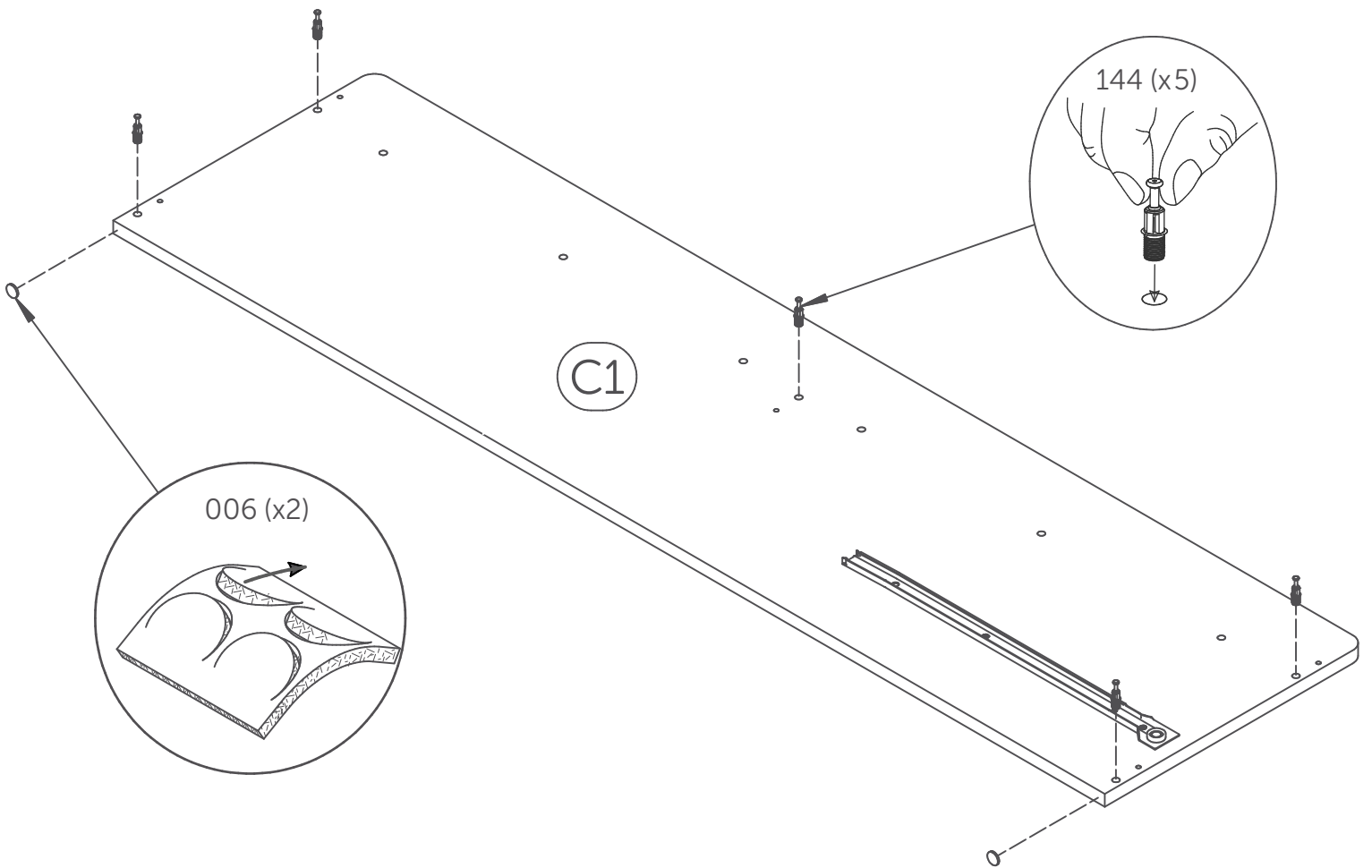

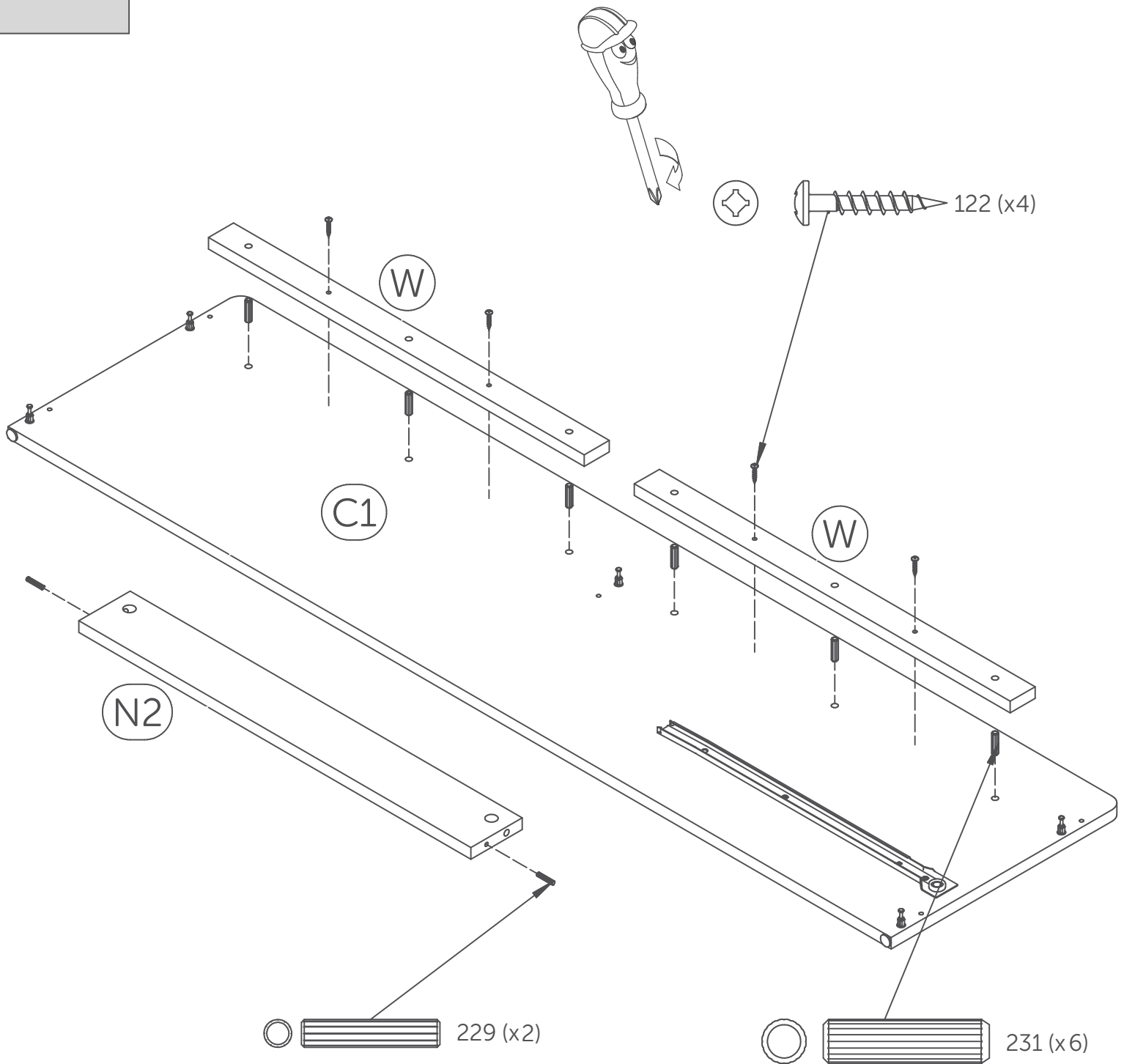

The image may differ depending on model  
L'image peut différer selon le modèle  
La imagen variar dependiendo del modelo

The image may differ depending on model  
L'image peut différer selon le modèle  
La imagen variar dependiendo del modelo

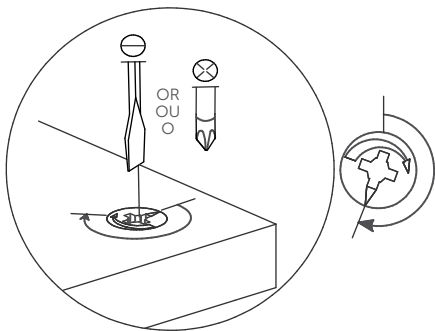
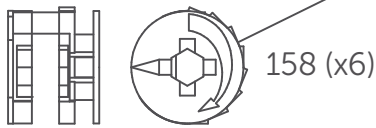
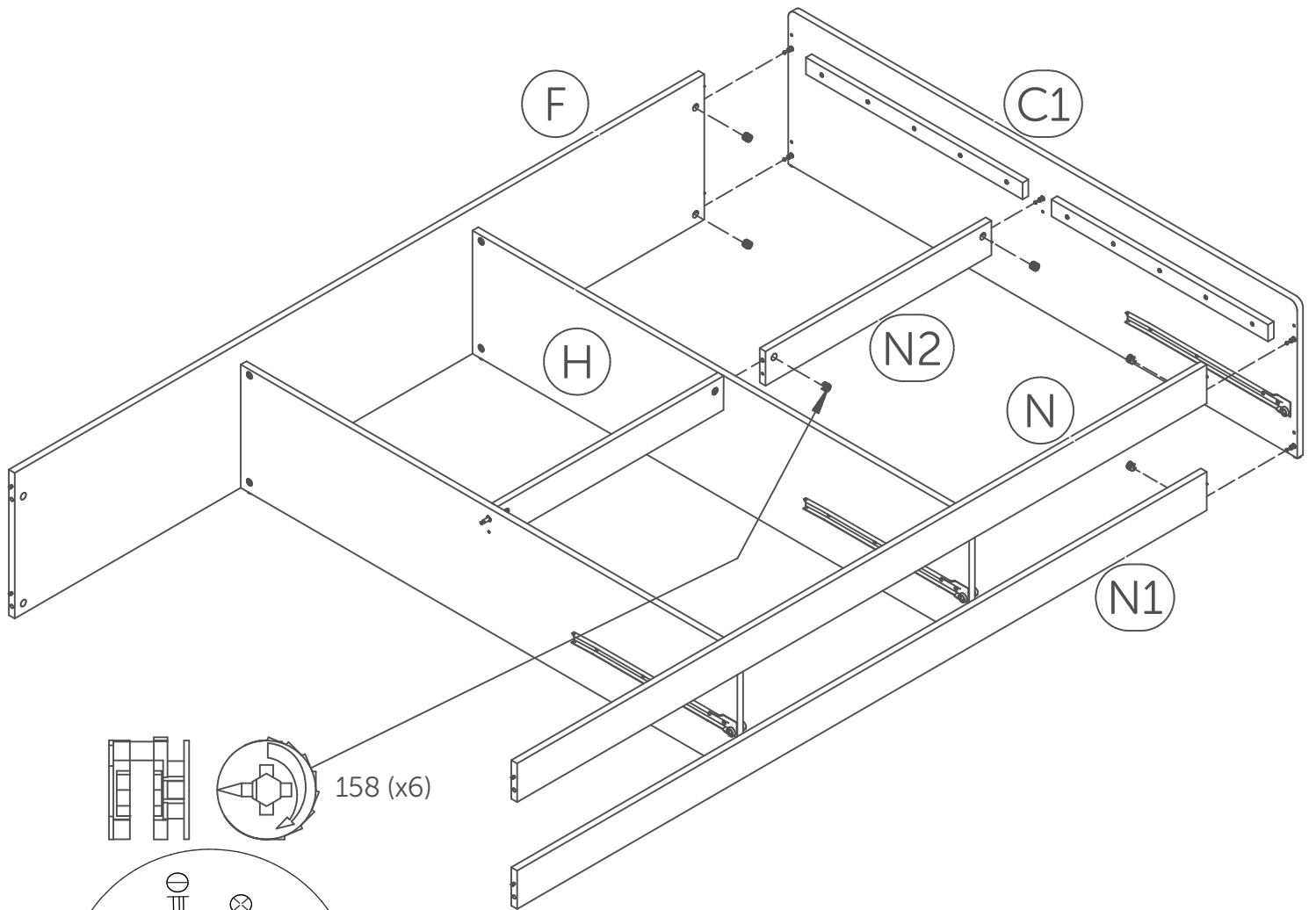

Screw pass the half way point  
Visser plus qu'un demi tour



# 15

The image may differ depending on model  
L'image peut différer selon le modèle  
La imagen variar dependiendo del modelo

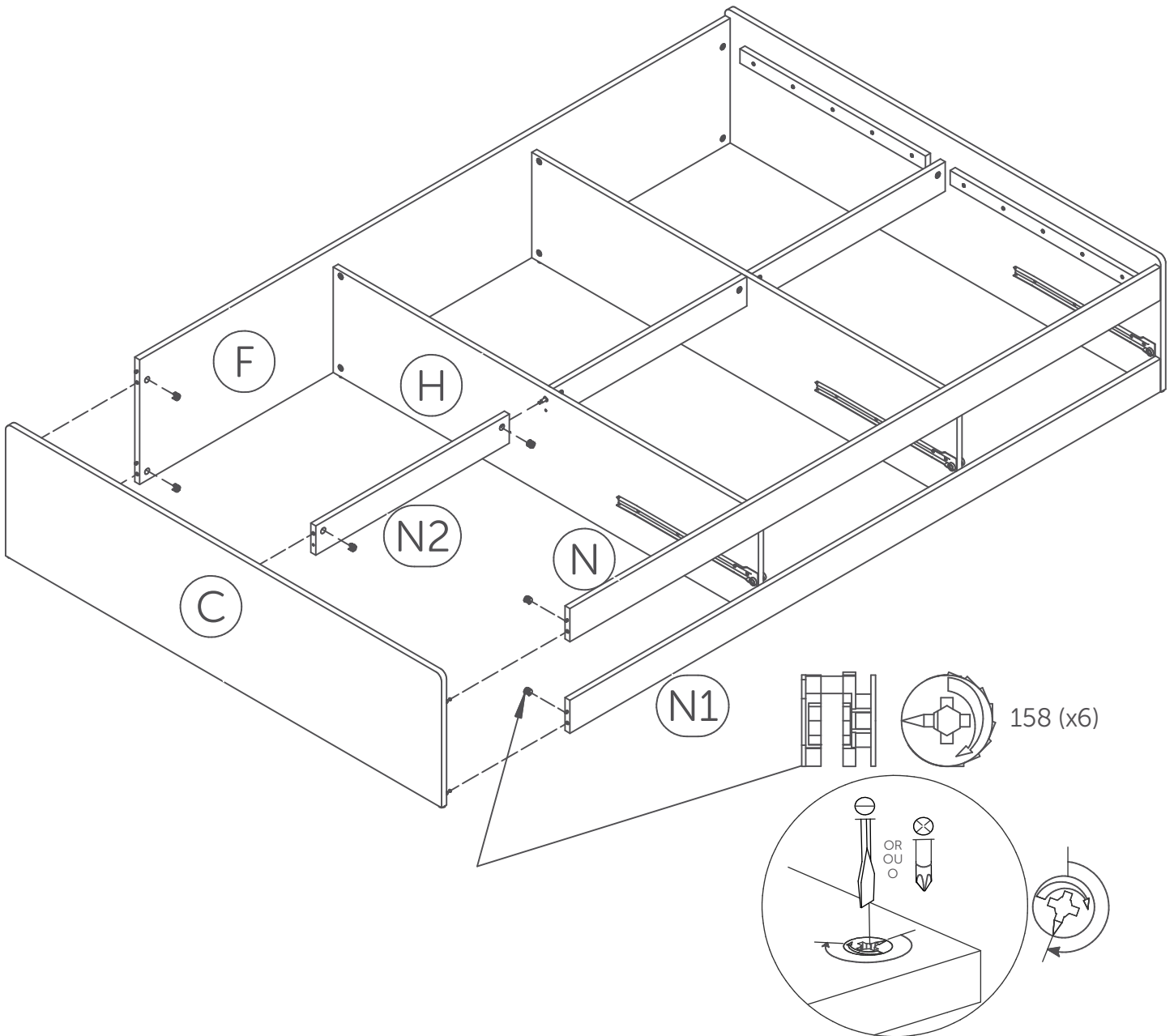

Screw pass the half way point  
Visser plus qu'un demi tour

# 16

Assembly  
Assemblage  
Ensambladura  
Box/Boîte/Caja #2

## 16.1

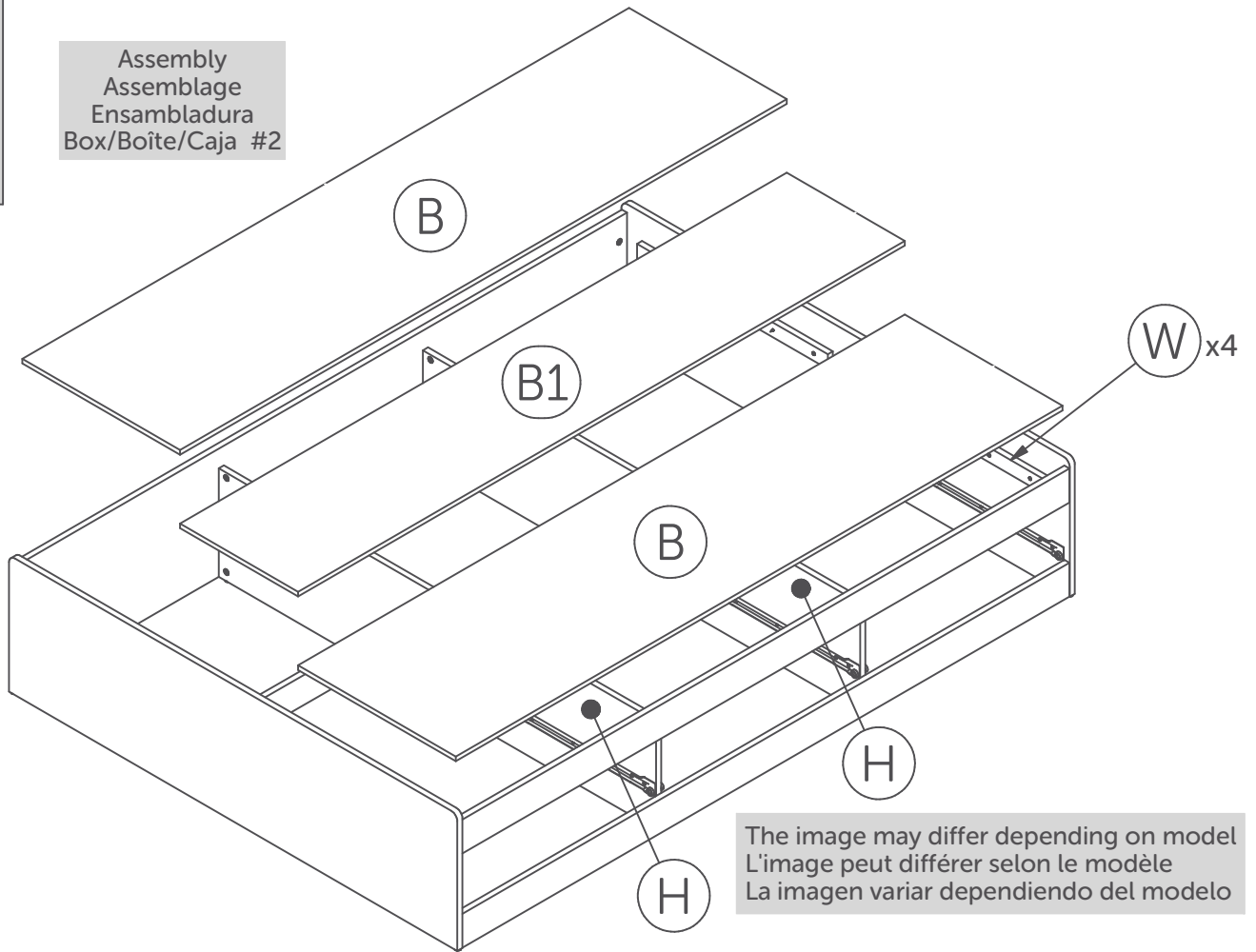

## 16.2

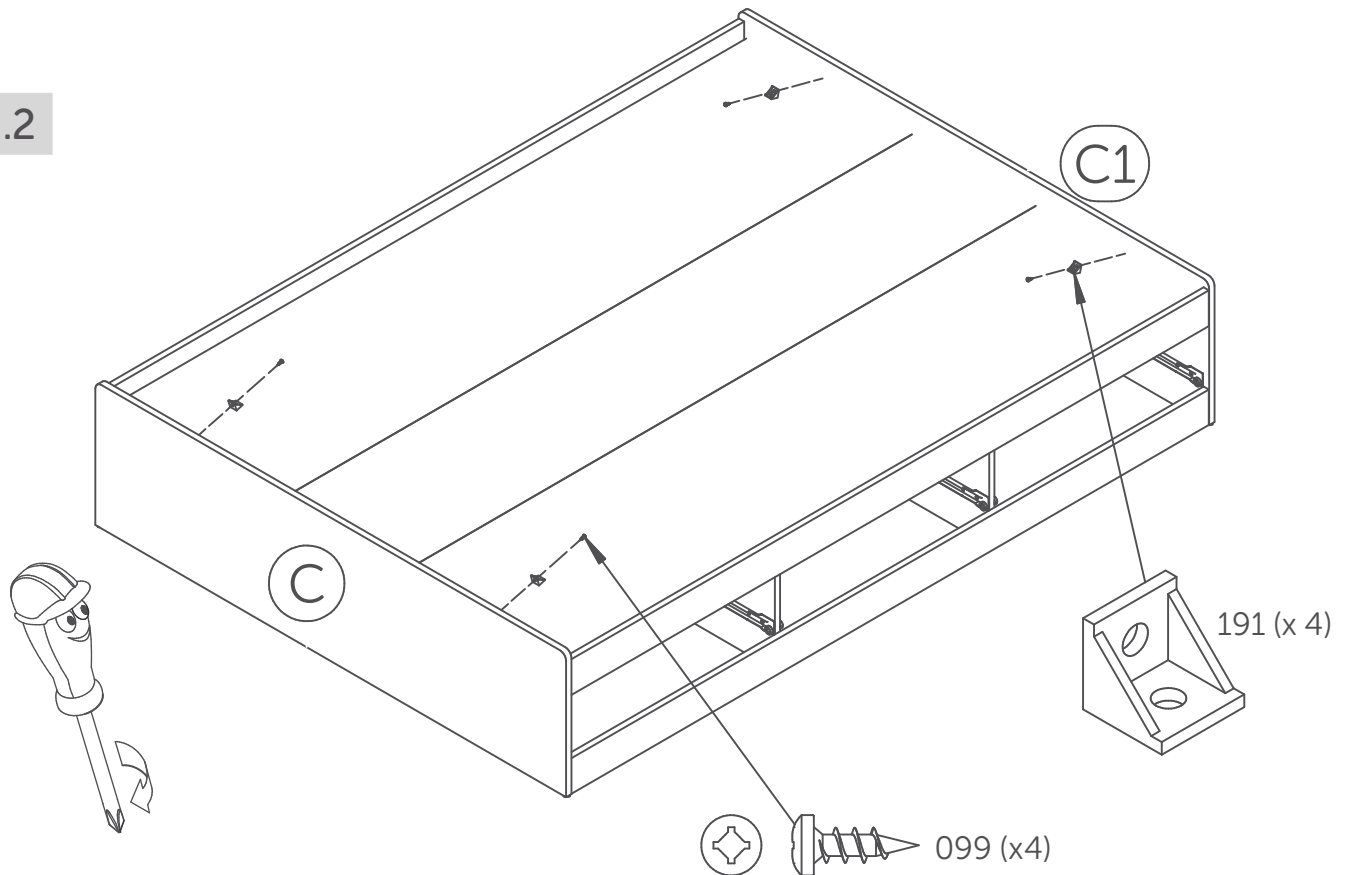

# 17

The image may differ depending on model  
L'image peut différer selon le modèle  
La imagen variará dependiendo del modelo

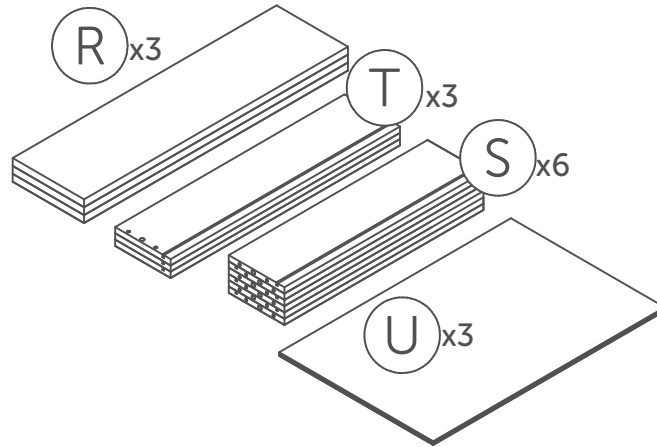

## 217

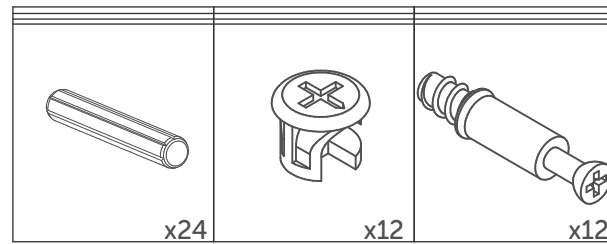

## 3x Drawers Tiroirs Cajones

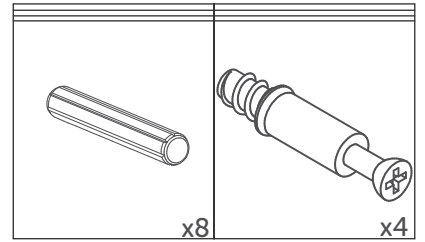
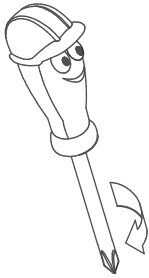

hardware needed for one drawer  
Quincaillerie nécessaire pour un tiroir  
Ferratería necesaria por cajón

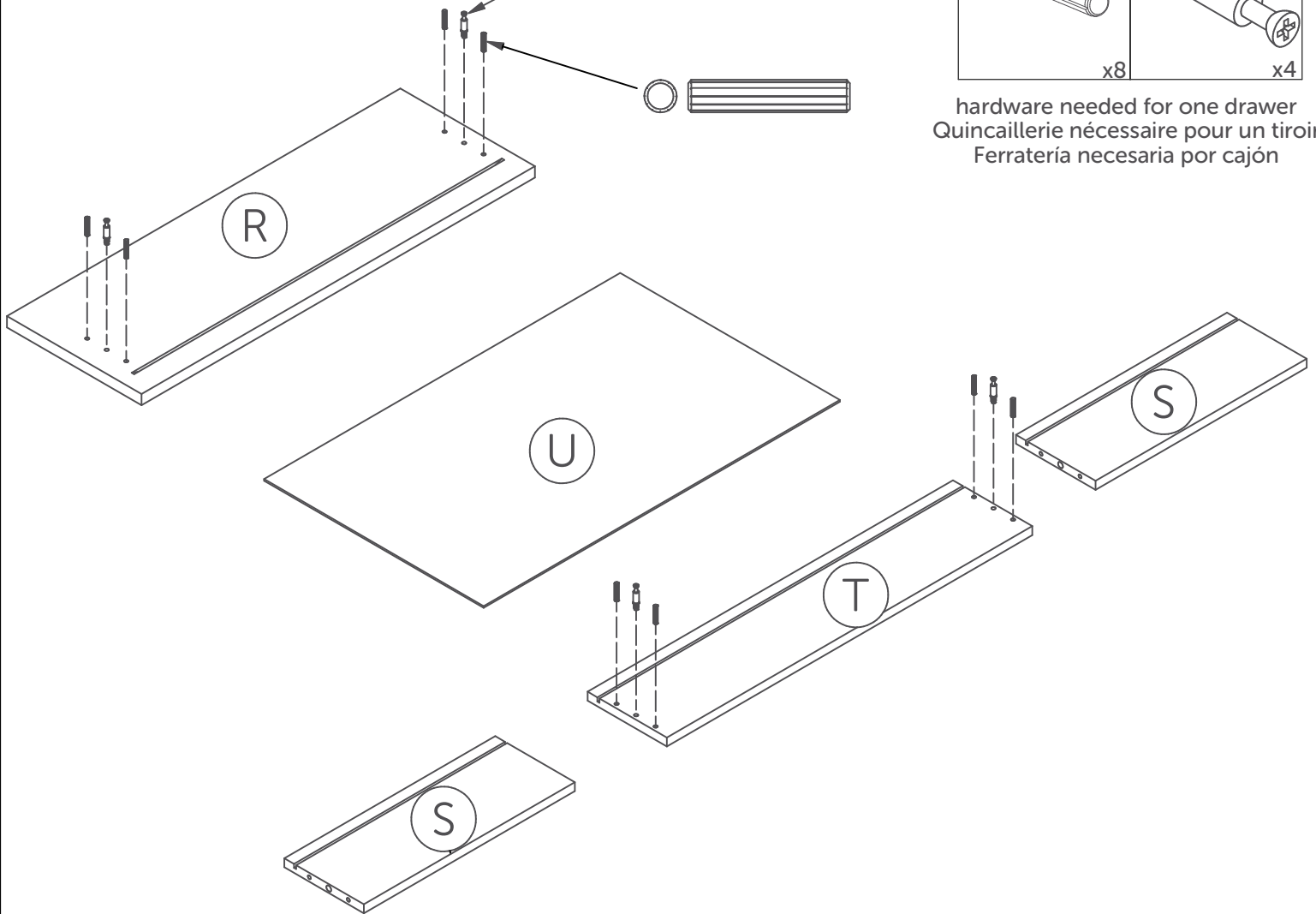

The image may differ depending on model  
L'image peut différer selon le modèle  
La imagen variar dependiendo del modelo

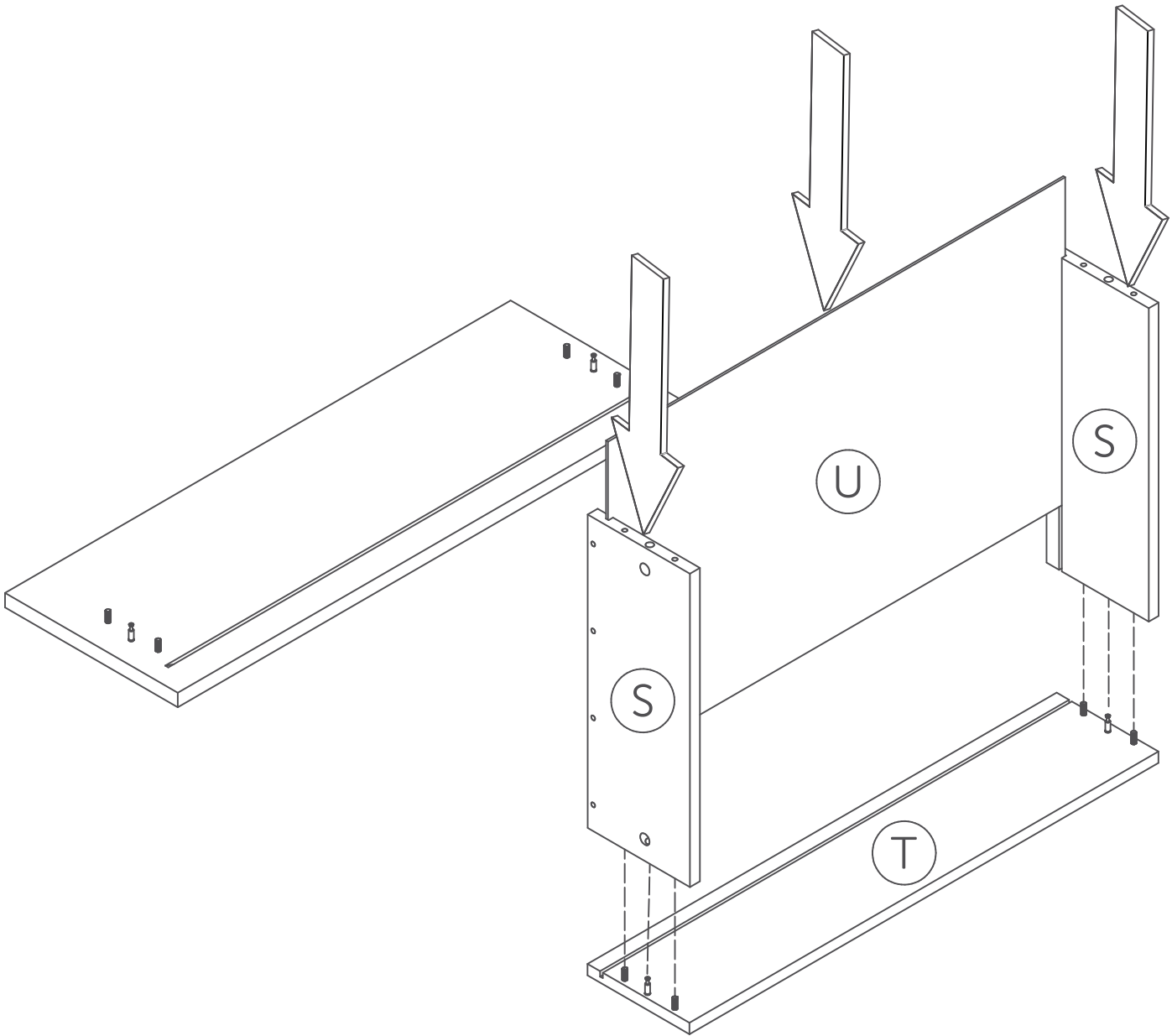

The image may differ depending on model  
L'image peut différer selon le modèle  
La imagen variar dependiendo del modelo

20

3x Drawers  
Tiroirs  
Cajones

The image may differ depending on model  
L'image peut différer selon le modèle  
La imagen variar dependiendo del modelo

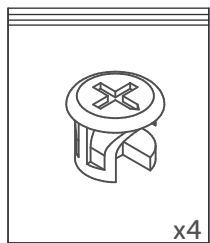
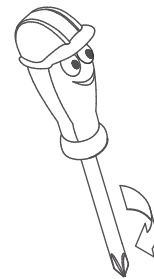
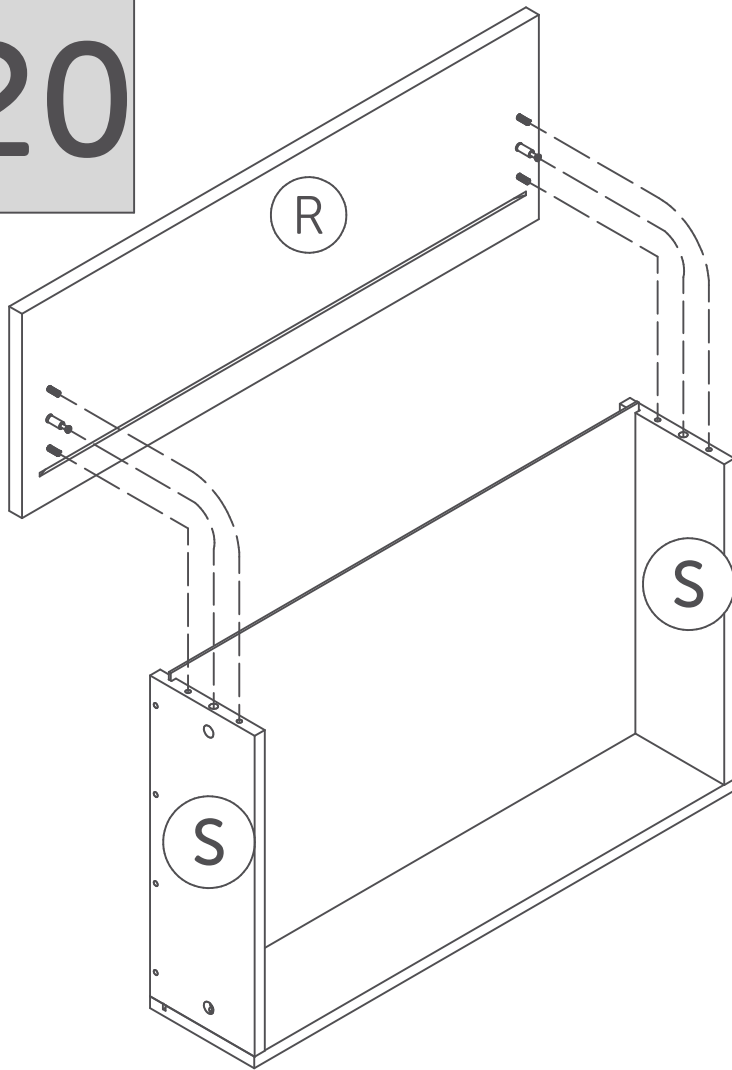

hardware needed for one drawer  
Quincaillerie nécessaire pour un tiroir  
Ferratería necesaria por cajón

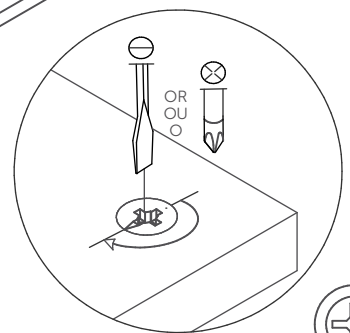
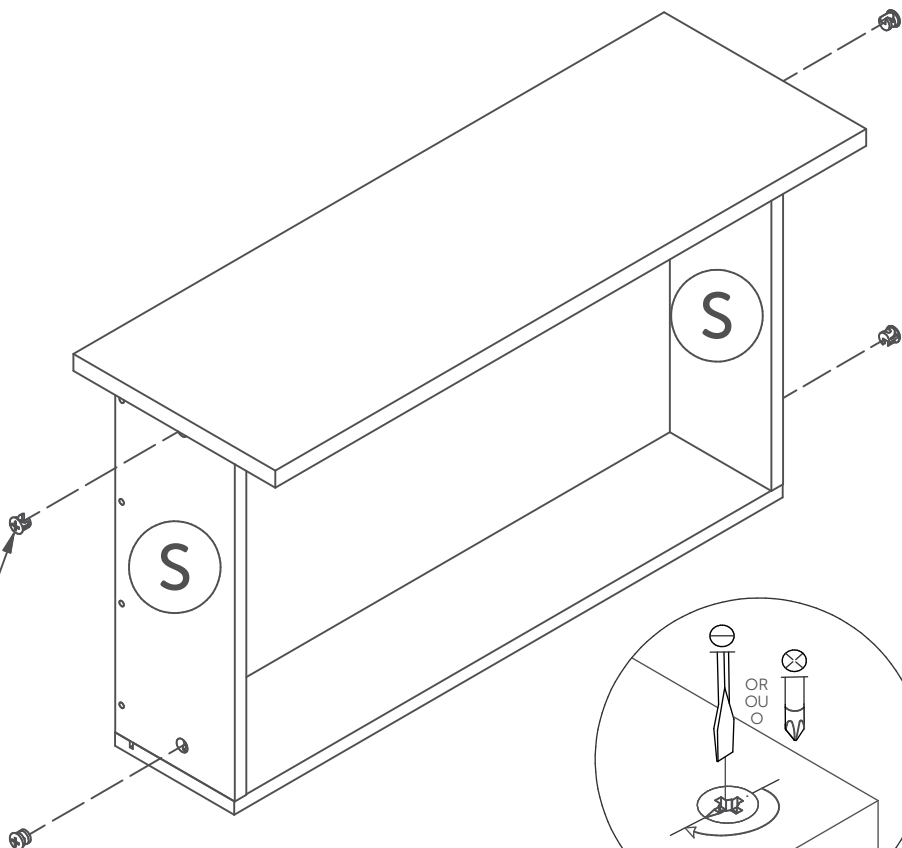

# 21

**3x** Drawers  
Tiroirs  
Cajones

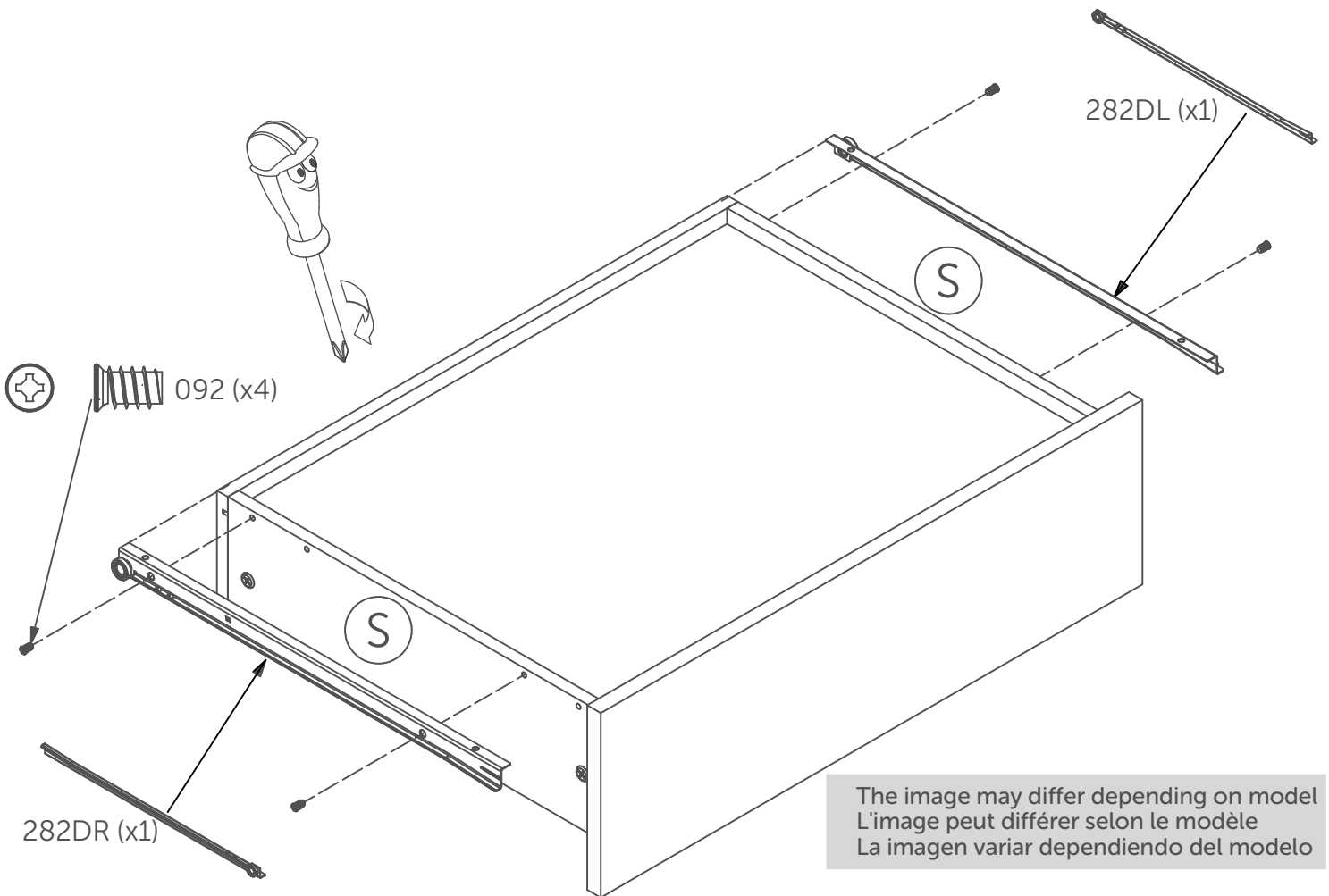

## HANDLE INSTALLATION INSTALLATION DES POIGNÉES INSTALACIÓN DE MANILLA

Depending of the type of screw and handle/button you have in your hardware bag, assemble the handle/button to the front of the drawer R.

Selon le type de vis de poignée/bouton que vous avez dans votre sac de quincaillerie, assembler la poignée/bouton à l'avant du tiroir R.

Dependiendo del tipo de tornillo y de manilla/perilla que tiene en su bolsa de herramientas, montar la manilla/perilla en la parte delantera del cajón R.

**metal / métal / metal**

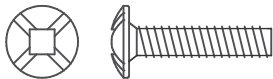

**handle / poignée / manilla**

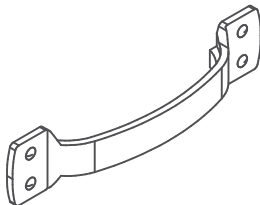

**wood / bois / mandera**

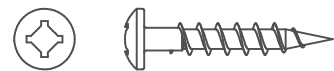

**knob / bouton / perilla**

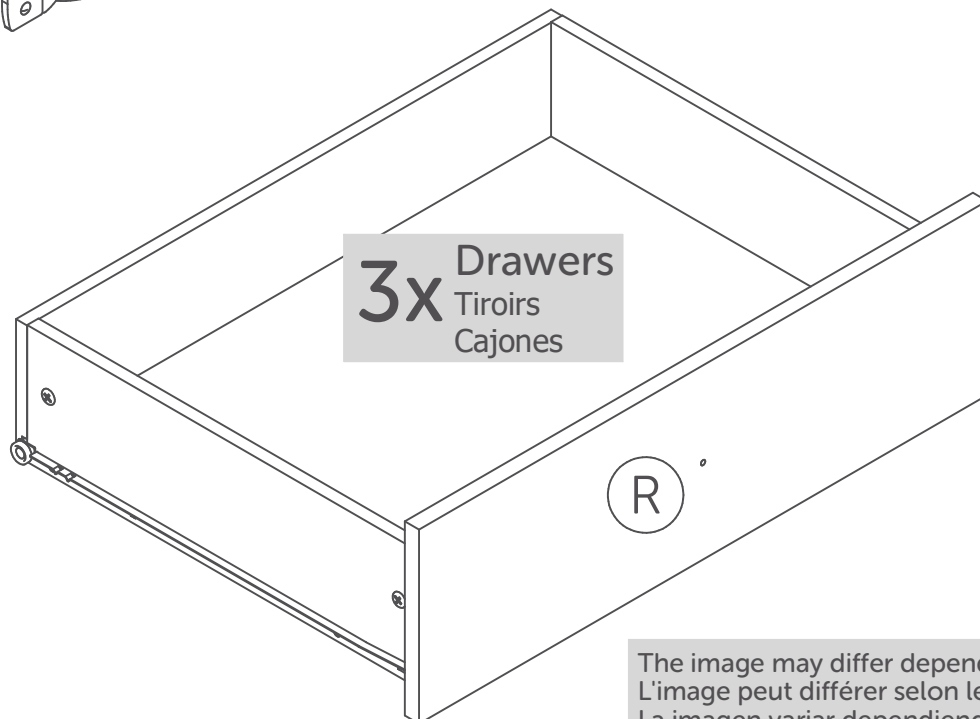

The image may differ depending on model  
L'image peut différer selon le modèle  
La imagen variar dependiendo del modelo

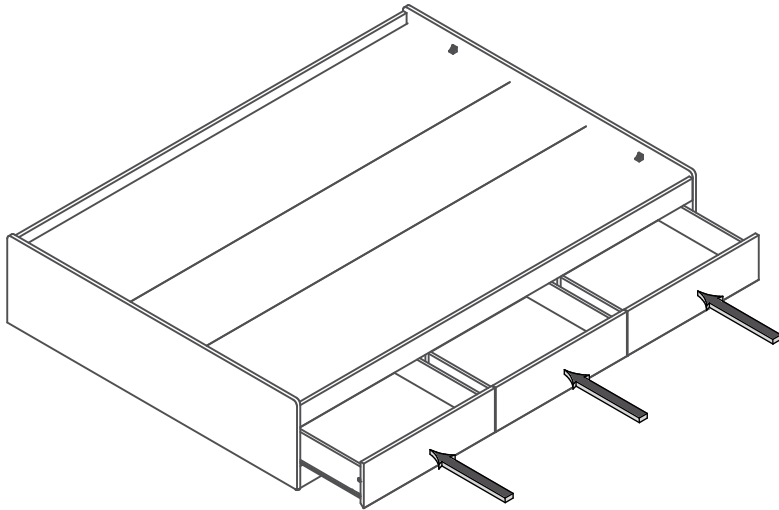

The image may differ depending on model  
L'image peut différer selon le modèle  
La imagen variará dependiendo del modelo

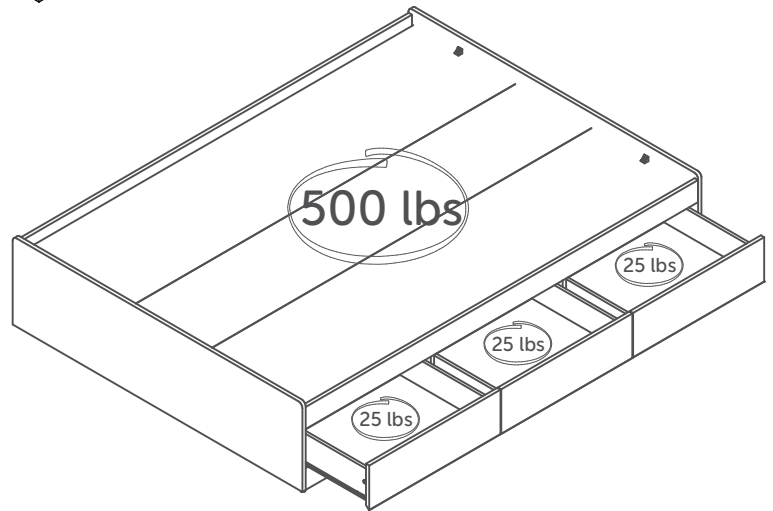

## MAINTENANCE TIPS CONSEILS D'ENTRETIEN / CONSEJOS DE MANTENIMIENTO



Never let liquids or damp cloths sit on this furniture.

Ne jamais laisser de liquide ou linge humide sur le meuble.

Nunca deje un líquido o un trapo húmedo sobre el mueble.



Never use chemical cleaning products. They can damage the finish.  
For cleaning, use only a slightly damp cloth and wipe dry.

Ne jamais utiliser de produits nettoyants à base de produits chimiques, cela va endommager le fini. Utiliser seulement un linge légèrement humide.

Nunca utilice limpiadores a base de químicos, estos dañaran le acabado. Use sólo un paño húmedo.

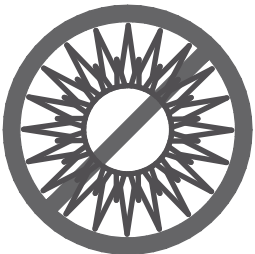

To avoid dulling of the finish, do not place furniture in direct sunlight.

Ne pas placer le meuble directement au soleil pour prévenir le ternissement.

No exponga el mueble directamente al sol para prevenir empañamiento.

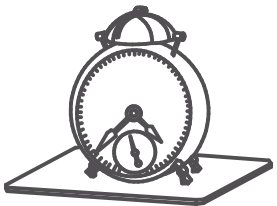

Do not put plastic or rubber rings under appliances. Use cloth or felt protectors.

Évitez de déposer des appareils avec des rondelles de plastique ou de caoutchouc.  
Utilisez un protecteur en tissu ou en feutre.

Evite apoyar aparatos con redondeles de plástico o de goma. Utilizar un protector de tela o de fieltro.



To clean, use a soft or slightly damp cloth, then wipe with a clean, dry cloth.

Pour nettoyer, utilisez un linge doux ou légèrement humecté.  
Essuyez par la suite avec un linge propre et sec.

Para limpiar, utilice un trapo suave o ligeramente humedecido.  
Seque luego con un trapo limpio y seco.

# Headboard

Tête de lit /Cabecera



## ASSEMBLY INSTRUCTIONS

INSTRUCTIONS D'ASSEMBLAGE / INSTRUCTIVO DE ARMADO

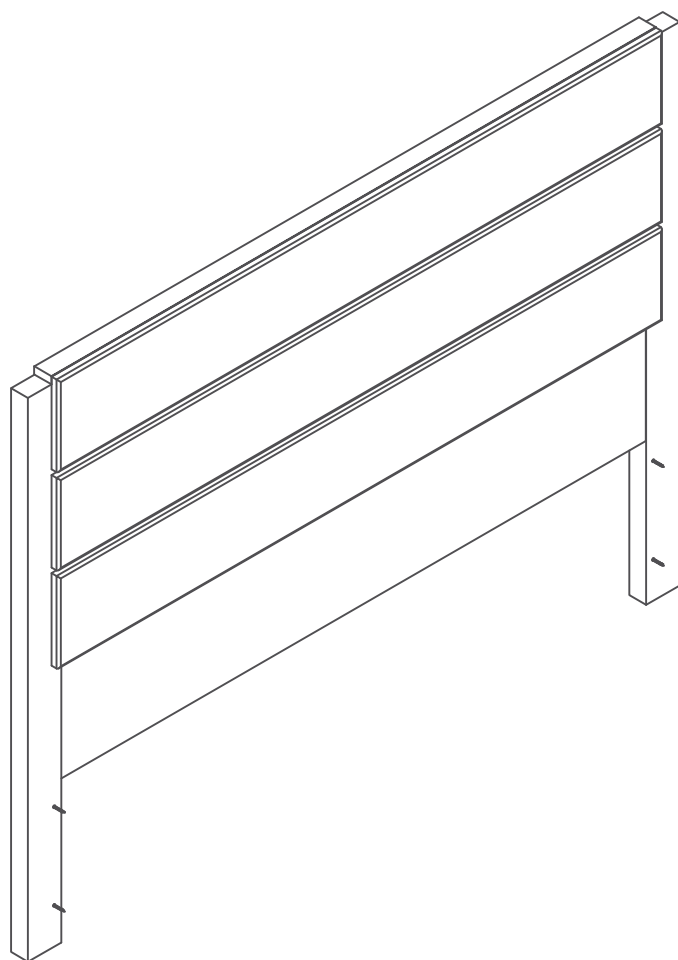

Ready to assemble, ready to be !

Prêt à être assemblé, prêt à être !

Listo para ensamblar, listo para ser !

# 5-YEAR LIMITED WARRANTY

## GARANTIE LIMITÉE DE 5 ANS / GARANTIA LIMITADA DE 5 AÑOS



Our furniture is like family to us. And we never turn our back on family.

Our commitment to our furniture -- and to you -- doesn't end the minute you've purchased the piece. We offer a 5-year warranty on all of our manufactured furniture pieces.

1. We provides the original buyer with a warranty covering "defects" on furniture parts and workmanship for a period of 5 years from the date of purchase.

2. The word "defect" as used in this warranty is defined as any imperfection that may impair the intended use of the product.

3. This warranty is strictly limited to the repair or replacement of defective component parts, and excludes all other direct or indirect charges and expenses up to the limit permitted by law in your state/province.

4. In the case of a discontinued part or product, We promises to reimburse the value of that part or product.

5. If a replacement part is unavailable, liability to the buyer will not exceed the production cost of the part in question.

6. This warranty only applies under conditions of normal domestic use. It does not cover defects

resulting from commercial use, intentional damage, negligence, abuse, product modification, accidents, exposure to the elements, or maintenance that does not comply with the guidelines in this guide.

7. To honor this warranty, reserves the right to verify the grounds of any request and to ask for the original buyer's proof of purchase.

8. This warranty is only valid on purchases made at authorized us.

9. This warranty defines the limits and entitles the original buyer to specific rights. Any warranty defined by law in your state/province is limited to a period of 5 years. If the law in your state/province prohibits this restriction, then it does not apply.

10. We will not reimburse defective furniture, but will replace it with an item of equivalent value.

Nos meubles font partie de la famille. Et la famille, c'est pour la vie. Notre engagement envers nos produits et envers vous ne prend pas fin au moment de l'achat. Nous offrons une garantie de 5 ans sur tous les produits que nous fabriquons.

1. Meubles garanti à l'acheteur original, pour une période de 5 ans à partir de la date d'achat, toutes les composantes des meubles contre les « défauts » de matériaux et de main-d'oeuvre.

2. Le mot « défaut » utilisé dans cette garantie signifie une imperfection pouvant altérer l'utilité pour laquelle le produit est destiné.

3. Cette garantie se limite strictement à la réparation ou au remplacement des pièces composantes défectueuses. Cette garantie exclut tous les autres frais et dépenses directs ou indirects et ce, jusqu'à la limite permise par la législation en vigueur dans votre province/état.

4. Dans le cas d'une réclamation concernant un produit ou une pièce discontinuée, s'engage à rembourser la valeur du produit ou de la pièce en question.

5. À défaut de pouvoir fournir la pièce de remplacement, la responsabilité de ne peut excéder la valeur équivalente au coût de production de la pièce en litige.

6. Cette garantie s'applique sous des conditions d'usage domestique normal et ne couvre pas les défauts pouvant résulter

d'un usage commercial, de dommages intentionnels, de la négligence, de l'usage abusif, de modifications personnelles, d'un accident, de l'exposition aux éléments ou d'un entretien ne respectant pas les conseils décrits dans ce guide.

7. Comme condition pour fournir une pièce de remplacement, Meubles réserve le droit de vérifier le fondement de la requête, de même que d'exiger la preuve d'achat de l'acheteur original.

8. Cette garantie n'est valide que si et seulement si l'achat a été effectué chez un marchand autorisé par Meubles au Canada, aux États-Unis, au Mexique.

9. Cette garantie définit les limites de la responsabilité de donner à l'acheteur original des droits spécifiques. Toute garantie législative prévalant dans votre lieu de résidence est limitée à une période de 5 ans. Si cette restriction n'est pas permise par la législation de votre lieu de résidence, elle ne s'applique pas.

10. ne remboursera pas un meuble défectueux, mais le remplacera par un autre de valeur équivalente.

Nuestros muebles son como una familia para nosotros y la familia, es para toda la vida.

Nuestro compromiso con nuestros muebles y con usted no termina al momento de la compra. Ofrecemos una garantía de 5 años en todos nuestros productos fabricados.

1. Al comprador original, por un periodo de 5 años a partir de la fecha de compra, todas las piezas que componen el mueble contra los « defectos » de material y mano de obra.

2. La palabra « defecto » utilizada en esta garantía se define como toda imperfección que pueda alterar la utilidad para la cual se destina el producto.

3. Esta garantía se limita estrictamente a la reparación o reemplazo de las piezas que tengan componentes defectuosos. Esta garantía no incluye cualquier gasto directo

o indirecto hasta el límite permitido por la legislación vigente en su lugar de residencia.

4. En el caso de una reclamación referente a un producto o pieza discontinuada, compromete a reembolsar el valor del producto o pieza en cuestión.

5. A falta de poder suministrar la pieza de repuesto, la responsabilidad de no puede exceder el valor equivalente al costo de producción de la pieza en litigio.

6. Esta garantía se aplica bajo las condiciones de uso doméstico normal y no cubre los defectos que puedan resultar de un

uso comercial, daños intencionales, negligencia, uso abusivo, modificaciones personales, un accidente, exposición a los elementos y mantenimiento sin respetar los consejos que se describen en este instrucción.

7. Como condición para suministrar una pieza de repuesto, reservan el derecho de verificar el fundamento de la solicitud, así como de exigir la prueba de compra del comprador original.

8. Esta garantía sólo será válida si la compra se efectuó en una autorizado por Canadá, tienda estados Unidos, México.

9. Esta garantía define los límites de la responsabilidad de otorga el comprador original los derechos específicos. Cualquier garantía legislativa que prevalece en su lugar de residencia está limitada a un periodo de 5 años. Si esta restricción no está permitida por la legislación de su lugar de residencia, ésta no se aplica.

10. hará ningún reembolso por muebles defectuosos, pero le enviará uno de valor equivalente.

# 1

## Let's get handy!

Mettons-nous au travail ! / ¡ Vamos a ponernos prácticos !

01

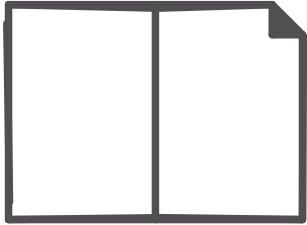

02

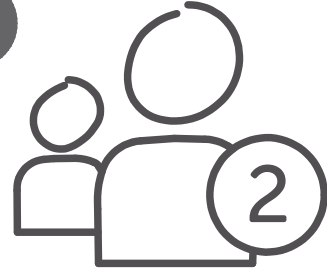

03

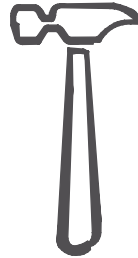
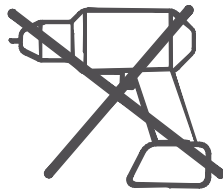

04

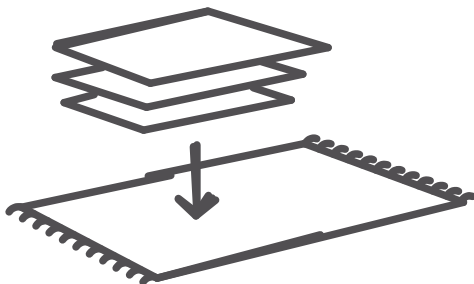

05

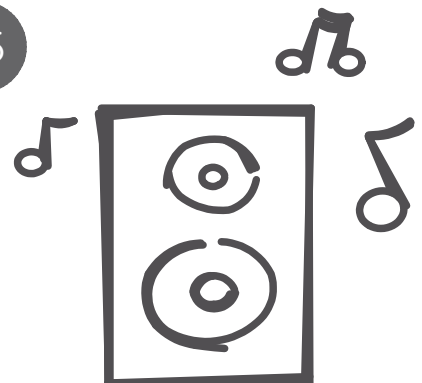

2

## Collect the pieces together

Rassembler les morceaux ensemble

Poner las piezas juntas

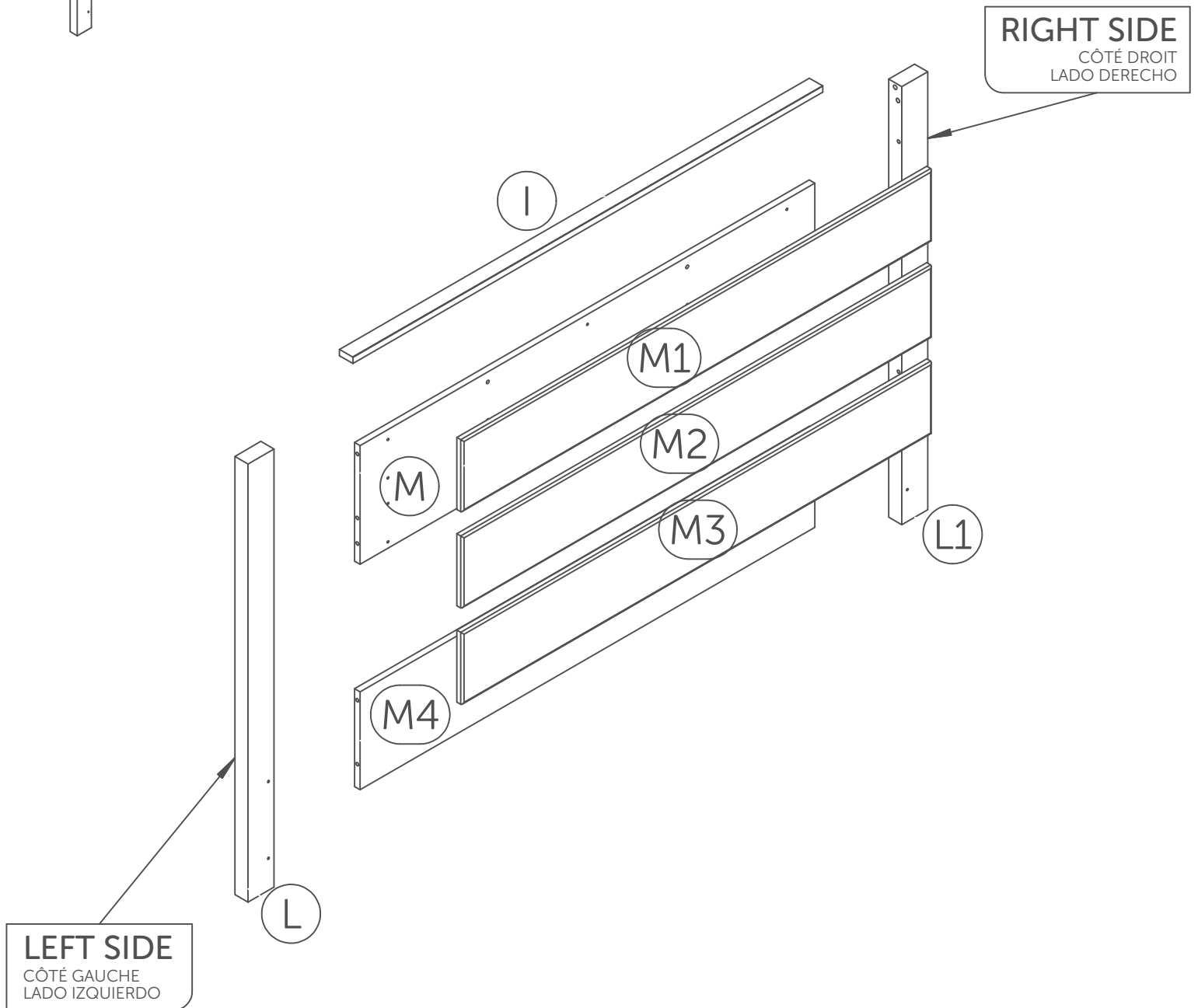
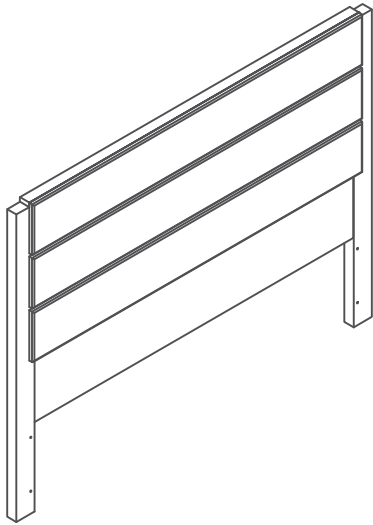

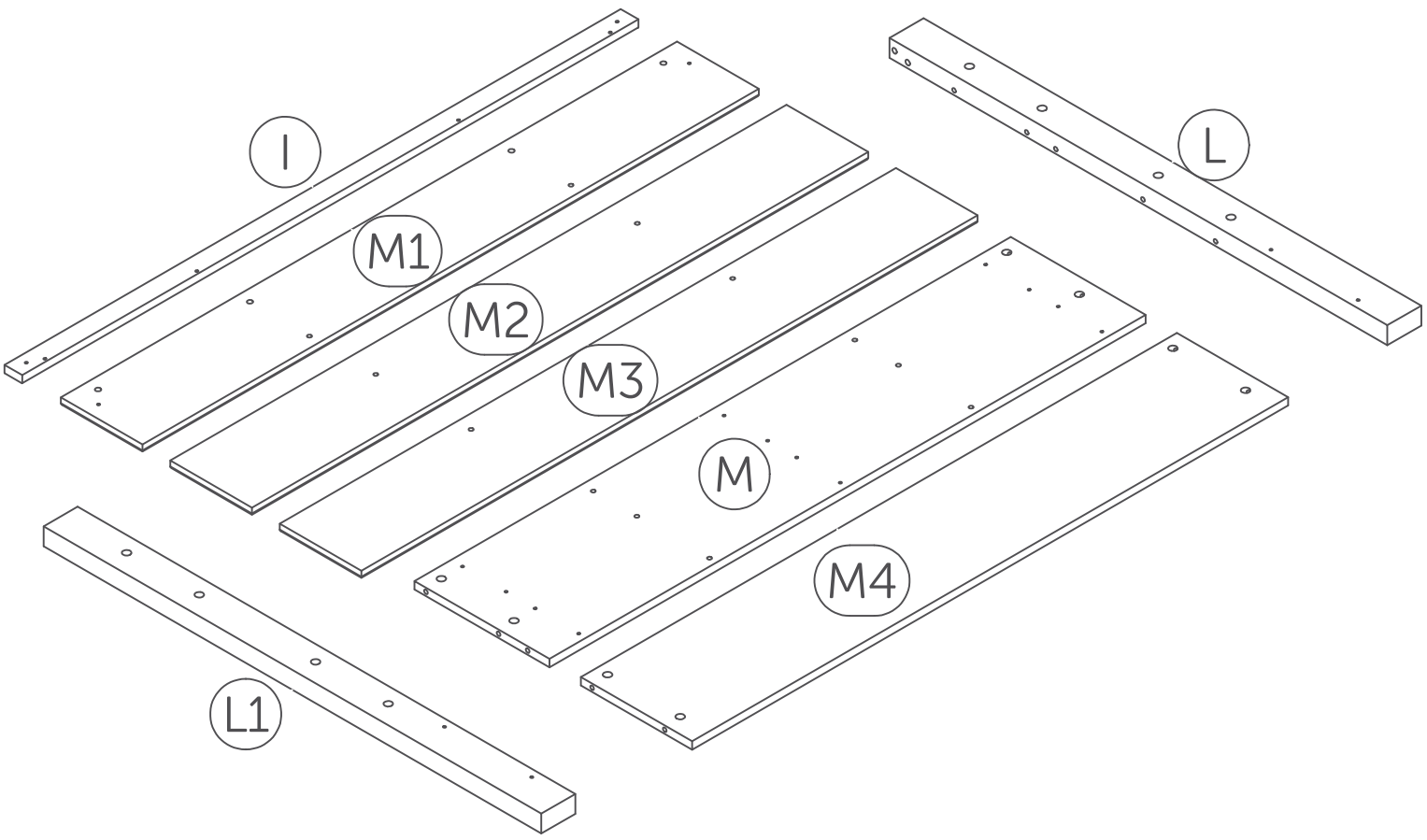
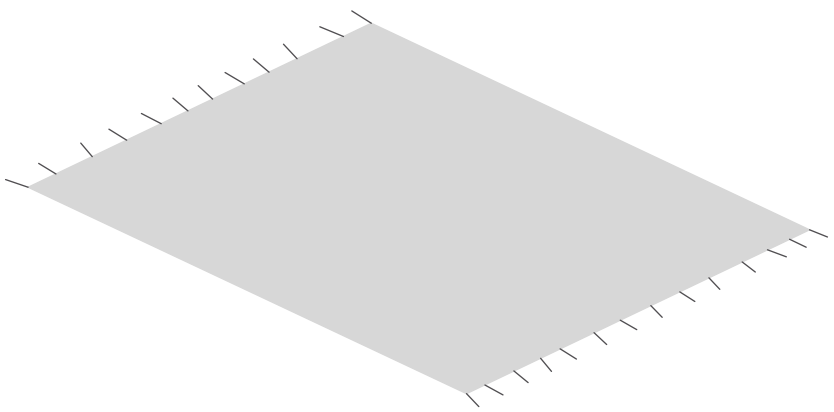
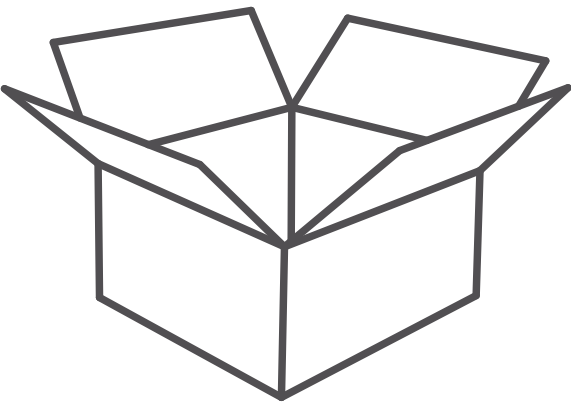

# 3

## Collect the hardware

Rassembler la quincaillerie / Reunir los artículos de ferretería

1 : 1



Full scale  
Taille réelle  
De tamaño real

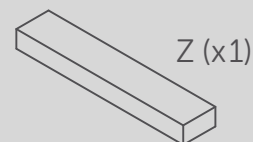
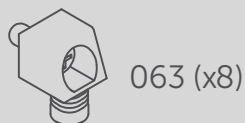
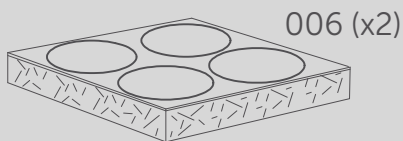
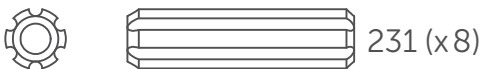
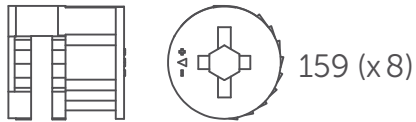
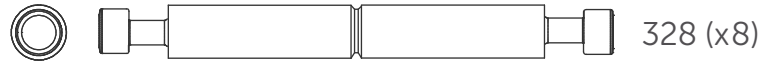
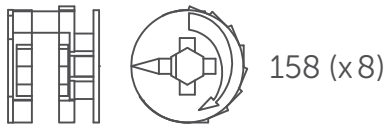
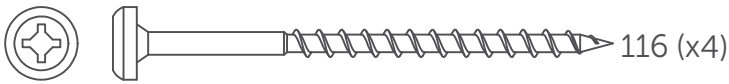
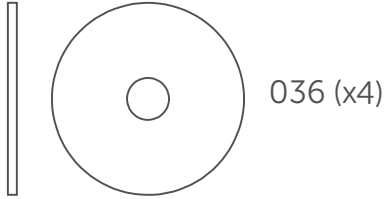

\*Hardware package may have spare parts.  
\*Le sac de quincaillerie peut contenir des pièces de remplacement.  
\*La bolsa de herraje puede contener piezas adicionales de repuesto.

# 4

## Things to remember for assembly

À retenir lors de l'assemblage / A recordar durante el ensamblaje

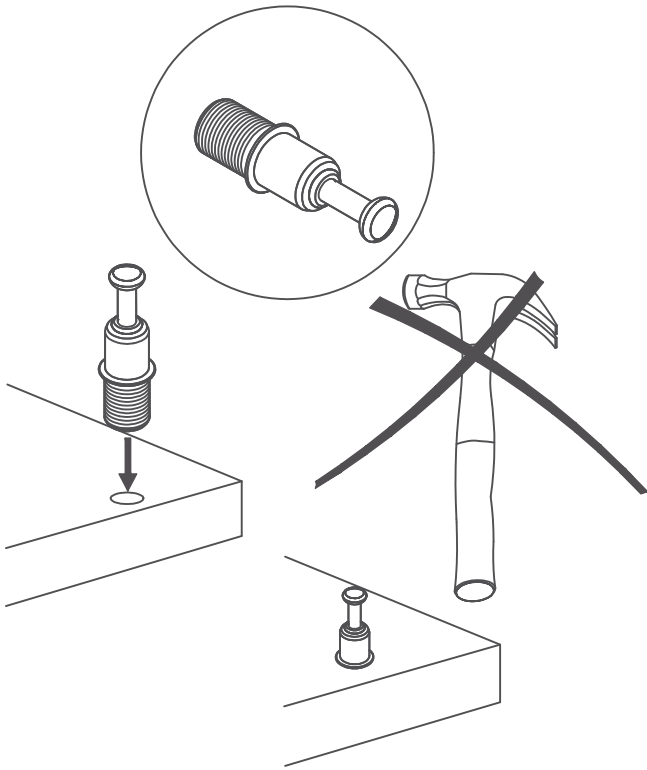

To remove: Twist and pull  
Pour enlever: Tourner et tirer

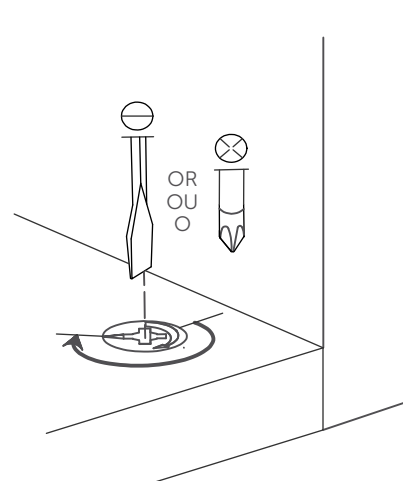
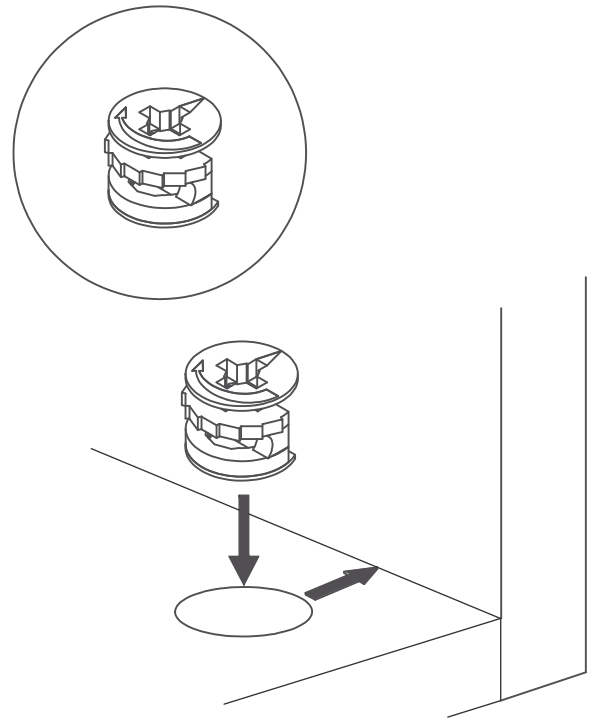
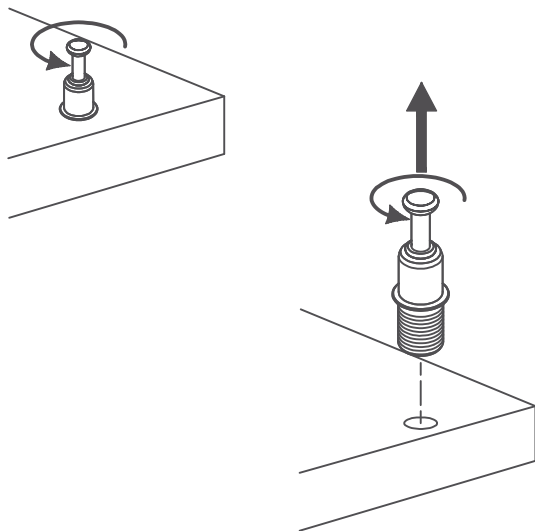

Screw pass the half way point  
Visser plus qu'un demi tour

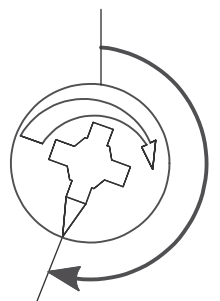

# 5

## 5.1

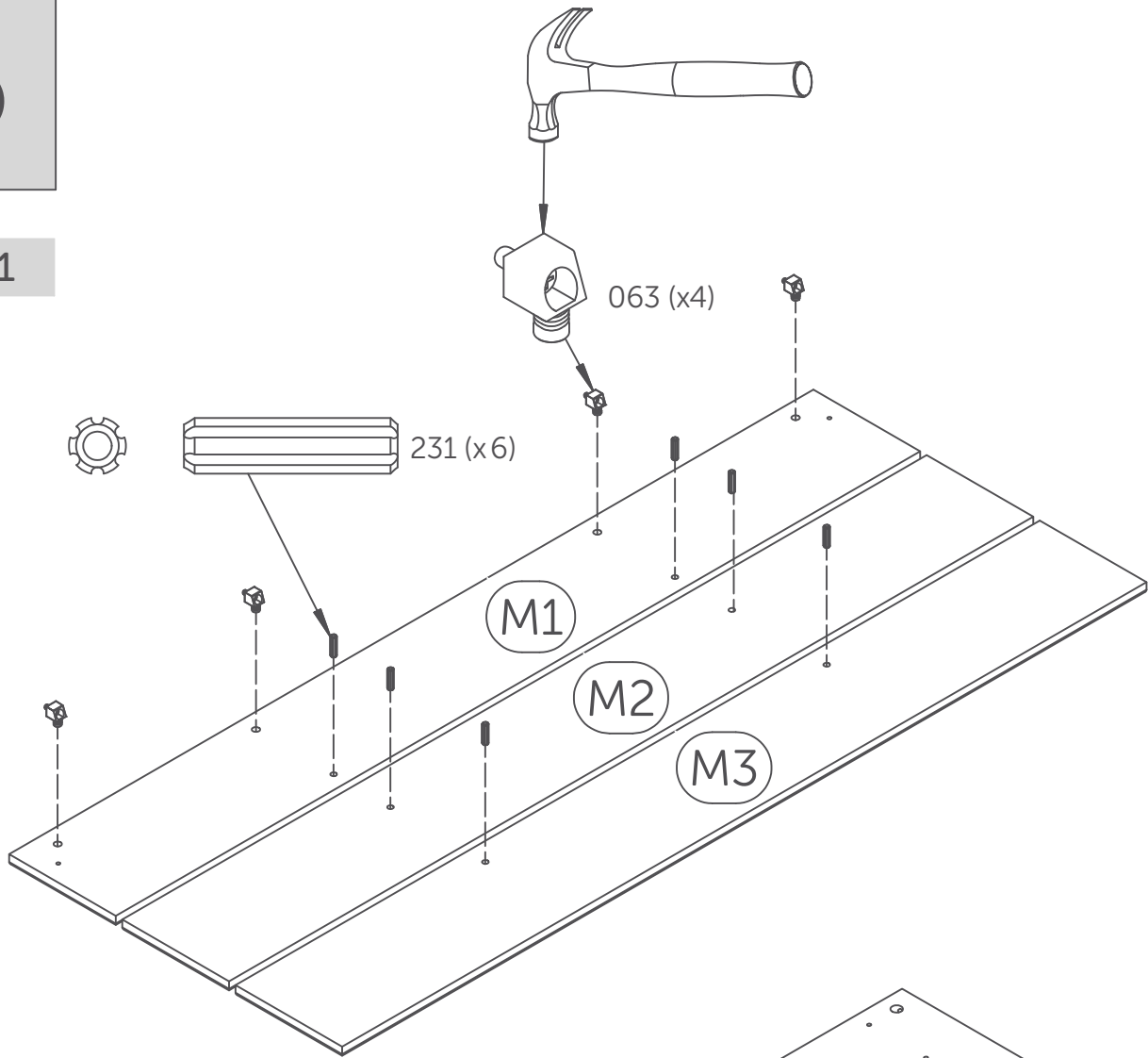

## 5.2

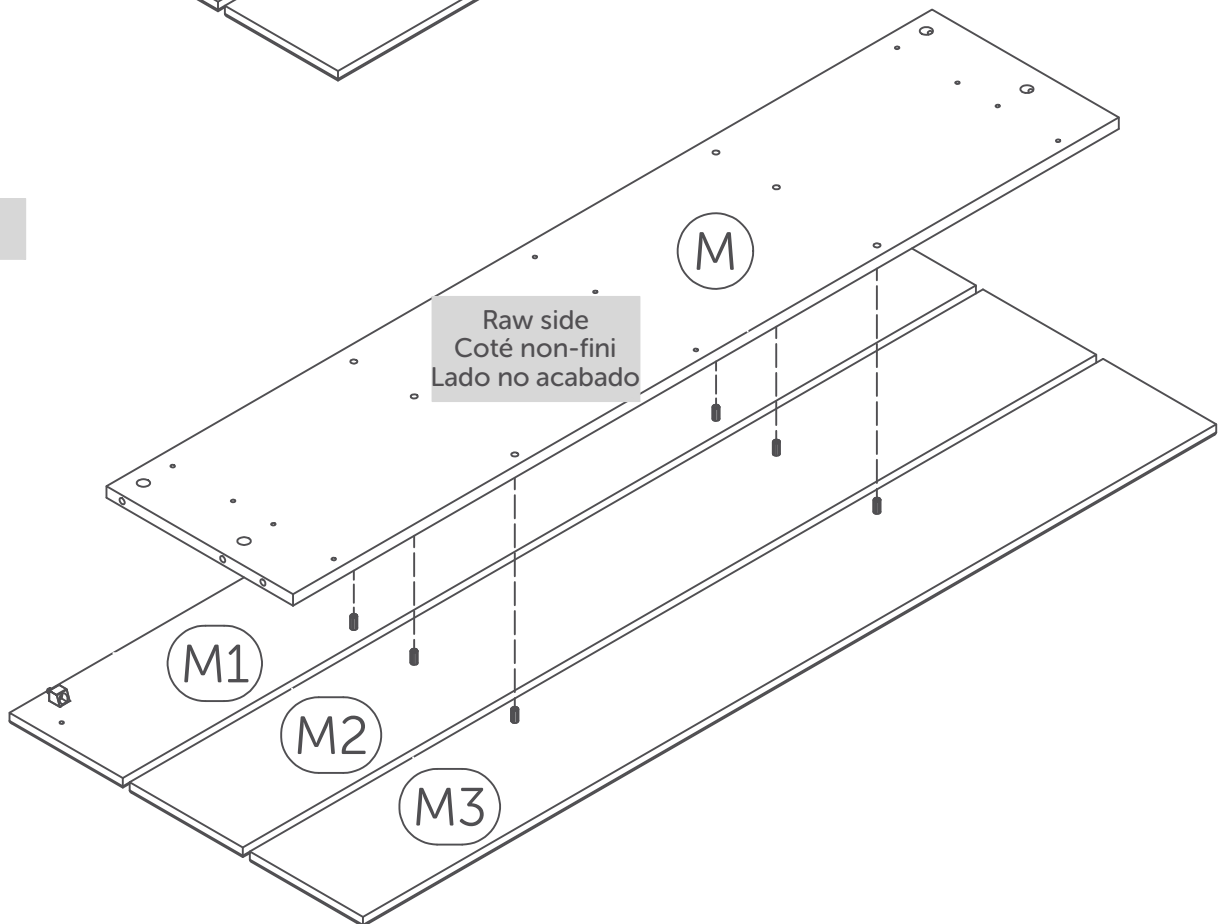

# 6

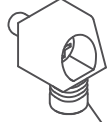
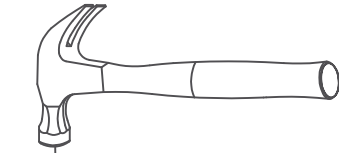

063 (x2)

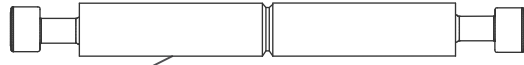

328 (x8)

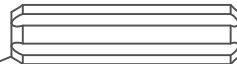

231 (x2)

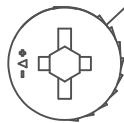
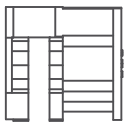
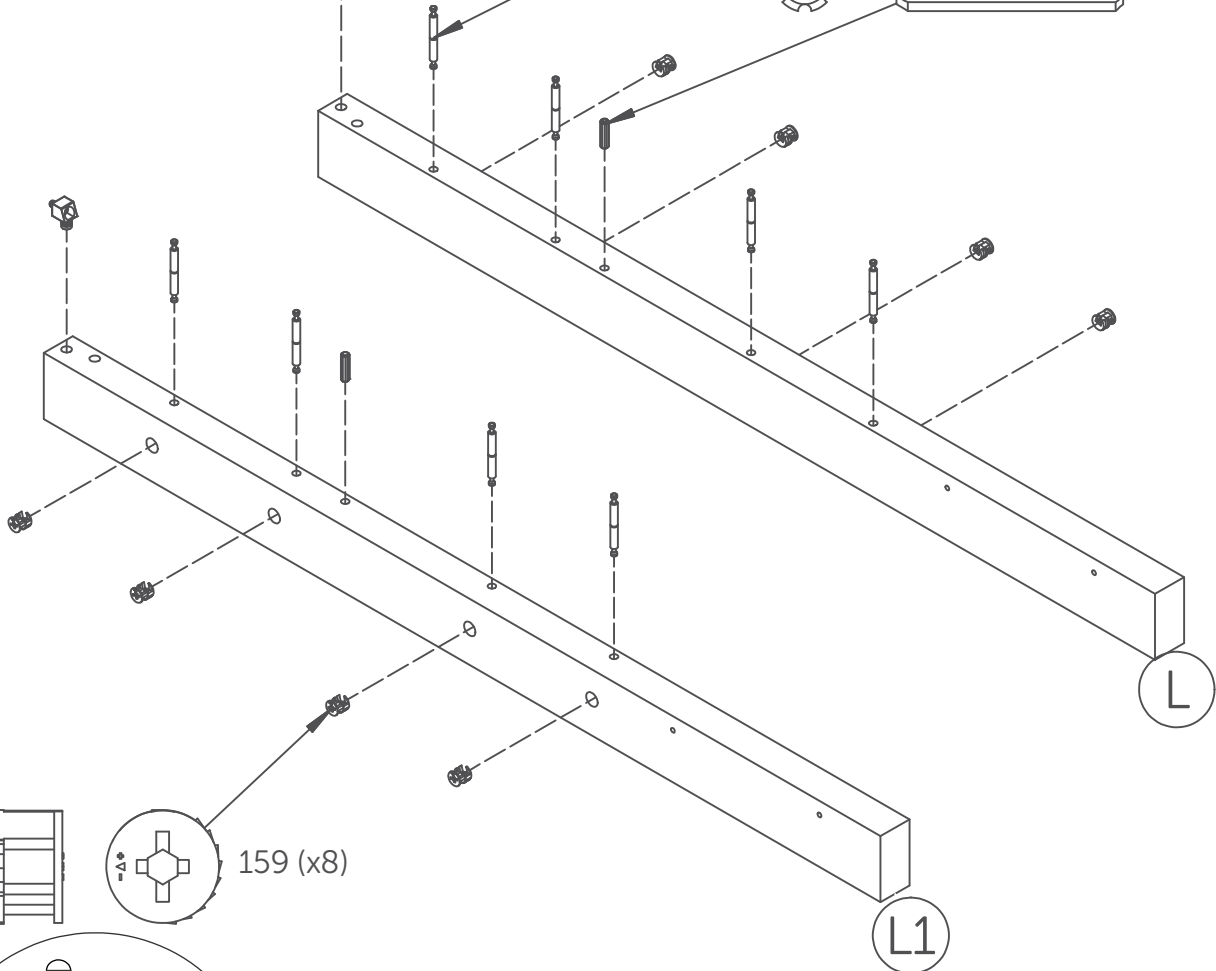

159 (x8)

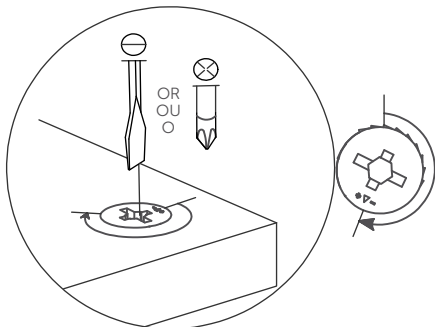

Screw past the halfway point  
Visser plus qu'un demi tour

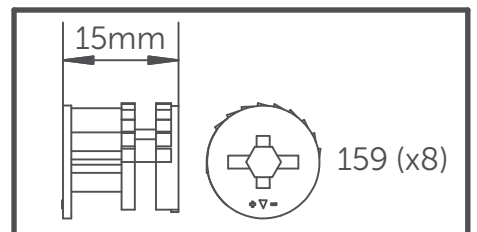

159 (x8)

# 7

## 7.1

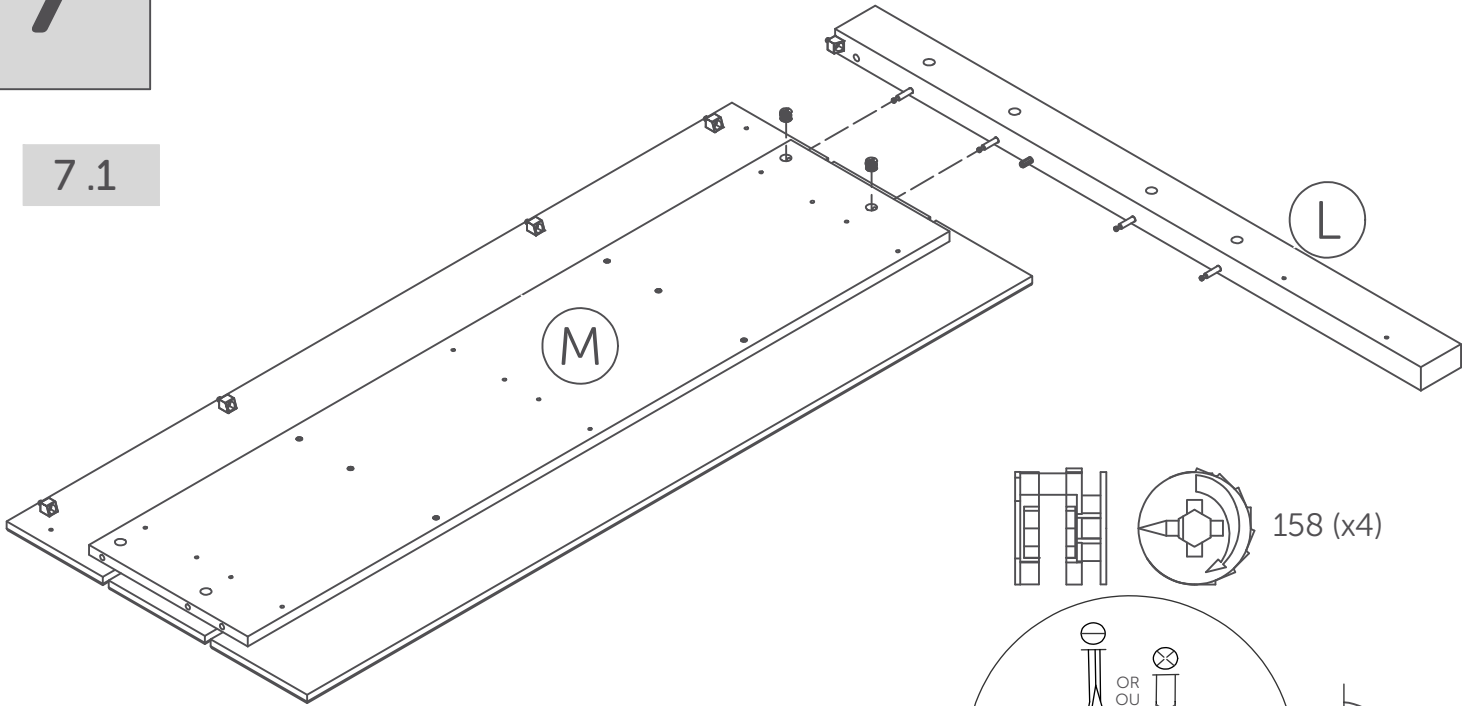

## 7.2

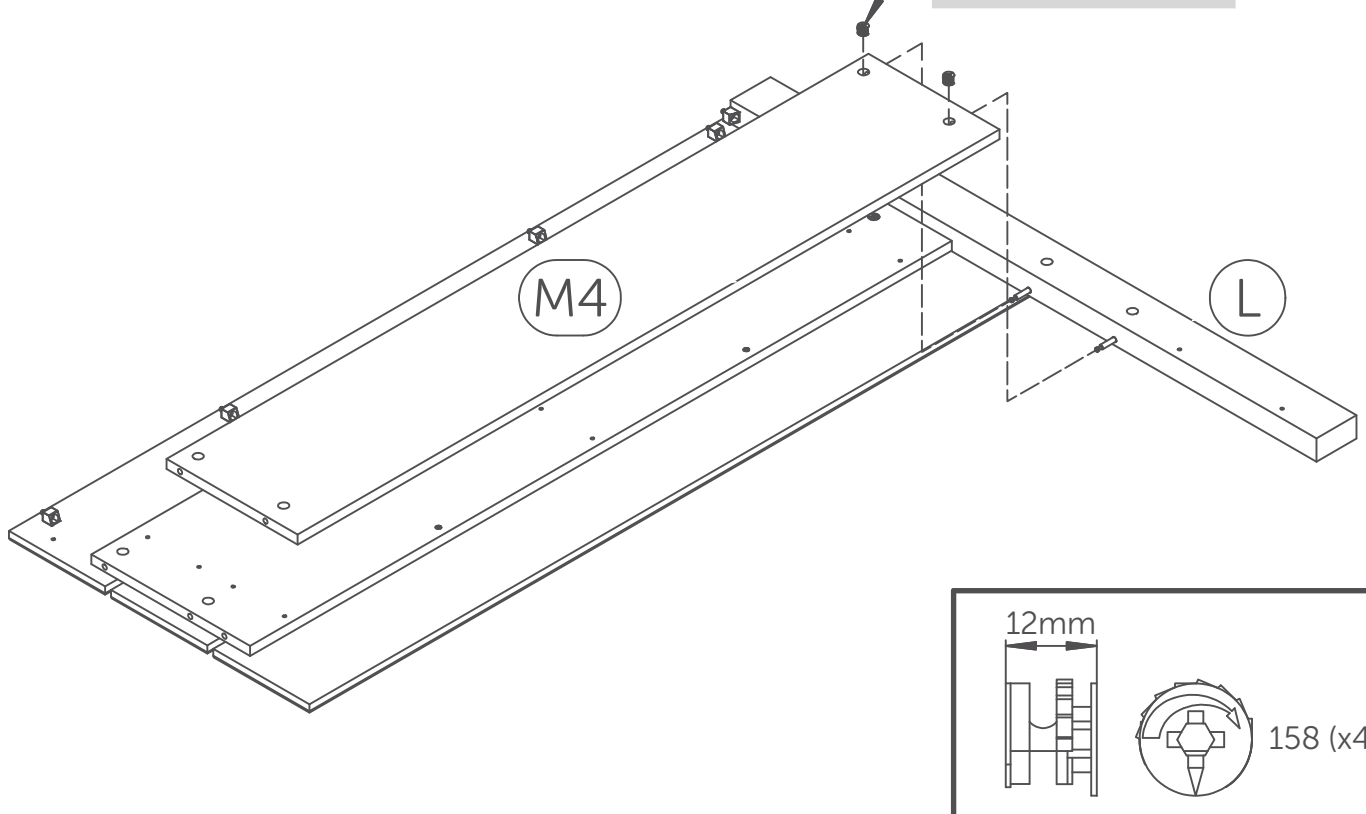

8

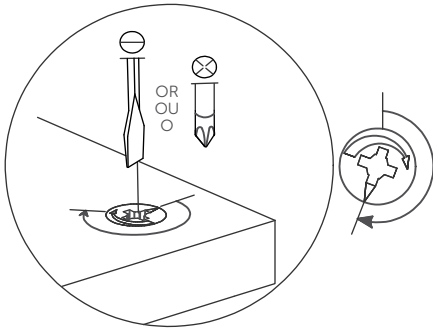
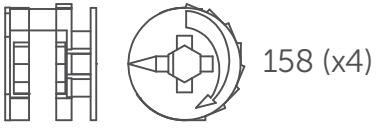
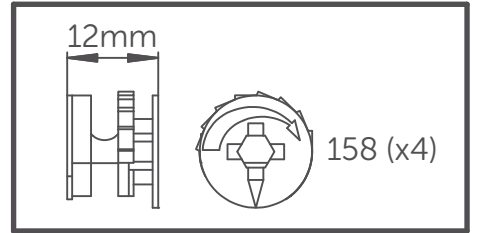

Screw past the halfway point  
Visser plus qu'un demi tour

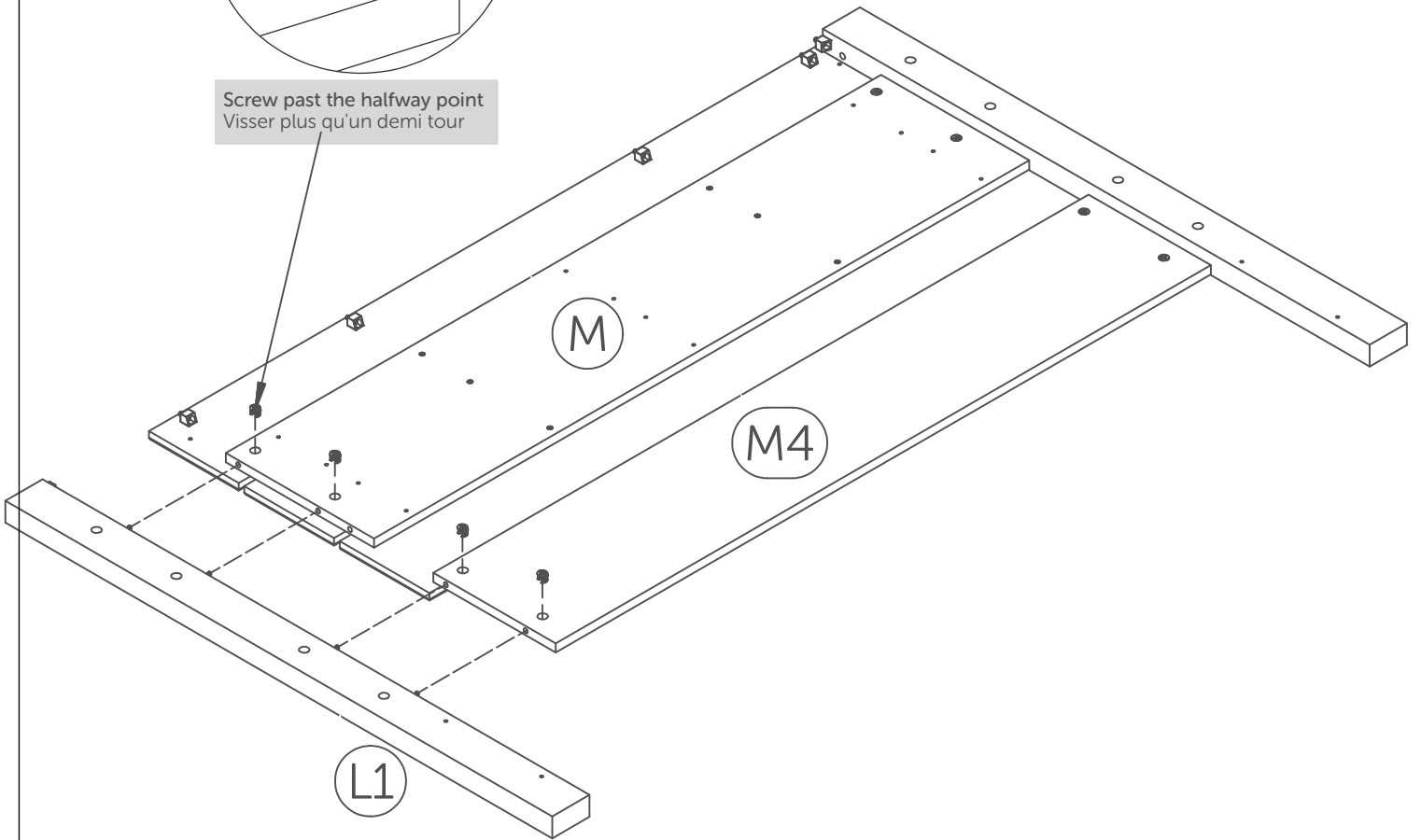

9

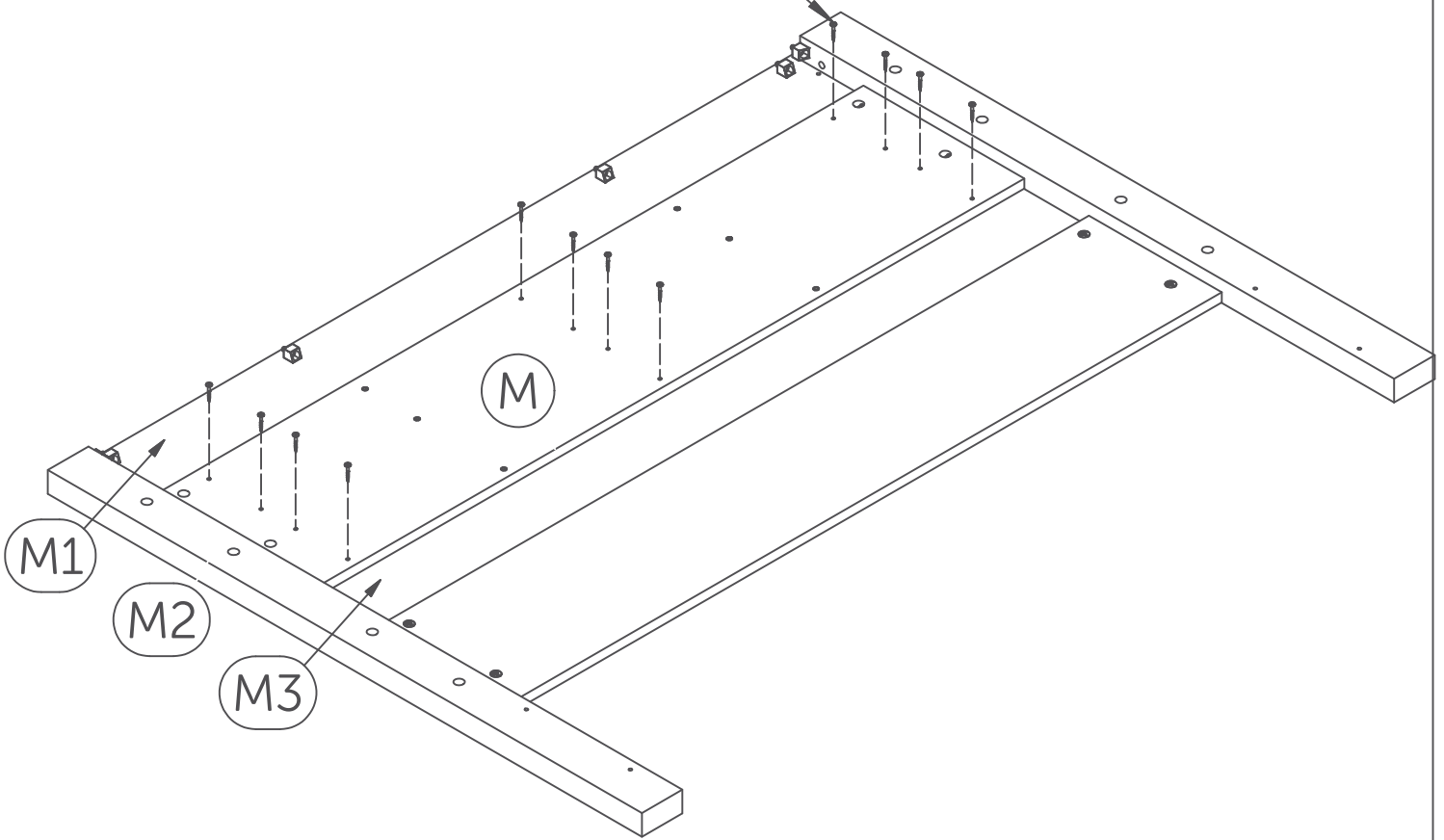
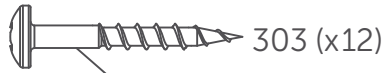
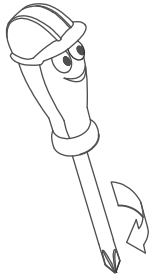

10

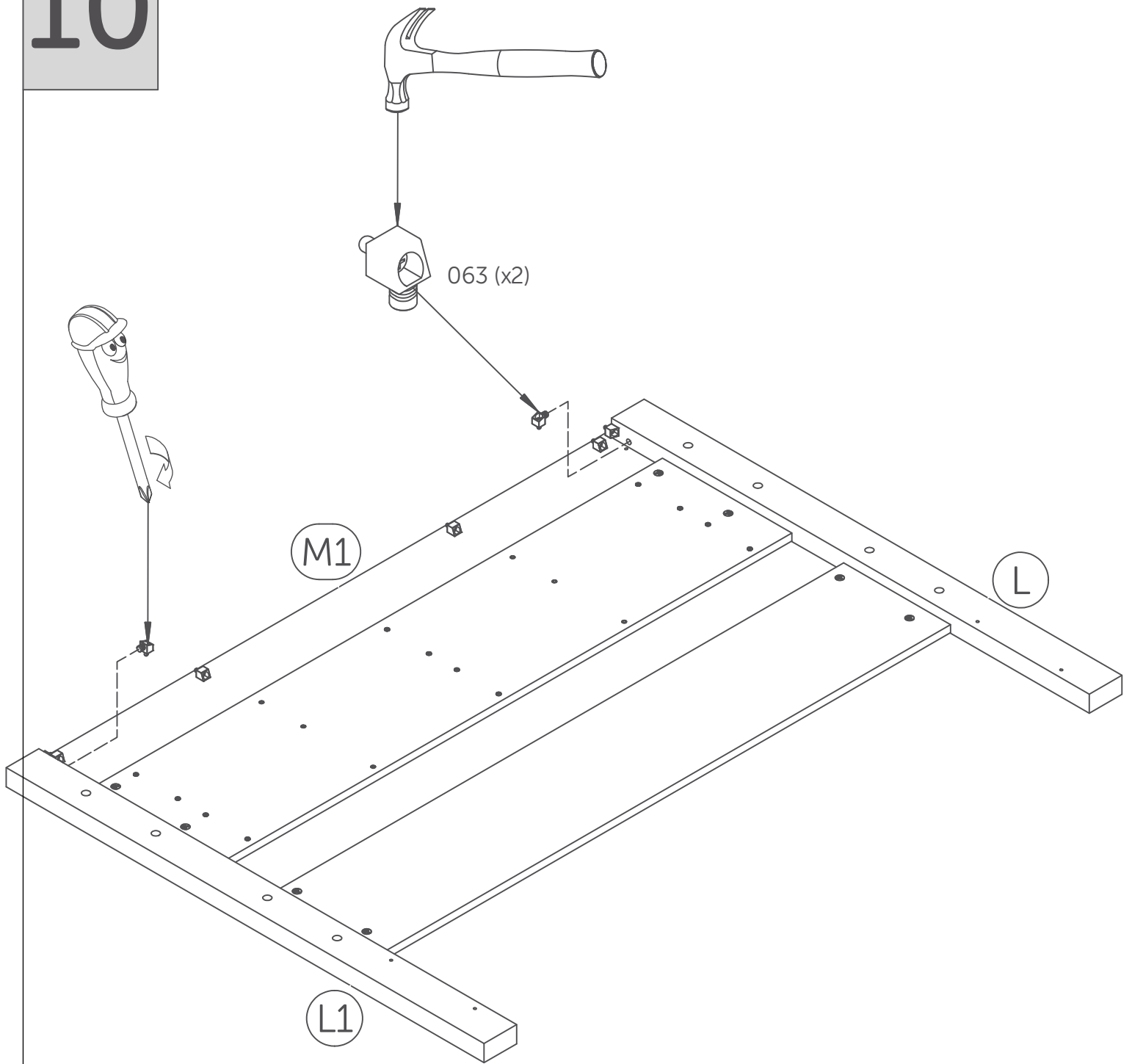

11

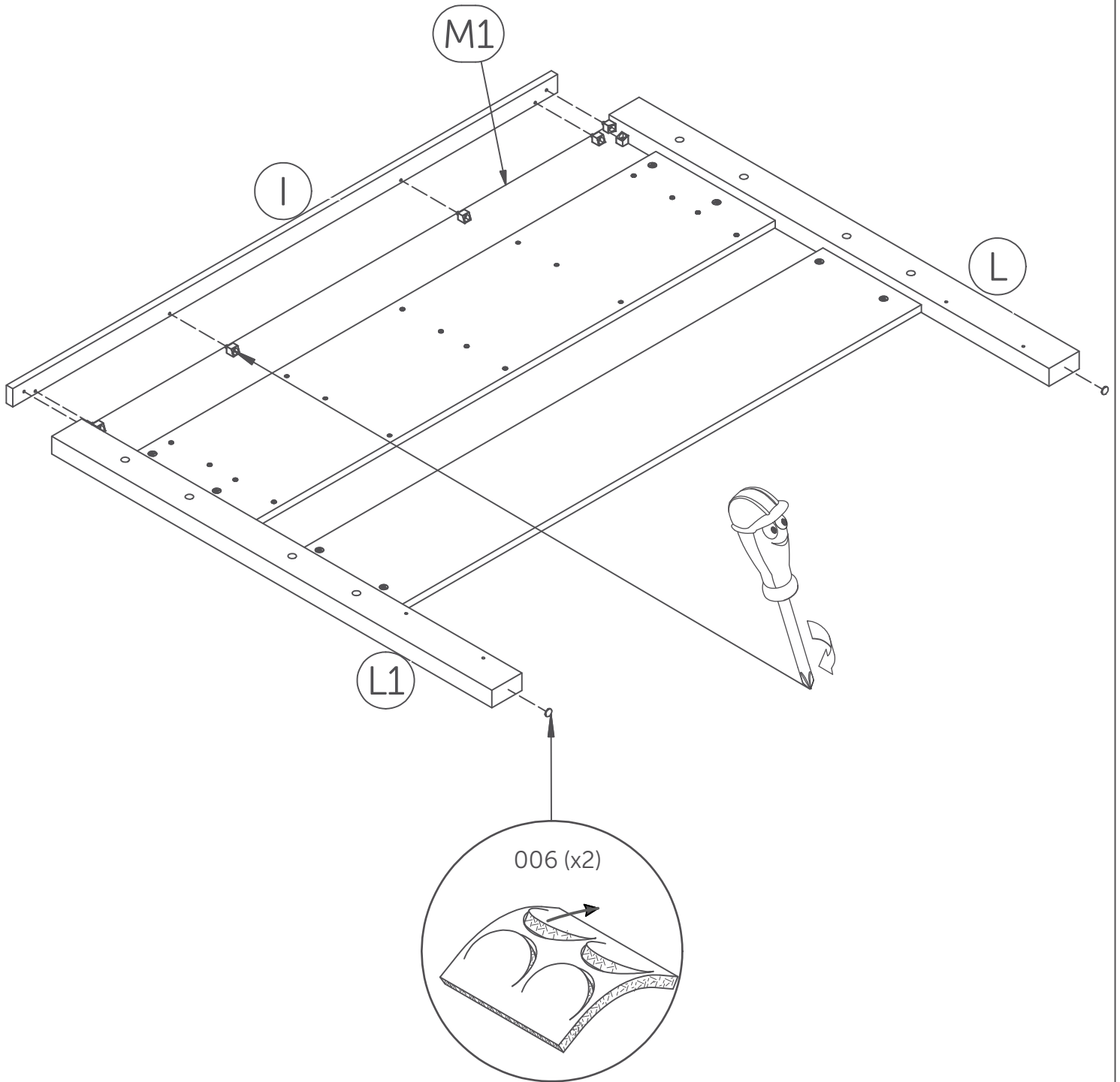

Option/Opción A

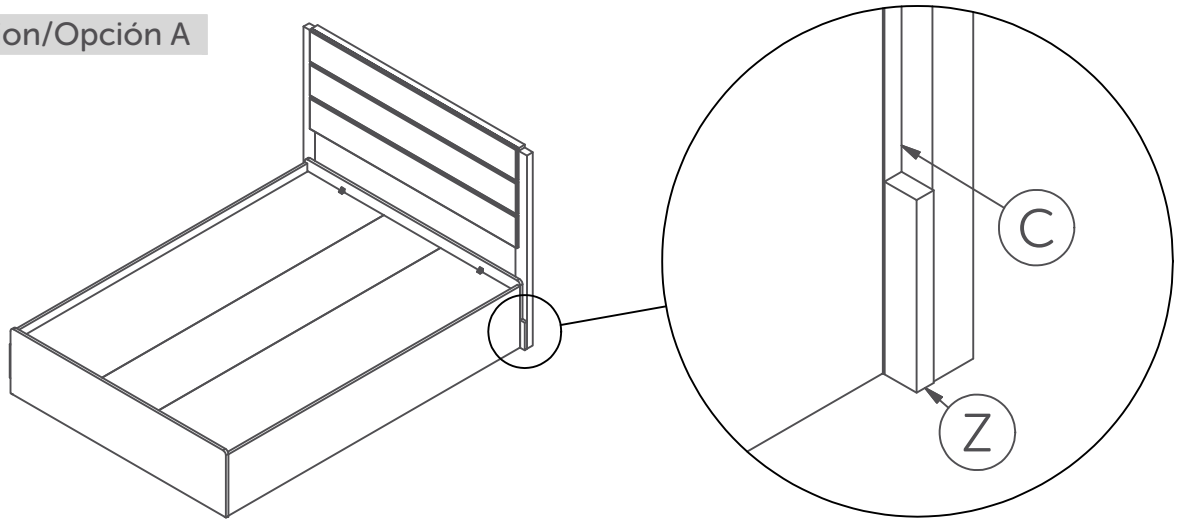

The headboard is 2 ½" wider than the bed. Center the headboard with a 1 ¼" overhang past panel C on both sides using the Z bloc spacer.

La tête de lit est 2 ½" plus large que le lit. Centrer la tête de lit avec un dépassement de 1 ¼" au-delà de la pièce C en utilisant le bloc Z fourni.

La cabecera es 2 ½" más ancha que la cama. Centre la cabecera a una distancia de 1 ¼" de la pieza C utilizando el bloque en Z proporcionado.

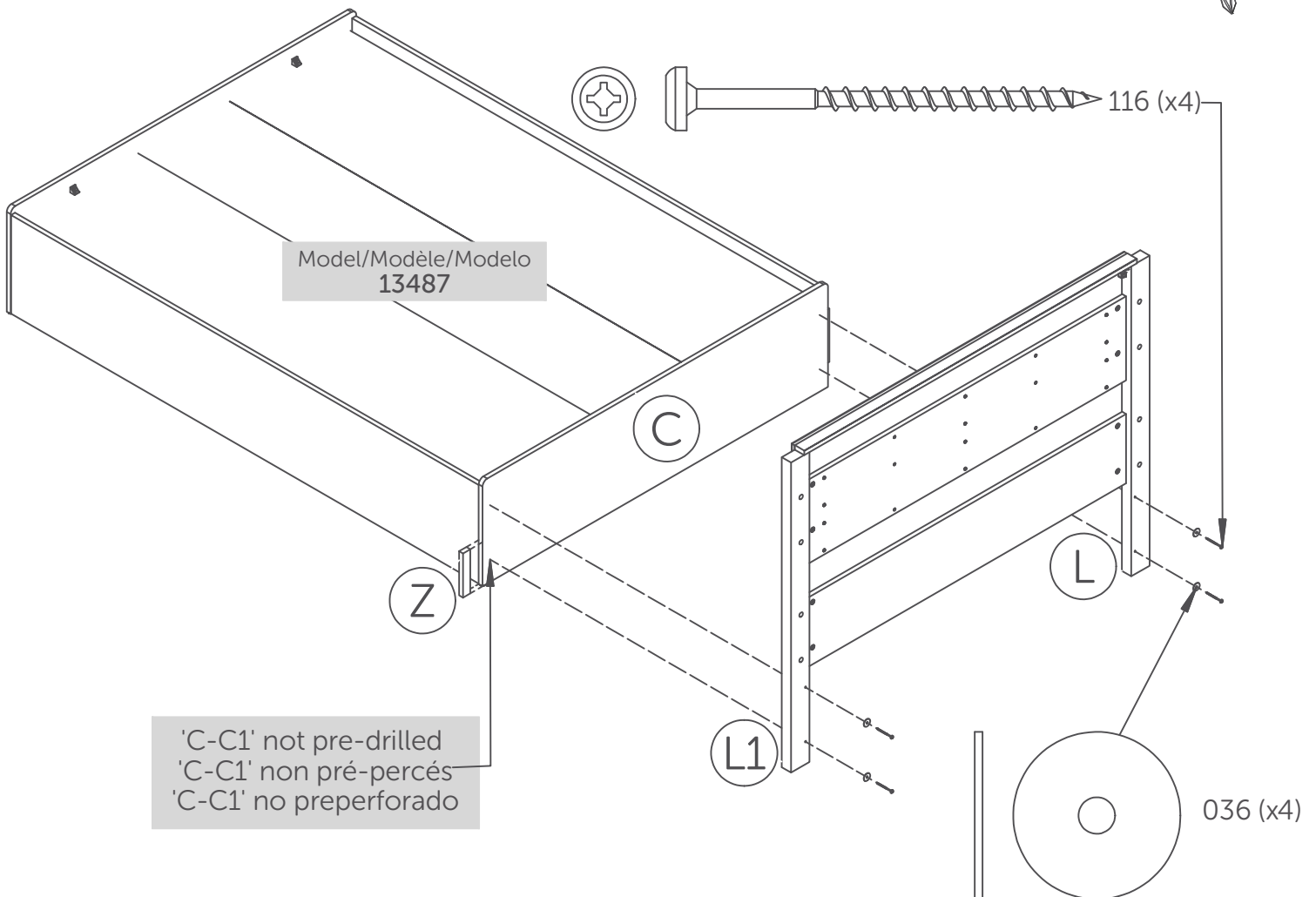
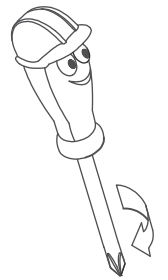

# 13

## Option/Opción B

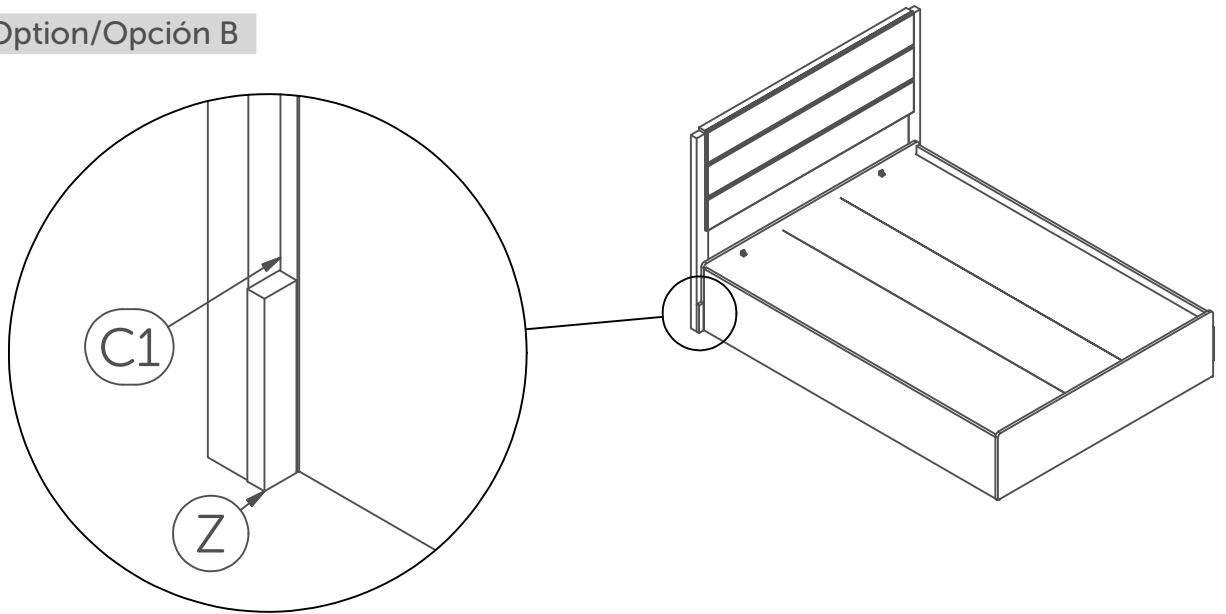

The headboard is 2 ½" wider than the bed. Center the headboard with a 1 ¼" overhang past panel C1 on both sides using the Z bloc spacer.

La tête de lit est 2 ½ " plus large que le lit. Centrer la tête de lit avec un dépassement de 1 ¼" au-delà de la pièce C1 en utilisant le bloc Z fourni.

La cabecera es 2½" más ancha que la cama. Centre la cabecera a una distancia de 1 ¼ " de la pieza C1 utilizando el bloque en Z proporcionado.

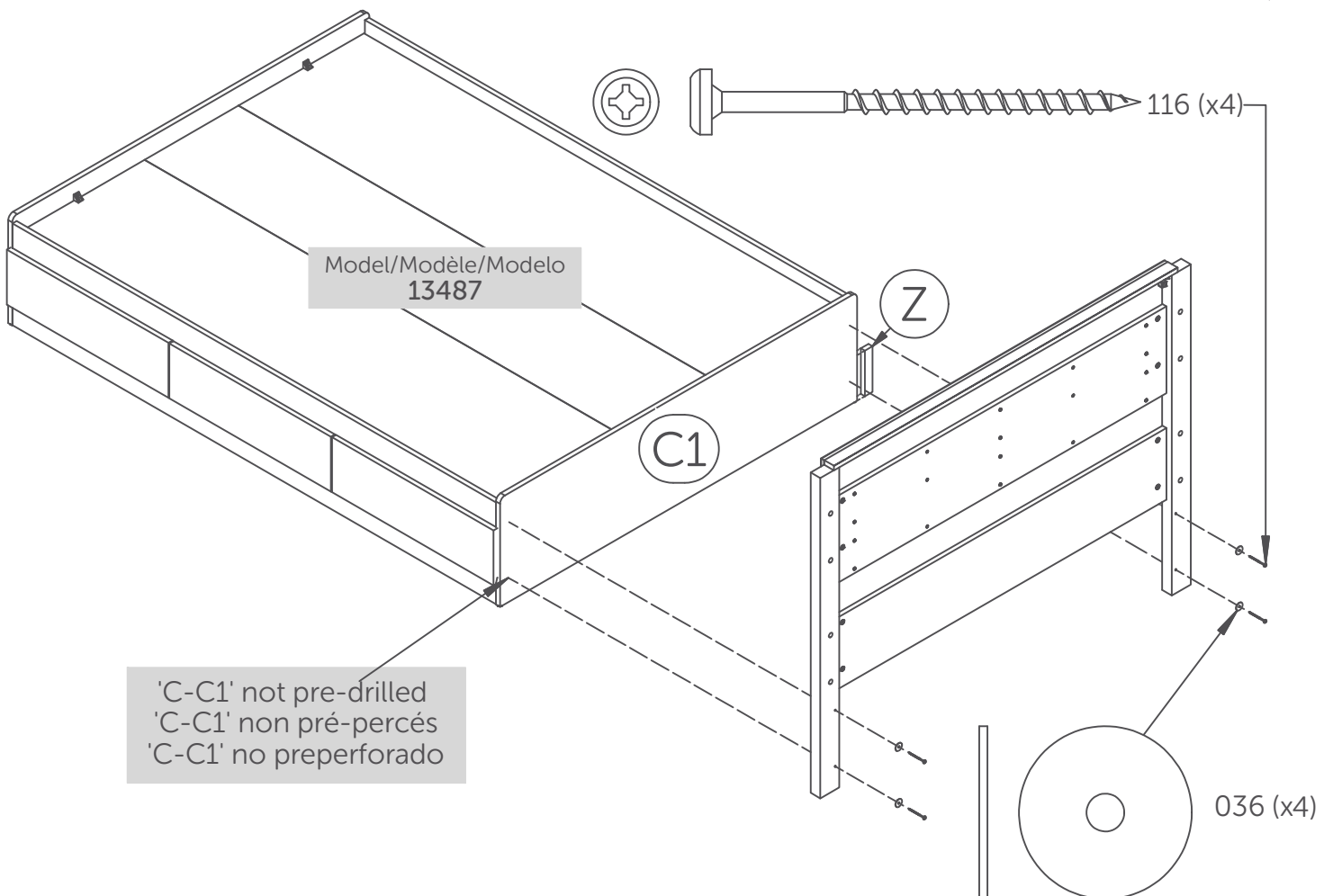
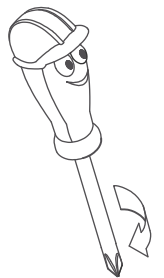

# MAINTENANCE TIPS

CONSEILS D'ENTRETIEN / CONSEJOS DE MANTENIMIENTO



Never let liquids or damp cloths sit on this furniture.

Ne jamais laisser de liquide ou linge humide sur le meuble.

Nunca deje un líquido o un trapo húmedo sobre el mueble.



Never use chemical cleaning products. They can damage the finish. For cleaning, use only a slightly damp cloth and wipe dry.

Ne jamais utiliser de produits nettoyants à base de produits chimiques, cela va endommager le fini. Utiliser seulement un linge légèrement humide.

Nunca utilice limpiadores a base de químicos, estos dañaran le acabado. Use sólo un paño húmedo.

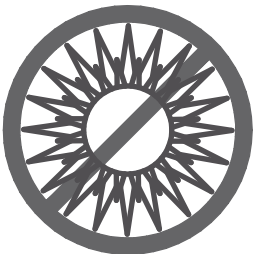

To avoid dulling of the finish, do not place furniture in direct sunlight.

Ne pas placer le meuble directement au soleil pour prévenir le ternissement.

No exponga el mueble directamente al sol para prevenir empañamiento.

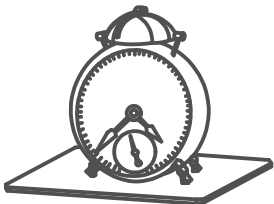

Do not put plastic or rubber rings under appliances. Use cloth or felt protectors.

Évitez de déposer des appareils avec des rondelles de plastique ou de caoutchouc. Utilisez un protecteur en tissu ou en feutre.

Evite apoyar aparatos con redondeles de plástico o de goma. Utilizar un protector de tela o de fieltro.



To clean, use a soft or slightly damp cloth, then wipe with a clean, dry cloth.

Pour nettoyer, utilisez un linge doux ou légèrement humecté. Essuyez par la suite avec un linge propre et sec.

Para limpiar, utilice un trapo suave o ligeramente humedecido. Seque luego con un trapo limpio y seco.