





ASSEMBLY INSTRUCTIONS

1270023

HARDWARE

<p>Ax8</p>  <p>M6 x 40 mm</p>	<p>Bx8</p>  <p>Ø17 x 1.5 mm</p>	<p>Cx8</p>  <p>Ø13 x 1.5 mm</p>	<p>Dx1</p>  <p>4 mm</p>
--	--	---	--

PARTS

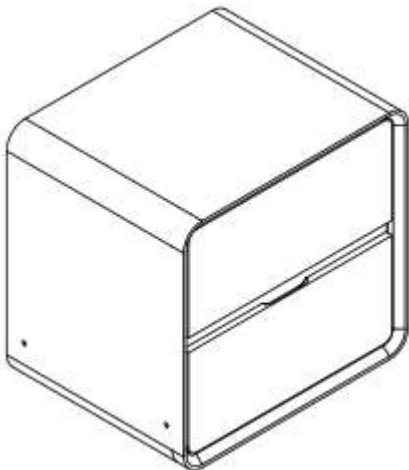
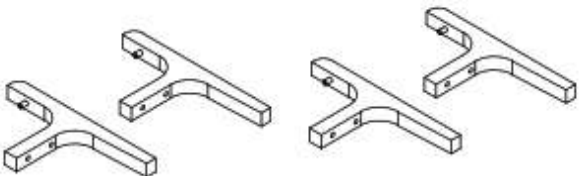
<p>1x1</p> 	<p>2x4</p> 
--	---

(1)

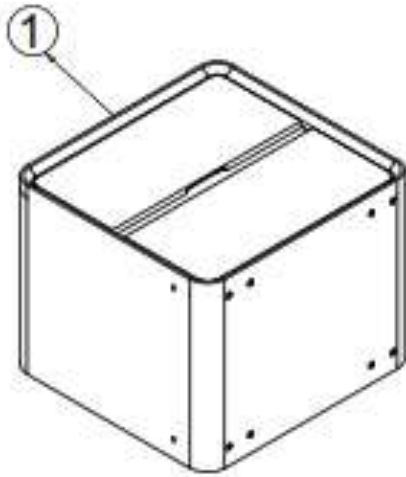

- Place Nightstand (1) in the position as shown in the picture.

(2)

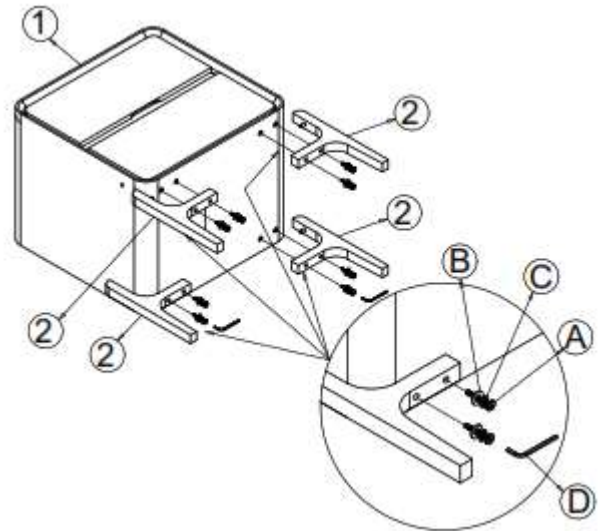

- Place the Leg (2) in the hole provided at the bottom of the Nightstand (1), then insert the Bolt (A) with the Flat Washer (B) and Spring Washer (C) then tighten with the Allen key (D).
- Do the same with the other legs.
- Note: For the side parts, use wooden dowels that have been installed on the legs (2).

(3)

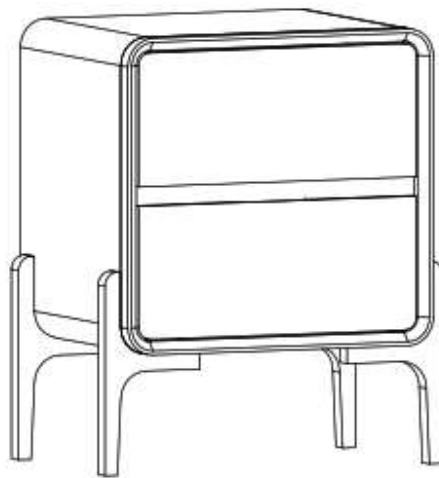

- Completed