

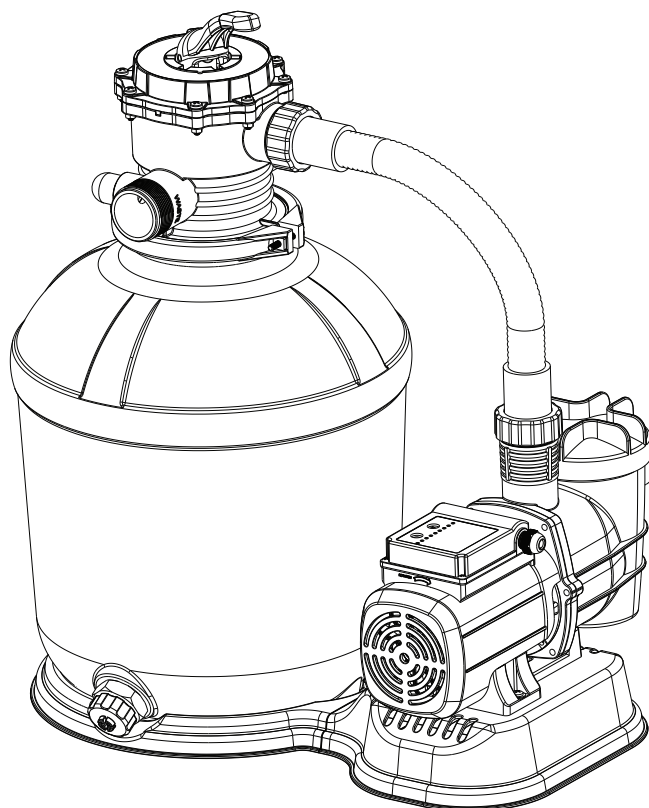

POOL PUMP AND SAND FILTER SYSTEM

0.75 HP 110 V 16 INCH 7-WAY ABOVE-GROUND

ITEM: 75131



INSTALLATION AND USER'S GUIDE

⚠ DANGER

Read all safety warnings and instructions. Failure to follow the warnings and instructions may result in electric shock, fire and/or serious injury. Save all warnings and instructions for future reference.

75131

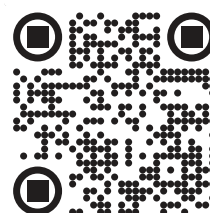

TABLE OF CONTENTS

TABLE OF CONTENTS	0
IMPORTANT SAFETY INSTRUCTIONS	2
<i>Legends and Symbols</i>	2
GENERAL SAFETY.....	4
OVERVIEW (PRODUCT INFORMATION)	6
PACKAGE CONTENTS.....	6
PUMP AND SAND FILTER SYSTEM.....	7
PRODUCT DIMENSIONS.....	8
SPECIFICATIONS.....	9
INSTALLATION	10
PUMP LOCATION.....	10
ELECTRICAL.....	11
INSTALLATION INSTRUCTIONS.....	12
STEP 1: PUMP BASE ASSEMBLY.....	12
STEP 2: SAND FILTER DRAIN INSTALLATION.....	13
STEP 3: MEDIA ASSEMBLY INSTALLATION.....	14
STEP 4: ADDING FILTER MEDIA.....	15
STEP 5: PRESSURE GAUGE INSTALLATION.....	16
STEP 6: FLANGE CLAMP INSTALLATION.....	17
STEP 7: TANK ATTACHMENT.....	18
STEP 8: HOSE ACCESSORIES ATTACHMENT.....	19
STEP 9: HOSE ATTACHMENT.....	20
STEP 10: POWER CONNECTION.....	21
OPERATION	22
PRIOR TO START-UP.....	22
PRIMING THE PUMP.....	23
AFTER PRIMING THE PUMP.....	24
VALVE FUNCTIONS.....	25
BACKWASH (Initial Run).....	25
RINSE (Initial Run).....	26
FILTER (Normal Operation).....	27
RECIRCULATE (Move The Water Around Without Filtering).....	28
WASTE (Bypass Filter Media For Direct Water Exit).....	29
CLOSED (Shut Off The Flow To The Filter and Pool).....	30
WINTER (For Winterizing).....	31
CONTROL PANEL.....	33
TIMER SETUP.....	33
TIMER AND OPERATION MODES.....	33
REGULAR INSPECTION AND MAINTENANCE.....	34
TROUBLESHOOTING	35

TABLE OF CONTENTS

MAINTENANCE	40
Pump Maintenance	40
Water Chemistry	41
REPLACEMENT PARTS	42
Parts Diagram	42
DISCLAIMER	43
Disclaimer	43
Customer Service	43

IMPORTANT SAFETY INSTRUCTIONS





IMPORTANT SAFETY INSTRUCTIONS

This guide provides instructions for installing and using the product. If you have any questions about the product, please contact XtremepowerUS.

This guide contains important information about safely installing and operating this product. After installation, make sure to share this information with the owner/operator or leave it with them for their reference.

Legends and Symbols

When you come across the safety-alert symbol on the product or in this manual, pay attention to the following signal words and remain vigilant about the potential for personal injury.

-  **DANGER:** Ignoring these hazards can result in death, severe personal injury, or significant property damage.
-  **WARNING:** Indicates potential hazards that can result in severe personal injury, death, or significant property damage. Ignoring these warnings presents a real danger.
-  **CAUTION:** Indicates potential hazards that can result in minor or moderate personal injury, property damage, or actions that are unpredictable and unsafe. Ignoring these cautions presents a potential hazard.
-  **NOTE:** This label indicates important special instructions that are not directly related to hazards.

USE OF NON-XTREMEPOWERUS REPLACEMENT PARTS VOIDS WARRANTY

ATTENTION INSTALLER: This manual contains vital information regarding the installation, operation, and safe use of this product. It is essential to provide this manual to the end user of the product. Failure to read and follow all instructions could lead to severe injuries.

 **DANGER** Failure to comply with all instructions and warnings may lead to severe bodily injury or even death. It is strongly recommended that only a qualified pool service professional install and service this product. Prior to using this product, installers, operators, and owners must carefully review these warnings and all instructions provided in the owner's manual. It is essential to leave these warnings and the owner's manual with the pool owner for their reference and safety.

 **WARNING** For safety reasons, children should not be allowed to use this product.

IMPORTANT SAFETY INSTRUCTIONS

⚠ DANGER Risk of electrical shock. Connect this product solely to a branch circuit that is safeguarded by a ground-fault circuit interrupter (GFCI). If you are unable to confirm the presence of a GFCI protection on the circuit, please seek assistance from a qualified electrician.

⚠ WARNING Please note that this unit must only be connected to a supply circuit protected by a ground-fault circuit-interrupter (GFCI). The installation of a GFCI is the responsibility of the installer, and it should be regularly tested for proper functioning. To test the GFCI breaker, simply press the test button, which should interrupt power. Pressing the reset button should restore power. If the GFCI fails to operate as described, it is defective and should be replaced. If the GFCI interrupts power to the pump without pressing the test button, it indicates the presence of a ground current and the possibility of electric shock. In such cases, do not use the pump. Disconnect it immediately and seek the expertise of a qualified service representative to address and rectify the issue before resuming use (to test the GFCI breaker).

⚠ WARNING This product is specifically designed for use with permanent swimming pools and, if appropriately marked, can also be used with hot tubs and spas. However, it should not be used with storable pools. A permanently installed pool is one that is built in or on the ground, or within a building, making it incapable of being easily disassembled for storage. On the other hand, a storable pool is designed to be disassembled and reassembled for storage while maintaining its original integrity. Please ensure that this product is only used with permanent swimming pools and hot tubs or spas if appropriately indicated. Avoid using it with storable pools to prevent potential hazards and ensure optimal performance.

IMPORTANT SAFETY INSTRUCTIONS

GENERAL SAFETY

WARNING

- The pump and sand filter system is not designed to be submersible.
- Do not attempt to open the inside of the drive or motor enclosure, as there is a capacitor bank that can retain a potentially dangerous electrical charge, even when the unit is not powered.
- Disconnect the main power plug to turn off the pump before performing any maintenance on the pump and sand filter system.
- Before working on the filter, disconnect the power plug to the pump and release the air pressure to the filter tank.
- The sand filter is designed to operate with water temperatures between +32.0°F to +113.0°F (+0°C to +45°C). Operating the filter outside of this temperature range may cause damage.
- Chemical spills can damage pools/spas and malfunction equipment, risking injury or property harm. Avoid storing chemicals near equipment.
- This appliance is not intended for use by individuals (including children) with reduced physical, sensory, or mental capabilities, or those lacking experience and knowledge, unless they have received supervision or instruction regarding its safe usage from a responsible person.

WARNING

- During installation, ensure proper drainage around the pump to prevent water from entering the electrical components.
- To ensure optimal performance, it is crucial to use the proper size pump for the specific application and install it correctly. Only through meticulous sizing and installation can the pump function as intended.
- The use of pumps that are improperly sized, installed, or employed for applications other than their intended purpose can lead to severe personal injury or even death. These risks encompass potential hazards such as electric shock, fire, flooding, suction entrapment, or critical injuries and property damage resulting from structural failures of the pump or other system components. It is essential to strictly adhere to the correct sizing, installation, and designated usage to mitigate these potential dangers and ensure the safety of all users and the surrounding environment.

DANGER

The pump has the potential to generate significant levels of suction within the plumbing system's suction side. This heightened suction presents a considerable risk if individuals come too close to the suction openings. Being near these openings can result in severe injuries caused by the intense vacuum or may lead to entrapment and drowning.

IMPORTANT SAFETY INSTRUCTIONS



SUCTION ENTRAPMENT HAZARD

! WARNING

To minimize the risk of injury caused by suction entrapment hazards, please follow these safety guidelines:

- Use only properly installed and secured ANSI/ASME A112.19.8 approved anti-entrapment suction covers for each drain.
- Ensure that each suction cover is installed at least three (3') feet apart, measured from the nearest point to nearest point.
- Regularly check all suction covers for cracks, damage, and excessive weathering.
- Promptly replace any loose, cracked, damaged, broken, or missing cover with an appropriate certified one.
- Periodically replace drain covers as necessary since they deteriorate over time due to exposure to sunlight and weather.
- Avoid placing hair, limbs, or your body near any suction cover, pool drain, or outlet.

! WARNING

By adhering to these precautionary measures, you can significantly reduce the risk of injury associated with suction entrapment hazards.

OVERVIEW (PRODUCT INFORMATION)

OVERVIEW (PRODUCT INFORMATION) PACKAGE CONTENTS

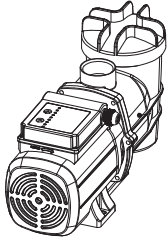

PARTS # 6
PUMP WITH STRAINER
1 PC(S)

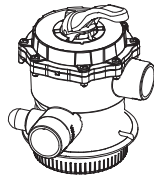

PARTS # 1
7-WAY VALVE
1 PC(S)

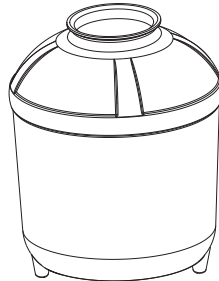

PARTS # 13
FILTER TANK
1 PC(S)



PARTS # 10
**MEDIA ASSEMBLY
LATERAL**
8 PC(S)

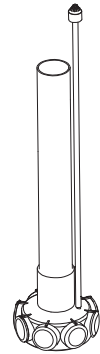

PARTS # 11 & 14
**MEDIA ASSEMBLY
W/ AIR RELEASE**
1 SET(S)

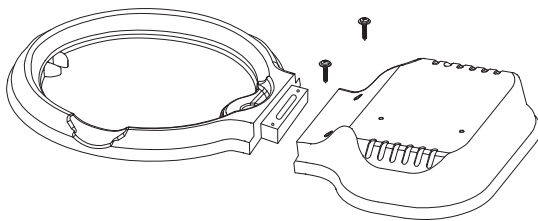

PARTS # 8
SUPPORT BASE
1 SET(S)

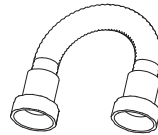

1.5 FT
PARTS # 2
SHORT HOSE
1 SET(S)

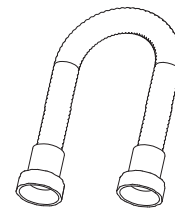

5.4 FT
PARTS # 12
LONG HOSE
2 SET(S)



PARTS # 3
GASKET
5 PC(S)

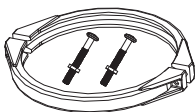

PARTS # 16
FLANGE CLAMP
1 SET(S)



PARTS # 17
FUNNEL
1 PC(S)



PARTS # 15
LARGE O-RING
1 PC(S)



PARTS # 5
SMALL O-RING
2 PC(S)



PARTS # 4
CONNECTOR
2 PC(S)



PARTS # 7
SCREW
2 PC(S)



PARTS # 9
DRAIN PLUG
1 SET(S)

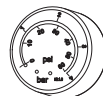

PARTS # 18
PRESSURE GAUGE
1 PC(S)



PARTS
TEFLON TAPE
1 PC(S)



PARTS
USER'S GUIDE
1 PC(S)

OVERVIEW (PRODUCT INFORMATION)

PUMP AND SAND FILTER SYSTEM

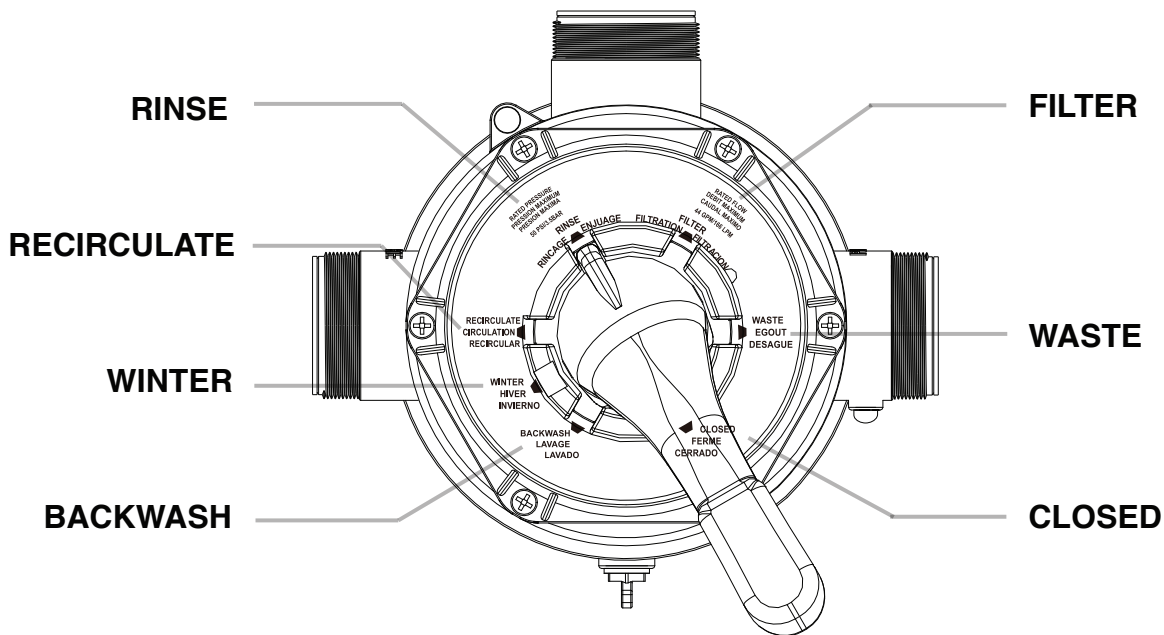
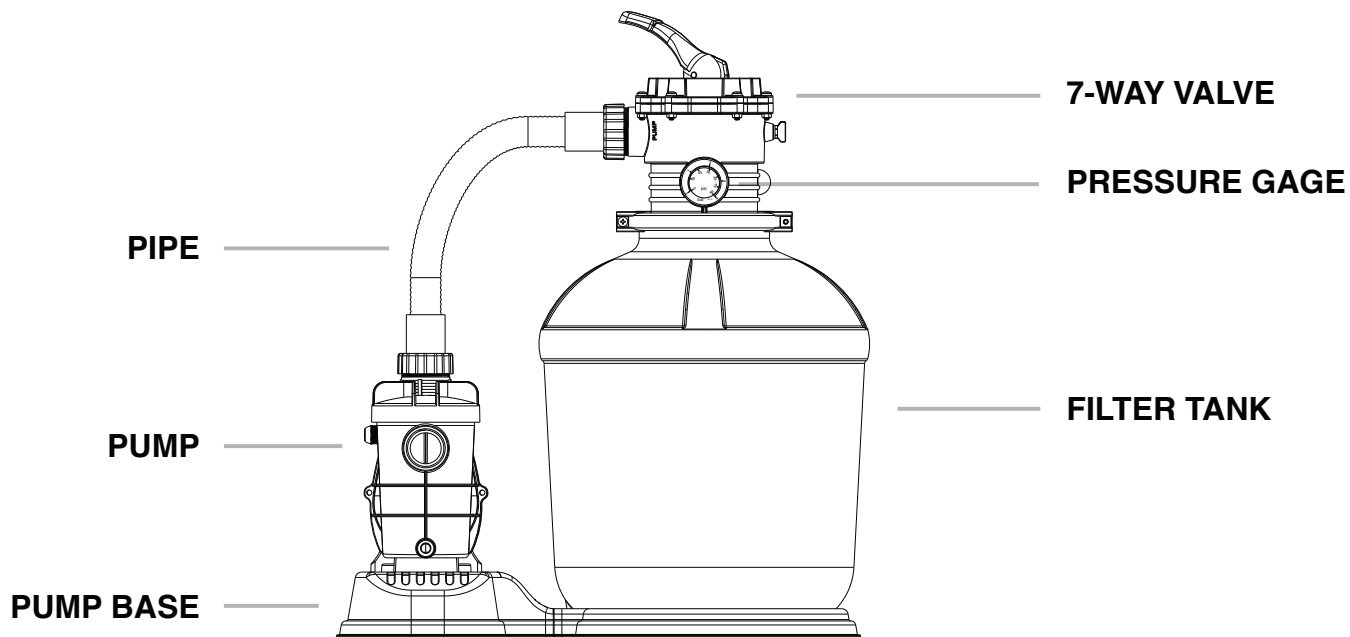

OVERVIEW (PRODUCT INFORMATION)

PRODUCT DIMENSIONS

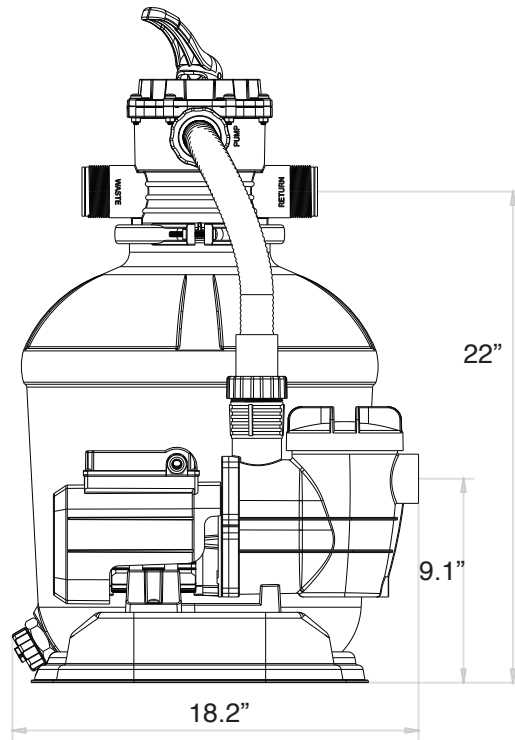
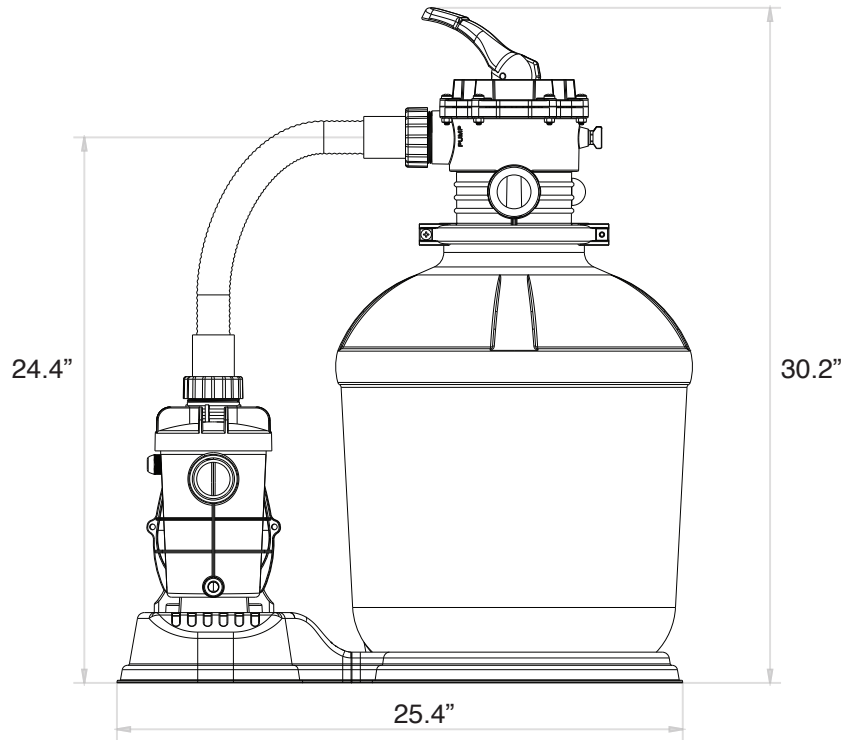

OVERVIEW (PRODUCT INFORMATION)

SPECIFICATIONS

INPUT VOLTAGE	110 V
FREQUENCY	60 HZ
SPEED	SINGLE SPEED
RPM	3450 RPM
HORSEPOWER	0.75 HP
WIRE	PLUG
MAXIMUM CONTINUOUS LOAD	530 W
AMBIENT CONDITIONS	-40°F TO 140°F (-40°C TO 60°C)
STORAGE	32°F TO 122°F (0°C TO 50°C)
OPERATING HUMIDITY	RELATIVE 0 TO 95 % NON-CONDENSING
POOL TYPE	ABOVE-GROUND
HMAX (MAXIMUM HEAD)	36 FT
QMAX (MAXIMUM FLOWRATE)	41.5 GPM
WEF (WEIGHTED ENERGY FACTOR)	4.6
	ETL
CERTIFICATION	DOE
	CEC
FEATURE	THERMAL PROTECTED
	HEAVY-DUTY LONG-LASTING CASE

INSTALLATION

PUMP LOCATION

★ NOTE

- This pump should not be installed within an outer enclosure or beneath the skirt of a hot tub or spa, unless there are specific markings indicating its suitability for such installation.
- It is essential to mechanically secure the pump and sand filter system to the pump base during installation. Proper mechanical securing ensures stability and safe operation of the pump during its use.

Ensure that the pump location satisfies the following requirements:

- Position the pump as close to the pool or spa as feasible. Ensuring it is placed on a dry, well-ventilated surface away from direct sunlight. Consider the following factors:
 - Ensure proper drainage away from the pump.
 - Provide adequate ventilation for the pump motor.
 - Allow easy access for future servicing and winterizing needs.
 - Protect the pump from exposure to the elements.
- Ensure a minimum distance of 5 feet from the inside wall of the pool and spa during installation.
- Keep a minimum distance of 3 feet between the pump and the heater outlet.
- Avoid installing the pump at a location higher than 10 feet above the water level.
- Choose a well-ventilated site for the pump, offering protection from excess moisture, such as rain gutter downspouts or sprinklers.
- Allow a rear clearance of at least 3 inches during installation to enable easy motor removal for maintenance and repair. Refer to **Figure 1** and **Figure 2** for further details.

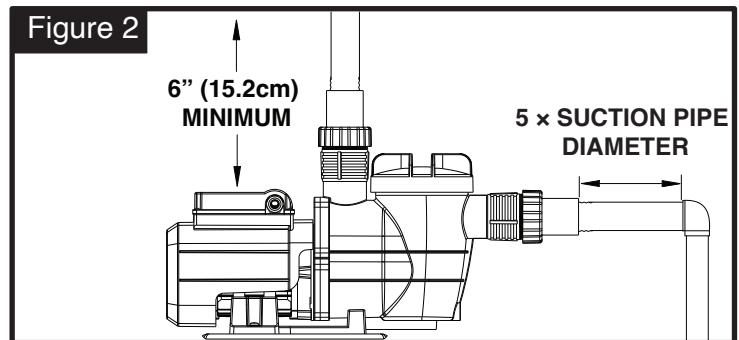
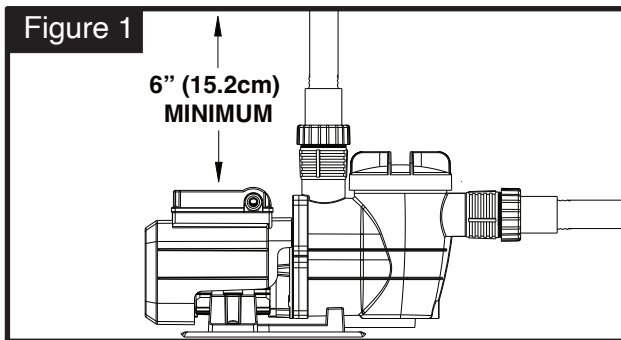

While the pump is designed for outdoor use, it is advisable to position both the pump and filter in the shade to shield them from continuous direct heat. Select a well-drained location that will not flood during rainy periods. Never install the pump and filter in a damp or poorly ventilated area. Keeping the motor clean is crucial, as pump motors require unrestricted air circulation to aid in cooling.

INSTALLATION

ELECTRICAL



RISK OF ELECTRICAL SHOCK OR ELECTROCUTION.

It's crucial to follow the National Electrical Code and all relevant local codes and ordinances. Going against these rules can result in a high risk of electrical shock, potentially leading to severe injury, death, or property damage for individuals involved. To prioritize safety and prevent potential hazards, adhering to electrical safety regulations and guidelines is crucial.

Always ensure the power to the pump is disconnected from the power source before performing any service or maintenance. Failure to do so can lead to severe injury or even death for service personnel, pool users, or others due to electric shock, and may also result in property damage. Prior to servicing the pump, ensure complete disconnection from the power source to ensure the safety of everyone involved and to prevent any potential hazards or accidents.

Prior to commencing any work on the pump, **thoroughly read and familiarize yourself with all servicing instructions.** This practice ensures your understanding of the proper procedures and precautions necessary for safe and effective pump servicing. Neglecting to do so may result in accidents, injuries, or damage to the pump or surrounding equipment. Prioritize safety by carefully reviewing all instructions before undertaking any maintenance tasks.

INSTALLATION

INSTALLATION INSTRUCTIONS

For detailed guidance on safe installation, please refer to the IMPORTANT SAFETY INSTRUCTIONS. These instructions are vital to ensure the pump is set up correctly, maintaining safety and optimal performance.

STEP 1: PUMP BASE ASSEMBLY

Figure A

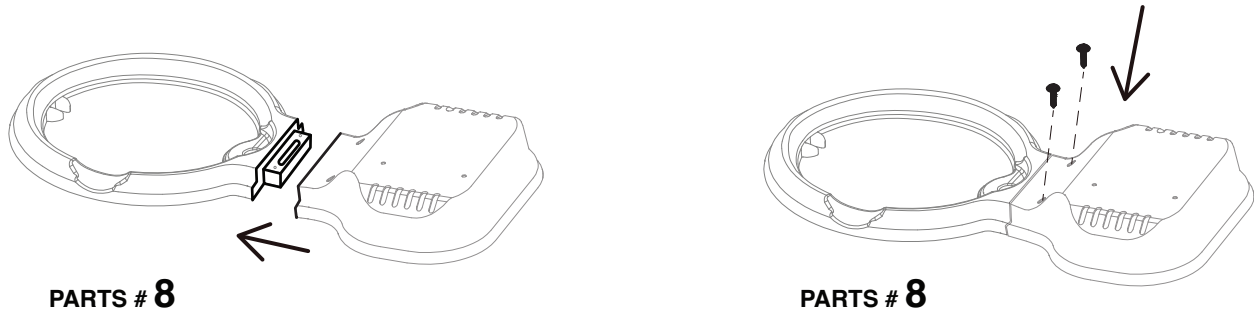
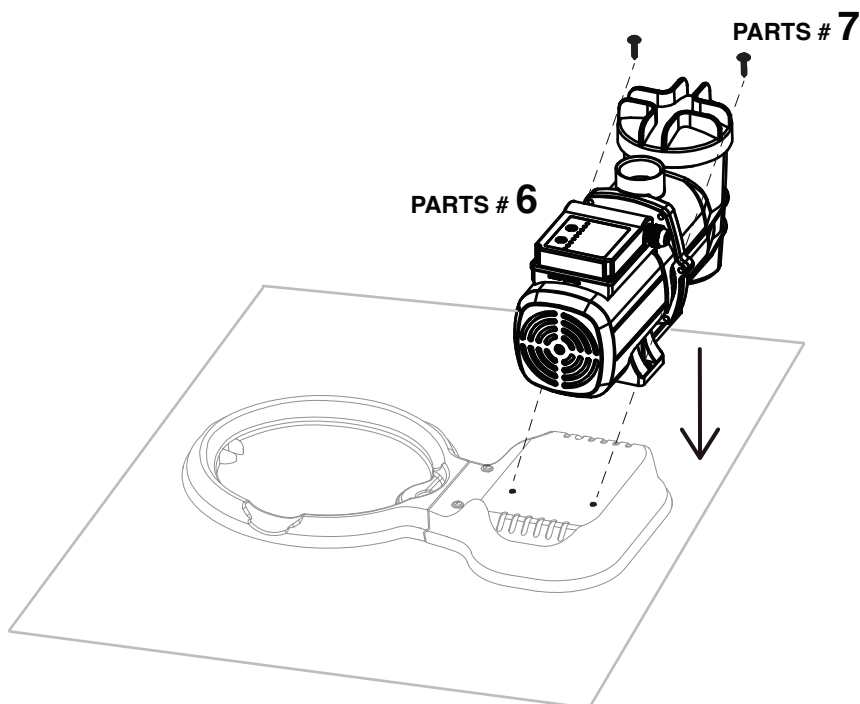

Figure B

★ NOTE

The equipment must be placed on a level surface with adequate ground hardness; if positioned on grass, a flat wooden board should be used as a base for leveling.



INSTALLATION

STEP 2: SAND FILTER DRAIN INSTALLATION

Figure C

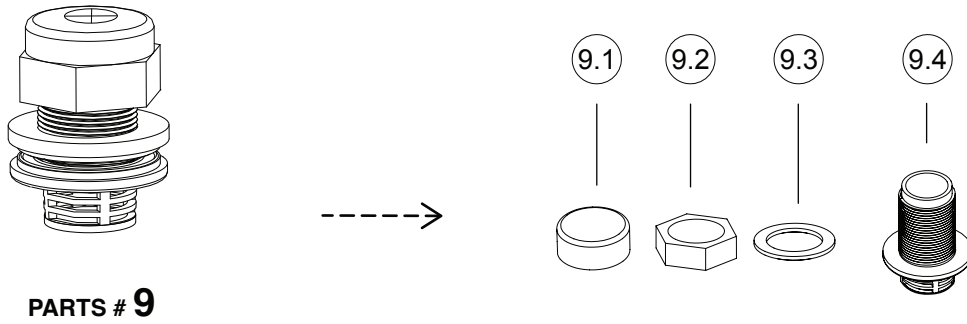
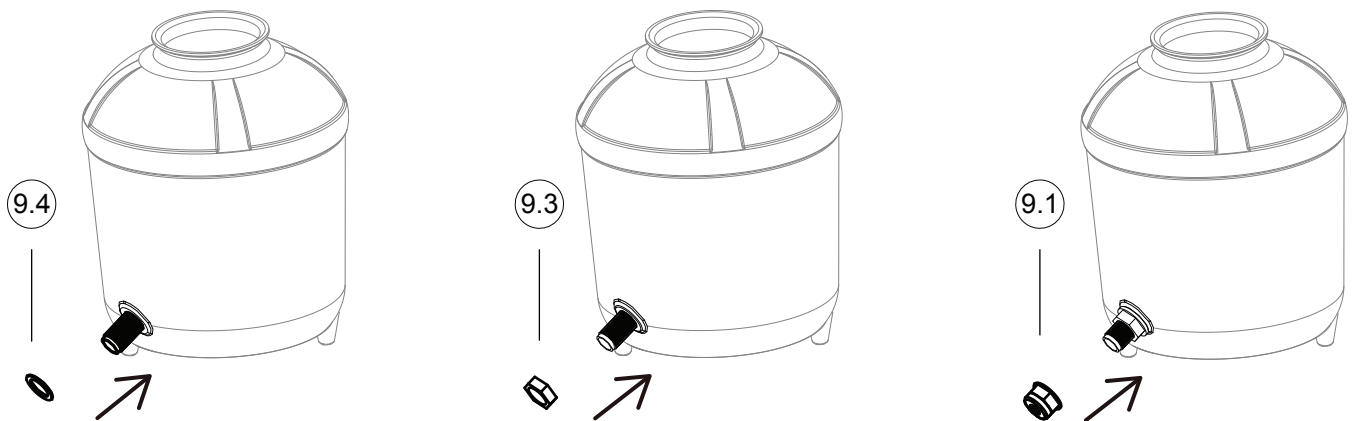
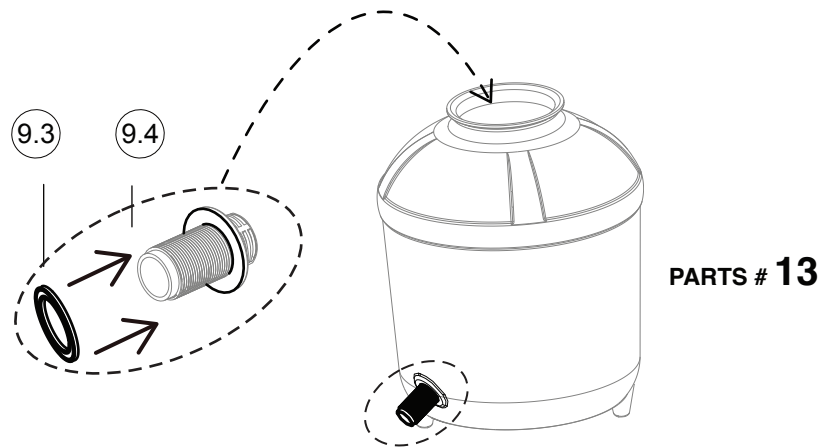

Figure D

★ NOTE

Do not overtighten the components of Part #9.



INSTALLATION

STEP 3: MEDIA ASSEMBLY INSTALLATION

Figure E

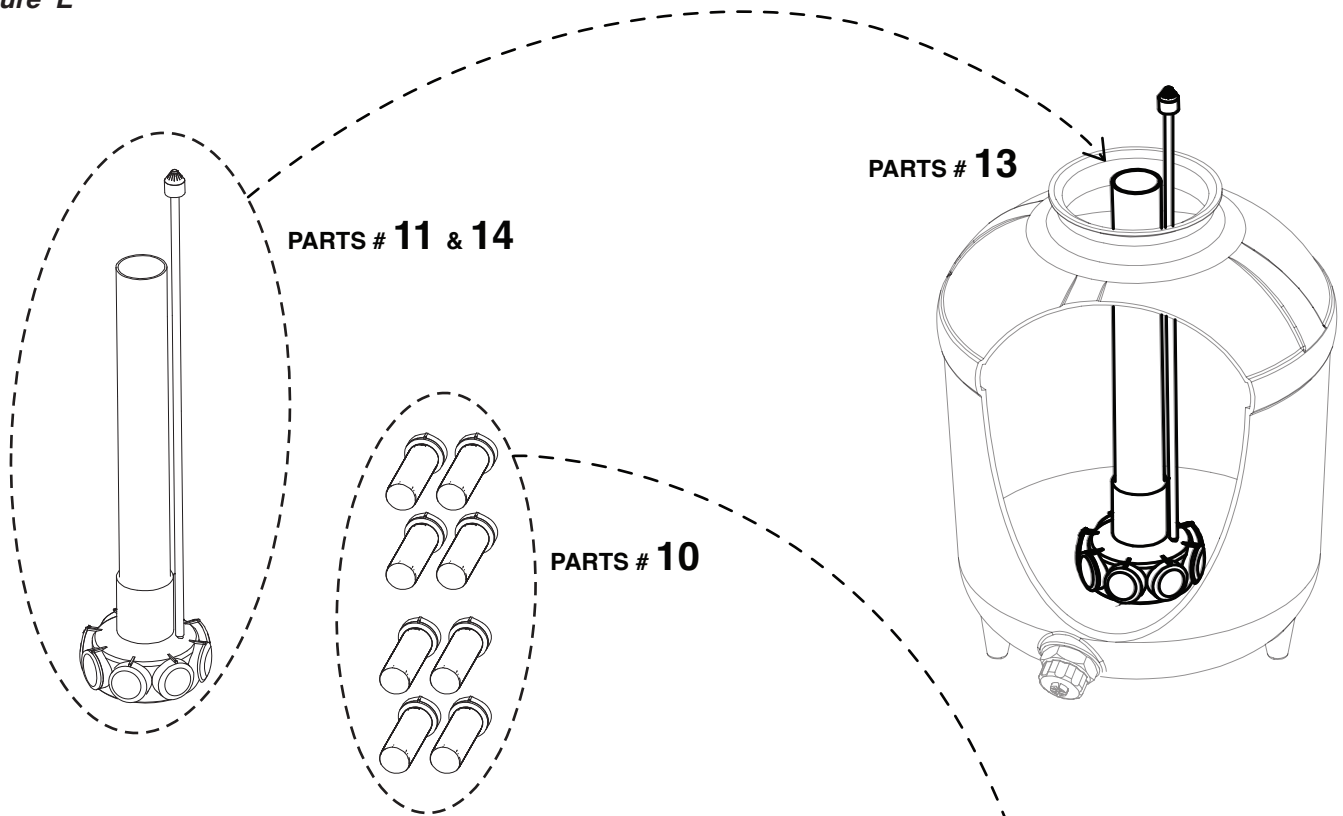
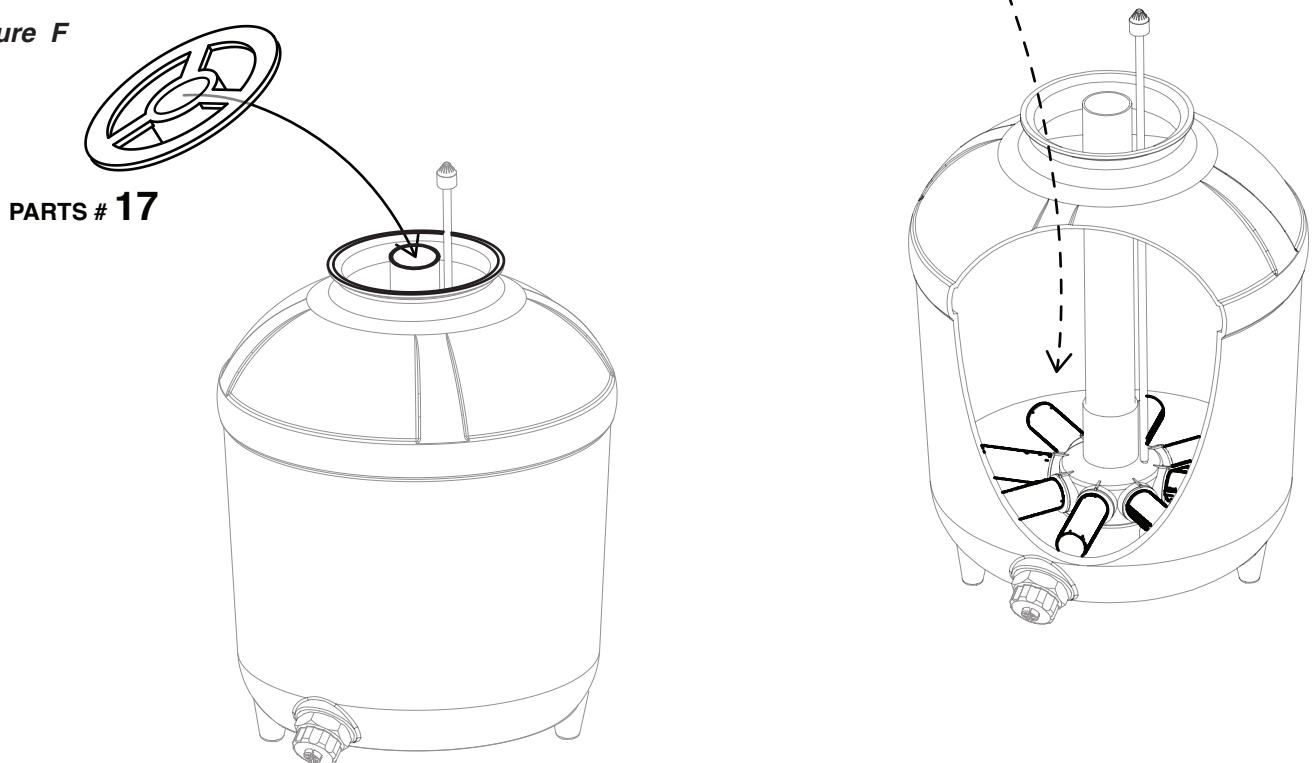

Figure F



INSTALLATION

STEP 4: ADDING FILTER MEDIA

Pool Filter Media Balls

Figure G (filter balls not included)

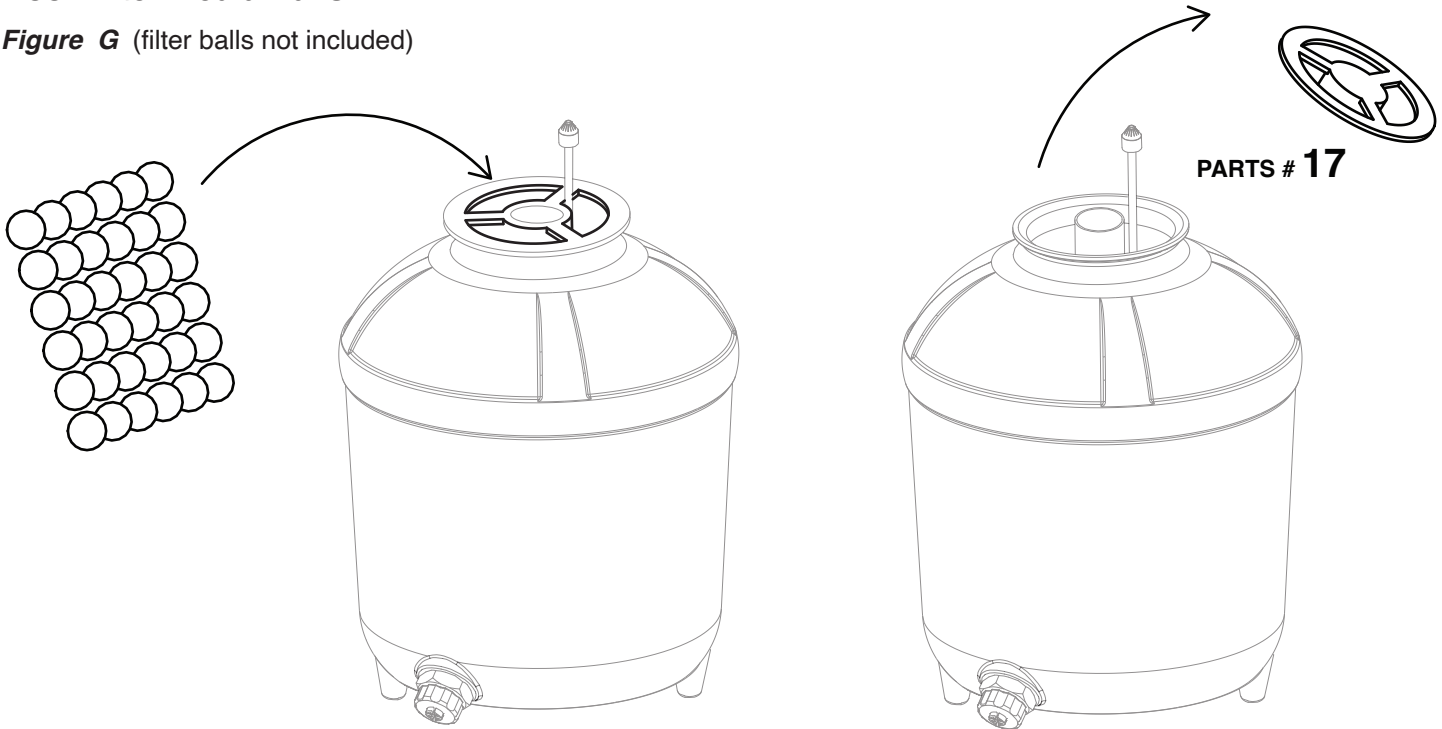

Pool Filter Media Sand

Figure H (filter sand not included)

WARNING Use only **POOL FILTER SAND** for this step.

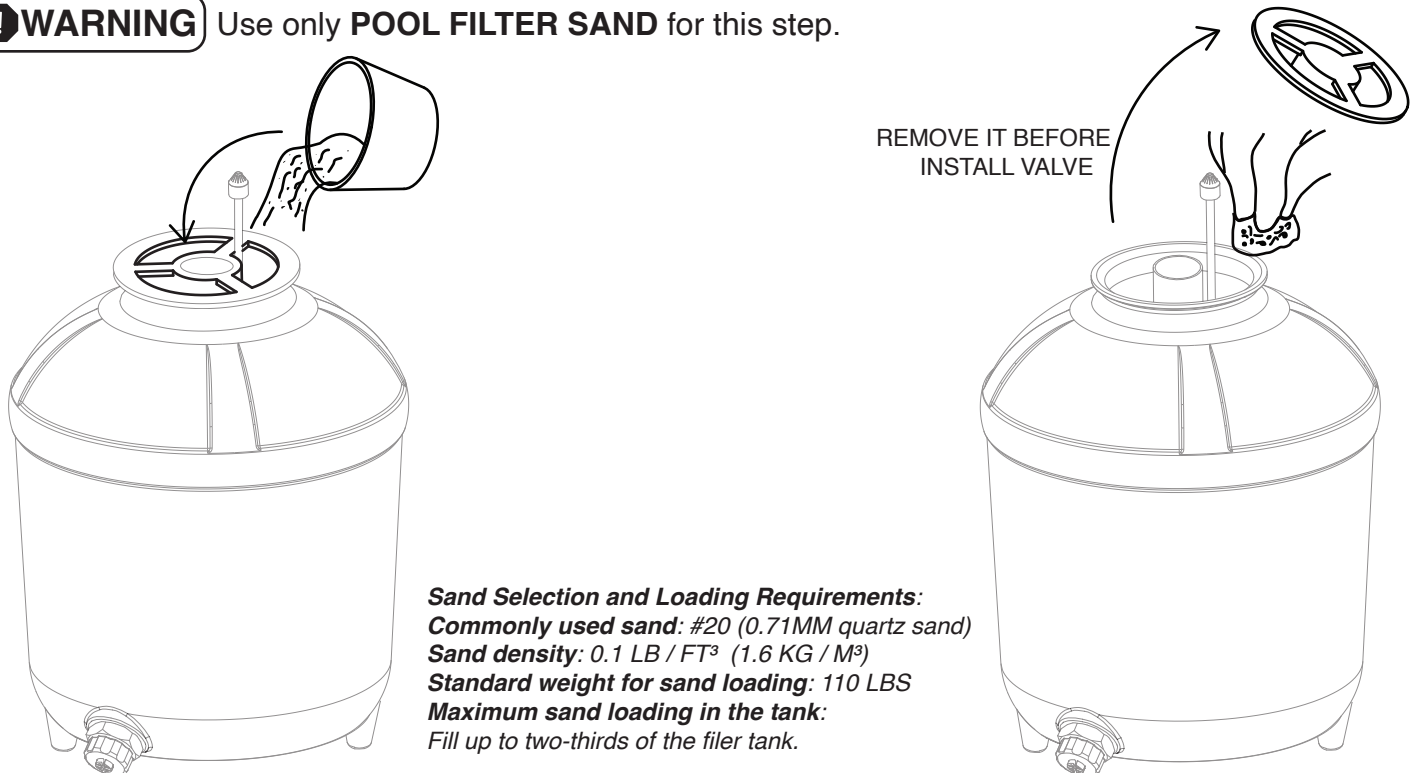

Sand Selection and Loading Requirements:
Commonly used sand: #20 (0.71MM quartz sand)
Sand density: 0.1 LB / FT³ (1.6 KG / M³)
Standard weight for sand loading: 110 LBS
Maximum sand loading in the tank:
Fill up to two-thirds of the filter tank.

INSTALLATION

STEP 5: PRESSURE GAUGE INSTALLATION

Figure I

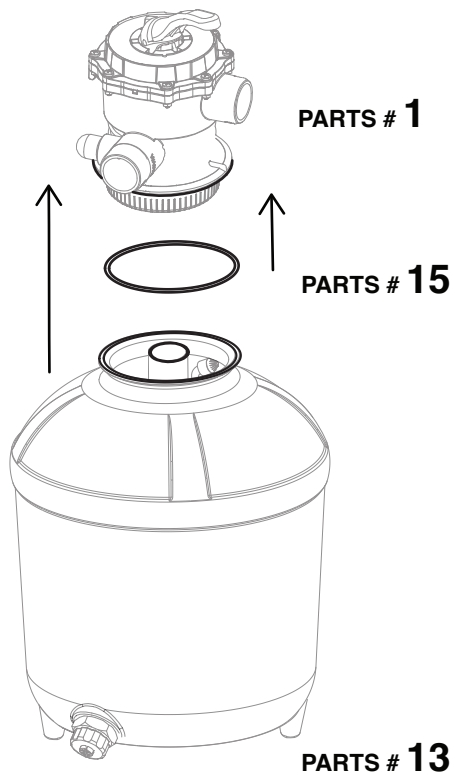

Figure J

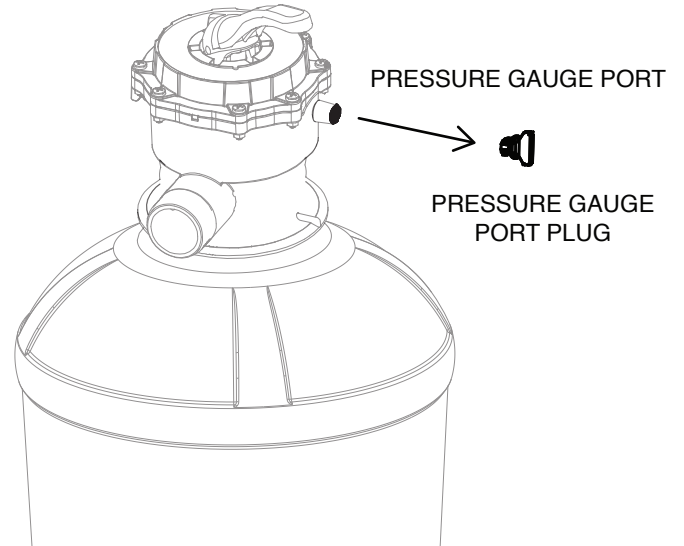

Figure K

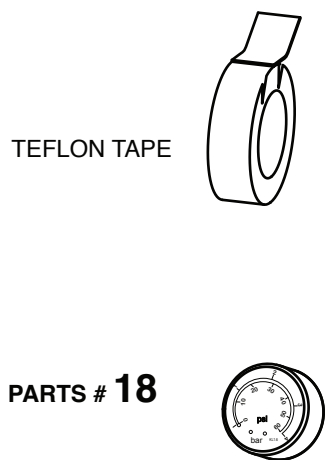
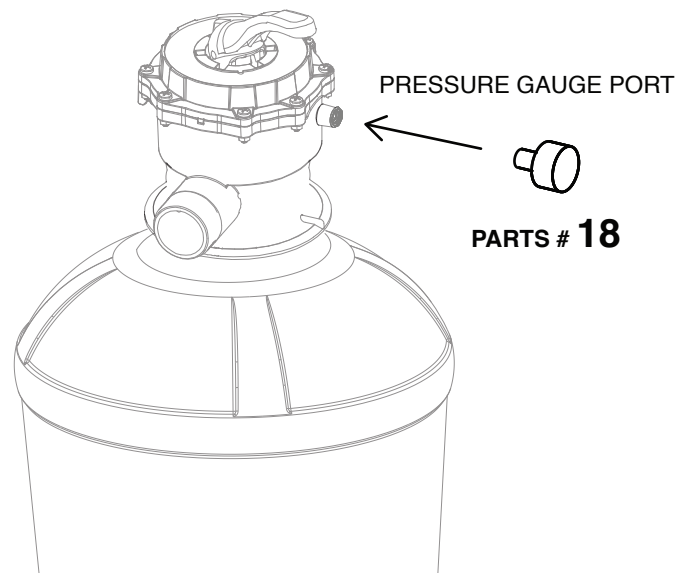

Figure L



INSTALLATION

STEP 6: FLANGE CLAMP INSTALLATION

Figure M

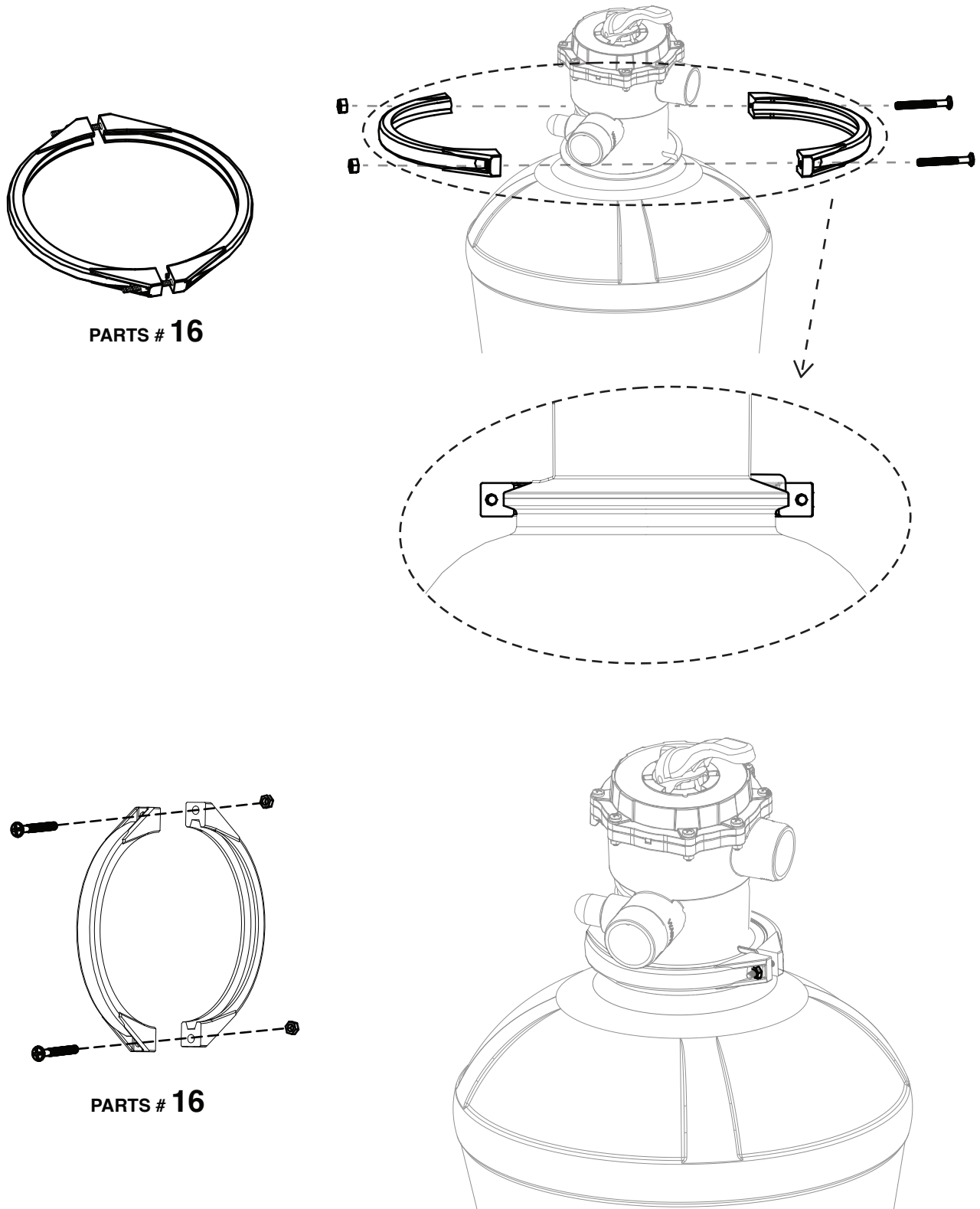

INSTALLATION

STEP 7: TANK ATTACHMENT

Figure N

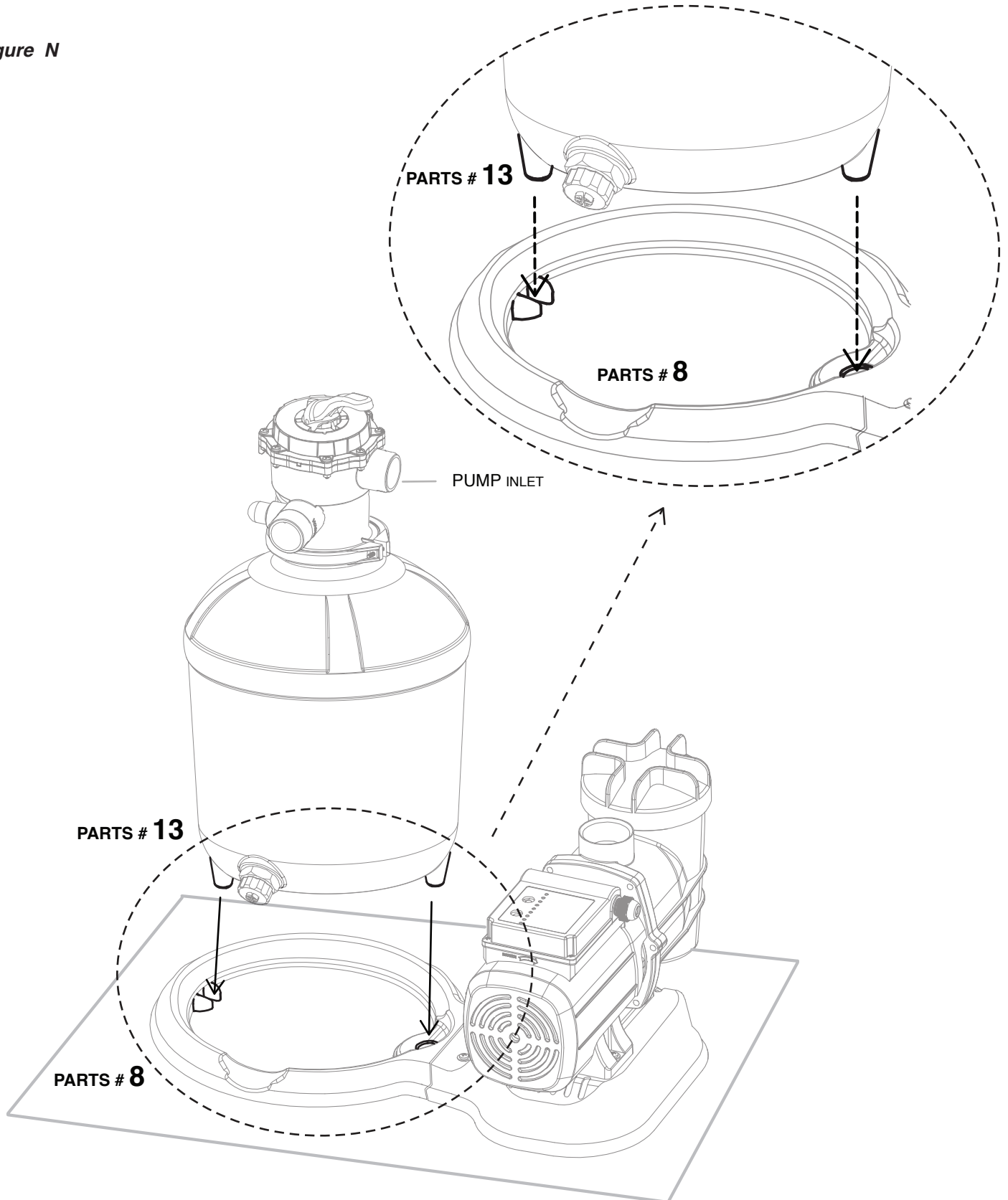

INSTALLATION

STEP 8: HOSE ACCESSORIES ATTACHMENT

Figure 0

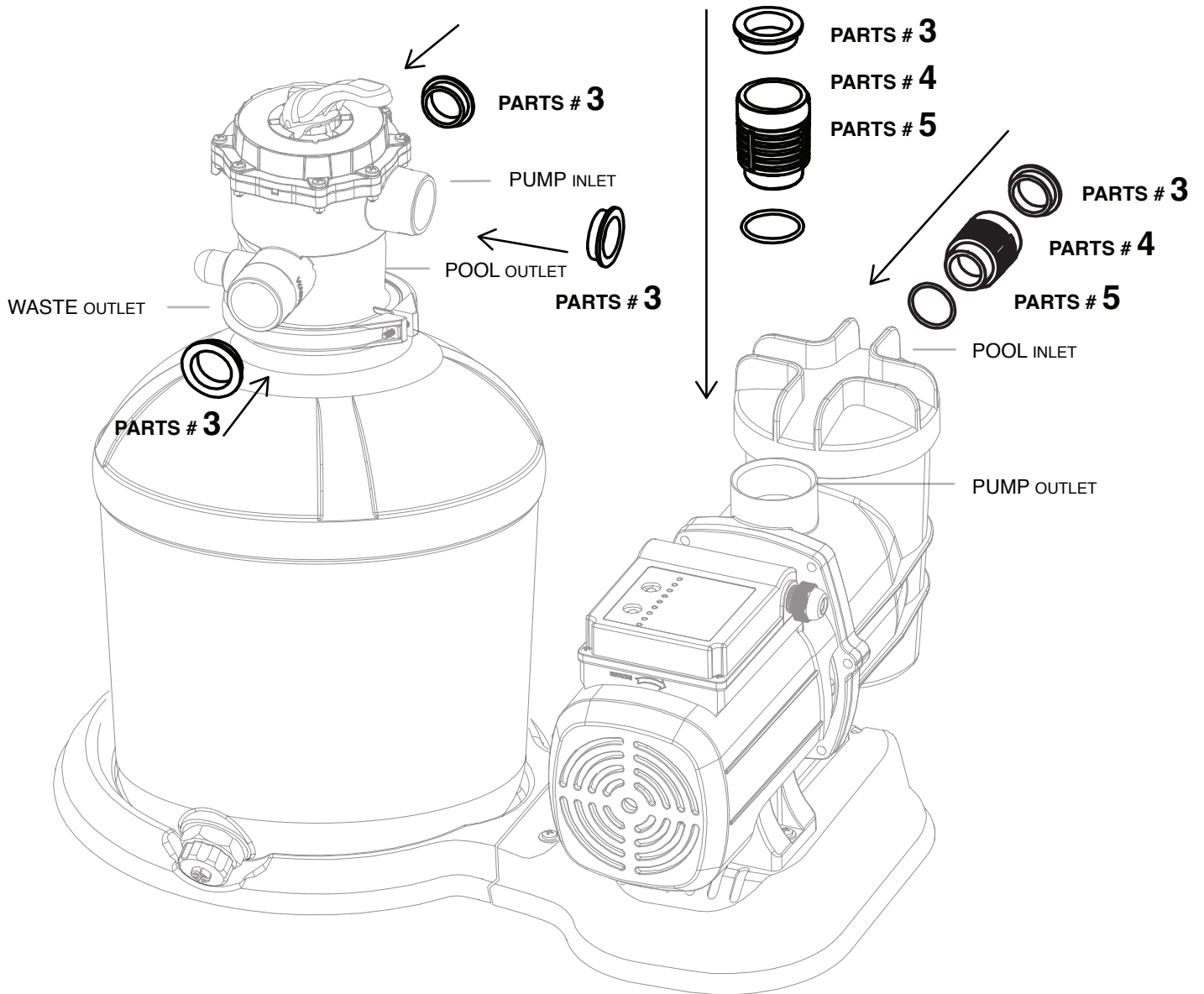

INSTALLATION

STEP 9: HOSE ATTACHMENT

Figure P

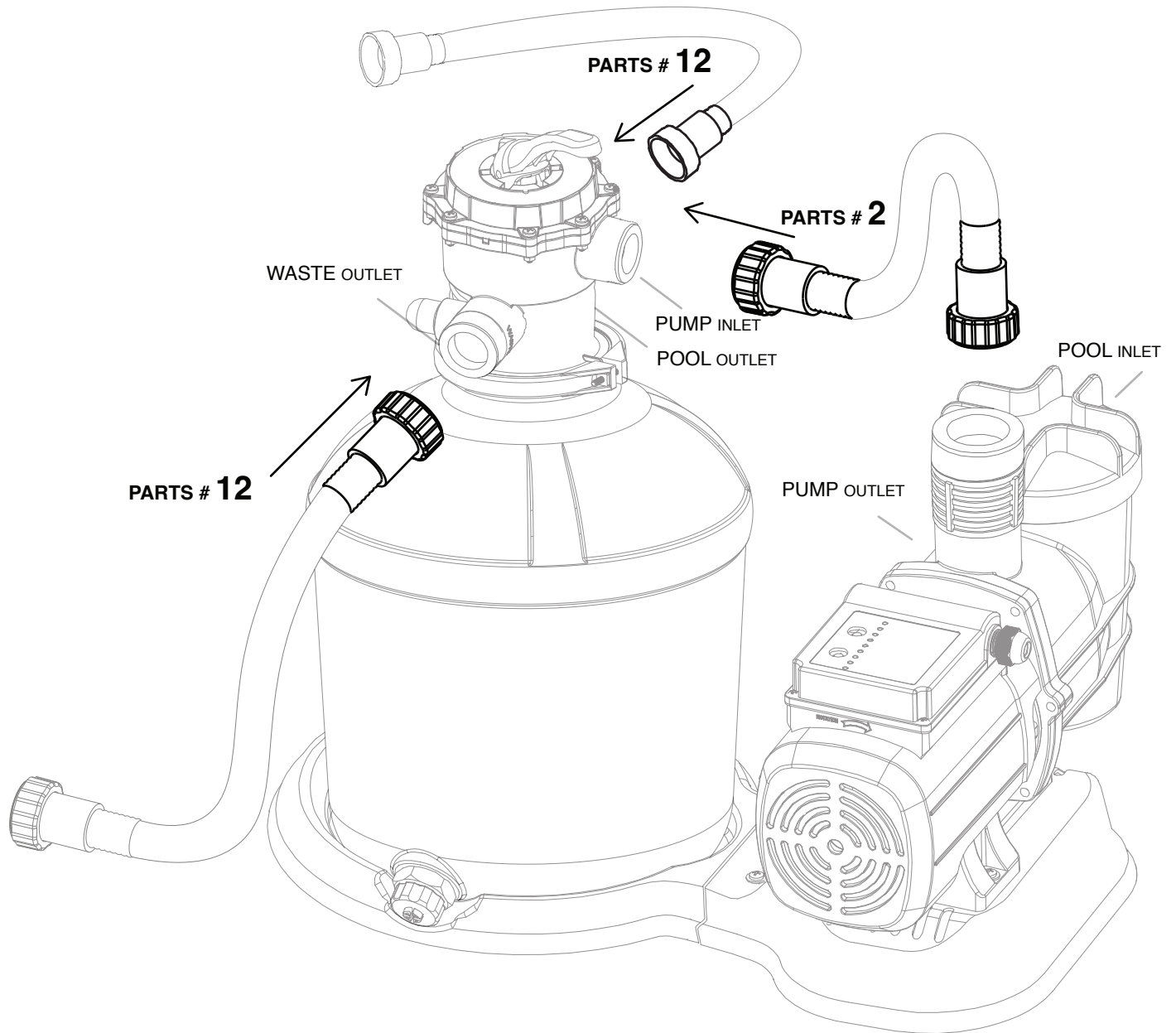

INSTALLATION

STEP 10: POWER CONNECTION

- A. Refer to the details below for the minimum distance in inches between the ground fault protection socket and the pump and sand filter system. (**Figure R**)
- B. Use an **18 AWG** extension cord capable of handling the electrical load of the filter pump.

Figure Q

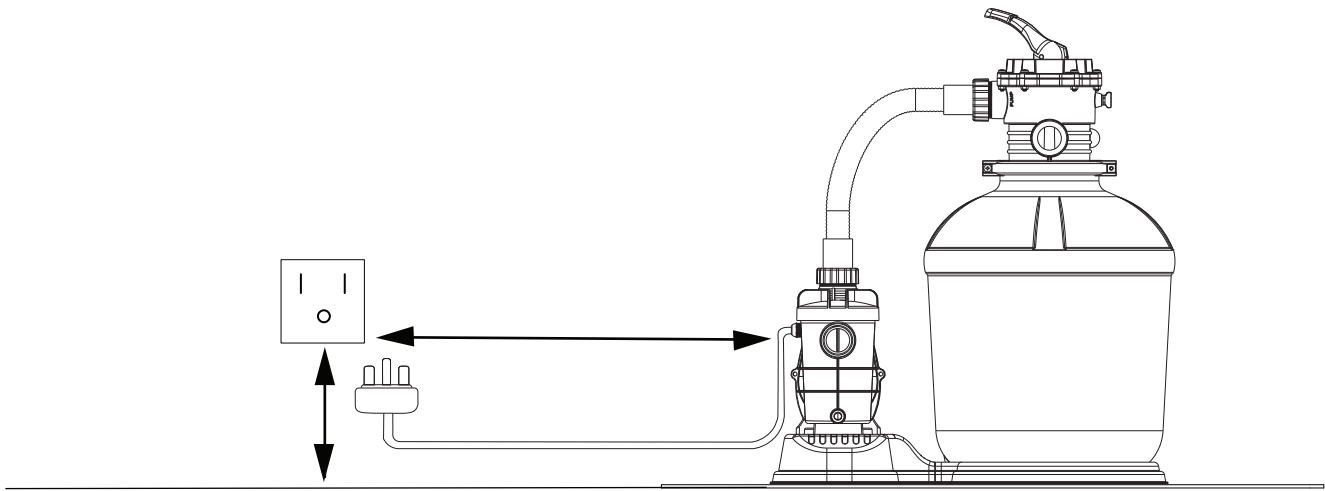

Pump Running Time Suggestion Chart

Pool Capacity (Gallons)	Duration of Each Run (Hours)	Operating Frequency (Hours/Run)
300	0.5	4
600	1.0	4
900	1.5	4
1200	2.0	5
1500	2.5	5
2000	4.0	5
2500	5.0	6
3000	6.0	6

OPERATION

PRIOR TO START-UP

If it is necessary to perform a water pressure test before the initial use to ensure the plumbing system is functioning properly, the following criteria should be followed:

- Engage the services of a professional to perform the water pressure test. Their expertise will ensure accurate and safe testing of the plumbing system.
- Before conducting the test, ensure all XtremepowerUS pump and system components are removed from the plumbing system. This ensures that the test is performed independently of the pump and its components.

⚠ WARNING

If the circulation equipment must remain in the plumbing system during the water pressure test, exercise caution and do not apply more than 10 PSI pressure to the system. Additionally, before removing the pump strainer cover, be sure to release water pressure.

⚠ WARNING

When starting the circulating pump system, ensure that all suction and discharge valves are OPEN, along with the filter air relief valve (if available) on the filter. This critical step is essential for proper pump operation and to prevent potential severe personal injuries.

⚠ CAUTION

Operate with caution: This pump and sand filter system operates simply by plugging in to turn on, and power starts immediately. To turn it off, simply unplug, and power is cut off immediately.

★ NOTE

This pump and sand filter system is designed to work seamlessly with a Swimming Pool Outdoor Programmable Timer outlet, enhancing control and efficiency. Highly recommend using such a timer for optimized performance.

OPERATION

PRIMING THE PUMP

- To begin, fill the strainer housing with water up to the level of the suction pipe. If any water leakage is observed from the pump or filter, DO NOT start the pump. In such cases, it is essential to address the leakage issue before proceeding.
- If no leakage occurs, you may proceed to start the pump. However, ensure that you stand at least 10 feet away from the pump and/or filter after starting it.

⚠ WARNING

Before operating the pump, ensure it has been properly primed as water is essential for cooling and lubricating the seal.

⚠ CAUTION

NEVER OPERATE THE PUMP WITHOUT WATER. Water cools and lubricates the mechanical shaft seal. Running the pump dry can damage the seals, causing leaks, flooding, and voiding the warranty.

⚠ CAUTION

Before removing the strainer cover, follow these steps:

- STOP the pump before proceeding.
- CLOSE the valves in the suction and outlet pipes.
- RELEASE ALL PRESSURE from the pump and piping system.
- After removing the strainer cover, fill the strainer housing with water.
- If necessary, clean and lubricate the strainer cover O-ring with silicone based lubricant.
- Replace the strainer cover on the strainer housing.
- OPEN the suction and outlet pipe valves.
- Refill basket with water.

⚠ DANGER



★ NOTE

Avoid installing 90° elbows directly into the pump inlet or outlet. This will help maintain efficient pump operation.

Priming Instructions:

- Confirm that all connections are secure.
- Clean the pool thoroughly before filling to avoid damage to the pump and filter from excessive dirt and large particles.

⚠ WARNING

- Ensure all suction and discharge valves are fully open before starting the system.
- Failure to do so could result in severe personal injury.
- Before starting the pump, make sure the filter vessel is filled with water.
- Starting the pump without water may cause damage to the pump.

OPERATION

Priming Instructions: (Continued)

- Open all pool suction and WASTE lines for free water flow to the WASTE line. Press down and turn the top mount valve handle to the "BACKWASH" position.
- Inspect the valve clamp for proper tightness.
- Prime and activate the pump to fill the filter tank with water.
- Observe the WASTE line for a steady flow of water. Operate the pump for a minimum of 2 minutes or until the backwash water runs clear, to eliminate impurities and fine sand particles from the media.
- Switch off the pump and adjust the valve to the "RINSE" position. Confirm that all pool suction and WASTE lines are open for unrestricted water flow. Avoid running the sand filter dry. Maintain a safe distance from the filter and start the pump.
- Continue running the pump for at least two minutes.
- Turn off the pump and switch the valve to the "Filtration" position. Check that all pool suction and RETURN lines are open, ensuring free water circulation to and from the pool. Keep clear of the filter and initiate the pump.
- The filter will begin its filtering cycle. Verify that water is circulating back into the pool and record the operating pressure with a clean filter.
- Inspect the system for leaks. In case of a leak, turn off the pump before addressing it.
- Monitor the filter pressure as it cleans the pool water. When the pressure gauge shows a 5-10 PSI (0.34-0.69 BAR, this value may change based on the pool's pump and piping) increase over the initial clean filter reading, initiate the BACKWASH cycle for the filter.

AFTER PRIMING THE PUMP

- Once the pump is primed, turn it on and open all suction and discharge line valves.
- Allow time for the pump to expel air from the suction lines.
- If there's no water flow within five minutes, stop the pump and re-prime it.
- Check for air leaks and refer to the Troubleshooting section if the pump isn't working correctly.

Checking for Air Bubbles:

- After running the pump for about ten minutes, check the return fittings for air bubbles.
- Continuous air bubbles may indicate a leak in the suction line; fix leaks promptly to avoid further problems.

Controlling Output:

- Keep the gate valve in the suction line fully open while the pump is running.
- To adjust the output, if necessary, use a valve on the return line.

WARNING

Never operate the pump with closed suction or discharge valves.

OPERATION

VALVE FUNCTIONS

⚠ CAUTION

Never operate the pump without water.

BACKWASH (Initial Run)

Use this setting to clean the filter. When the filter pressure gauge rises 5-10 PSI (0.034-0.69 BAR, this reading may vary depending on the pool's pump and general piping system) above the start-up clean pressure.

- Turn off the pump and set the valve to the "BACKWASH" position.
- Start the pump and backwash until the water in the sight glass is clear. This usually takes about 2 minutes or less, depending on the amount of dirt accumulated, and then turn off the pump. Proceed to "RINSE".

Figure R

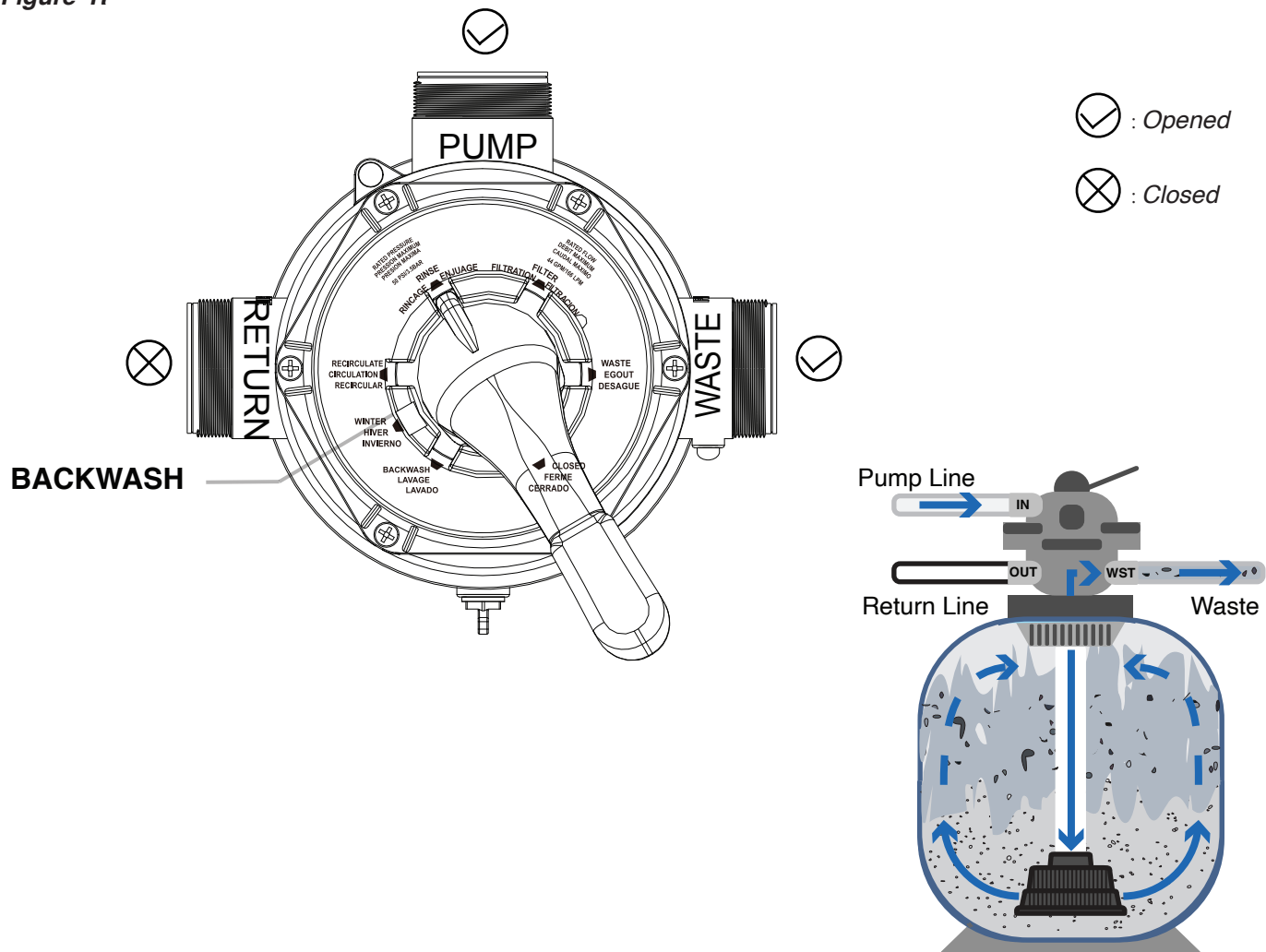

OPERATION

RINSE (Initial Run)

This ensures that all the dirty water from backwashing is rinsed out of the filter and goes to waste, preventing possible return to the pool.

- After backwashing, keep the pump off and set the valve to "RINSE" position and start the pump for about 0.5 to 1 minute.
- During rinsing, discharge water through the drain pipe. After sufficient rinsing, stop the pump, set the valve to "Filtration", and start the pump for normal filtering.

Figure 5

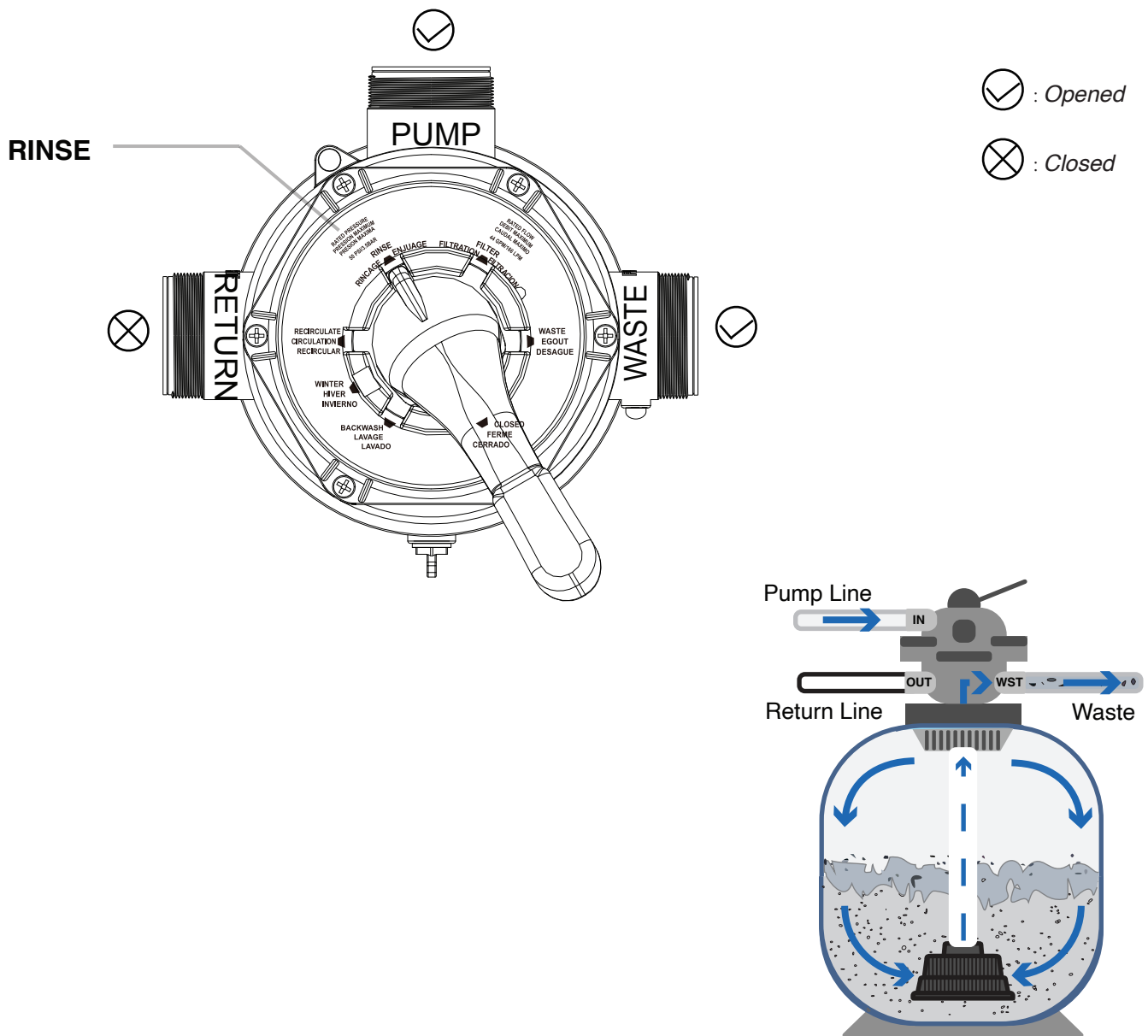

OPERATION

FILTER (Regular Operation)

For normal filtering and regular vacuuming.

- Turn off the pump. Set the valve to the "FILTRATION" position for regular pool filtration. Then, start the pump.
- Occasionally check the pressure gauge to ensure pressure remains within the normal range 5-10 PSI (0.034-0.69 BAR), this reading may vary depending on the pool's pump and general piping system.
- After sufficient filtration, turn off the pump.

Figure T

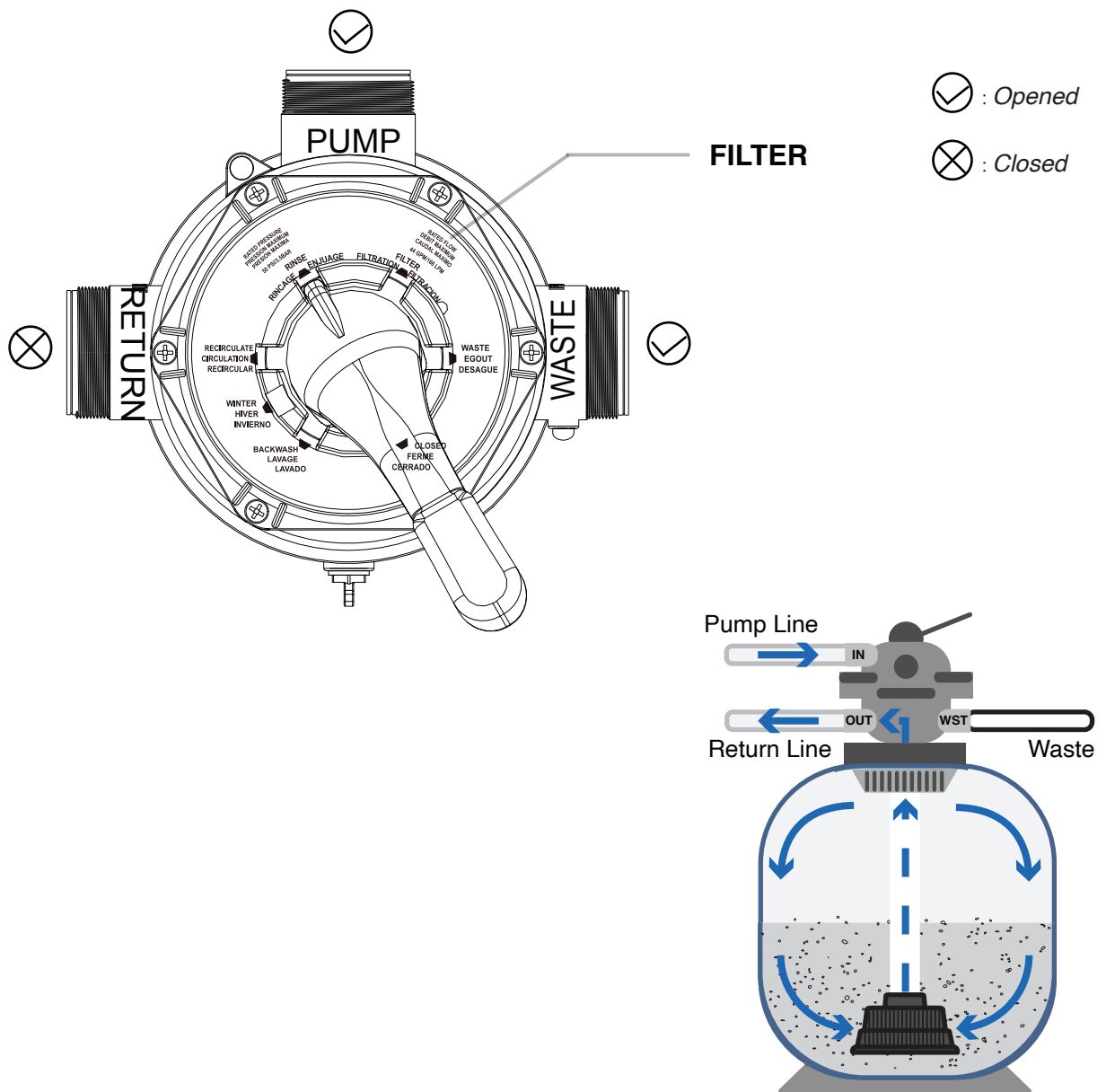

OPERATION

WASTE (Bypass Filter Media For Direct Water Exit)

It enables water to access the filter but avoids passing through the filter media, instead directing it to exit the filtration system entirely. It aids in extracting leaves, dirt, and additional debris.

- With the pump remaining off, set the valve to the "WASTE" position to prevent clogging of the filter while vacuuming the pool. Then start the pump.
- After sufficient flushing, turn off the pump.

Figure V

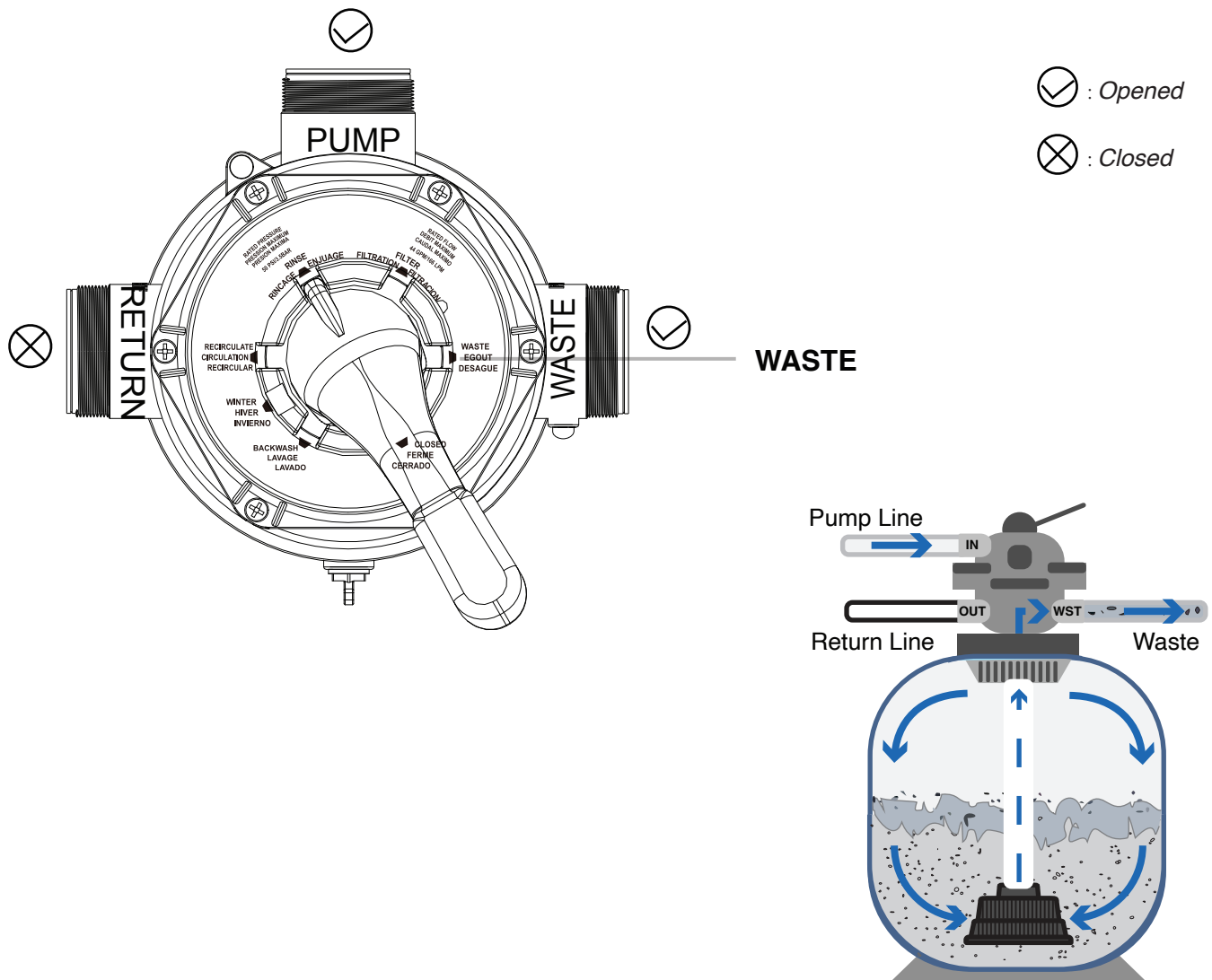

OPERATION

CLOSED (Shut Off The Flow To The Filter and Pool)

⚠ WARNING

Avoid activating the pool pump when the 7-way valve is set to CLOSED, as this could result in damaging the filter, the pump, or both.

This function involves shutting the valve to prevent water from entering, offering utility in clearing the lines during the pool's opening process and during winterization to expel air through the suction lines, redirecting airflow into the pool.

- With the pump remaining off, set the valve to the "CLOSED" position to prevent water from entering.

Figure W

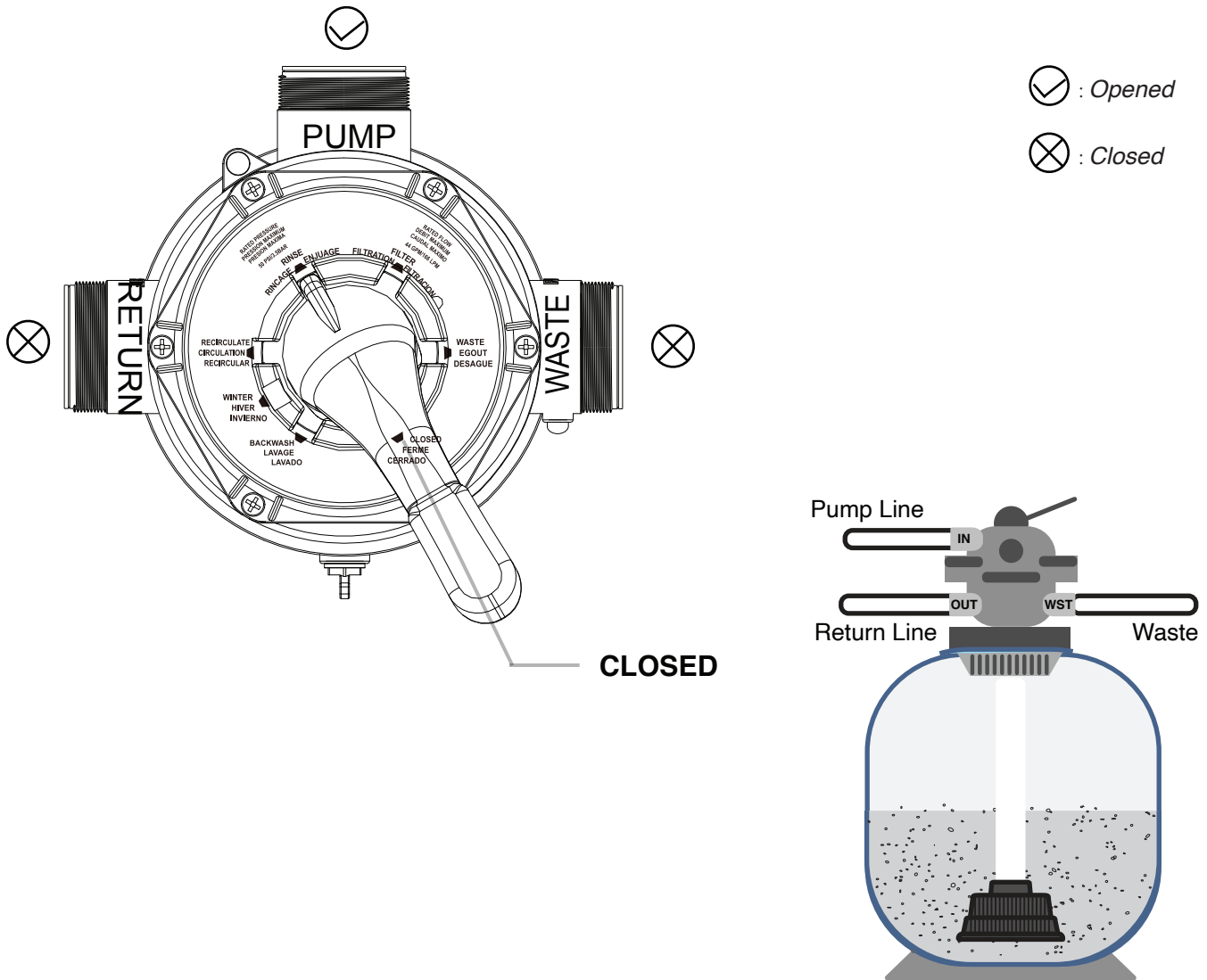

WINTER (For Winterizing) (Continued)

DANGER

Before attempting any corrective actions, ensure that the pump is in the OFF position. To avoid any potential electrical hazards, wait until the remaining power in the capacitor is fully discharged before proceeding with any work on the pump.

- Storing Pump for Winterization
 - Turn off the power for the pump.
 - Drain Water.
 - For Sand Filter
 - Turn the valve to “BACKWASH” for 3 to 5 minutes.
 - Set the valve to “WINTER” position.
 - For Cotton Ball Filter
 - Turn off the pool pump power.
 - Locate and open the drain valve at the bottom of the filter tank.
 - Allow the water to drain from the filter.
 - Close the drain valve once draining is complete.
 - Set the valve to “WINTER” position.
 - Cover the motor to shield it from severe rain, snow, and ice.
 - Avoid wrapping the motor in plastic, as it can lead to condensation and rust on the inside of the motor.

OPERATION

CONTROL PANEL

TIMER SETUP

- Unscrew the 4 screws securing the terminal box lid and remove the lid.
- Take out the battery.
- Carefully remove the protective film from the battery's surface.
- Replace the battery and reapply the rubber film.
- Reattach the terminal box lid and securely tighten the 4 screws.

Figure Y

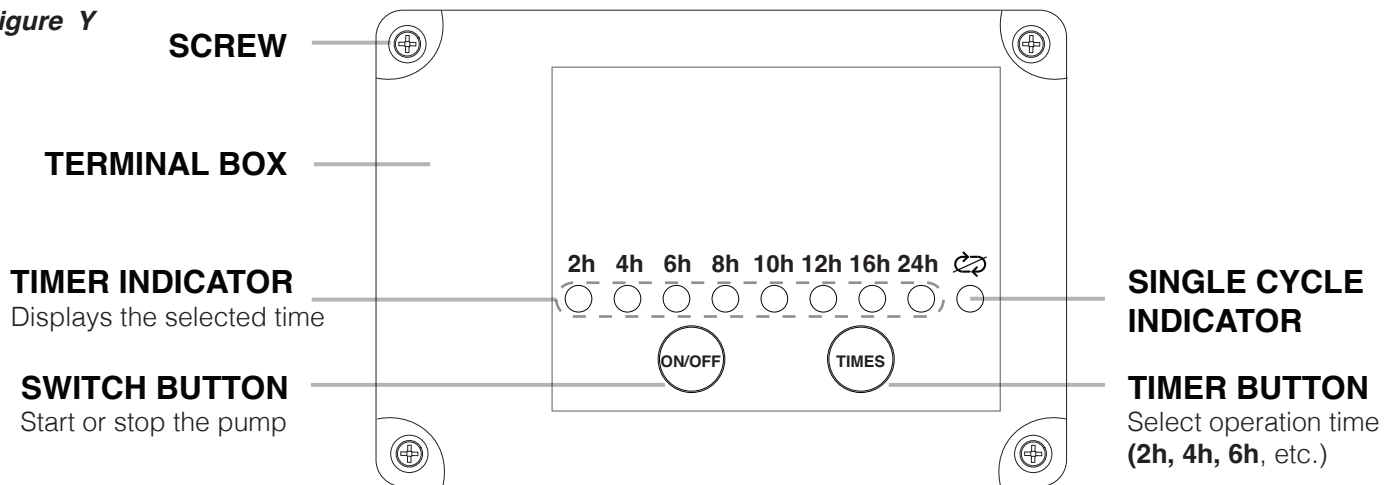

TIMER AND OPERATION MODES

- **Switching to Single Cycle Mode**
 - Hold the TIMER button for 10+ seconds until the single cycle light flashes.
 - Note: The single cycle light won't activate if the 24h timer light is flashing.
 - To adjust time, press the TIME button while the pump is off.
- **Operation Modes**
 - Continuous Mode
 - Default: 24-hour continuous operation (24h light flashing).
 - Custom Time: Press TIMER to select a time (**2h, 4h, 6h**, etc.), then press ON/OFF to start. The pump runs according to the selected time.
 - Example: Set to **4h** at 8:00 AM, the pump runs until 12:00 PM and repeats daily.
 - Single Cycle Mode
 - Activation: Hold TIMER for 10+ seconds until the single cycle light flashes.
 - Operation: The pump runs for the set time, then stops. It restarts only after power is disconnected and reconnected.
 - Example: Set to **4h**, the pump runs 4 hours, stops, and won't restart until power is cycled.

OPERATION

REGULAR INSPECTION AND MAINTENANCE

- **Check Screws**
 - Ensure all screws in the baseboard are securely tightened. Tighten any loose screws.
- **Inspect Power Cords and Insulation**
 - Check for any damage to power cords or insulation parts. If damaged, have a qualified technician repair or replace them to prevent electrical hazards.
- **Overheating**
 - Stop the pump immediately if it overheats. Identify the cause, repair it, and only resume operation once the issue is resolved.
- **Excessive Noise**
 - Stop the pump immediately if it becomes too noisy. Have a qualified technician inspect and repair it. The pump should only be used after repairs.

WARNING

- **Prevent Water Damage:**
 - Do not allow water to enter the motor or other electrical components.
- **Damaged Wires:**
 - Replace damaged wires immediately to prevent electric shock. Ensure wires are positioned safely, away from equipment like lawnmowers or pruning shears.
- **Power Disconnection:**
 - Before separating the pump, disconnect the power supply and wait until the pump has completely stopped.
- **Pre-Start Check:**
 - Ensure the power is connected correctly and there is no damage to the power cord or insulation before starting the pump.
- **Power Off Before Draining:**
 - Always cut off the power before draining the pump to avoid electric shock.

TROUBLESHOOTING

TROUBLESHOOTING



Turn the pump OFF and disconnect the power source before any corrective work. Wait for the pump's capacitor to discharge completely to prevent electrical hazards.

ISSUE	CAUSE	CORRECTIVE ACTION
Pump Won't Start	Improper or loose wiring connections; open switches or relays	Check all connections
	Tripped circuit breakers	Reset tripped breakers
	Blown fuses.	Replace blown fuses in the Circuit Breakers (Applies to older homes)
	Mechanical binding and electrical overload	Manually check rotation of motor shaft for free movement with no obstruction
	Using a pump timer	If using a pump timer try overriding, it to ensure the pump is receiving power. Also check the rocker switch on the back of the pump to confirm the power is on either high or low speed so that the timer can turn the pump on and off to the set speed
Pump Starts then Stops	Undersized wiring	Contact qualified professional to check that the wiring gauge is heavy enough. The wiring should be at least AWG14
	Loose connections	Check all connections
	Low voltage at motor or power drop (frequently caused by undersized wiring or extension cord use)	Contact qualified professional to check that the wiring gauge is heavy enough. The wiring should be at least AWG14
	Overheating	The pump shouldn't be running for more than 8 hours a day. Ensure that it is either well shaded or run during the cooler times of the day to prevent the bearings from drying out quickly.
	Mechanical binding	Manually check rotation of motor shaft for free movement with no obstruction
	Electrical overload	Ensure proper grounding and wiring voltage.

TROUBLESHOOTING

ISSUE	CAUSE	CORRECTIVE ACTION
Pump Hums but will Not Start	Incorrect Voltage	Check input voltage and wiring connection
	Incorrect Wiring	Check wiring connections
	Mechanical binding	Manually check rotation of motor shaft for free movement with no obstruction
	Pump Ran Dry	Ensure that the pump is properly primed before its first use. Also, check for any leaks at the connections or in your pipes. The pump basket should always be full while the pump is running;
	Capacitor failure	Have the capacitor tested by a pool pump repair company.
Pump Won't Prime	Pump Ran Dry	Ensure that the pump is properly primed before its first use. Also, check for any leaks at the connections or in your pipes. The pump basket should always be full while the pump is running; any loss of water in the basket while running or when the pump turns off indicates a leak somewhere. A backflow device can be installed in the suction line of the pool pipes if needed.
	Empty pump/strainer housing.	Make sure pump/strainer housing is filled with water and cover O-ring is clean. Ensure O-ring is properly seated in the cover O-ring groove. Ensure O-ring is lubricated, and that strainer cover is locked firmly in position. Lubricant will help to create a tighter seal. Lubricant will help to create a tighter seal. Fill with water and observe carefully to check for any leaks.
	Loose connections on suction side and/or outlet side.	Tighten pipe/union connections. (Any self-priming pump will not prime if there are suction air leaks. Leaks will result in bubbles emanating from return fittings on the pool wall or in the strainer basket.)
	Leaking O-ring or packing glands on valves.	Tighten, repair, or replace valves.
	Strainer basket or skimmer basket loaded with debris.	Remove strainer housing cover or skimmer cover, clean basket, and refill strainer housing with water. Tighten cover. (If strainer is equipped.)

TROUBLESHOOTING

ISSUE	CAUSE	CORRECTIVE ACTION
Pump Won't Prime (Cont)	Suction side clogged.	<p>Contact a qualified repair professional.</p> <p>Block off the bottom port of the skimmer to determine if pump will develop a vacuum. You should have 5"-6" of vacuum at the strainer cover (Only your Pool dealer can confirm this with a vacuum gauge). You may be able to check by removing the skimmer basket and holding your hand over the bottom port with skimmer full and pump running. If no suction is felt, check for line blockage. (If strainer is equipped.)</p> <ul style="list-style-type: none"> A. If pump develops a vacuum, check for blocked suction line. An air leak in the suction piping may be the cause. B. If pump does not develop a vacuum and pump has sufficient "priming water": <ul style="list-style-type: none"> a. Re-check housing cover and all threaded connections for suction leaks. Disconnect from the breaker and check if all system hose clamps are tight. b. Check voltage to ensure that the motor is rotating at full RPM's. c. Open housing cover and check for clogging or obstruction in suction. Check impeller for debris. Remove and replace shaft seal only if it is leaking.
Low Flow	Clogged or restricted pipe (line) and / or outlet line.	Contact a qualified repair professional.
Low Flow	The pump's location is either too high above the pool water level and/or too far from the pool.	Make sure that the pump height and lines are not further than the manufacturer's recommended maximum distance.
Low Flow	Undersized pool piping.	Correct piping size.
Low Flow	Plugged or restricted discharge line of filter, valve partially closed (high gauge reading).	Sand filters – backwash as per manufacturer's instructions; D.E. filters – backwash as per manufacturer's instructions; Cartridge filters – clean or replace cartridge.

TROUBLESHOOTING

ISSUE	CAUSE	CORRECTIVE ACTION
Low Flow (Cont)	Air leak in suction (bubbles issuing from return fittings).	Re-tighten using Teflon tape.
	Plugged, restricted, or damaged impeller.	Contact a qualified repair professional. Clear blockage and replace the impeller seal.
Noisy Pump	Air leak in suction piping, cavitation caused by restricted or undersized suction line or leak at any joint, low water level in pool, and unrestricted discharge return lines.	Correct suction condition or throttle return lines, if practical. Holding hand over return fitting will sometimes prove this point or putting in a smaller eyeball fitting.
	Vibration due to improper mounting, etc.	Mount the pump on a level surface and secure the pump to the equipment pad.
	Foreign matter in pump housing. Loose stones/debris hitting impeller could be cause.	Clean the pump housing.
	Squealing sounds that are getting louder over time	Bearings may become noisy over time if not properly maintained. They can be re-greased and should be done with regular pump maintenance, depending on usage. Check for leaks in the seals that may allow water, including chemicals, to work into the bearing ring and wipe out the grease. Any leaking seals should be replaced at once.
High Pressure Reading	Pipe blockage.	Check that all the pipe valves are in the open position.
	Pump blockage.	Check if there is any debris blocking inside of the pump.
	The filter cotton is hardened due to the excessive dirt inside the filter.	Run the pump in BACKWASH for 10 minutes..
Water Leakage (Filter Tank's Locking Ring Area)	Pipe blockage.	Check if the locking ring screws are tightened, and if there are any foreign objects inside the locking ring position.

TROUBLESHOOTING

ISSUE	CAUSE	CORRECTIVE ACTION
Water Leakage (Inlet, Outlet, and Drainage Port)	The damaged o-ring installed.	Adjust or replace the o-ring.
	The locking ring is not properly installed.	Tighten the screws of the locking ring to ensure proper installation.
Water Discharging (From The Drain- age Port During Filtration)	The sealing ring of the 4-way valve is damaged.	Replace with a new valve.

MAINTENANCE

PUMP MAINTENANCE

DANGER

Always ensure the power to the pump is disconnected before starting any work.

- Motors are designed to be self-lubricating, eliminating the need for additional lubrication.
- Check the motor for any blockage of air vents on the motor shell. If any debris is found, remove it after turning off the power source.
- If any leakage is noticed, inspect the shaft seals, and replace them if they show signs of wear.

Pump Protection

- Protection from heat:
 - Shield the motor from direct sunlight by providing shade.
 - Ensure any enclosure used is well-ventilated to prevent overheating.
 - Promote ample cross ventilation to keep the motor cool.
- Protection against dirt:
 - Safeguard the motor from any foreign matter or splashing water.
 - Avoid storing pool chemicals near the motor to prevent potential damage.
 - Refrain from sweeping or stirring up dust near the motor while it's in operation.
 - Remember that motor damage caused by dirt will void the motor warranty.
- Protection against moisture:
 - Shield the motor from splashing pool water and lawn sprinklers.
 - Keep it protected from harsh weather conditions.
 - If the motor gets wet, allow it to dry completely before operating it again. Avoid using the pump if it has been flooded.
 - Note that water damage to the motor will void the motor warranty.

CAUTION

Never wrap the motor with plastic or any other airtight materials. While it's acceptable to cover the motor during a storm or for winter storage, it should never be covered while it is operating or expected to be in operation.

NOTE

When replacing the motor, ensure that the motor support is correctly positioned to adequately support the size of the motor being installed.

MAINTENANCE

WATER CHEMISTRY

Maintaining proper water chemistry is essential for clean, sanitary water and to control algae growth in the pool or spa.

Chlorine

Use dry or liquid chlorine (calcium or sodium hypochlorite) daily to ensure clean and sanitary water. Chlorine dissipates due to dirt, germs, sunlight, and wind exposure.

pH Level

Maintain the correct level of acidity or alkalinity in the pool water.

Desirable range: 7.2 - 7.4

Figure Z

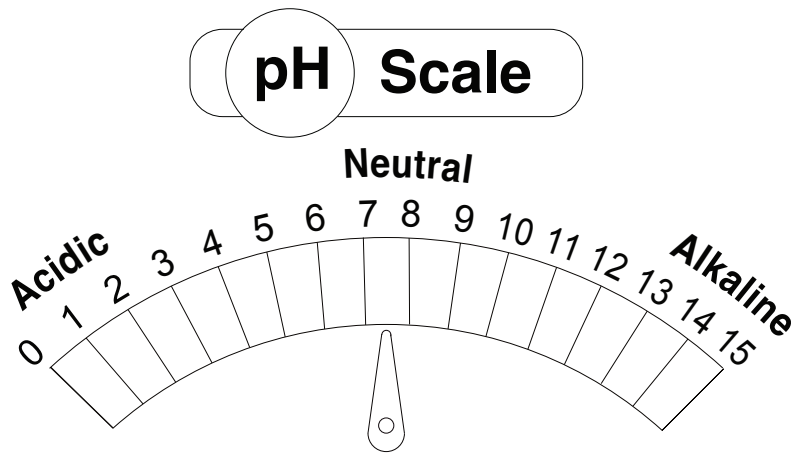

REPLACEMENT PARTS

REPLACEMENT PARTS

PARTS DIAGRAM

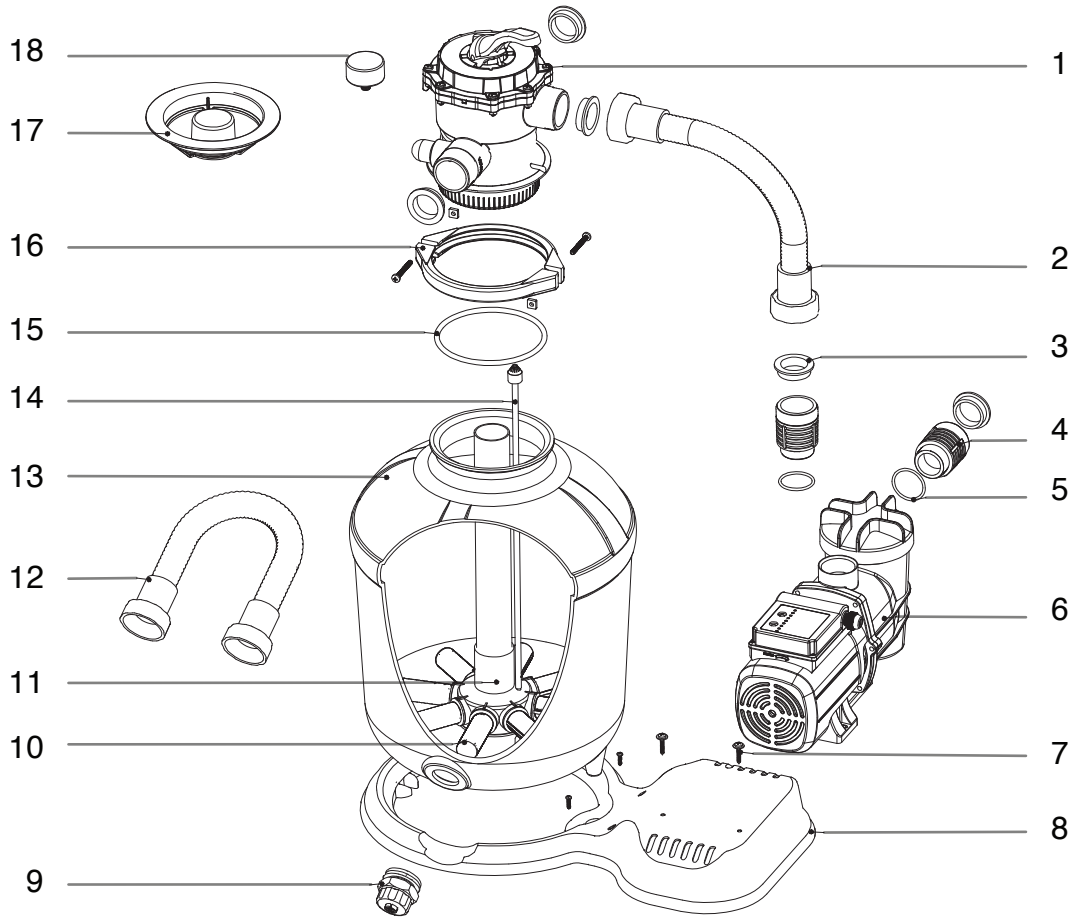

ITEM	PARTS NO.	DESCRIPTION	QTY
1	647303971000	7-WAYS VALVE	1
2	647229006001	1 1/2" X 15 1/8" HOSE	1
3	65432055080	GASKET $\Phi 56 * \Phi 47 * 14$	5
4	647279510	CONNECTOR	2
5	5431021080	O-RING $\Phi 44.04 X \Phi 3.53$	2
6	72722000	PUMP	1
7	65862072000	SCREWS 2 * ST5.5 X 30 AND GASKET 2 * $\Phi 16 X \Phi 6.5 X 1$	2
8	47279502080	SAND FILTER SUPPORT	1
	47279503080	PUMP SUPPORT	1
	5212008000	SCREW	2

ITEM	PARTS NO.	DESCRIPTION	QTY
9	647304073000	DRAIN PLUG	1
10	647304017080	LATERALS	8
11	647304571000	CENTRAL PIPE	1
12	647229003001	1 1/2" HOSE 5.4'	2
13	647303901	16" FILTER TANK	1
14	647304172000	AIR RELEASE ASSEMBLY	1
15	65431041080	O-RING $\Phi 145.42 X \Phi 6.99$	1
16	647303076000	FLANGE CLAMP W/ SCREW & NUT	1
17	647303016080	NECK FITTING	1
18	97202	PRESSURE GAUGE	1

DISCLAIMER

DISCLAIMER

PLEASE READ THE FOLLOWING CAREFULLY

The manufacturer and/or distributor have provided the parts list and assembly diagram in this manual for reference purposes only. They do not make any representation or warranty to the buyer that they are qualified to make repairs to the product or replace any parts of the product. In fact, the manufacturer and/or distributor expressly state that all repairs and parts replacements should be undertaken by certified and licensed technicians, and not by the buyer.

The buyer assumes all risk and liability arising from their repairs to the original product or replacement parts or arising from their installation of replacement parts. It is strongly advised that qualified professionals handle any repairs or replacements to ensure safety and proper functioning of the product. Improper installation and operation may result in injury, property damage, or voiding of warranty. The manufacturer and/or distributor shall not be held responsible for any accidents, damages, or malfunctions resulting from the buyer's installation and operation of the product. It is essential to follow all safety guidelines and recommendations provided in this manual and to seek professional assistance if unsure about the installation or operation procedures.

CUSTOMER SERVICE

If you have any questions about ordering our pool pumps and replacement parts or pool products, please feel free to contact us using the following contact information:

Customer Service and Technical Support

Phone: (909) 628-0880

Email: customer@xtremepowerusa.com

Hours of Operation: Monday – Friday, 9AM – 4PM (CST)
