

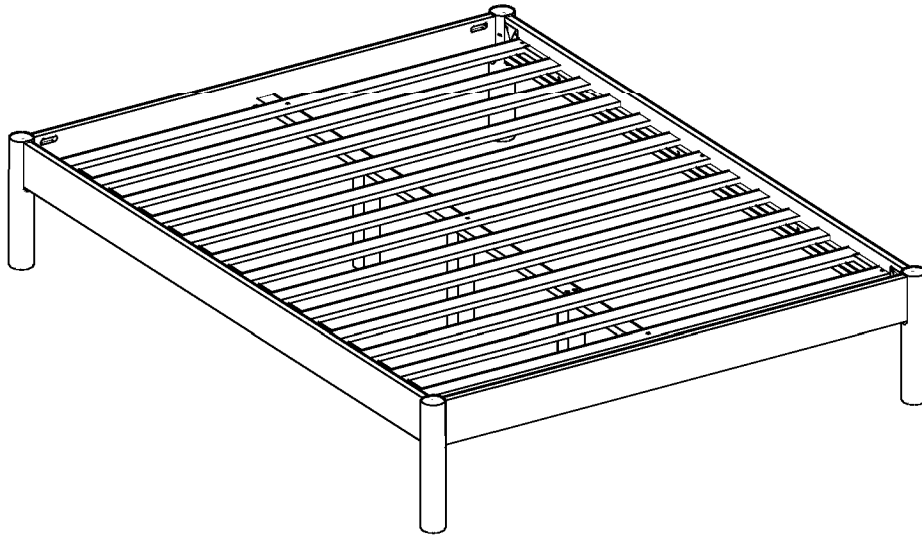







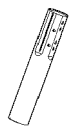

# ASSEMBLY INSTRUCTIONS

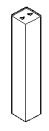
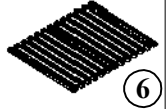

## COMPONENT

<p>Headboard/ Footboard - 2 pcs.</p>  <p>①</p>	<p>Leg (Left) - 2 pcs.</p>  <p>②L</p>	<p>Leg (Right) - 2 pcs.</p>  <p>②R</p>	<p>Side Rail - 2 pcs.</p>  <p>③</p>	<p>Center Rail - 1 pc.</p>  <p>④</p>	<p>Center Leg - 3 pcs.</p>  <p>⑤</p>	<p>Slats - 13 pcs.(1set)</p>  <p>⑥</p>
---	---	--	---	--	--	--

## HARDWARE

<p>Allen Key M4 (Long Ball Head) - 1 pc.</p>  <p>Ⓐ</p>	<p>JCBC Bolt M6 x 40mm - 14 pcs.</p>  <p>Ⓑ</p>	<p>M6 Spring Washer - 8 pcs.</p>  <p>Ⓒ</p>	<p>Wood Dowel M8 x 30mm - 8 pcs.</p>  <p>Ⓓ</p>	<p>Wood Screw M3.5 x 16mm - 2 pcs.</p>  <p>Ⓔ</p>	<p>Wood Screw M4 x 25mm - 9 pcs.</p>  <p>Ⓕ</p>
--	---	---	---	---	---

# ASSEMBLY INSTRUCTIONS

## STEP 1 :

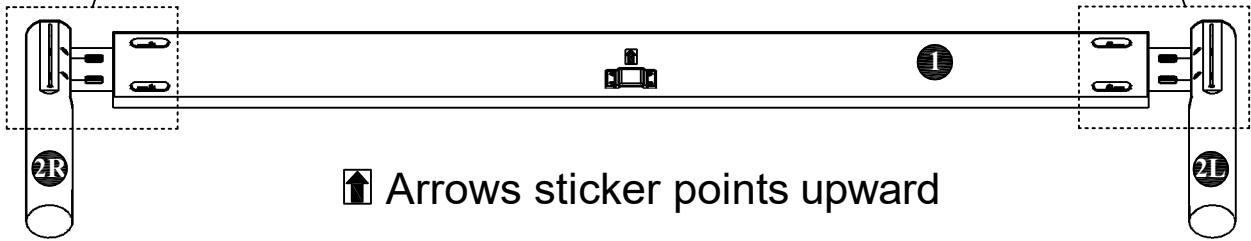
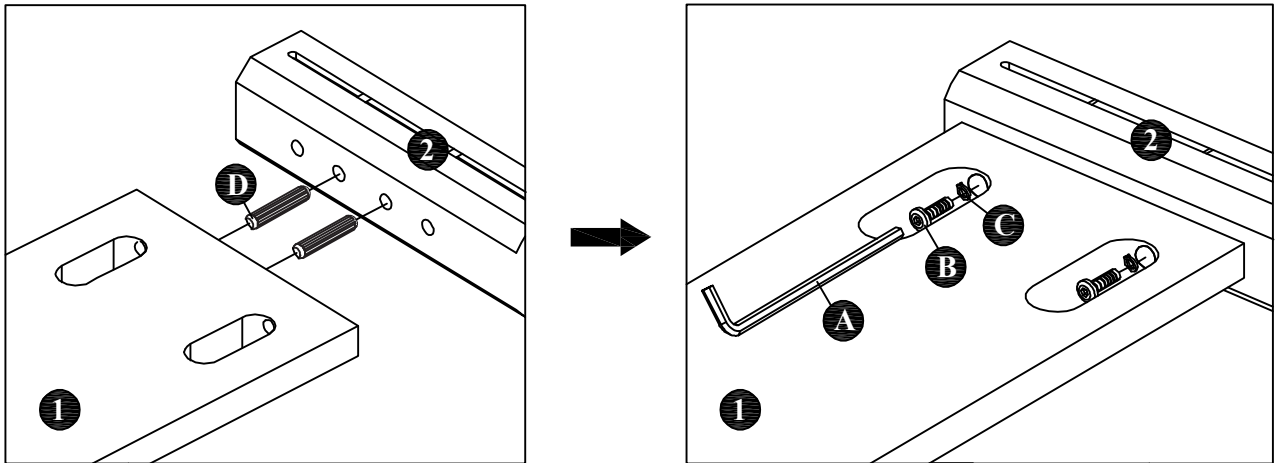

## STEP 2 :

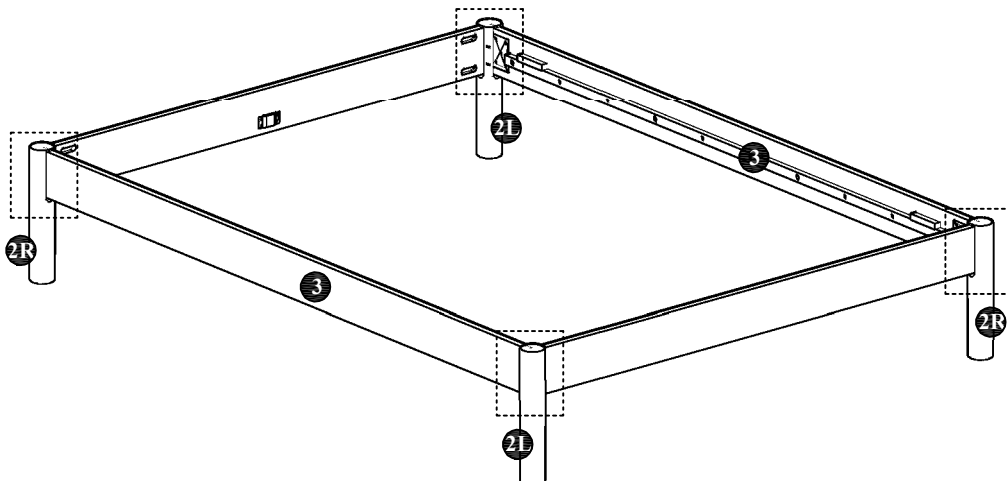
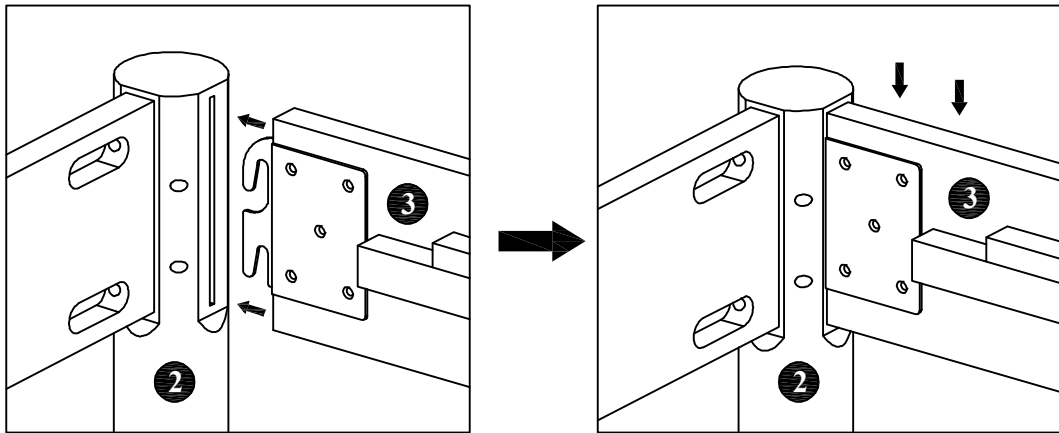

# ASSEMBLY INSTRUCTIONS

STEP 3 :

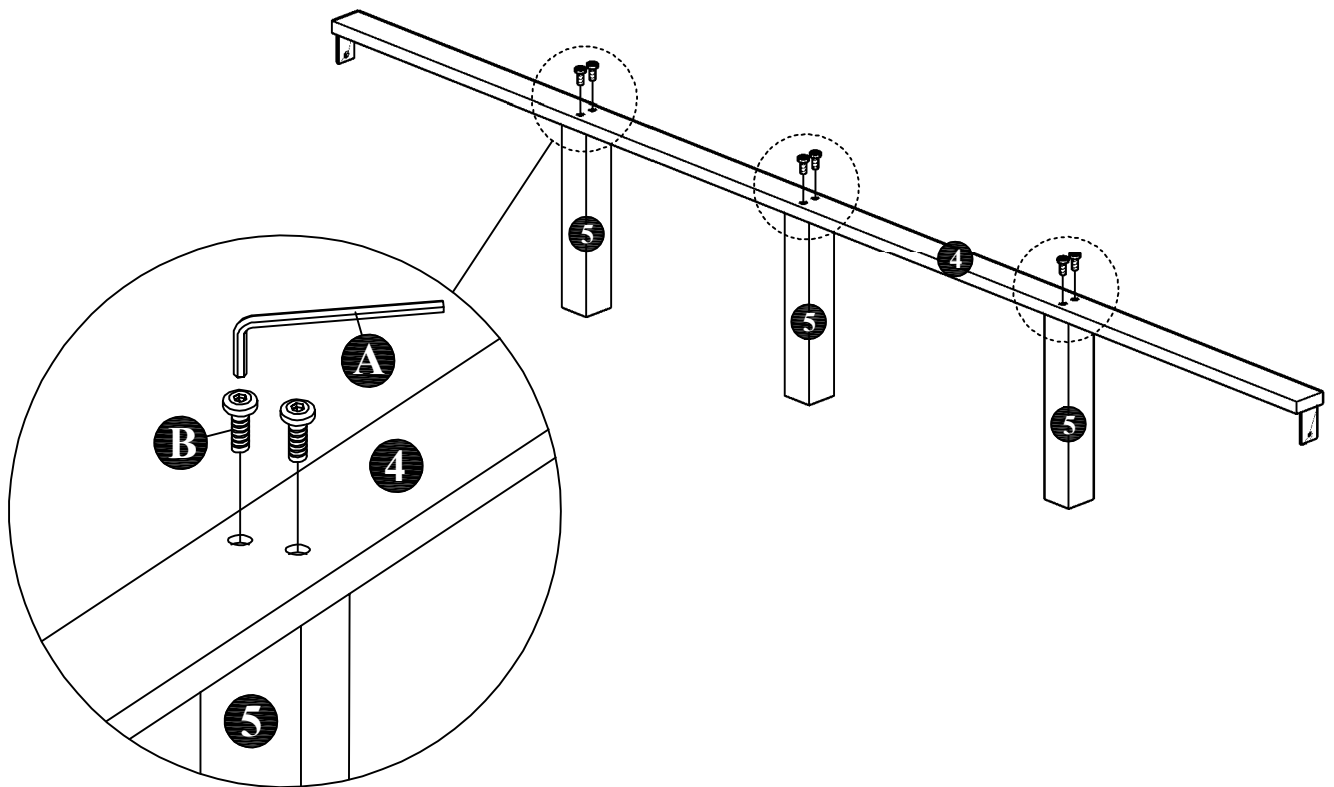

STEP 4 :

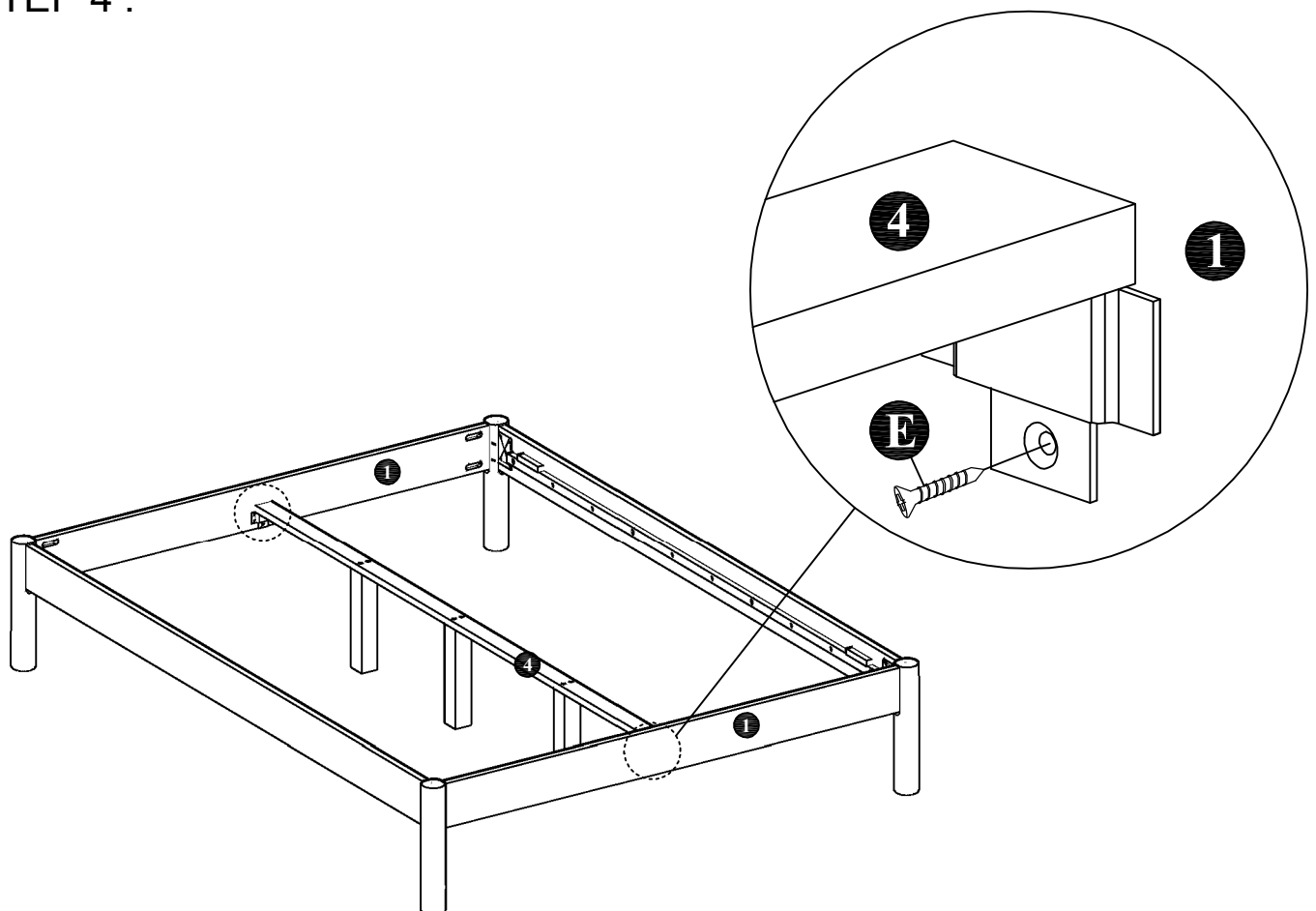

# ASSEMBLY INSTRUCTIONS

STEP 5 :

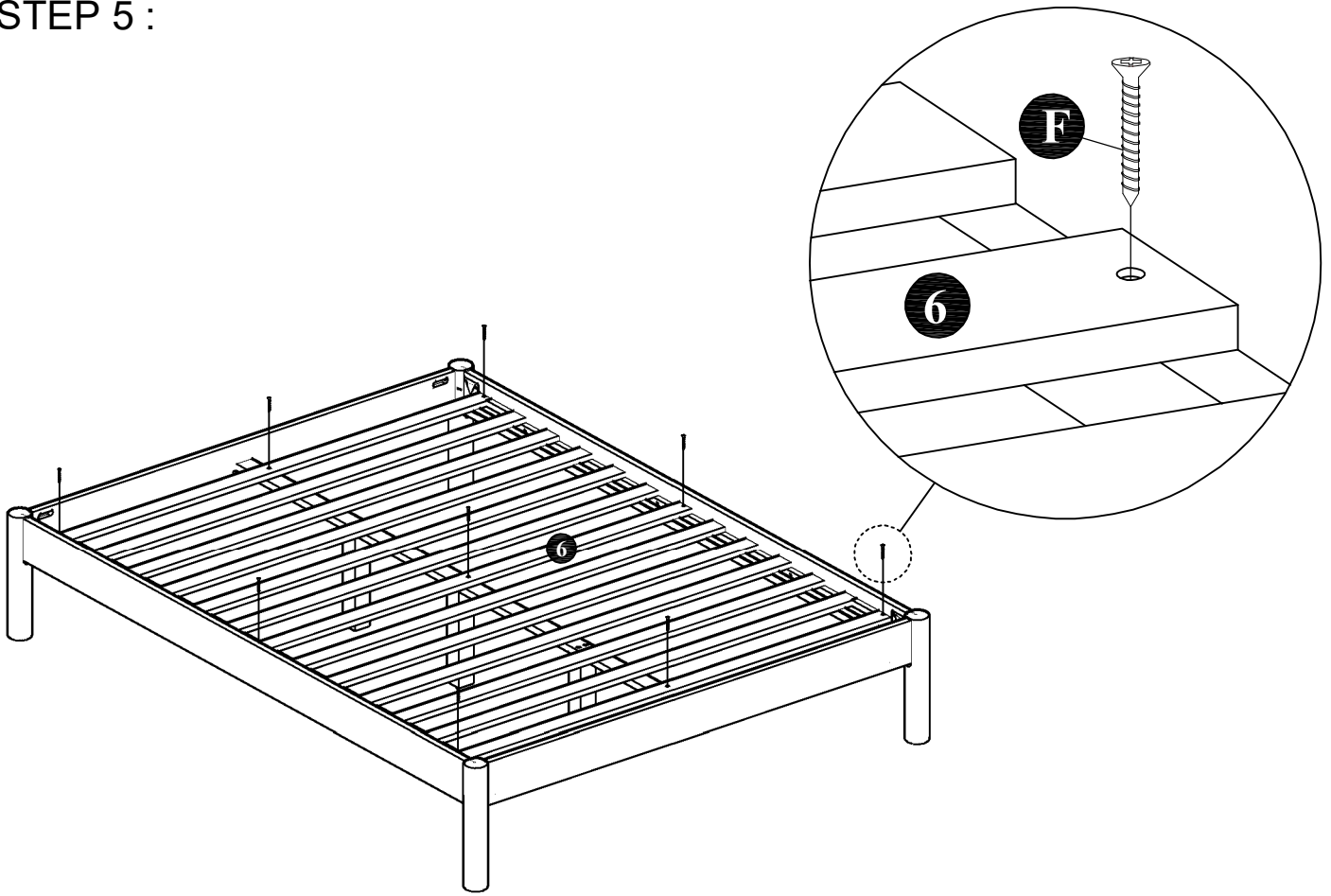

## COMPLETE VIEW

**\*IMPORTANT\***

Please lift up the bed to move  
with 2 or more people.

**DO NOT DRAG THE BED!**

