

# NOTICE

\* Please make sure that you have all parts indicated and they are in good condition before you begin assembly of this item. Refer to part list and hardware list below for guidance.

\* This item should be assembled on a soft surface to prevent scratching the finish during assembly.

\* This item may require periodic tightening.

## PREPARATION

\* Before beginning assembly of product, make sure all parts are present. Compare parts with part contents list and hardware contents list.

\* If any part is missing or damaged, do not attempt to assemble the product













\* Estimated assembly time : **30 minutes.**

\* Tools required for assembly (included) : **Allen key**

## CARE AND MAINTENANCE

Always use felt pads under all articles to prevent discoloration or softening of the lacquer. Plastic and rubber bases on items can discolor wood. Wipe up spill immediately and avoid common hazards such as hot dishes, harsh solvents and abrasives. Cleaning should be done with a soft lint free cotton cloth dampened with water or furniture polish.

### Part List and Hardware List

PIECE	DESCRIPTION	PICTURE	QUANTITY
A	Seat Frame		1x
B	Leg Frame		2x
C	Stretcher (Short)		2x
D	Stretcher (Long)		2x
E	Plate Panel		1x
HW 1	Jcbc Bolt M6x0.5x20mm		8x
HW 2	Flat Washer		8x
HW 3	Spring Washer		8x
HW 4	Swivel Plate		1x
HW 5	JcbcW Bolt M7x3.0x40mm		12x
HW 6	Allen key (Long)		1x
HW 7	Wood Button		8x

Product Dimensions : 20.66" W x 17.12" D x 34.25" H

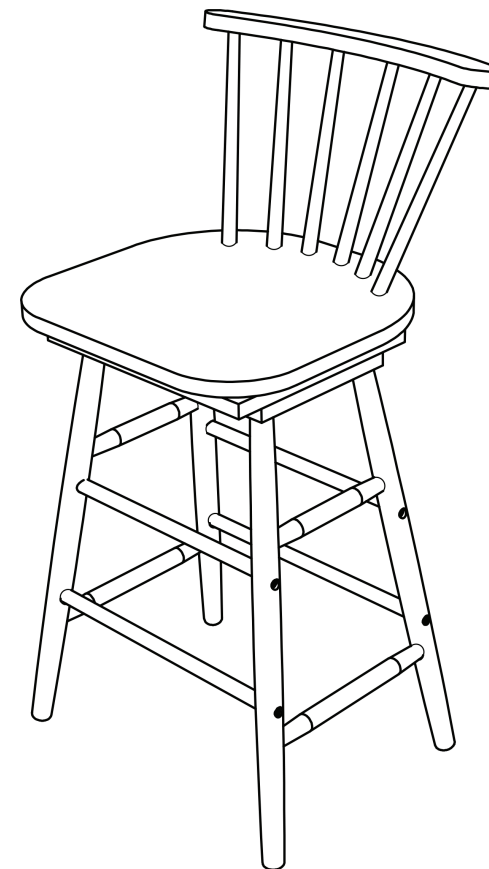

Weight capacity - 236 LBS

Warning : Do not stand on chair.

Warning : Do not over torque bolts.

## PREPARATION

- \* Before beginning assembly of product, make sure all parts are present. Compare parts with part contents list and hardware contents list.
- \* If any part is missing or damaged, do not attempt to assemble the product.
- \* Estimated assembly time : 30 minutes
- \* Tools required for assembly (included) : Allen key

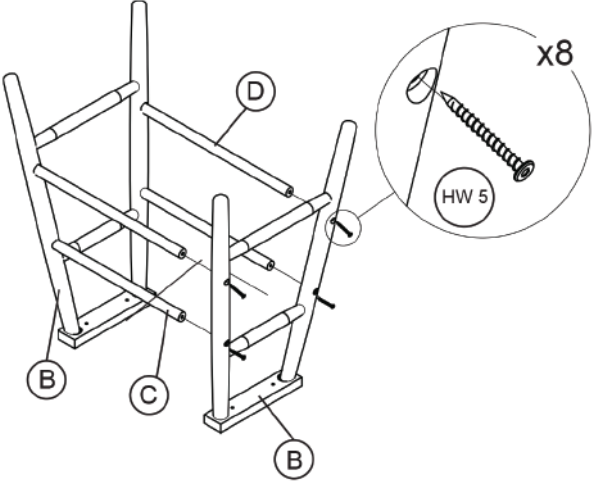
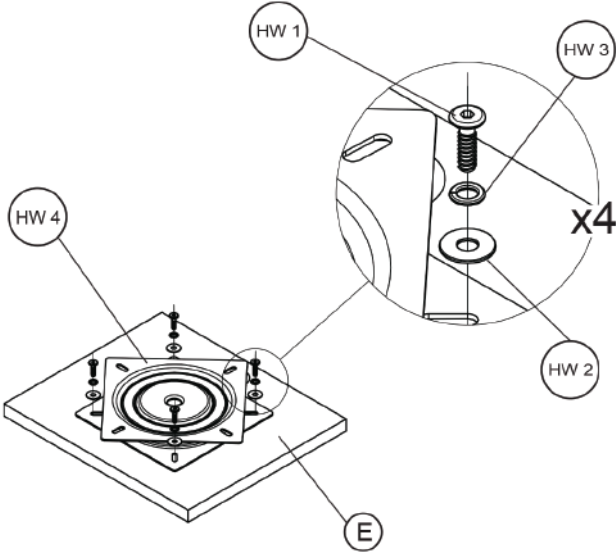
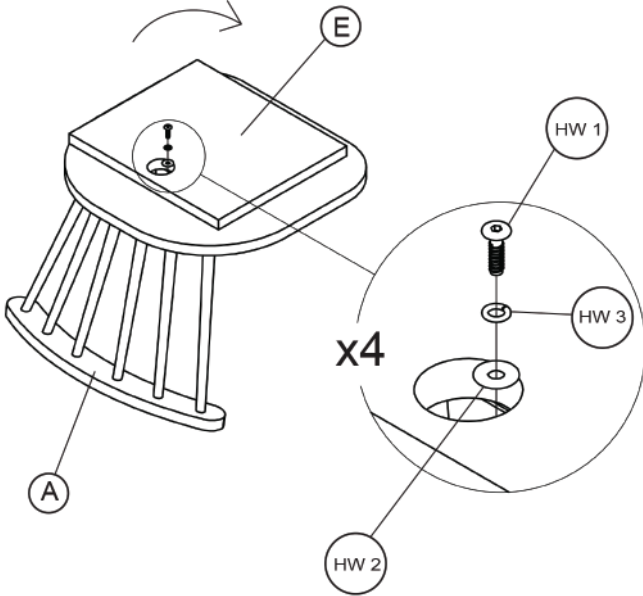
		
<p><b>Step 1</b> : Screw both left and right leg to the stretchers (long and short).</p>	<p><b>Step 2</b> : Place the swivel plate to the plate panel and tighten it with the bolts.</p>	<p><b>Step 3</b> : Screw the pre-assembled plate panel (step 2) with the seat frame. Turn around the plate panel to position the screw into places.</p>

## PREPARATION

- \* Before beginning assembly of product, make sure all parts are present. Compare parts with part contents list and hardware contents list.
- \* If any part is missing or damaged, do not attempt to assemble the product.
- \* Estimated assembly time : 30 minutes
- \* Tools required for assembly (included) : Allen key

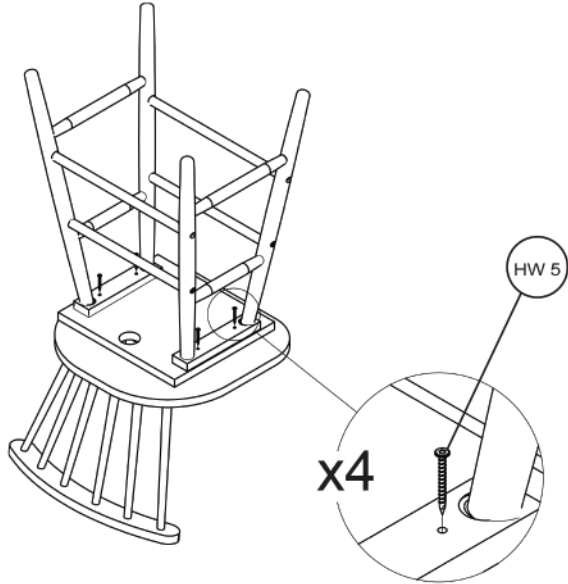
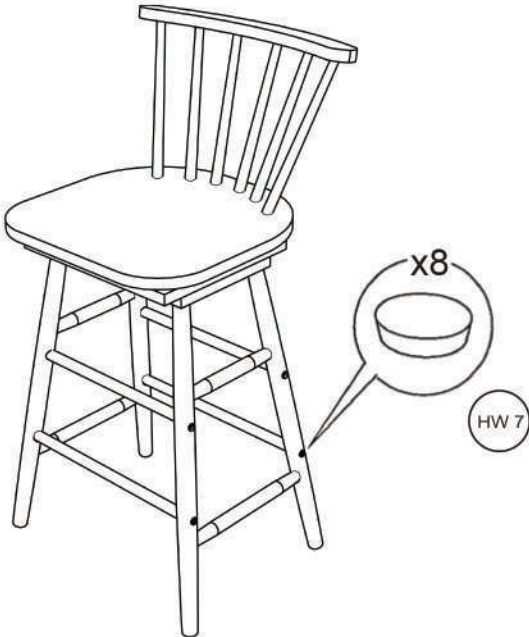
 <p>The diagram shows a partial chair frame with the seat and backrest. A leg assembly is being attached to the seat frame. A circular callout shows a close-up of a screw being inserted into a hole in the wood. The callout is labeled 'x4' and 'HW 5'.</p>	 <p>The diagram shows the chair upright. A circular callout shows a wood button being placed over a screw hole on the leg. The callout is labeled 'x8' and 'HW 7'.</p>
<p><b>Step 4 :</b> Place the assembled leg (step 1) to the seat frame (step 3). Screw it with the bolts.</p>	<p><b>Step 5 :</b> Upright the chair and place the wood button to cover the screw hole.</p>