

Toilet Paper Holder (LH) Installation Guide

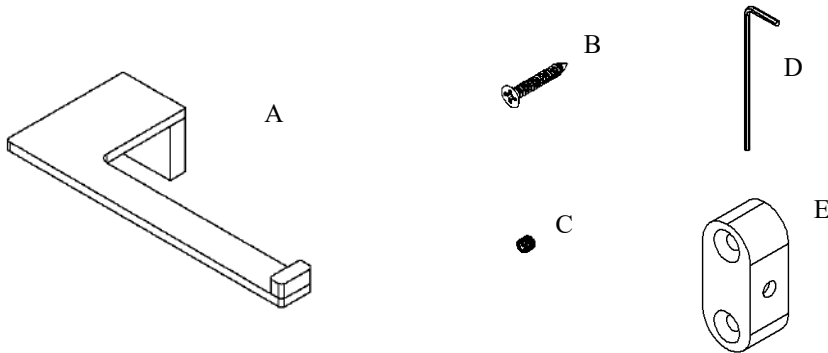

Parts Included	QTY
A - Toilet Paper Holder (LH)	1
B - Screw	2
C - Set Screw	1
D - Allen Key	1
E - Bracket	1

Description	Finish	Weight (lb)	WxHxD (mm)	WxHxD (Inches)	Metal Type
Toilet Paper Holder (LH)	Chrome	0.64	176 x 43 x 75	7 x 2 x 3	Brass
Toilet Paper Holder (LH)	Brushed Nickel	0.64	176 x 43 x 75	7 x 2 x 3	Brass
Toilet Paper Holder (LH)	Matte Black	0.64	176 x 43 x 75	7 x 2 x 3	Brass

Warranty: 2 Years

Care & Maintenance: A periodic wash using warm water and a soft cloth will retain the high quality finish of your product for many years to come. ON NO ACCOUNT should any household bleaches, detergents, abrasive polishes, steel wool or other cleaning agents be used on this item.

