

Assembly Instructions

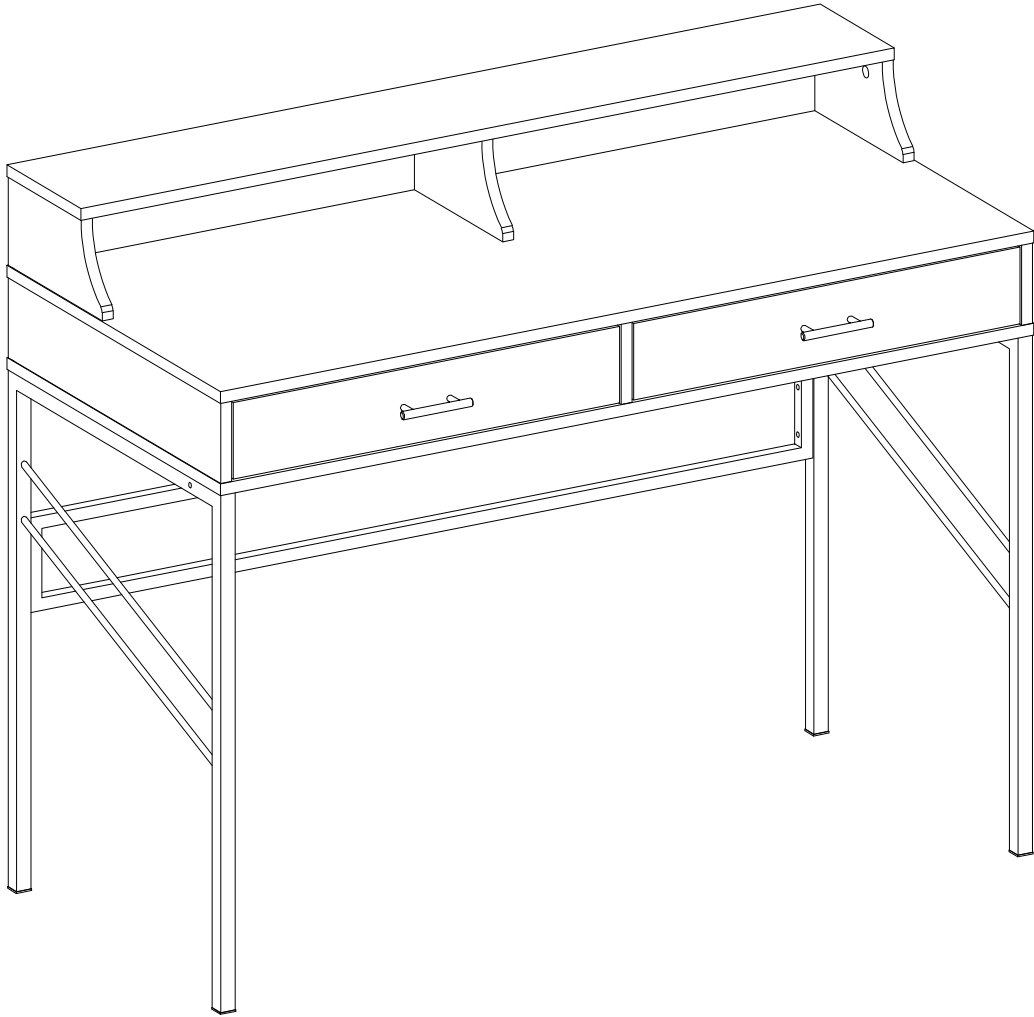

General Assembly Guidelines

- I. Ensure that all parts and hardware are available before beginning assembly.
- II. Follow each step carefully to ensure the proper assembly of this product.
- III. Two people are recommended for ease in the assembly of this product.
- IV. The three main types of hardware used to assemble this product are: wood dowels, screws and bolts.
- V. The provided glue is to secure wood dowels in place. When first inserting dowels, locate the appropriate hole for the dowel, place a small amount of glue in the hole and insert the dowel. Wipe away excess glue immediately.

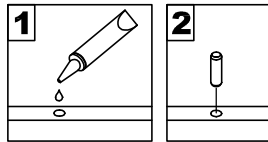

In future assembly steps when dowels are necessary to attach assembly parts together, place a small amount of glue on the end of the dowel before attaching parts together. Wipe away excess glue immediately.

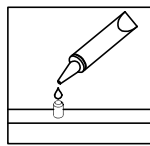

- VI. A Phillips head screwdriver is required for the assembly of this product .

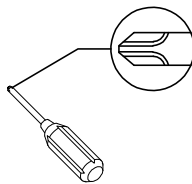

- VII. Power tools should not be used to assemble this product.

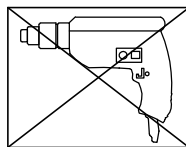





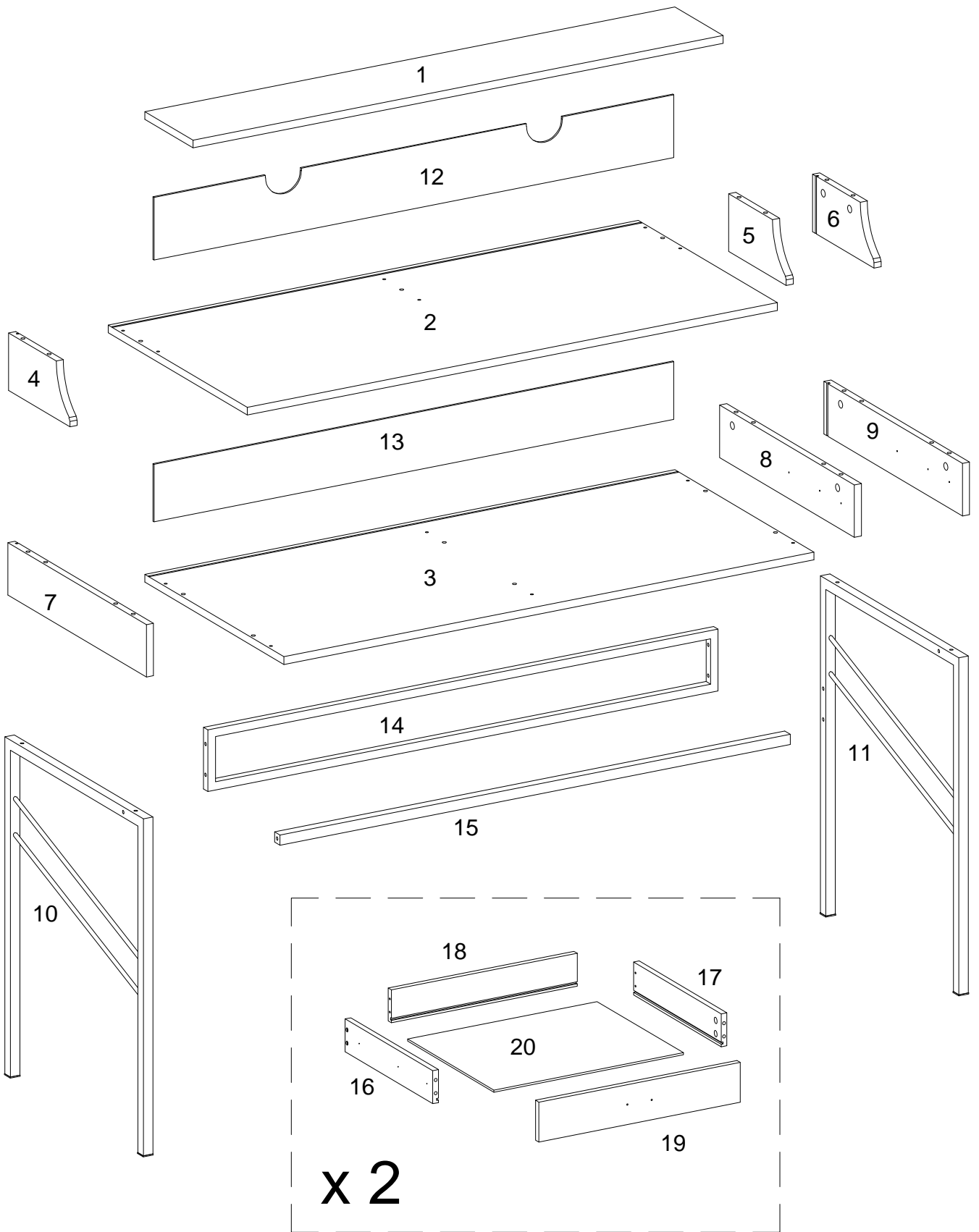





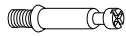

- VIII. Drill may be needed for securing product to wall.

Parts List

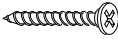

Hardware List

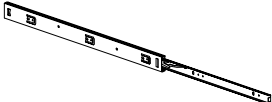
A		Ø8x30mm	Wooden dowel	15 pcs
B		Ø15x11mm	Cam lock	20 pcs
C		Ø6x35mm	Cam bolt	20 pcs
D		Ø30mm	Sticker	20 pcs
E		Ø6x35mm	Screw	2 pcs
F		Ø6x30mm	Screw	8 pcs
G		M4mm	Hex Key	1 pc
H			Plastic wedge	12 pcs
J		Ø3x17mm	Screw	12 pcs
K		Ø4x38mm	Screw	20 pcs
L			Glue tube	1 pc
M		Ø3x12mm	Screw	24 pcs
N			Handle	2 pcs
P		Ø4x22mm	Bolt	4 pcs
Q			Drawer slider	2 sets

* Note: This piece comes preassembled for shipping purposes and must be disassembled to complete the desk assembly.

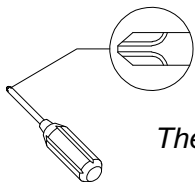

Philips head screwdriver required for assembly
(not included)

*The hardware quantities listed above are required for proper assembly.
Some extra hardware may also have been included.*

Step 1

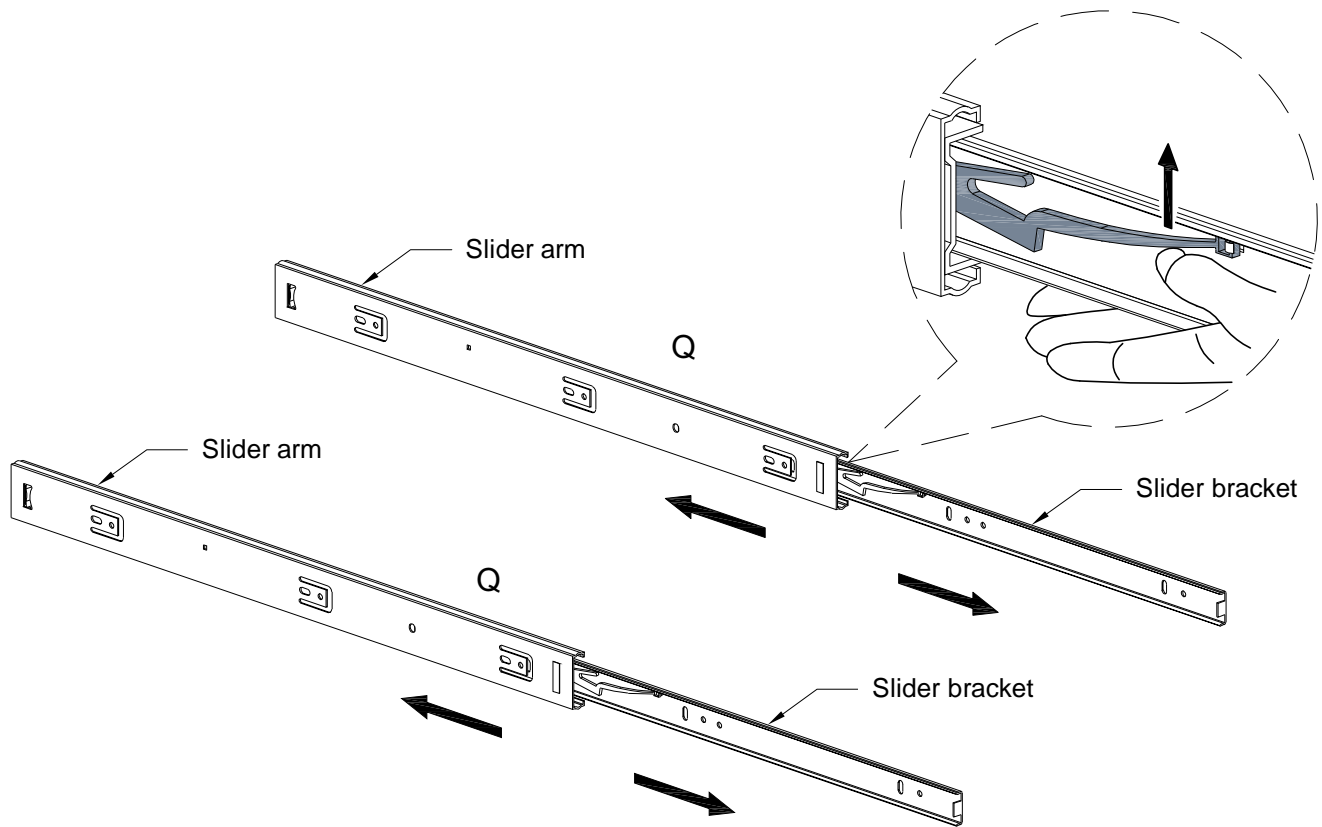

Pick up the slider arm (Q) and separate the slide runner for the following Steps. Extend the slide runner all the way forward, press the plastic release lever of the slider arm up and pull the slide runner complete out .

Step 2

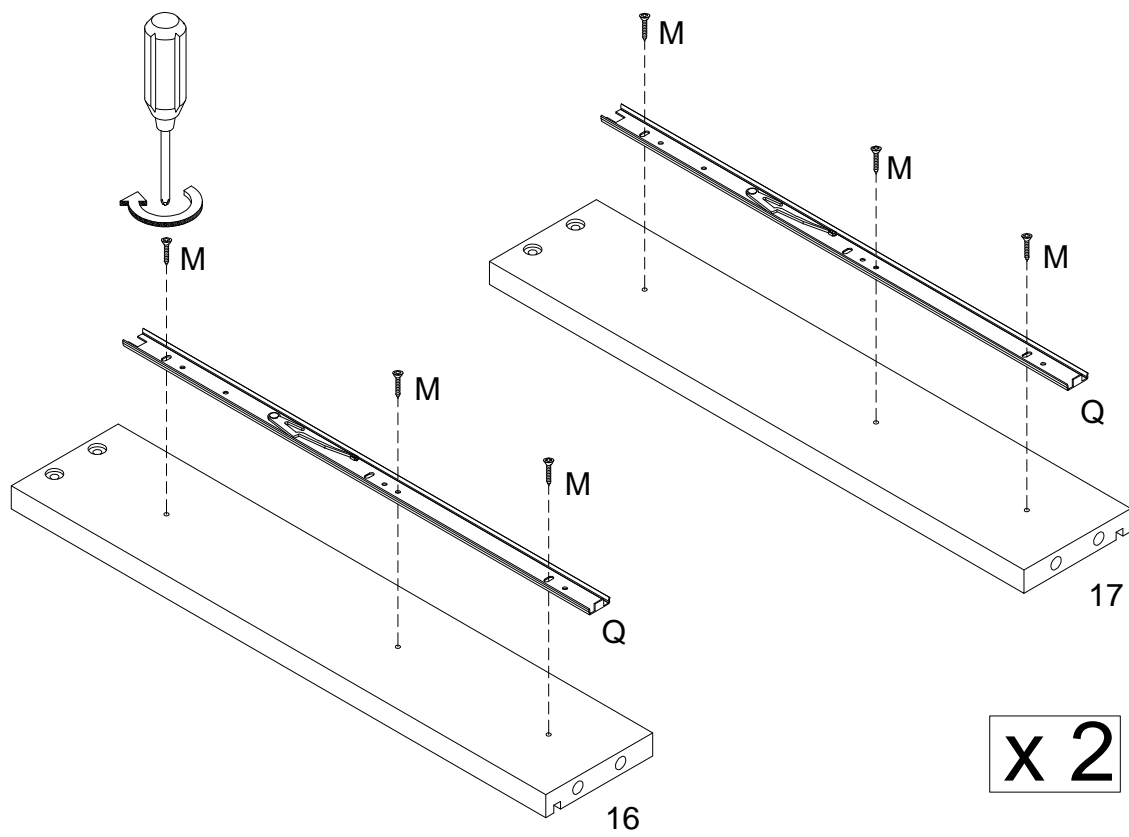

Using screw (M) attach drawer slider (Q) to parts (16,17) with Philips head screwdriver as per diagram.

Step 3

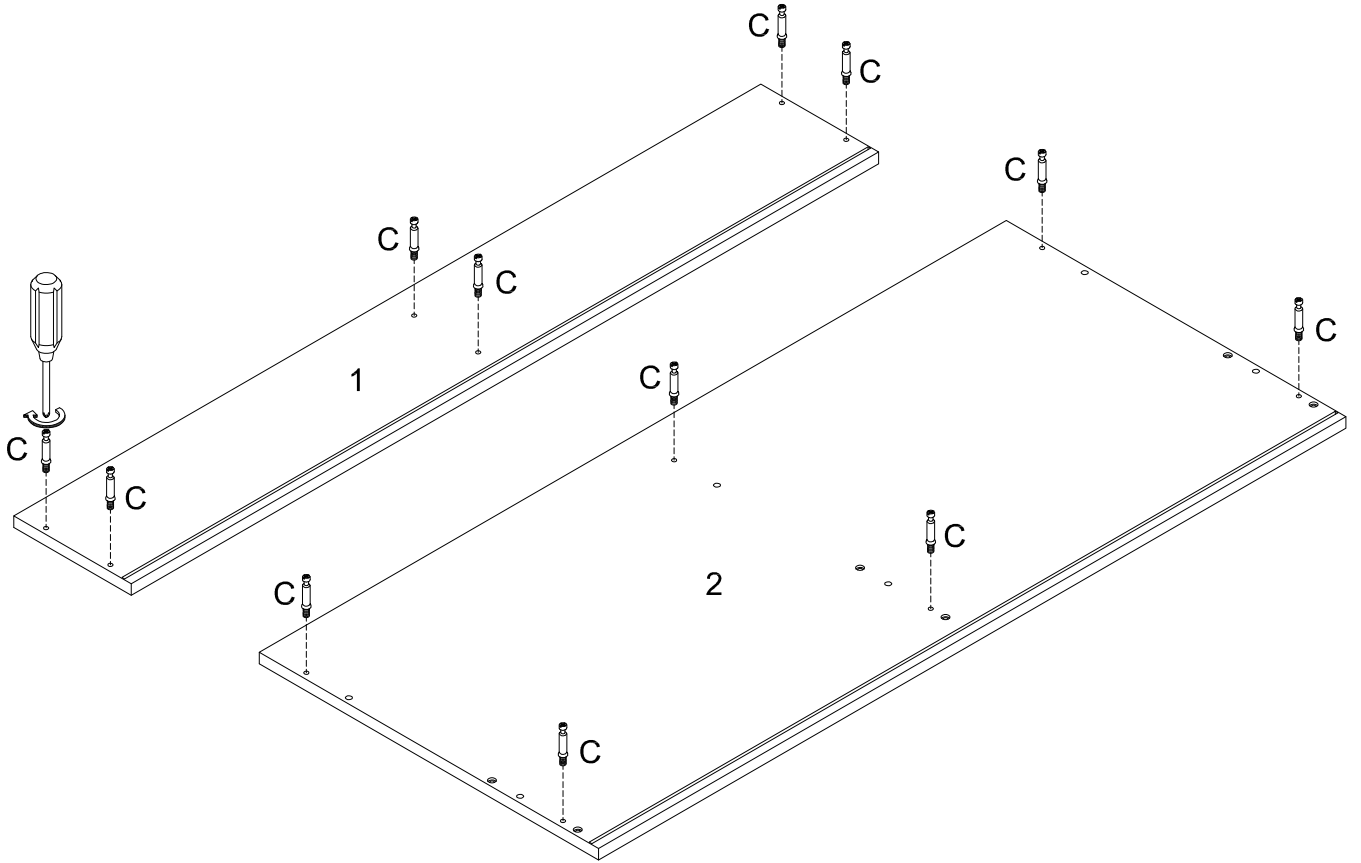

Secure cam bolt (C) into parts (1,2) with Philips head screwdriver as per diagram.

Step 4

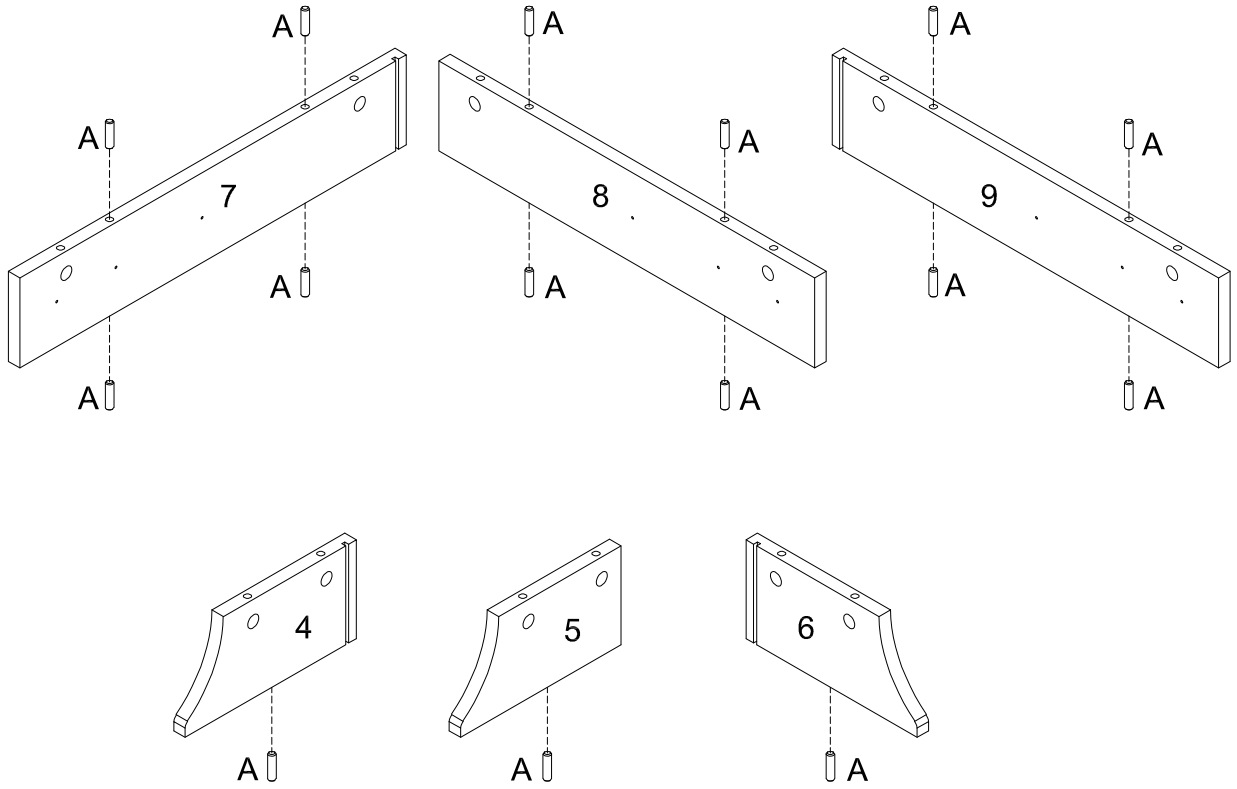

Insert wooden dowel (A) into parts (4,5,6,7,8,9) as per diagram.

Step 5

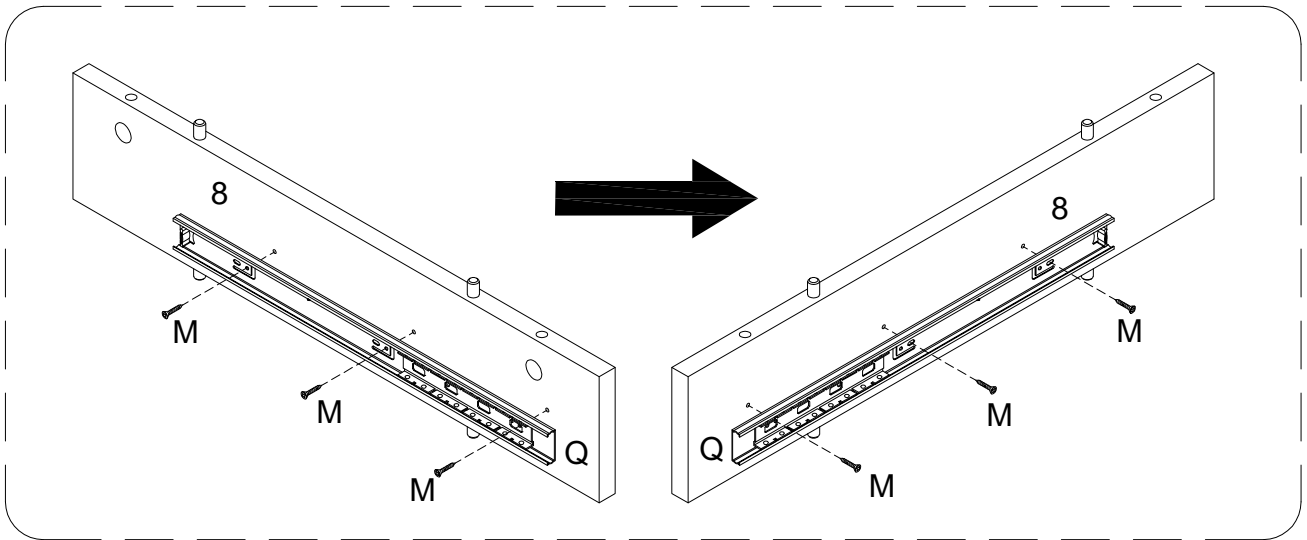
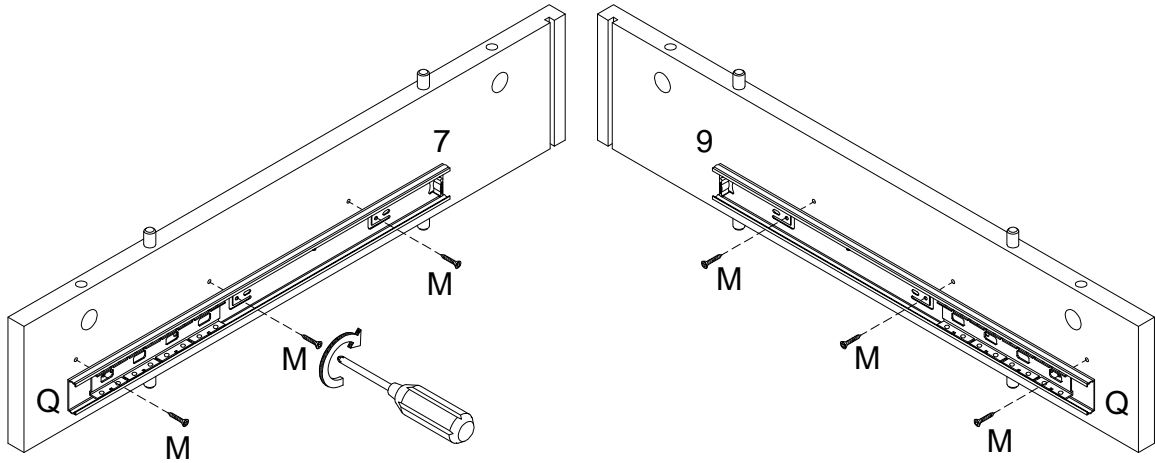

Using screw (M) attach drawer slider (Q) to parts (7,8,9) with Philips head screwdriver as per diagram.

Step 6

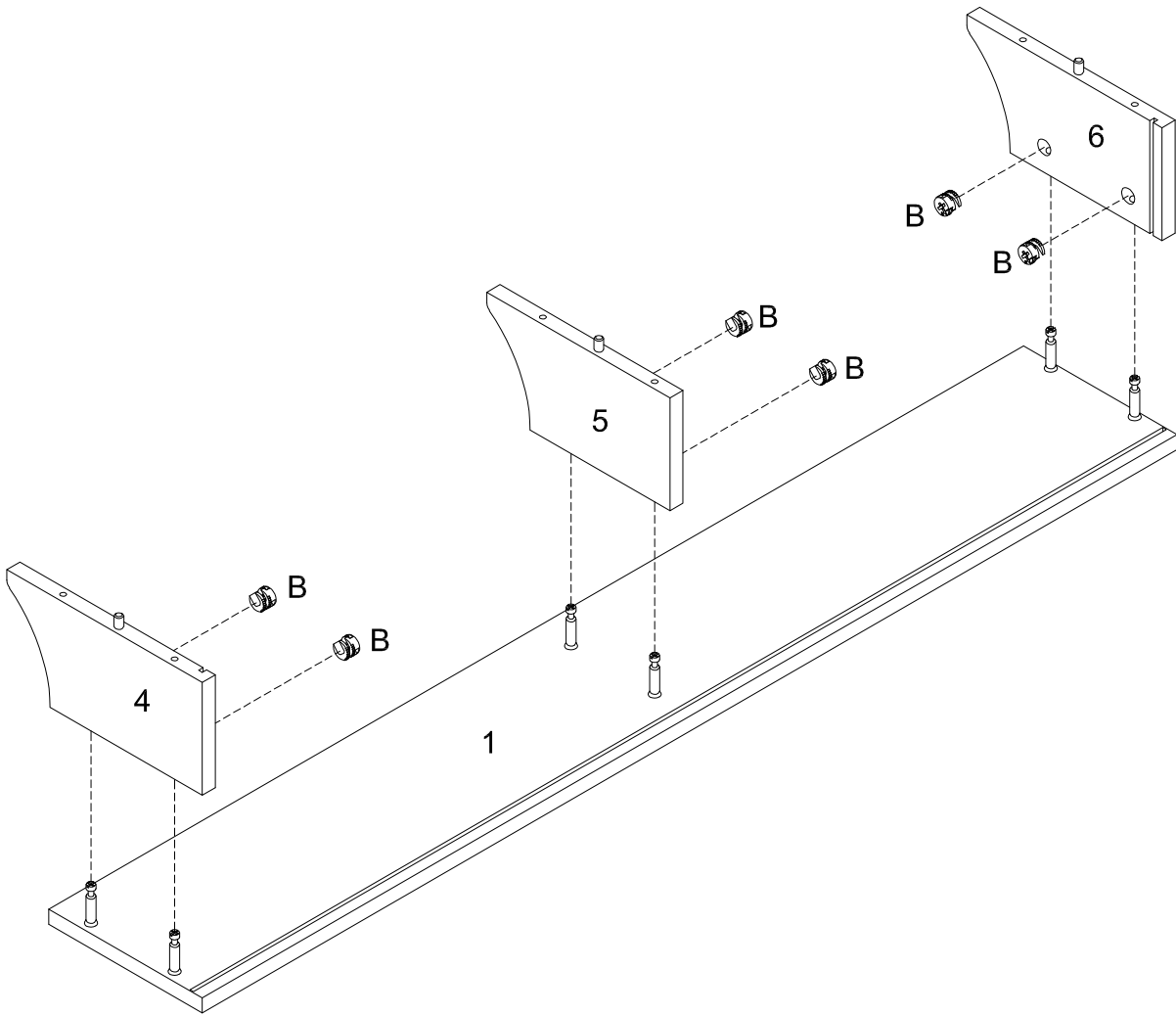
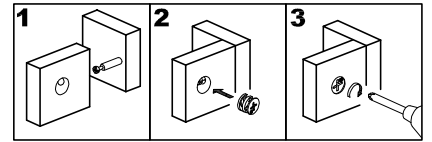

Using Cam lock (B) secure parts (4,5,6) to part (1) with Philips head screwdriver as per diagram.

Step 7

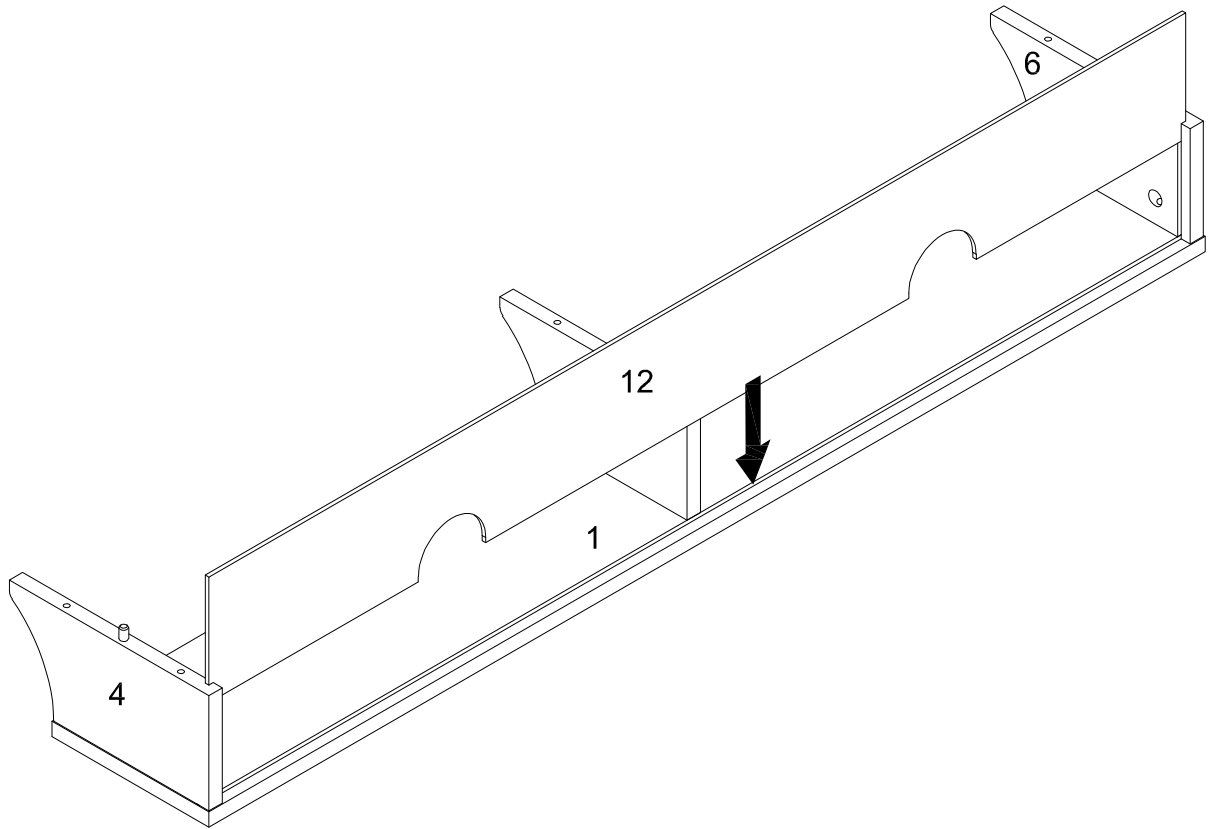

Put part (12) as per diagram.

Step 8

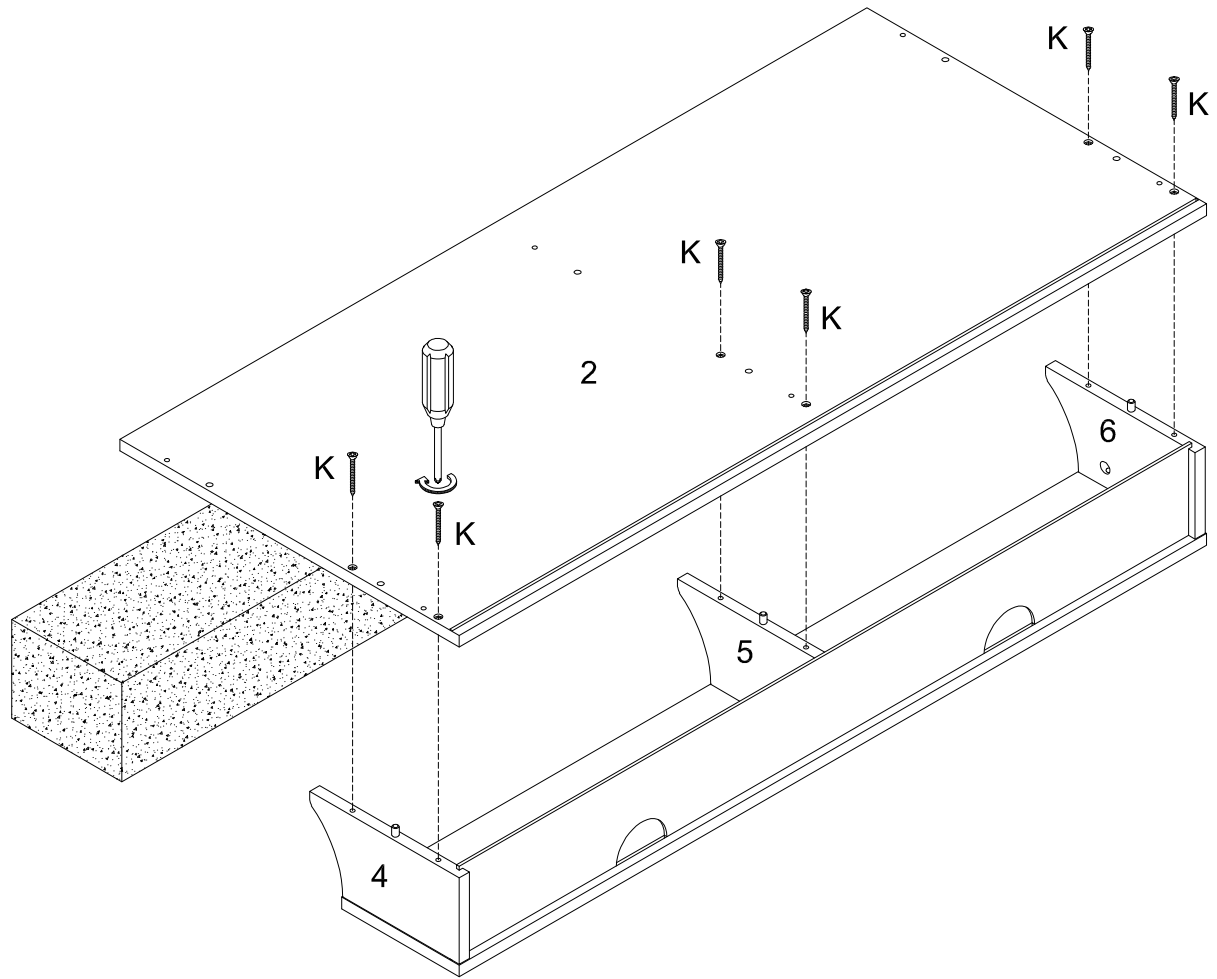

Using screw (K) attach part (2) to parts (4,5,6) with Philips head screwdriver as per diagram.

Step 9

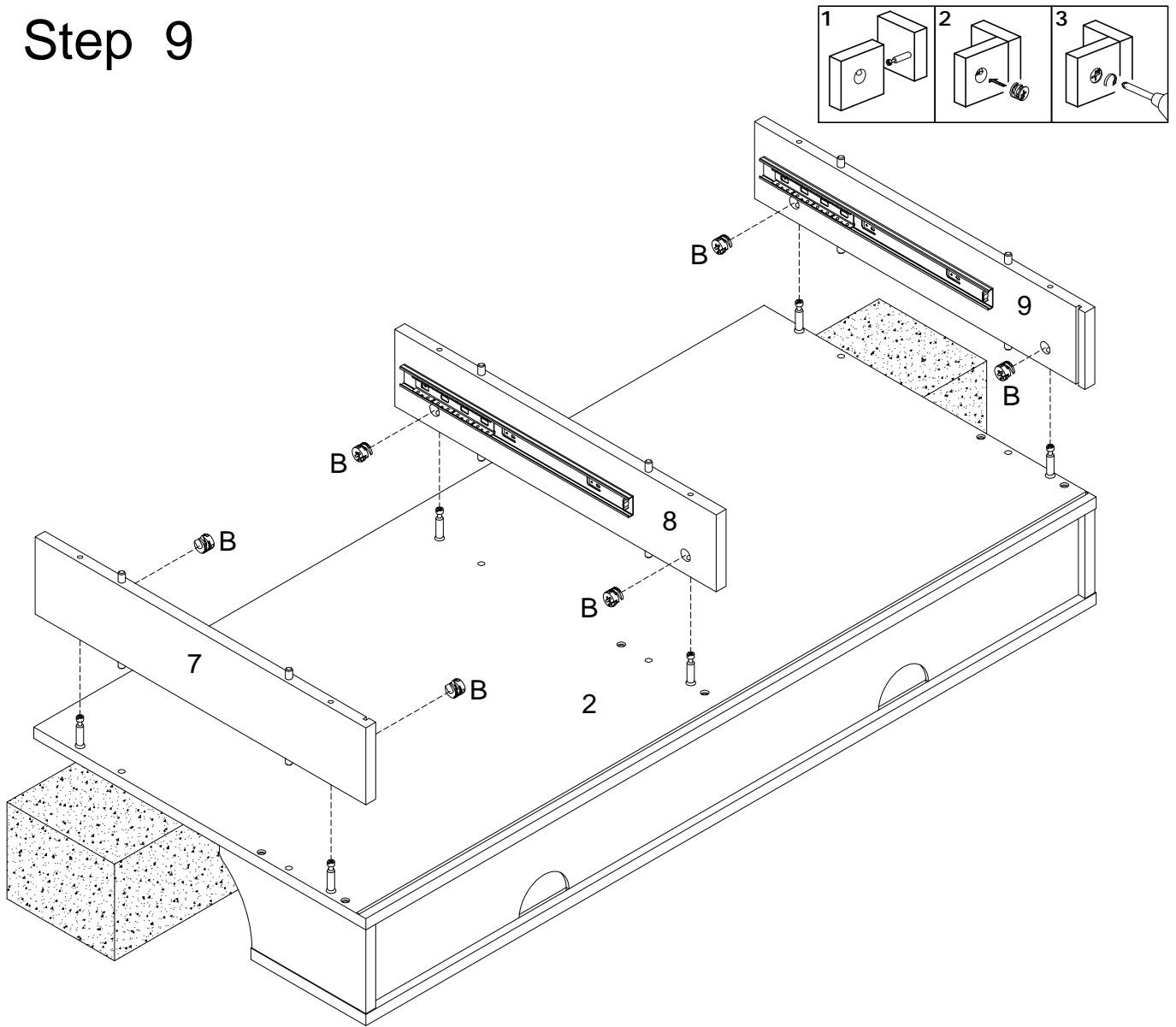

Using Cam lock(B) secure parts (7,8,9) to part (2) with Philips head screwdriver as per diagram.

Step 10

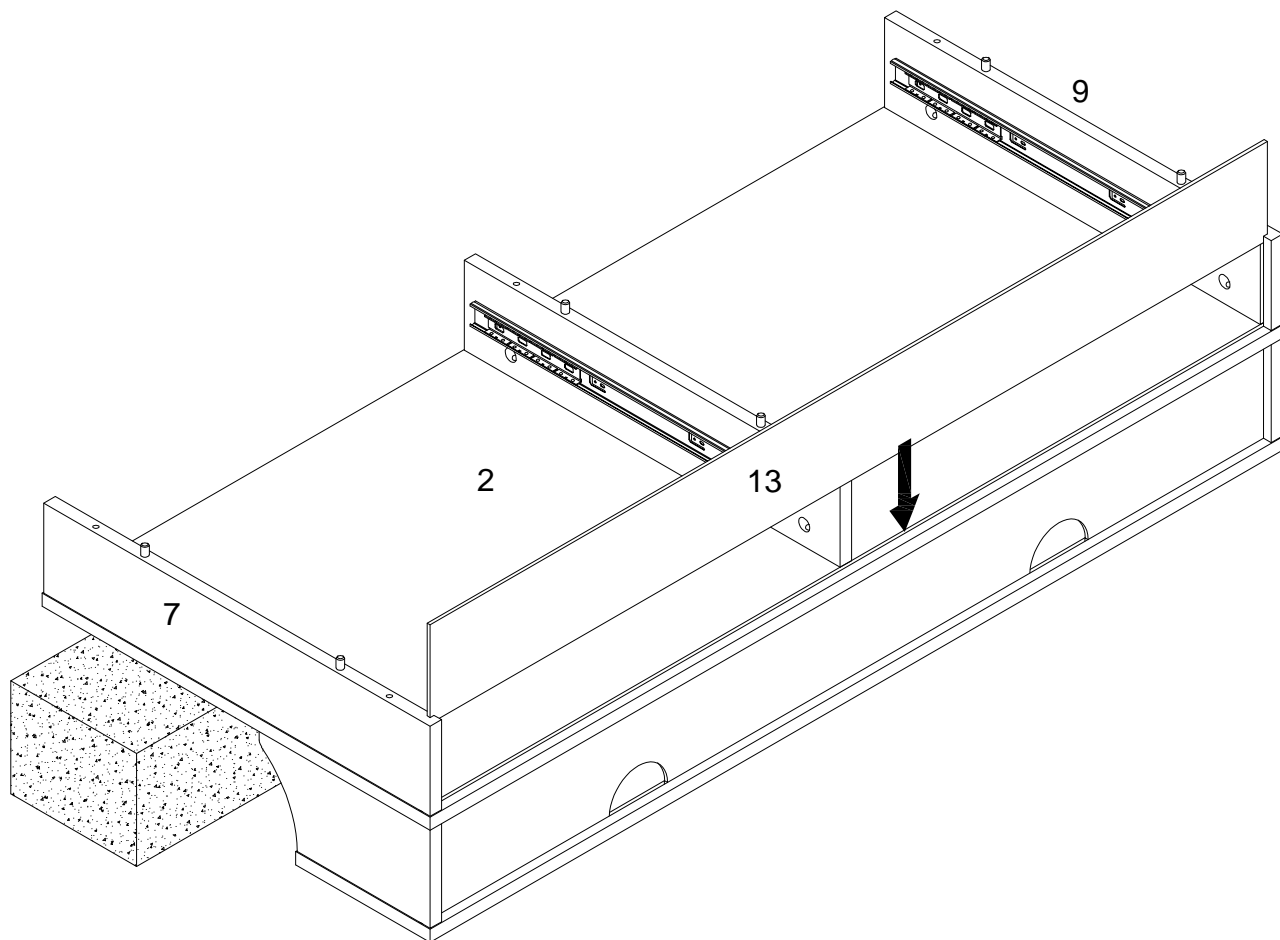

Put part (13) as per diagram.

Step 11

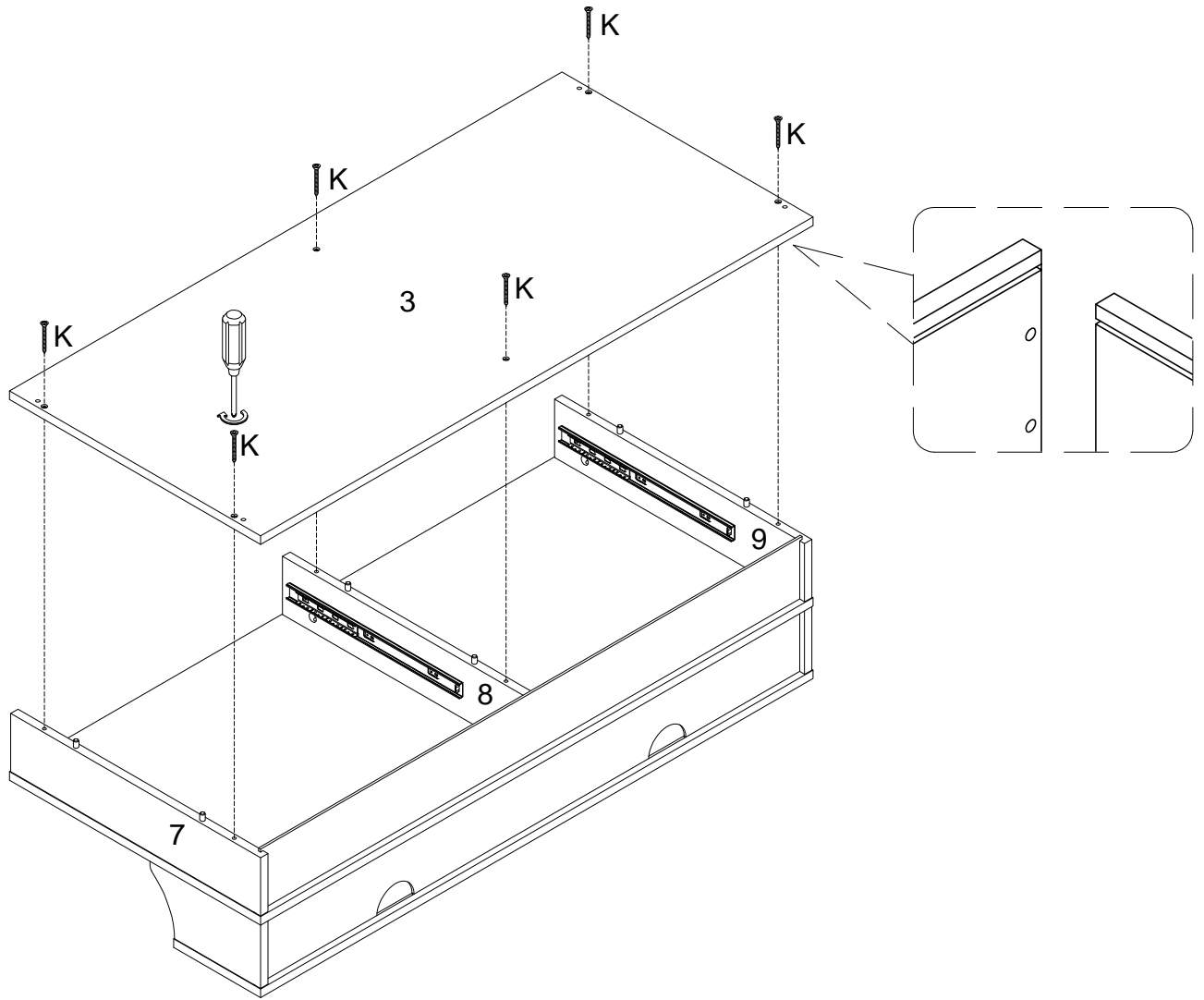

Using screw (K) attach part (3) to parts (7,8,9) with Philips head screwdriver as per diagram.

Step 12

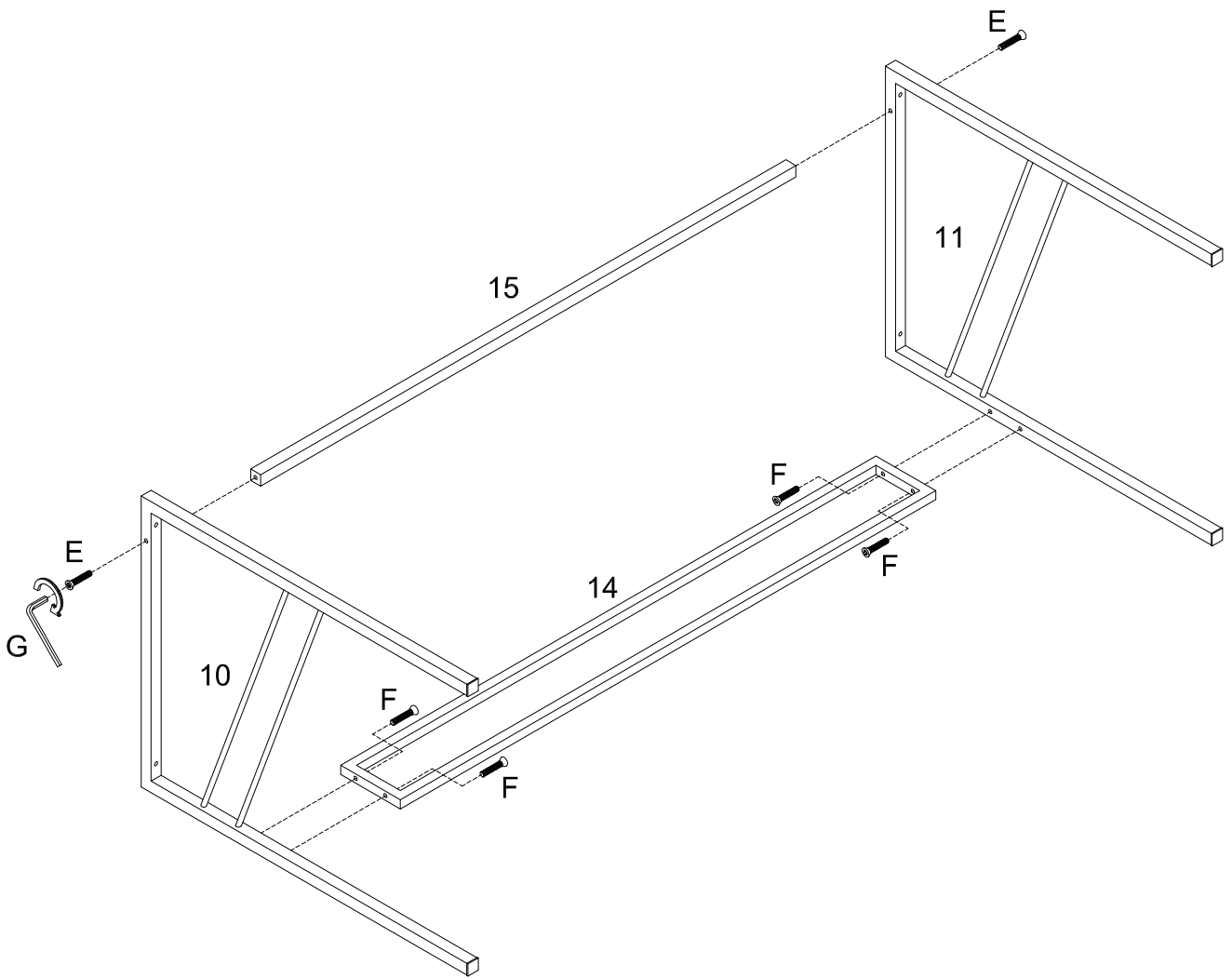

Using Bolt (E) attach parts (10,11) into part (15), then using bolt (F) attach part (14) to parts (10,11) with Hex key (G) as per diagram.

Step 13

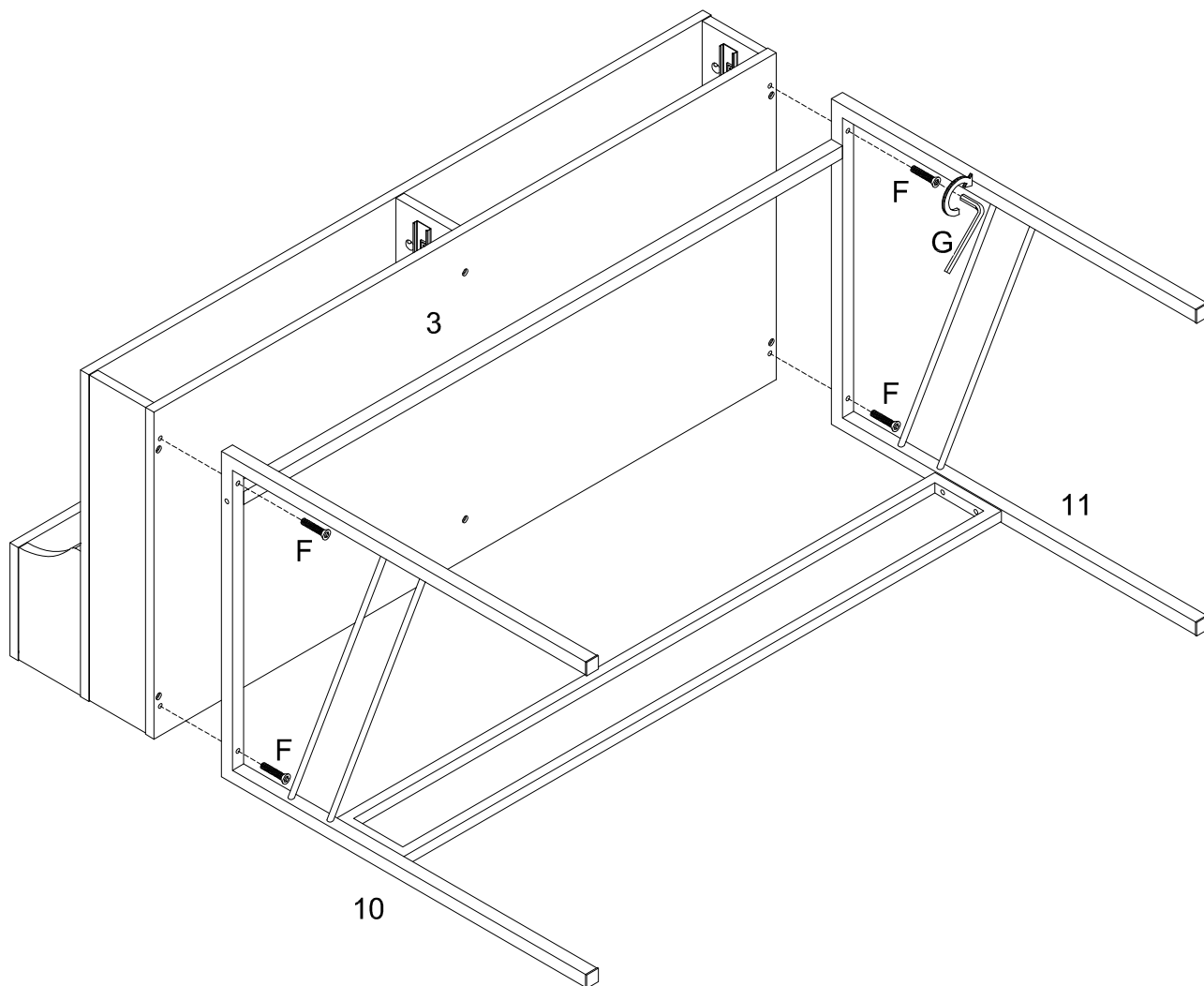

Using Bolt (F) attach parts (10,11) into part (3) with Hex key (G) as per diagram.

Step 14

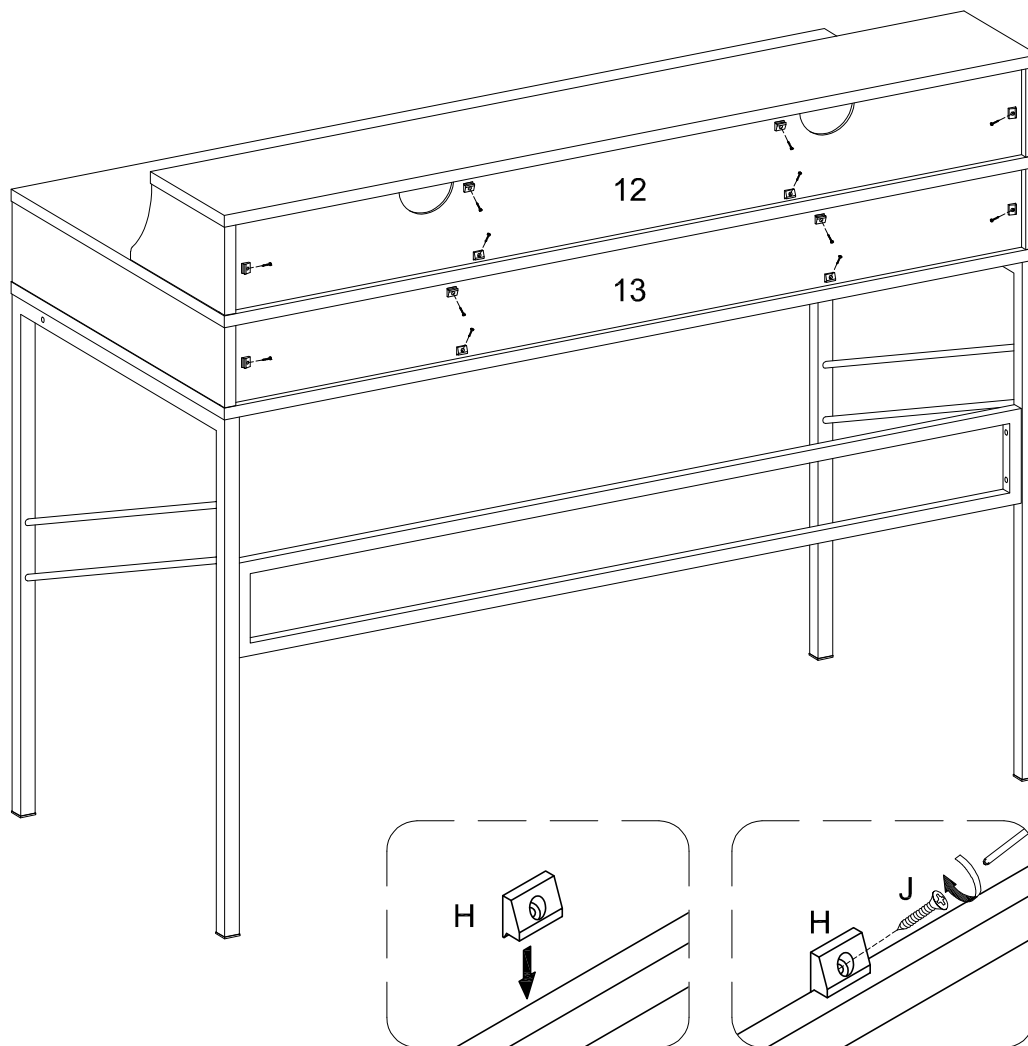

Using screw (J) secure plastic wedge (H) to parts (12,13) with Philips head screwdriver as per diagram.

Step 15

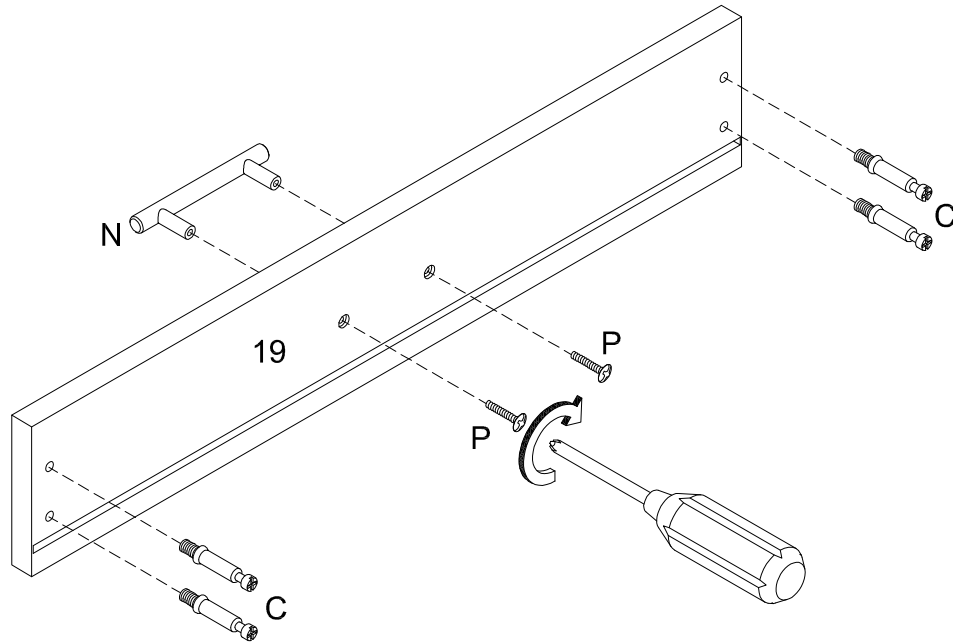

x 2

Secure cam bolt (C) into part (19) ,then using handle bolt (P) secure handle (N) to part (19) with Philips head screwdriver as per diagram.

Step 16

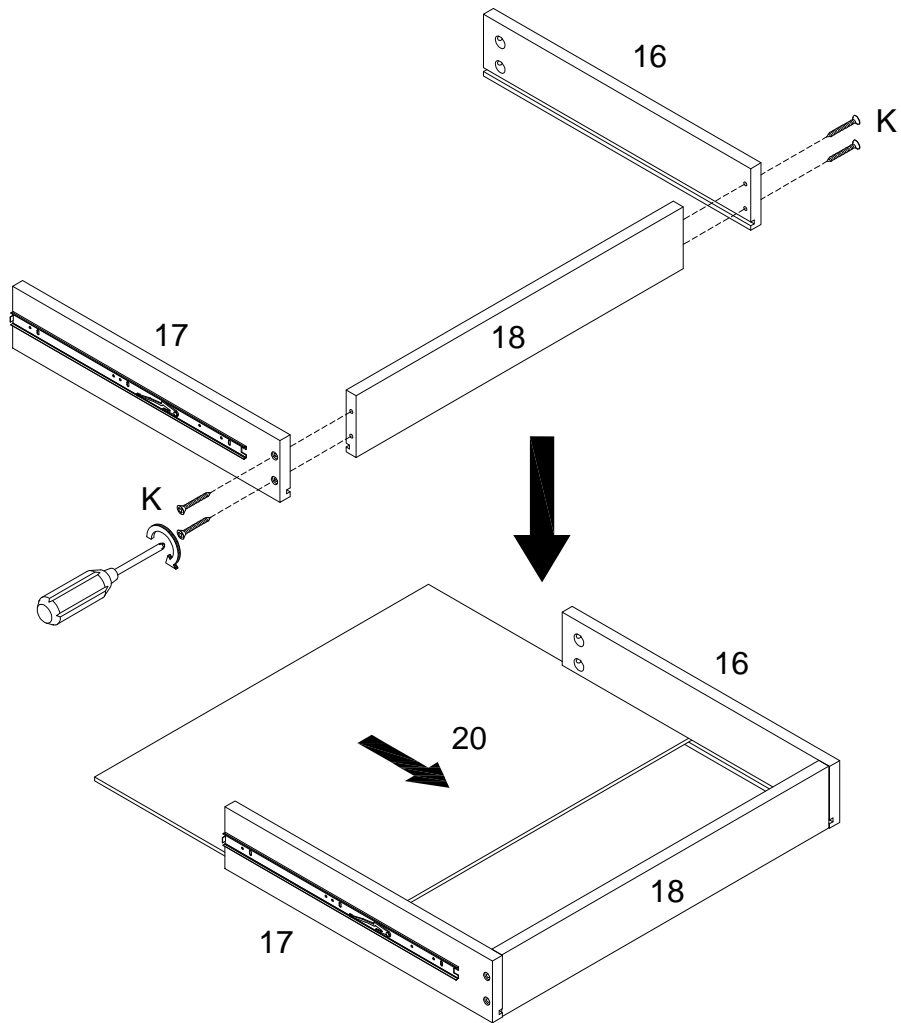

Using screw (K) attach parts (16,17) to part (18) with Philips head screwdriver ,then insert part (20) as per diagram.

Step 17

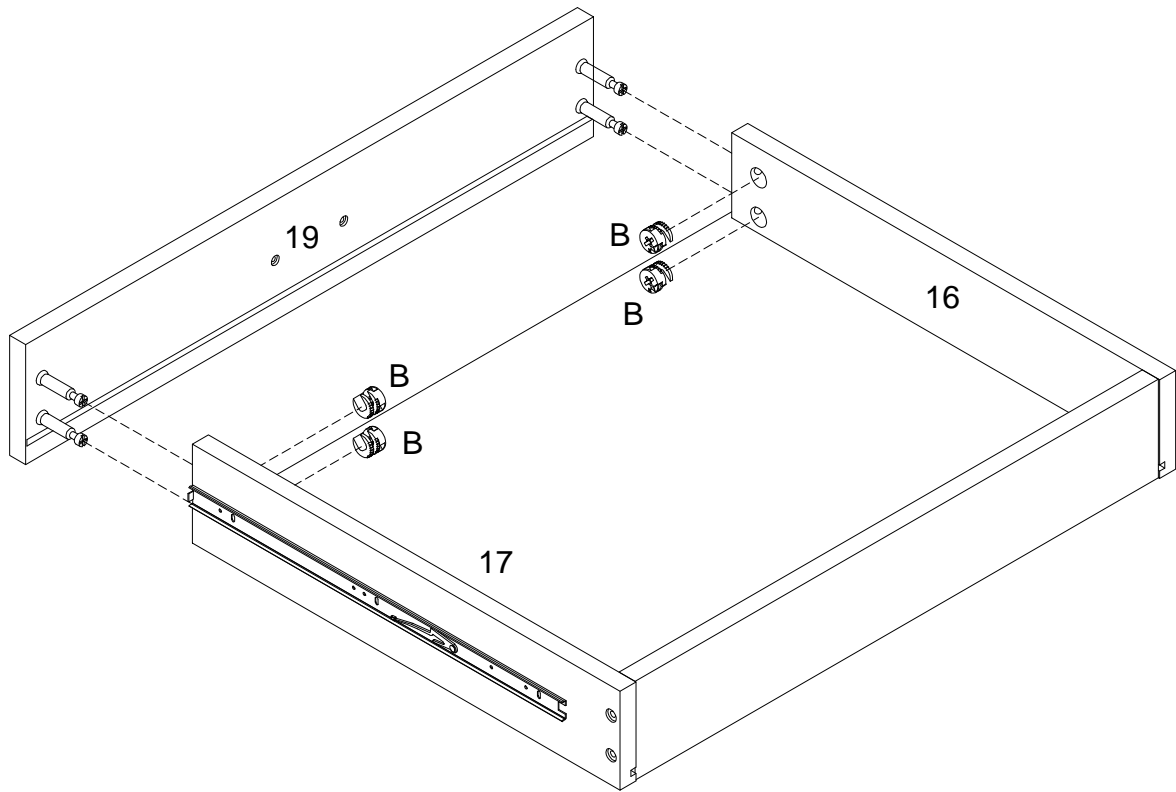
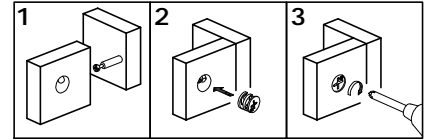

x 2

Using Cam lock (B) secure part (19) to parts (16,17) with Philips head screwdriver as per diagram.

Step 18

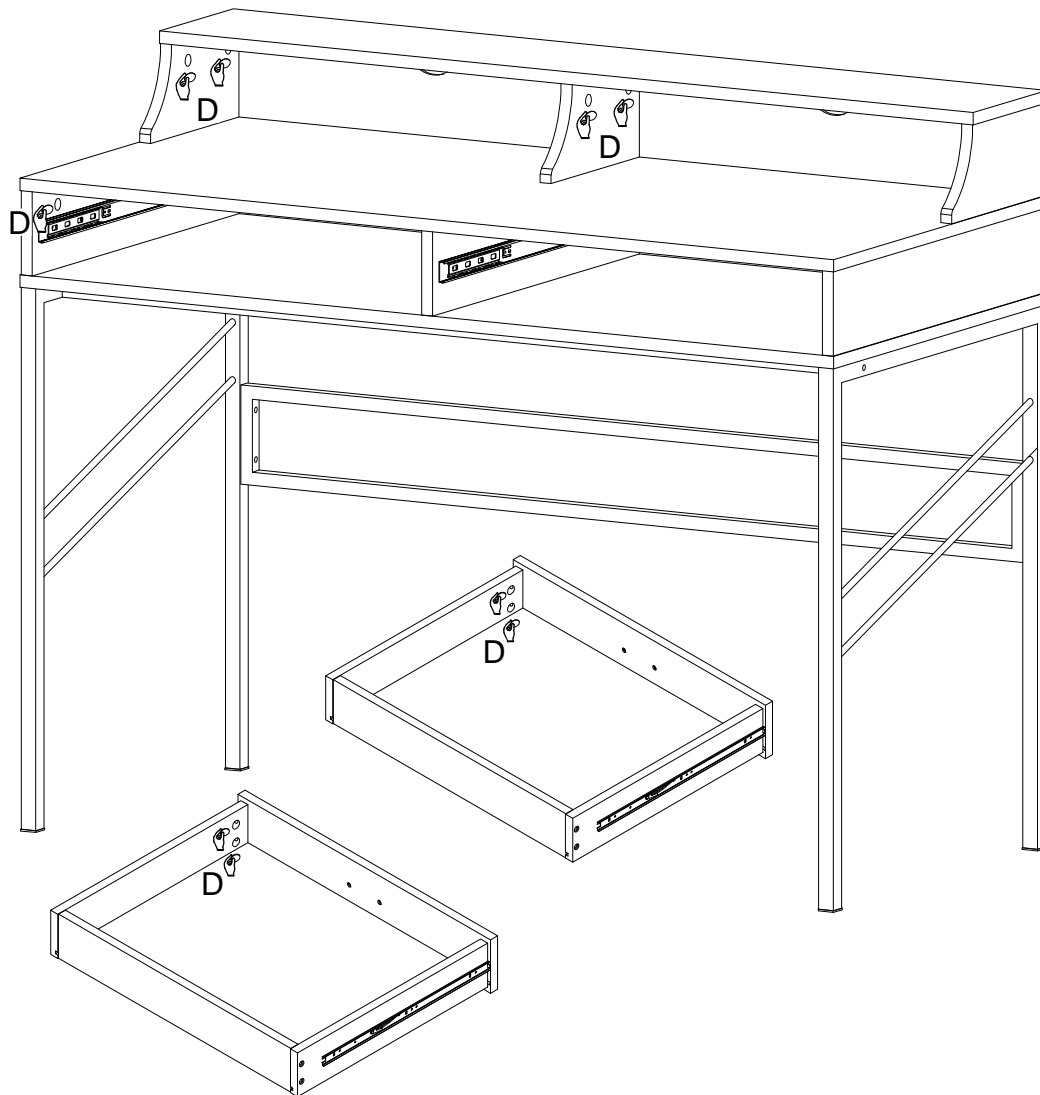

Place sticker (D) cover the holes as per diagram .

Step 19

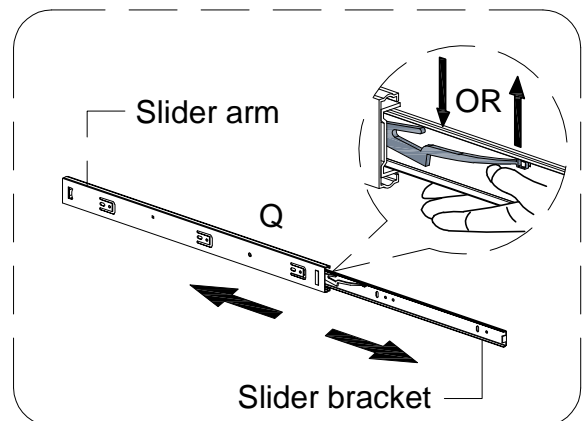
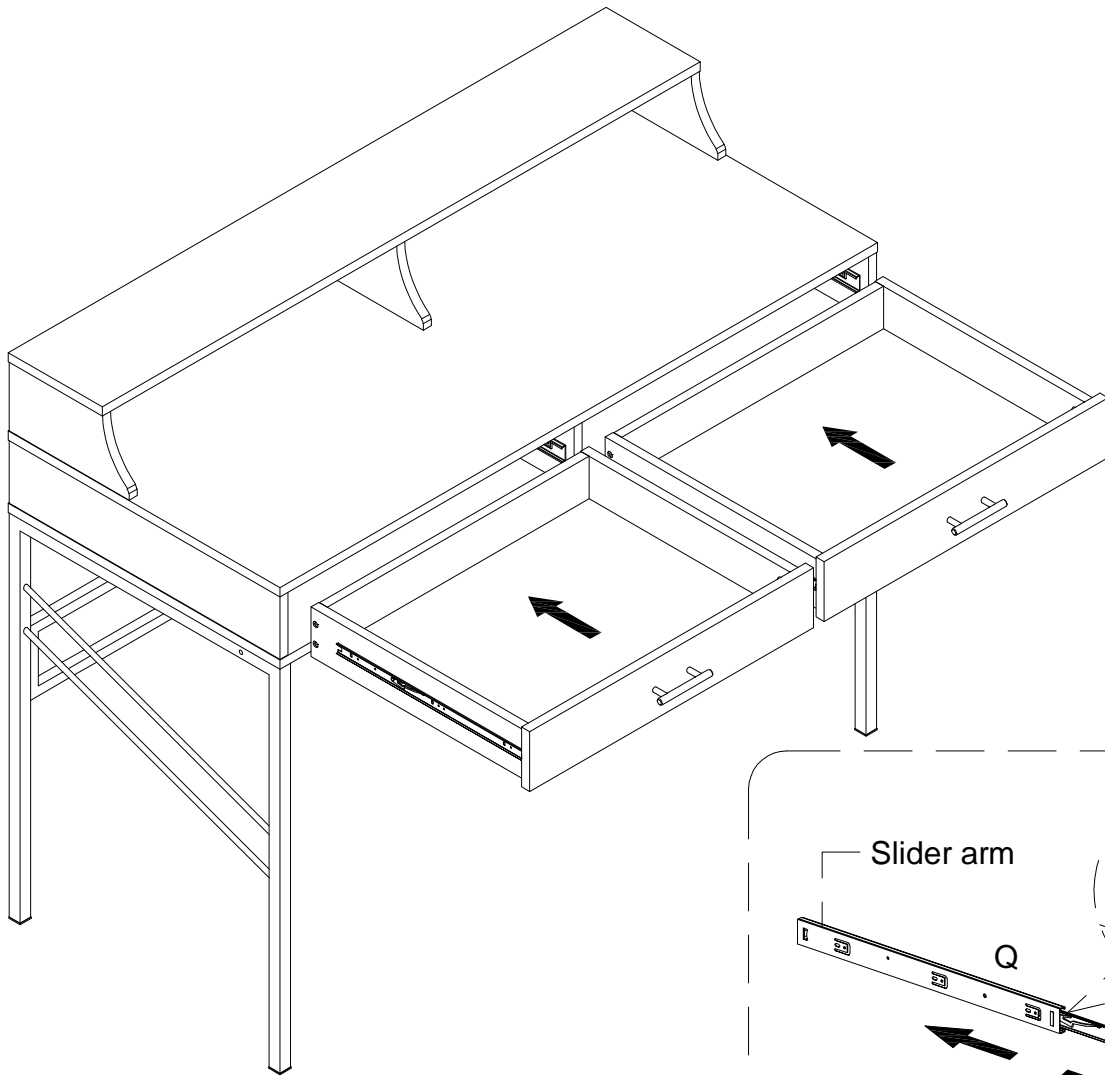

Insert the assembled drawers into the unit frame, extend the Ball Bearing Slide Tracks (Q) on the pedestal Side Panel all the way forward .Then align the Slide Runners on the assembled drawers with the Slide Tracks and push the drawer carefully inside until it stops. Note : if the drawer does not go in smoothly, please take it out and repeat the step. If you need to remove the drawer, please pull the drawer all the way out,press or lift the plastic release lever and pull out the drawer and then re-assembled the drawer until it was going in smoothly .

Step 19

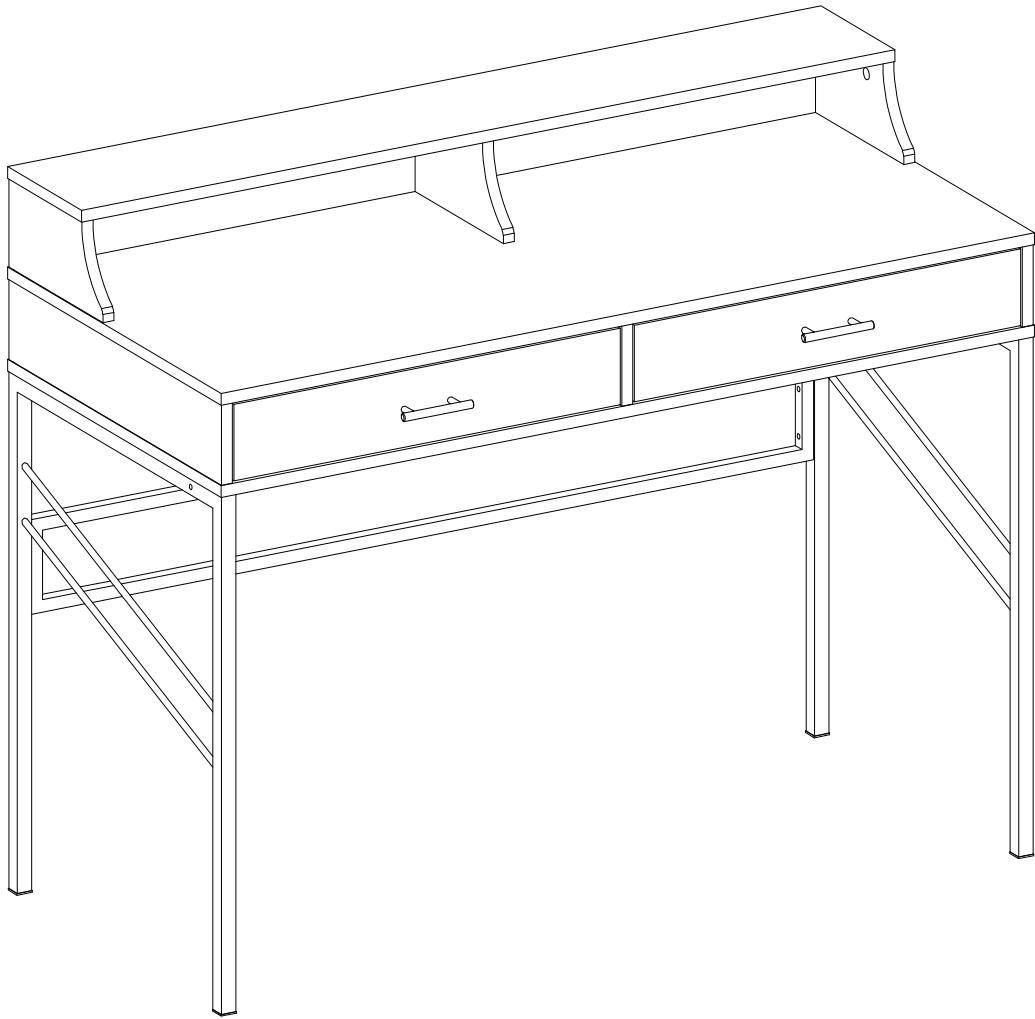

Final Assembly