

Assembly Instructions

Caution : You must read this before you proceed .

Please look in the bottom of Seat for hardware packs and legs.

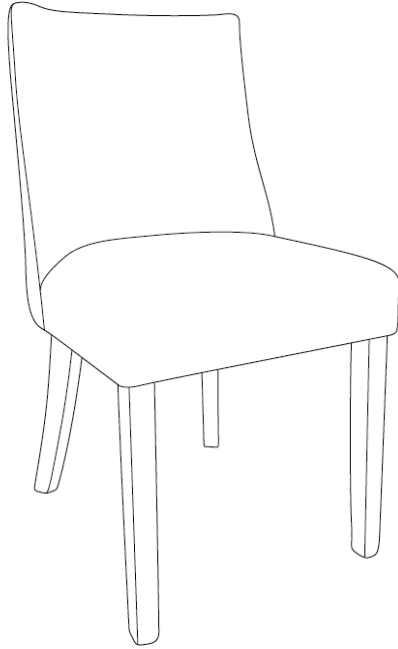



CHAIR



Parts List

Label	Picture	Description	QTY
A	A line drawing of the chair seat, showing its shape and the location of the hardware packs and legs at the bottom.	Chair Seat	1
B	Two line drawings of front legs, showing their shape and the hardware packs at the bottom.	Front Leg	2
C	Two line drawings of back legs, showing their shape and the hardware packs at the bottom.	Back Leg	2

Hardware

Label	Picture	Description	QTY
①		Bolt (M8*55mm)	9
②		Washer	9
③		Spring Washer	9
④		Allen Wrench	1

Assembly Preparation

Before Beginning Assembly:

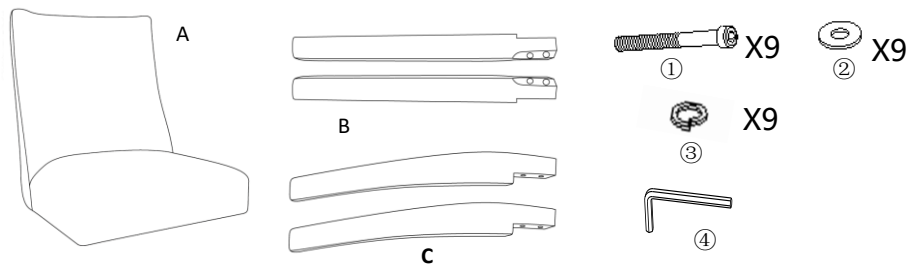

- Read instructions, cover to cover-



- Have 2 adults on hand for assembly-



- Do not assemble on flooring or carpet-



- Assemble on a clean non-marring surface (packing foam)-



- Save all packaging until finished-

Assembly steps

Overview

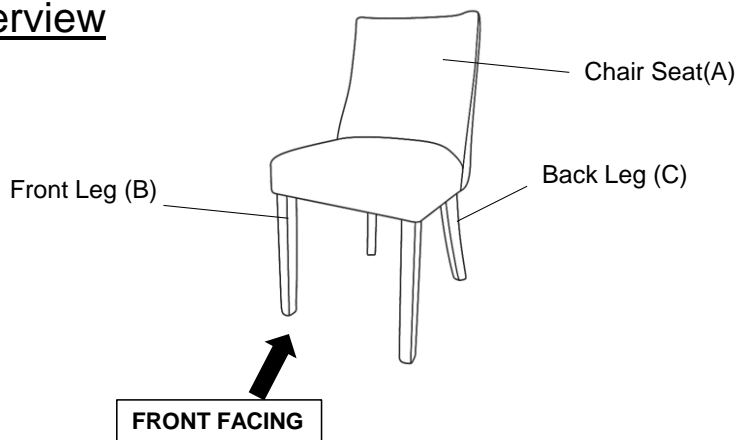

This Chair has multiple parts and may require up to 30 minutes to assemble. To give you an overview of the Chair parts, the above picture is to help you put the various parts into perspective. Please read through the instructions below to familiarise yourself with the parts and steps before assembly.

Step 1

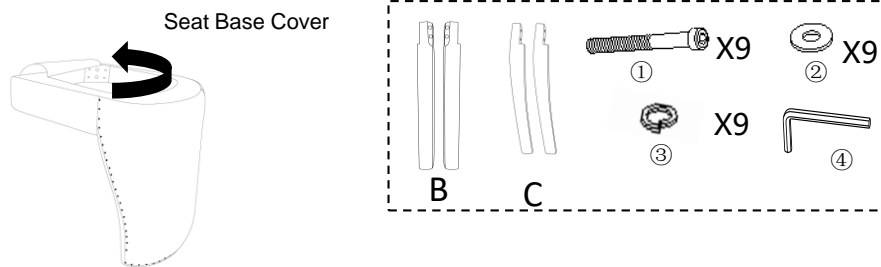

Place the Chair Seat(A) Face down on a soft surface to avoid any scratches or damages to the product.

Carefully open the Seat Base Cover from the edge of the zipper, take out the legs and hardware from the bottom of the Seat.

Step 2

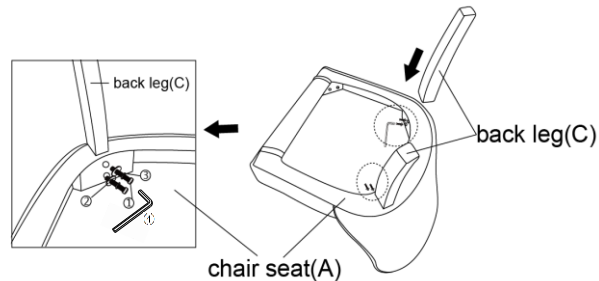

Put the Chair Seat(A) onto a flat, clean, non-marring table.

Attach the Back Leg(C) to the Chair Seat(A) using Bolts(1), Spring Washers(3) and Washers(2) with the Allen Wrench(4) as shown above.

Do not fully tighten Bolts.

Step 2

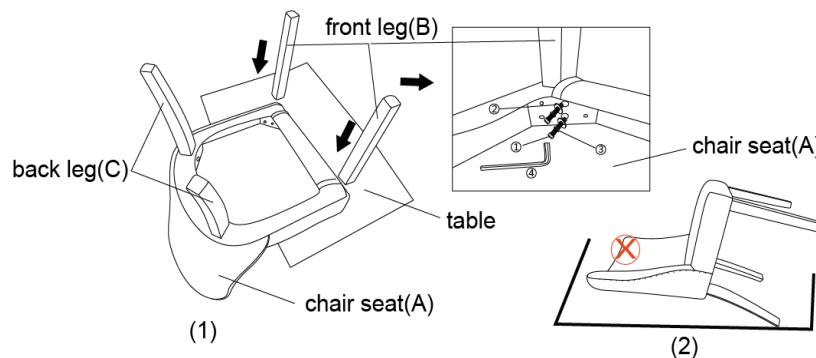

Place the chair onto the side of a table as seen in picture 1.

Attach the Front Legs(B) to Chair Seat(A) using Bolts(1), Spring Washers(3) and Washers(2) with Allen Wrench(4).

Do not fully tighten the Bolts.

WARNING!! DO NOT POSITION THE FRONT LEG AS SHOWN IN PICTURE 2.

THIS PICTURE SHOWS THE CHAIR BACK AGAINST THE GROUND and THE FRONT LEGS HORIZONTAL IN MIDAIR.
WARNING!! DO NOT OVER TIGHTEN. OVER TIGHTENING COULD LEAD TO DAMAGE OF THE PRODUCT.
TIGHTEN ONLY UNTIL SECURE AND STABLE.

Step 3

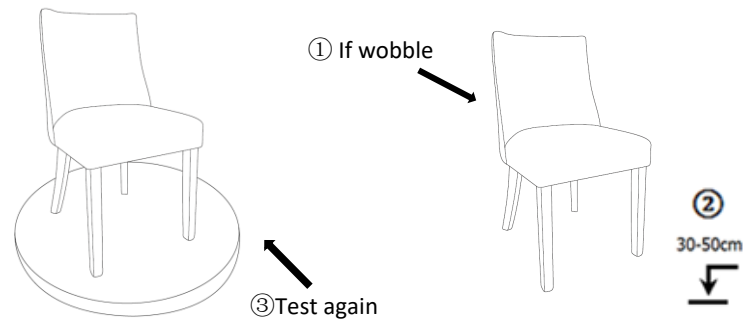

Place the Chair on a Level Surface to see if it wobbles.
If it wobbles, lift the Chair some 30cm to 50cm above the ground.
Keep your feet and toes well away from the drop zone.
Drop the Chair freely and vertically with all four legs, hitting the ground, at the same time.
This Drop Test will help to ensure that all Bolts and gaps reach full alignment status.
Test again for evenness on a Level Surface.
If no wobbles are found, proceed to tighten all the Bolts.
Note: When tightening the Bolts, tighten sequentially. Do not tighten any Bolt fully and then move towards the next one. This could cause the frame to warp.
If there are still wobbles, loosen the Bolts and execute this same drop test.
Note: If the Chair is not stable, it could lead to damage to the product.

Step 4

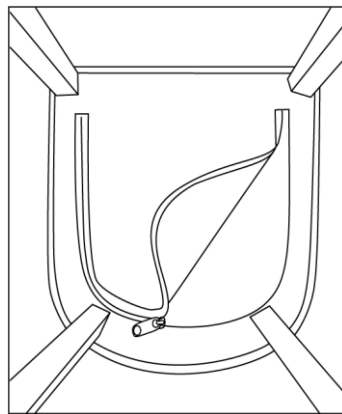

Place the Seat Base Cover back as shown in the picture.
Zip up the seat base cover with your hand on all four sides at the edge of the seat.
Make sure all parts are connected and securely locked into position.
Then stand the Chair right side up.
Your Chair is ready for use.
This Chair can only be used on a flat, level surface.

Care & Maintenance



- Furniture may scratch floors. We recommend using furniture pads to protect your floors.



- Do not put hot items directly on furniture surface.



- Do not clean furniture with harsh cleansers or polish.



- Do not place furniture under direct sunlight.



- Do not place furniture near heating or cooling vents.



- Do not write on furniture without a padded barrier to protect the surface.



- Do not place furniture outside . For indoor use only.



- Not for commercial use. For residential use only.



- Stains may be removed with mild soap solution and damp cloth.



- Children should not climb or jump on the furniture.



- Dust and pick-up spills using a clean, non-colored, lint-free cloth.