













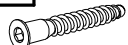

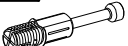
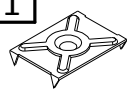

INSTRUKCJA MONTAŻU ASSEMBLY INSTRUCTIONS

Akcesoria / Fittings						
Q1 	W1  Ø3 × 16	W3  Ø3,5 × 16	W4  Ø4 × 16	W5  Ø4 × 35	W6  Ø6.3 × 50	G1 
1 szt. / pcs	8 szt. / pcs	20 szt. / pcs	13 szt. / pcs	3 szt. / pcs	22 szt. / pcs	36 szt. / pcs
Q2 	M1 	M2 	T1 	N1 	N2 	K1  Ø8 × 35
1 szt. / pcs	10 szt. / pcs	10 szt. / pcs	9 szt. / pcs	2 szt. / pcs	2 szt. / pcs	10 szt. / pcs
U1 	U2  Ø4 × 30	TZ1 	S1 	ZM1 	ZW1 	B1 
4 szt. / pcs	4 szt. / pcs	1 szt. / pcs	4 szt. / pcs	10 szt. / pcs	22 szt. / pcs	8 szt. / pcs
P1-A 	P1-B 	P2-A 	P2-B 			
2 szt. / pcs	2 szt. / pcs	2 szt. / pcs	2 szt. / pcs			

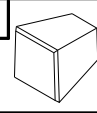
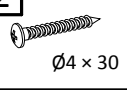
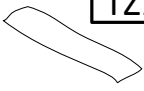
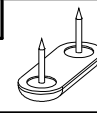
Narzędzia / Tools		
		

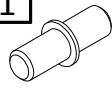
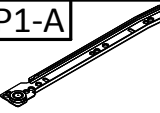
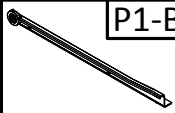
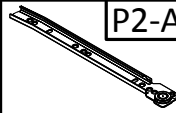
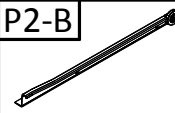
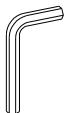
**DO MONTAŻU POTRZEBNE SĄ DWIE OSOBY!
INSTALLATION REQUIRES TWO PEOPLE!**

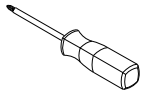
BARDZO WAŻNE!
NALEŻY UWAŻNIE PRZECZYTAĆ
ZACHOWAĆ DO PÓŹNIEJSZEGO STOSOWANIA

INSTRUKCJA OBSŁUGI

1.

By zapobiec zadławieniu lub uduszeniu opakowanie z akcesoriami należy trzymać w miejscu niedostępnym dla niemowląt i dzieci.

2.

Wszystkie połączenia w meblu muszą być dobrze dokręcone, żaden z elementów łączących nie może być luźny.

3.

Nie należy używać regału jeśli jakkolwiek element jest uszkodzony lub brakuje elementu.

4.

Należy używać tylko elementów dopuszczonych przez producenta.

5.

Nie należy w pobliżu regału umieszczać otwartych źródeł ognia oraz innych silnych źródeł ciepła, jak promienniki gazowe lub elektryczne itp., gdyż grozi to pożarem.

6.

Regał należy przytwierdzić do ściany za pomocą dołączonej taśmy zabezpieczającej!

VERY IMPORTANT!
PLEASE READ CAREFULLY
SAVE FOR FUTURE USE

USER'S MANUAL

1.

To avoid the danger of choking or strangulation keep the package with fittings away from babies and children.

2.

All connections must be tightened properly and no coupled element can not be loose.

3.

Do not use the bookstand when, if any of the elements is damaged or if there is any element missing.

4.

Use only the elements given by manufacturer.

5.

Do not place the bookstand near naked flames or other heat sources such as electric or gas radiators etc., this may cause a fire.

6.

The bookstand must be fixed to the wall using the supplied roll-over protection tape!

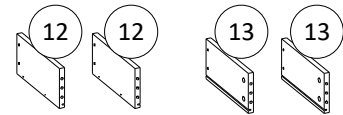
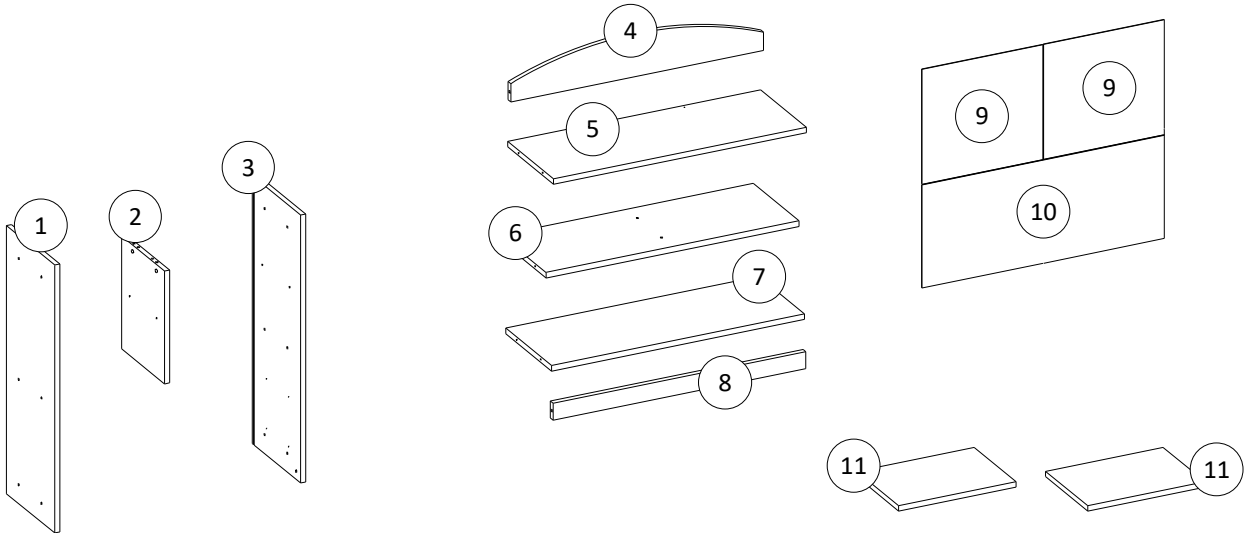

Paczka 1 z 1 / Package 1 of 1		
Numer elementu / Item no.	Wymiary (mm) / Dimensions (mm)	Ilość / Quantity
1	890 x 340 x 18	1
2	364 x 307 x 18	1
3	890 x 340 x 18	1
4	846 x 140 x 18	1
5	846 x 307 x 18	1
6	846 x 307 x 18	1
7	846 x 307 x 18	1
8	846 x 56 x 18	1
9	431 x 390 x 3	2
10	864 x 372 x 3	1
11	414 x 297 x 18	2
12	300 x 138 x 18	2
13	300 x 138 x 18	2
14	785 x 120 x 18	2
15	842 x 188 x 18	2
16	803 x 304 x 3	2

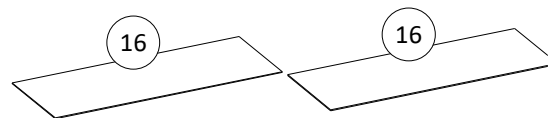
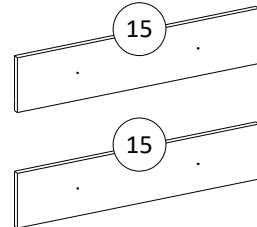
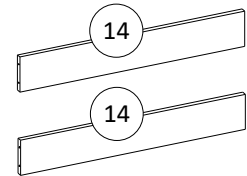

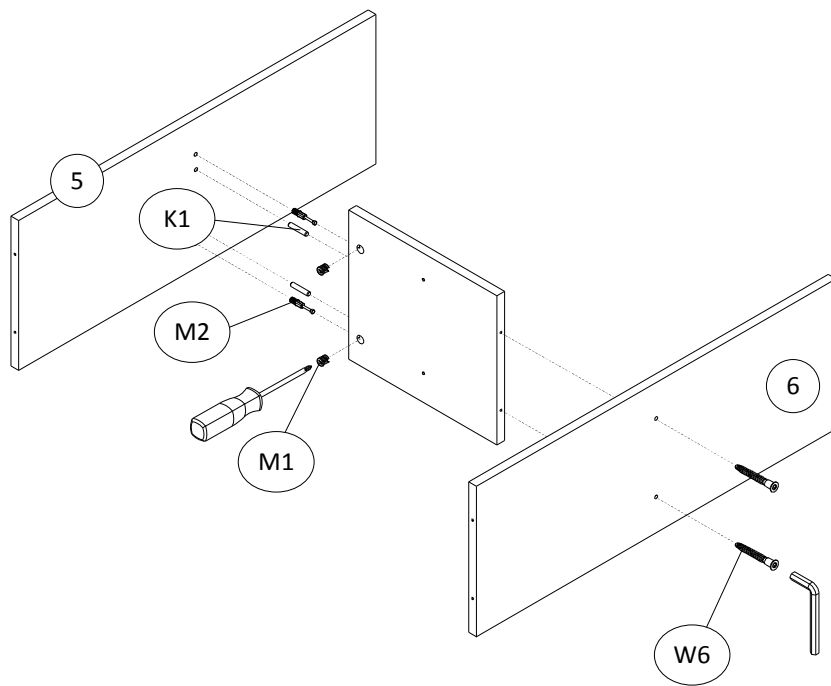
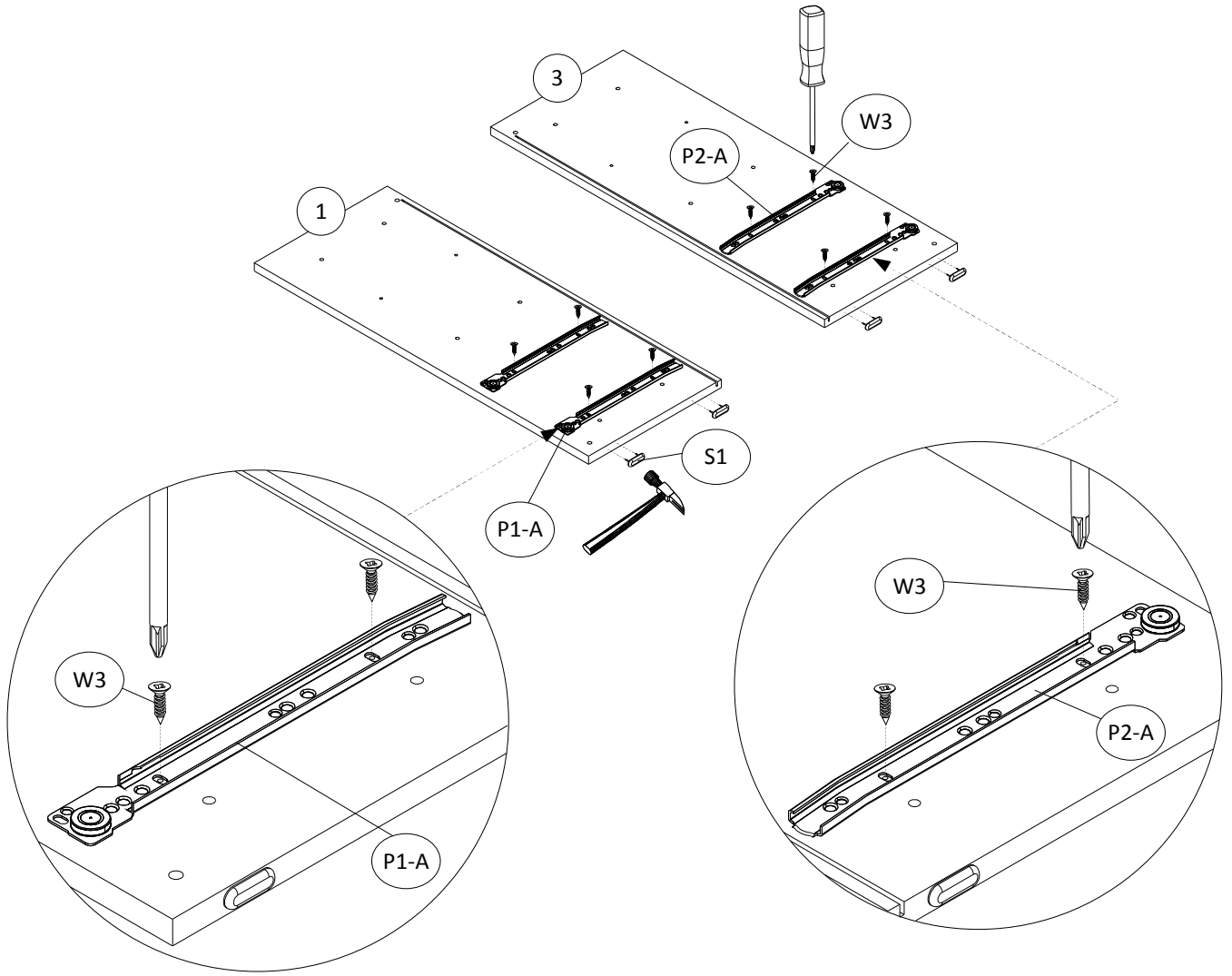

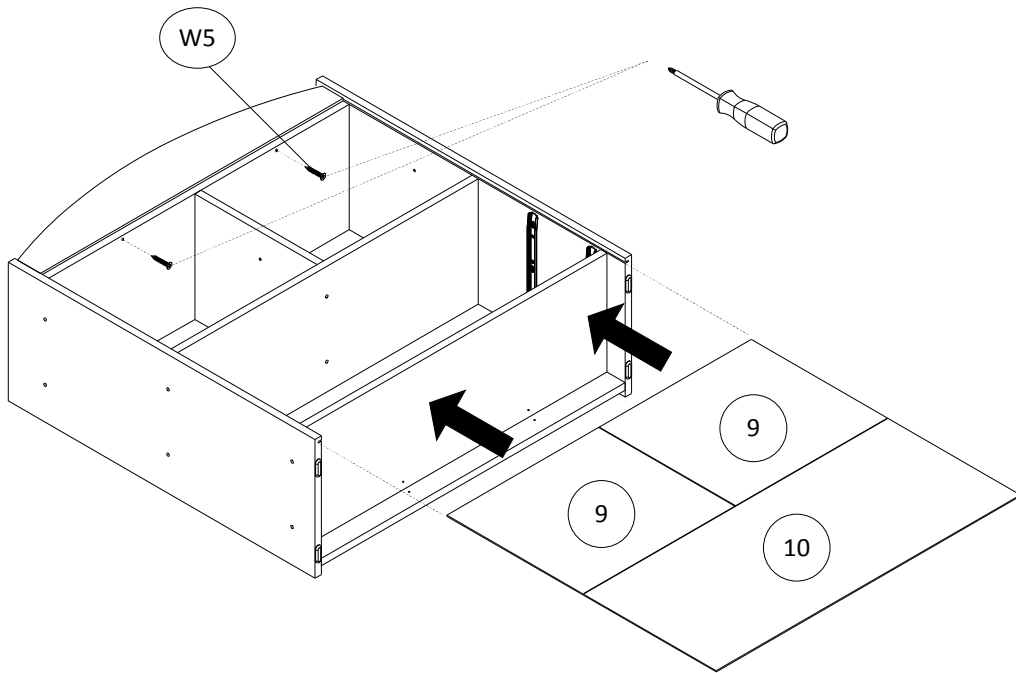
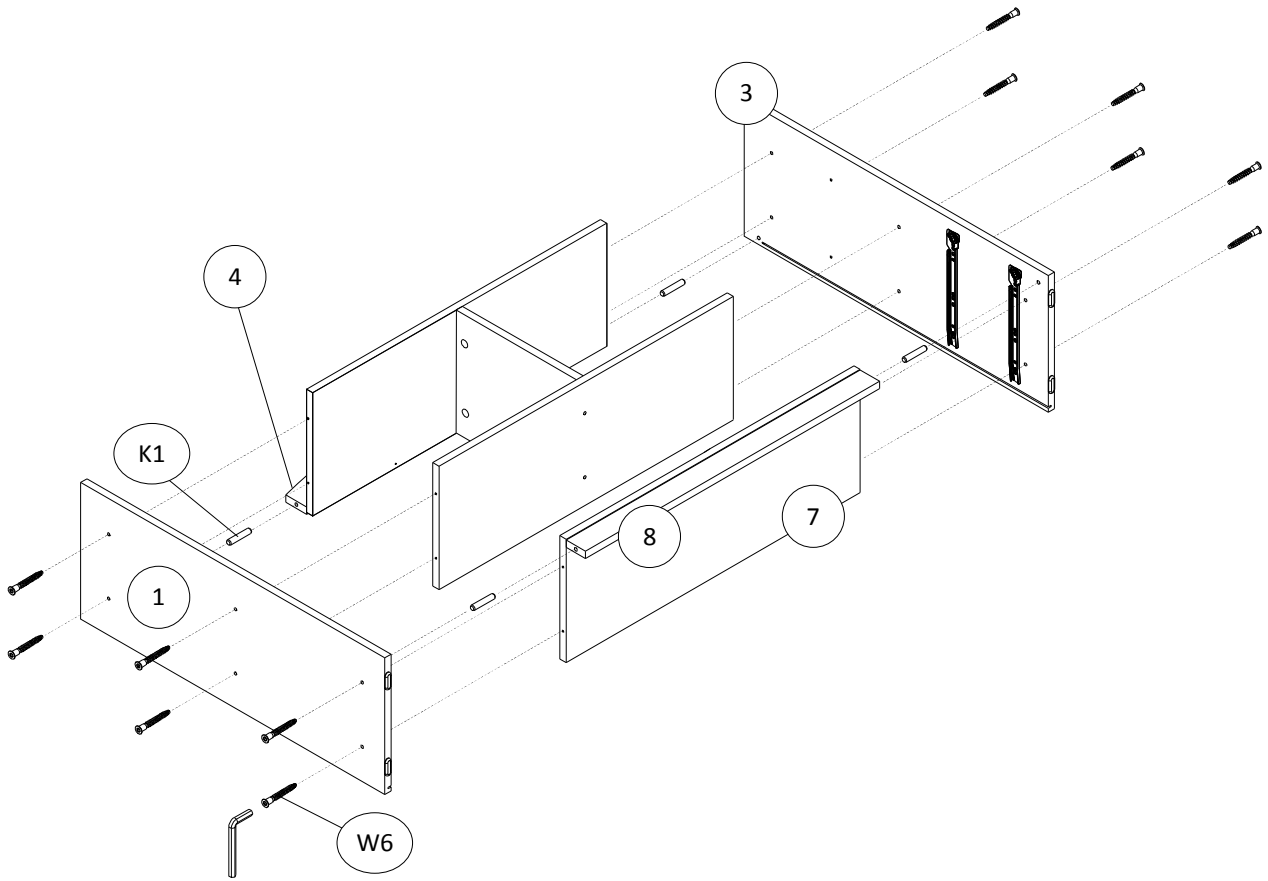

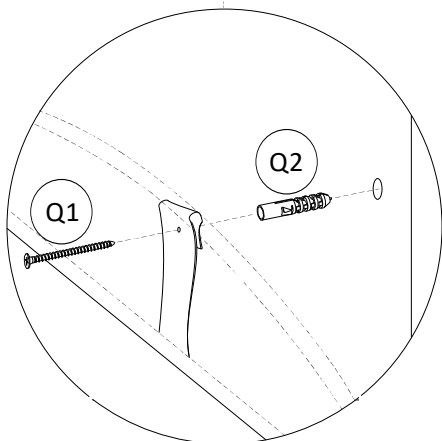
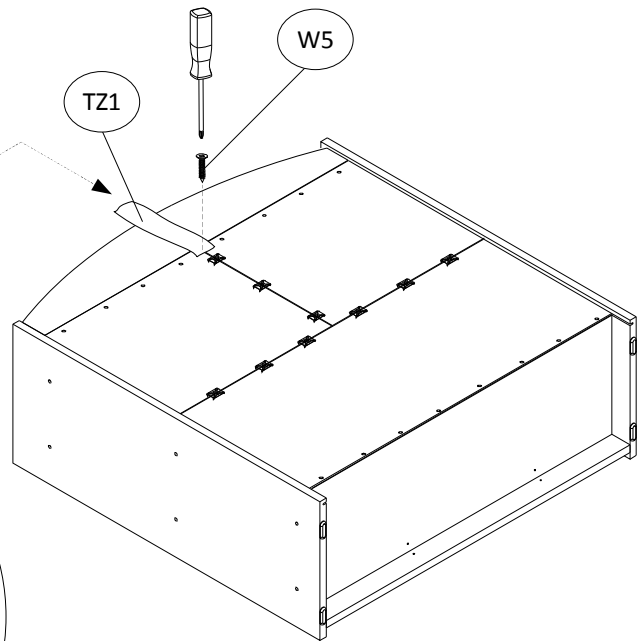
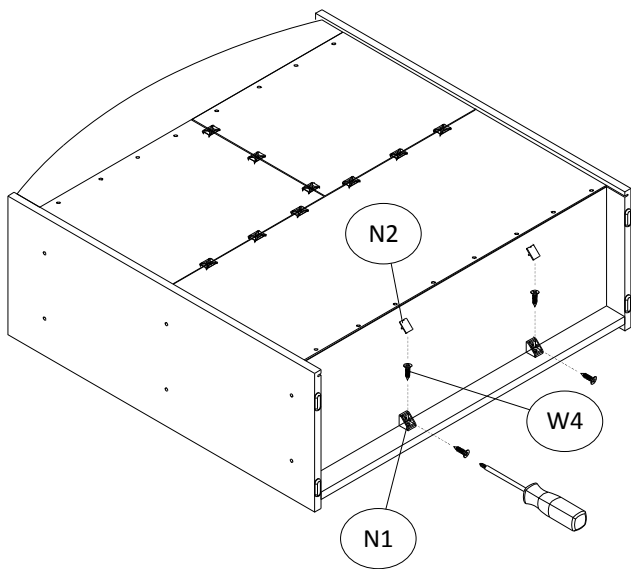
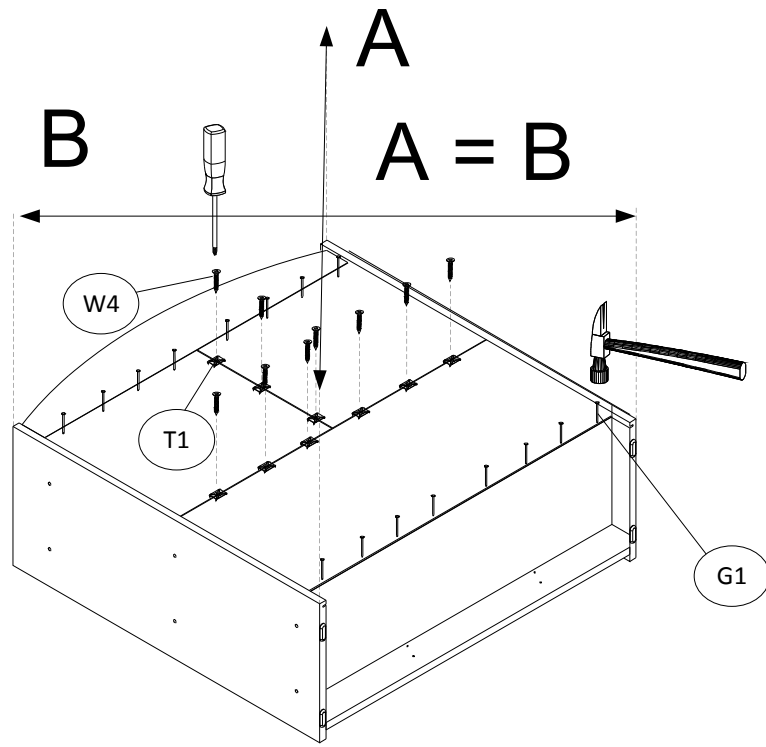

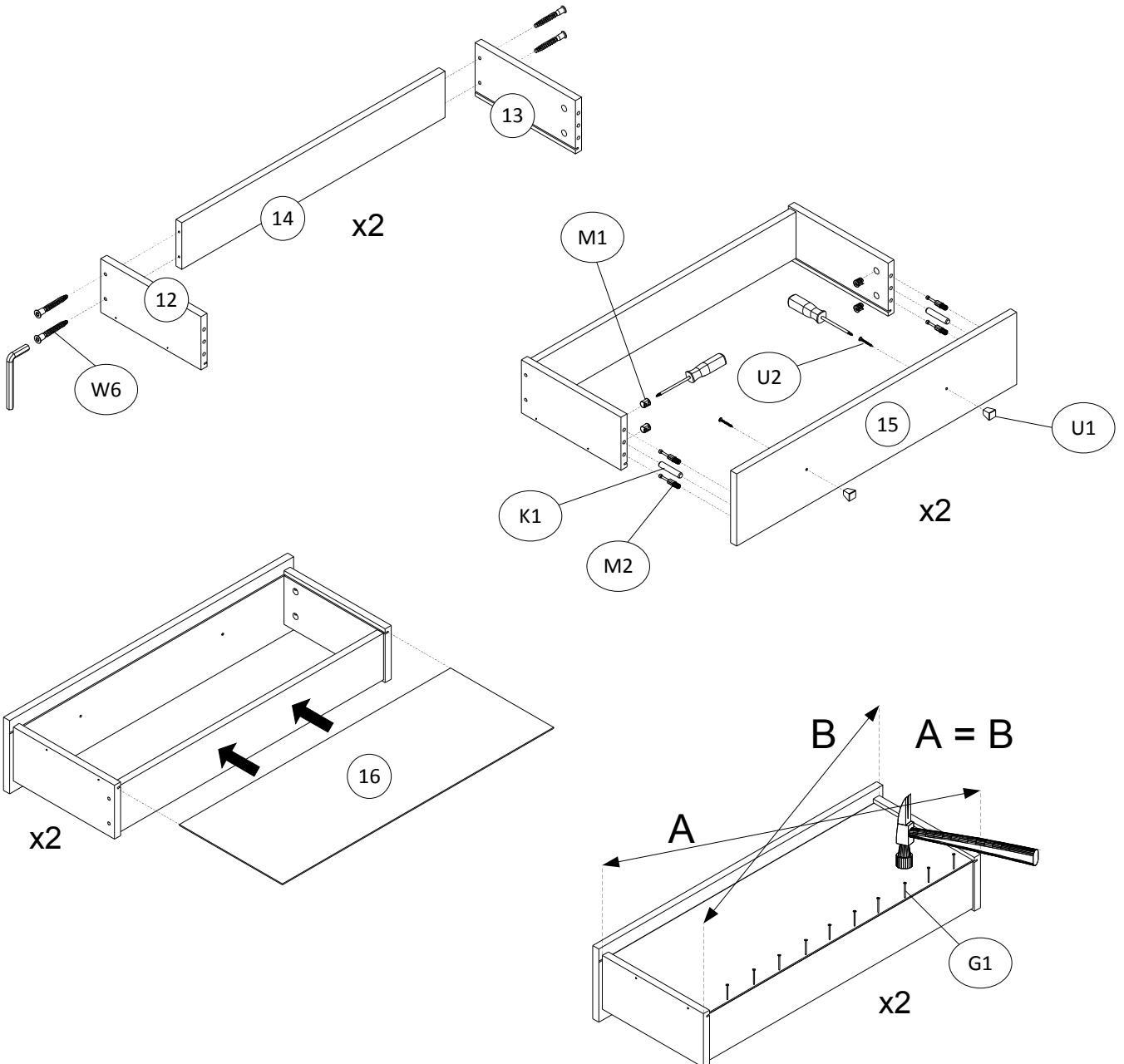

Na widocznych śrubach (W6)
należy umieścić dostarczone
zaślepki samoprzylepne (ZW1).

Na mimośrodkach (M1) należy
umieścić dostarczone plastikowe
zaślepki (ZM1).

On the visible screws (W6)
should be placed supplied
adhesive caps (ZW1).

On the eccentrics (M1) should be
placed supplied plastic caps
(ZM1).

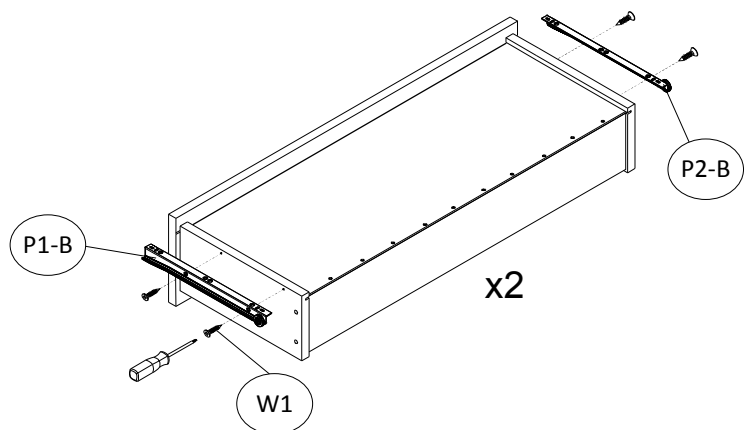

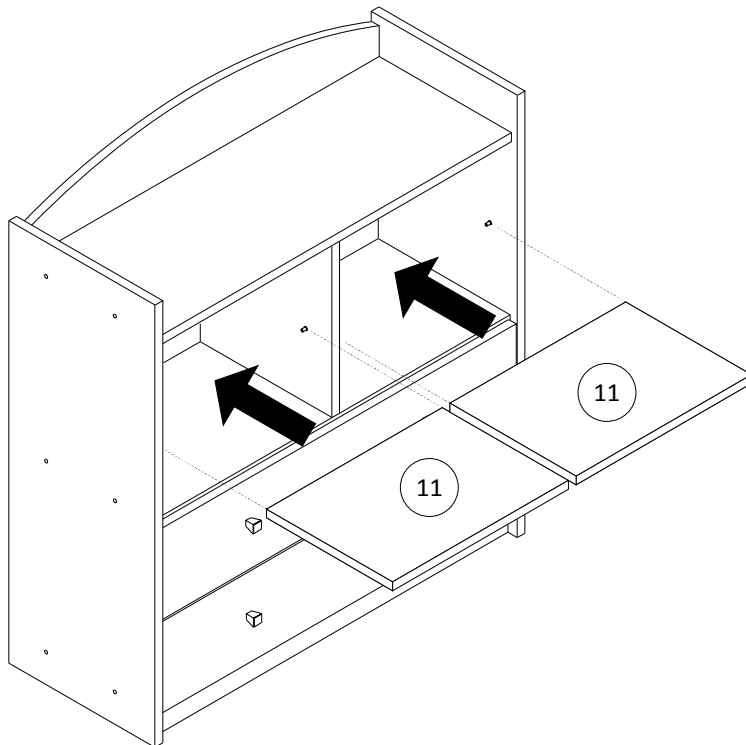
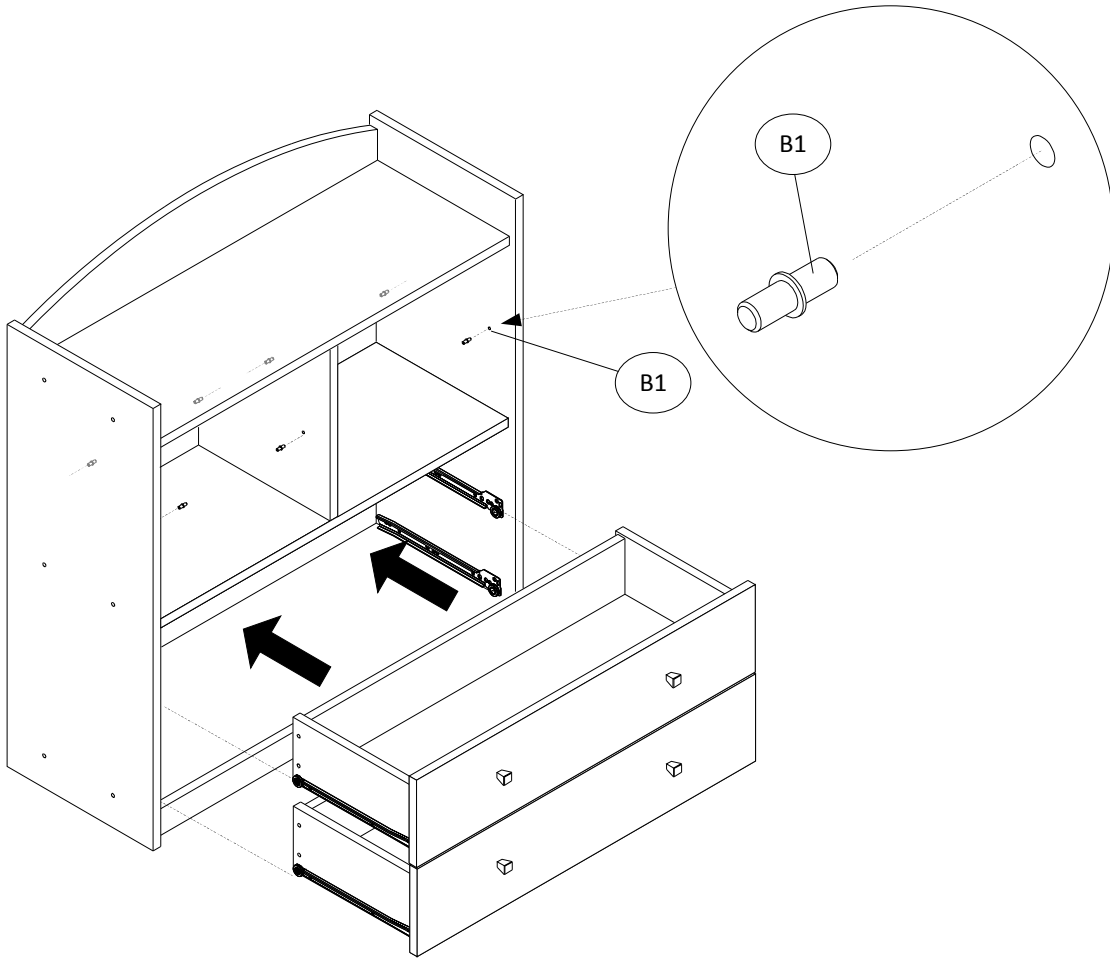

REGULACJA PROWADNIC SZUFLAD

DRAWER RUNNERS ADJUSTMENT

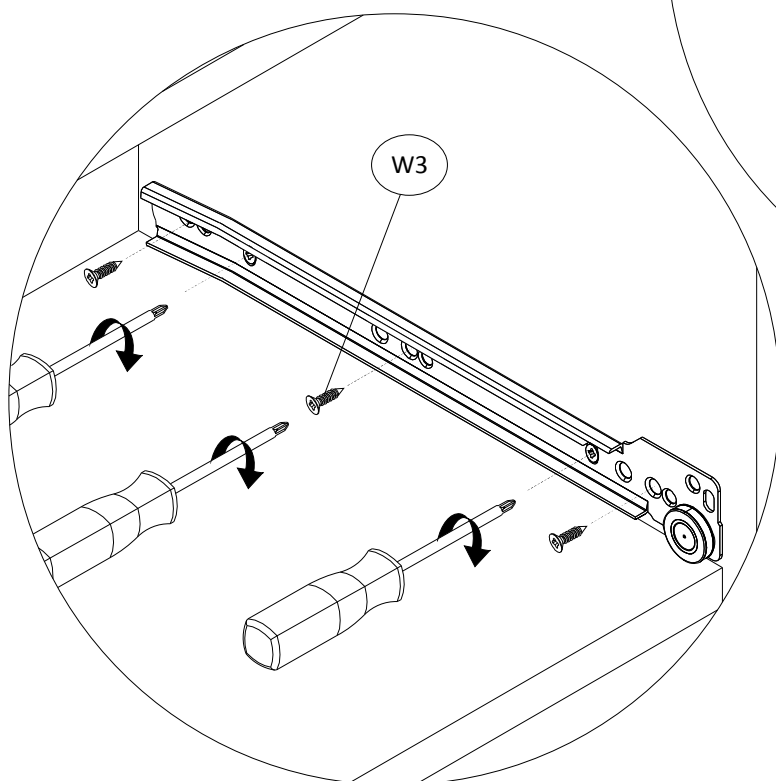
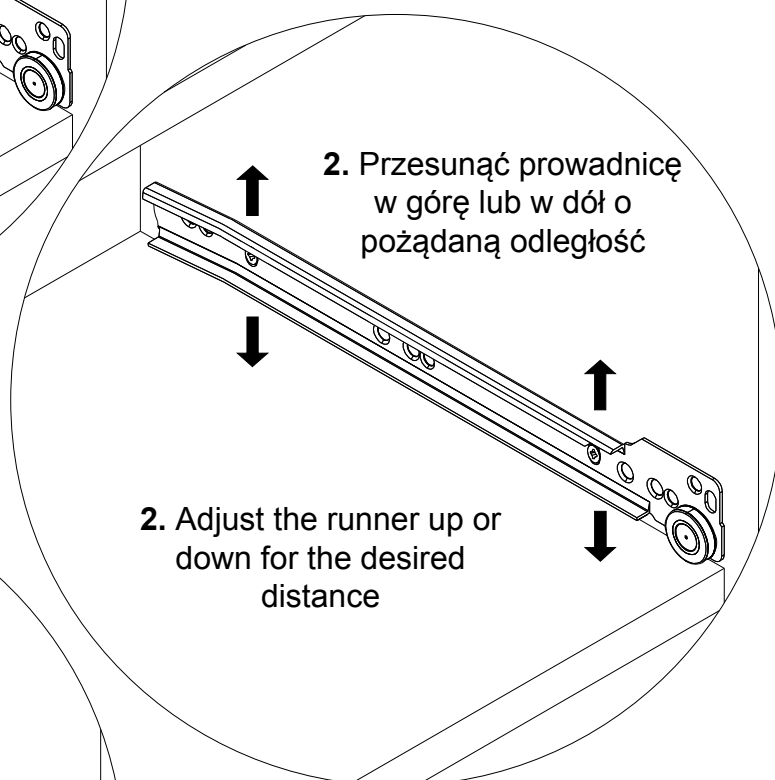
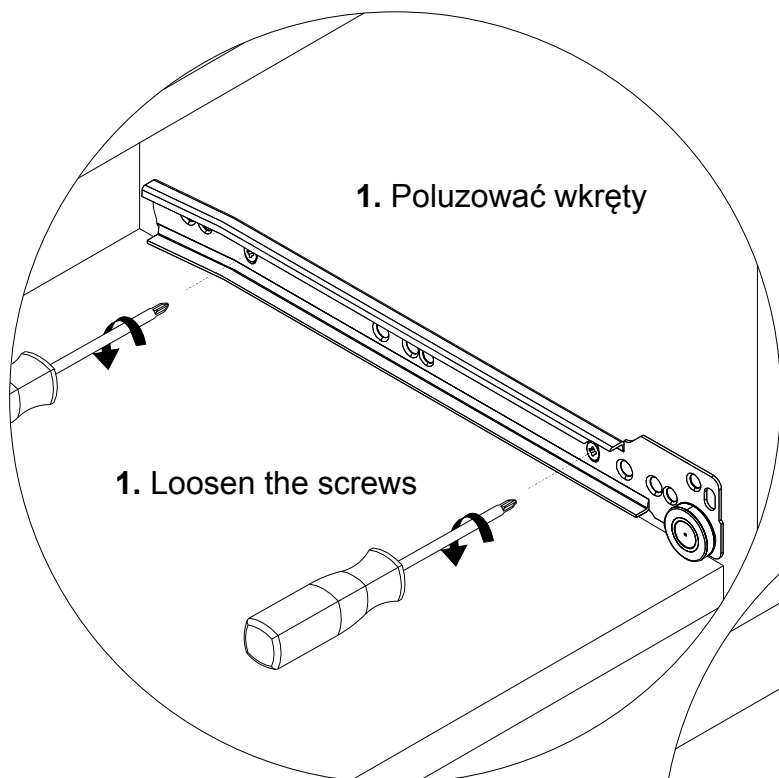

3. Dokręcić poluzowane wcześniej wkręty.

4. Wsunąć szuflady i sprawdzić ich położenie.

5. Jeśli szuflady leżą prawidłowo wkręcić dla stabilizacji kolejne 3 wkręty.

3. Tighten the screws loosened earlier.

4. Slide the drawer and check their positions.

5. If the drawers are mounted properly tighten another 3 screws to stabilize each drawer runner.

W razie konieczności czynności powtórzyć.

If necessary, repeat the steps.