

Pure & Easy



ASSEMBLY INSTRUCTIONS

NOTICE

IMPORTANT, RETAIN FOR FUTURE REFERENCE: READ CAREFULLY

WICHTIG, FÜR SPÄTERE NACHSCHLAGE AUFBEWAHREN: SORGFÄLTIG LESEN

IMPORTANTE, GUARDAR PARA REFERENCIA POSTERIOR: LEER ATENTAMENTE

IMPORTANTE, CONSERVARE PER RIFERIMENTI FUTURI: LEGGERE ATTENTAMENTE

IMPORTANT, À CONSERVER POUR RÉFÉRENCE FUTURE : LIRE ATTENTIVEMENT

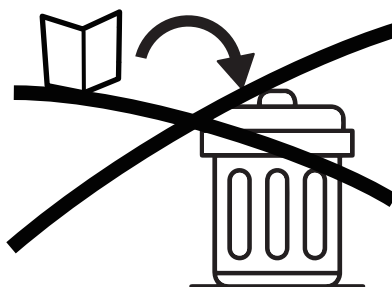
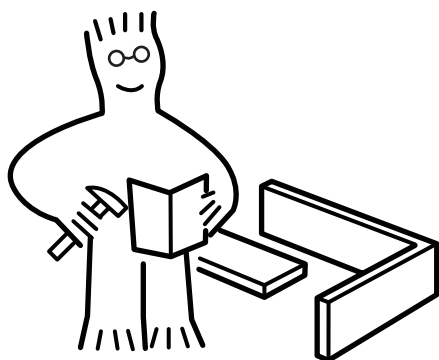

Assemble on a flat, clean and soft surface.

Auf einer flachen, sauberen und weichen Oberfläche zusammenbauen.

Assembler sur une surface plate, propre et douce.

Assemblare su una superficie piatta, pulita e morbida.

Ensamblar sobre una superficie plana, limpia y suave.

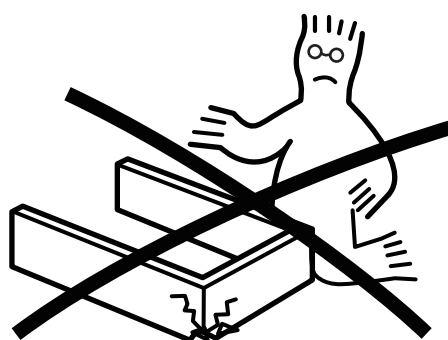
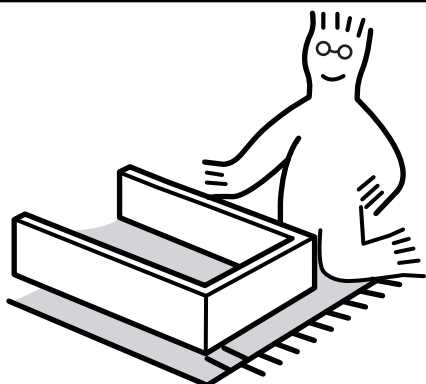

Professional installation is highly recommended.

Eine professionelle Installation wird dringend empfohlen.

Une installation professionnelle est fortement recommandée.

Si raccomanda vivamente l'installazione professionale.

Se recomienda altamente la instalación profesional.



Periodically check that all components are tightly secured.

Überprüfen Sie Regelmäßig, Dass Alle Komponenten Fest Gesichert Sind.

Vérifiez Périodiquement Que Tous Les Composants Sont Bien Fixés.

Controllare Periodicamente Che Tutti I Componenti Siano Ben Fissati.

Verifique Periódicamente Que Todos Los Componentes Estén Bien Asegurados.

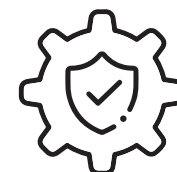

It is recommended that multiple people assemble this product.

Es wird empfohlen, dass mehrere Personen dieses Produkt zusammenbauen.

Il est recommandé que plusieurs personnes assemblent ce produit.

Si raccomanda che più persone assemblino questo prodotto.

Se recomienda que varias personas ensamblen este producto.

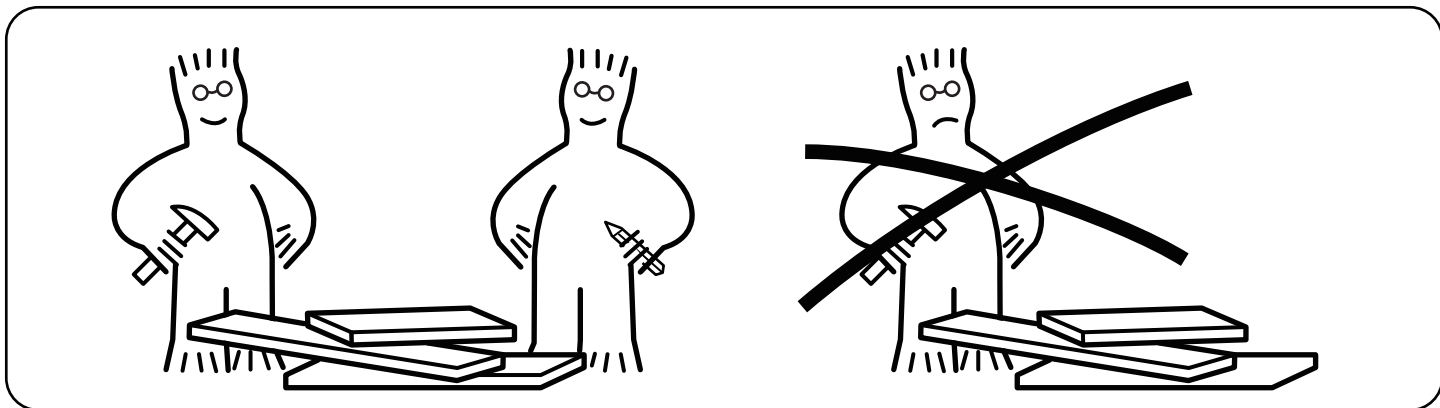

Please have the following auxiliary tools ready:

Bitte halten Sie folgende Hilfswerkzeuge bereit:







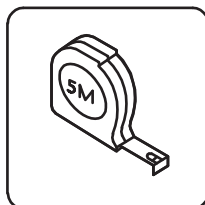
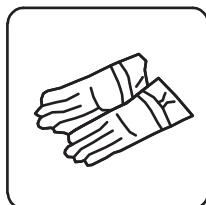
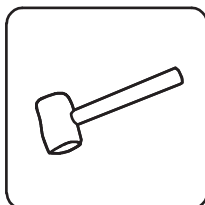
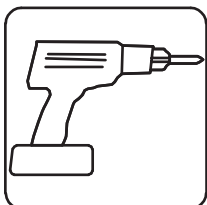

Veillez préparer les outils auxiliaires suivants :

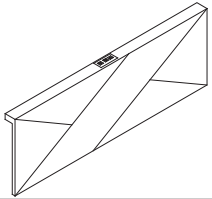
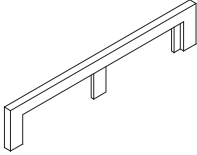

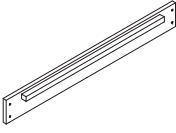
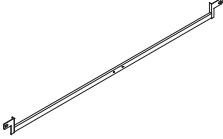
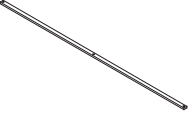
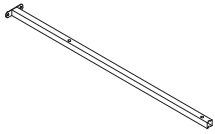
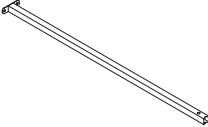

Si prega di avere pronti i seguenti strumenti ausiliari:

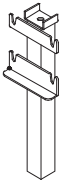
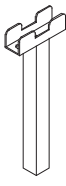
Por favor, tenga listas las siguientes herramientas auxiliares:

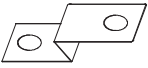
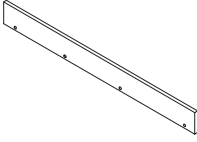
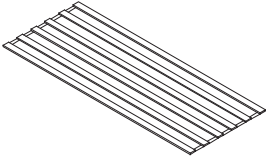
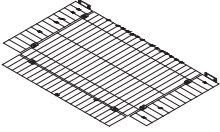

PARTS

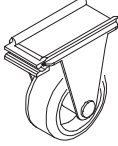
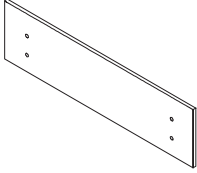
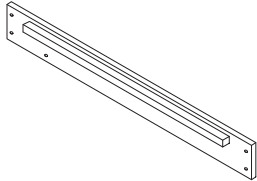
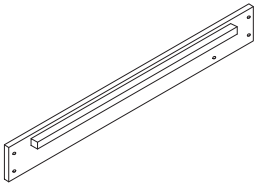
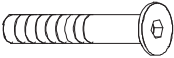
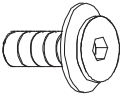
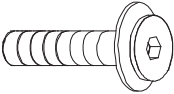
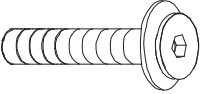
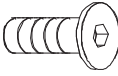
Item no. Nr. N° d'article Articolo No. Artículo No.	Reference Image Referenzbild Image de référence Immagine di riferimento Imagen de referencia	Qty. Menge Qté. Qtà Cant.	Item no. Nr. N° d'article Articolo No. Artículo No.	Reference Image Referenzbild Image de référence Immagine di riferimento Imagen de referencia	Qty. Menge Qté. Qtà Cant.
1		X1	2		X1
3		X2	4		X1
5		X1	6		X2
7		X1	8		X1
9		X1	10		X1
11L		X2	12R		X2
13		X2	14		X2
15		X2	16		X6

Item no. Nr. N° d'article Articolo No. Artículo No.	Reference Image Referenzbild Image de référence Immagine di riferimento Imagen de referencia	Qty. Menge Qté. Qtà Cant.	Item no. Nr. N° d'article Articolo No. Artículo No.	Reference Image Referenzbild Image de référence Immagine di riferimento Imagen de referencia	Qty. Menge Qté. Qtà Cant.
17		X2	18		X1
19		X2	20		X2
21		X4	22		X8
23		X2	24		X1
25		X1	A	 M6X35mm	X4
B	 M8X18mm	X46	C	 M8X35mm	X5
D	 M8X45mm	X5	E	 M6X15mm	X8
F	 M8	X1	G	 ST4X50mm	X2

ASSEMBLY

1

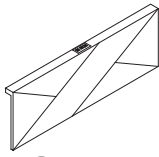

① 1pc



③ 2pcs

M8X45mm

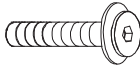

ⓓ 4pcs

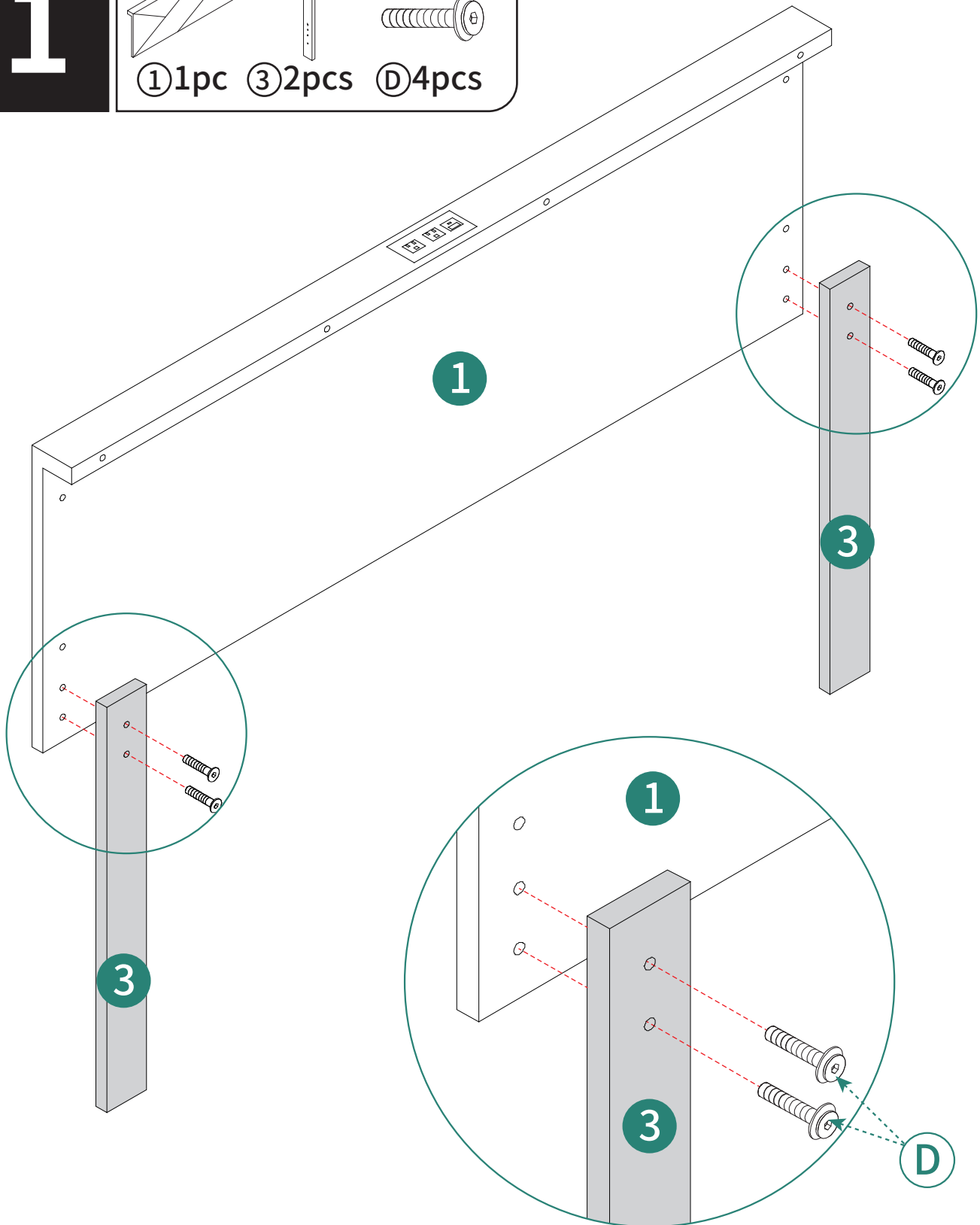

2

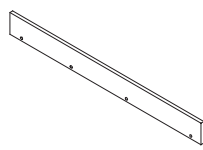

18 1pc



M6X35mm
A 4pcs

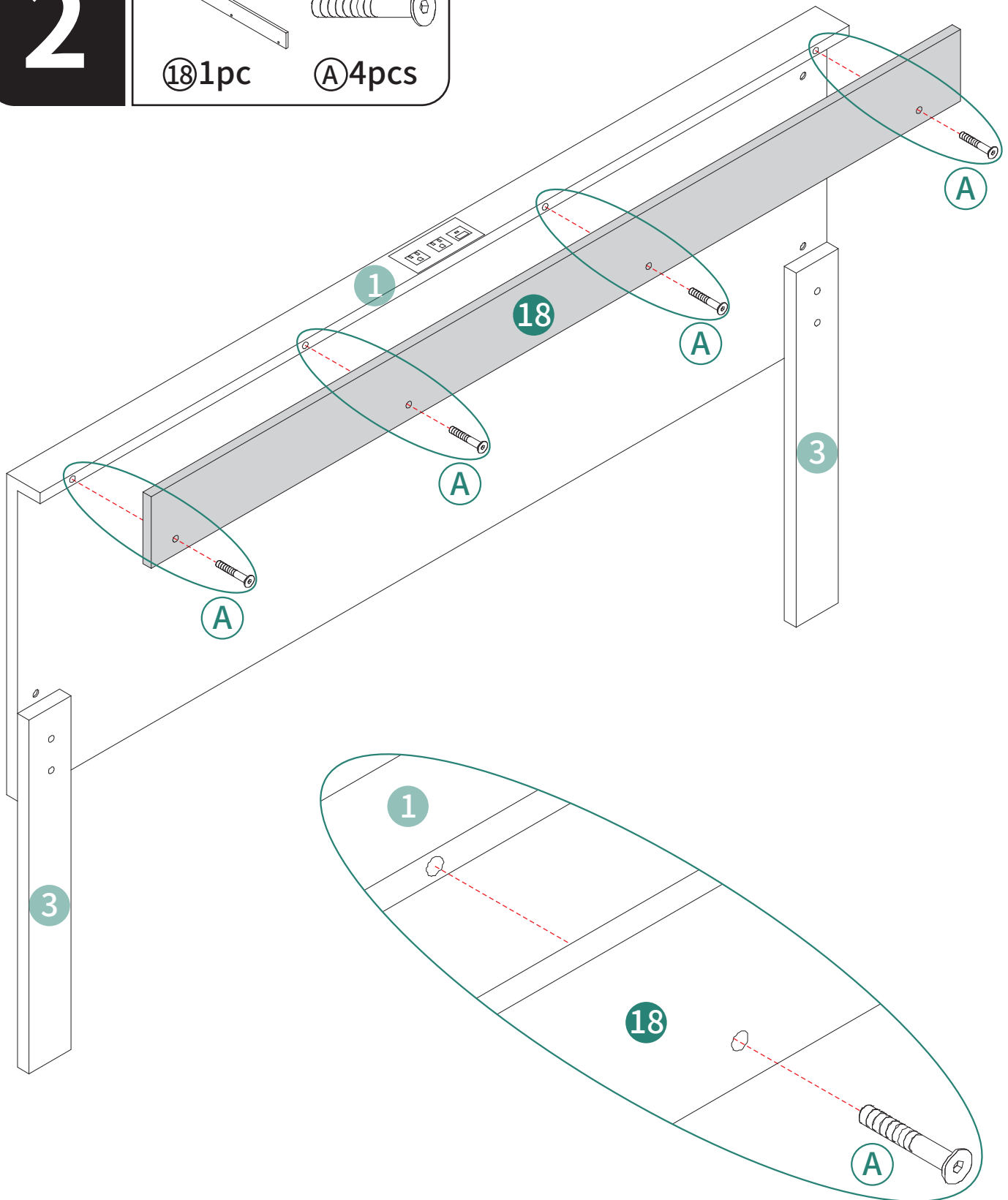

3

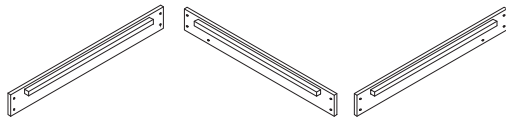

⑥ 2pcs

②④ 1pc

②⑤ 1pc

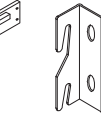

①①L 2pcs



①②R 2pcs



①③ 2pcs

M8X18mm

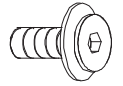

①B 16pcs

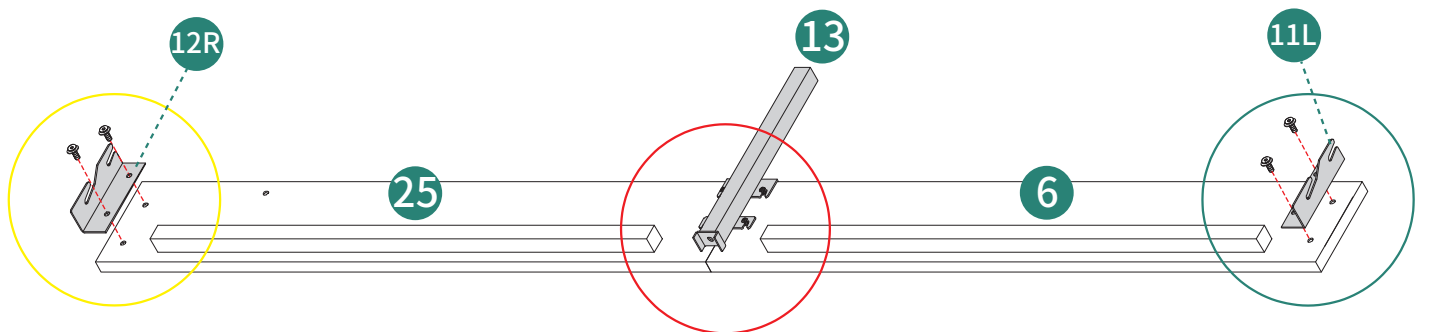
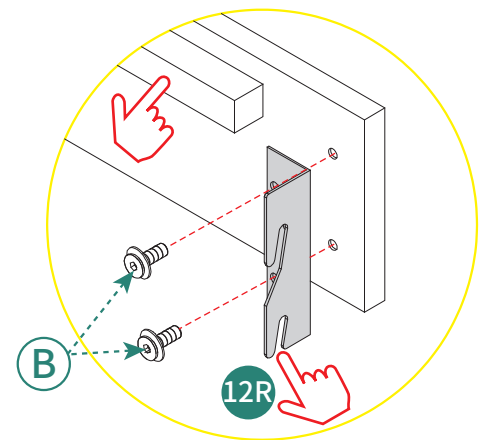
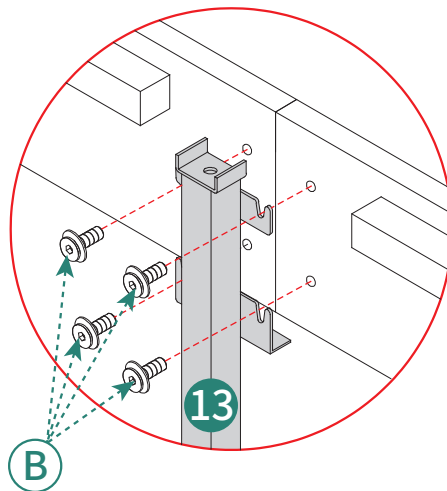
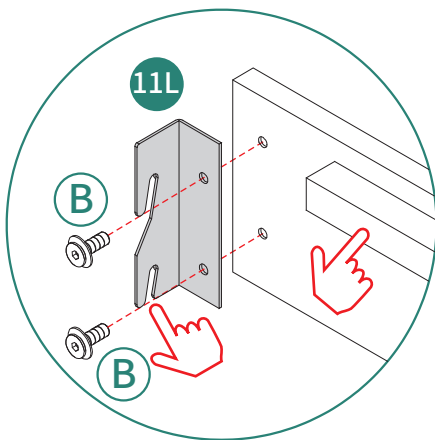
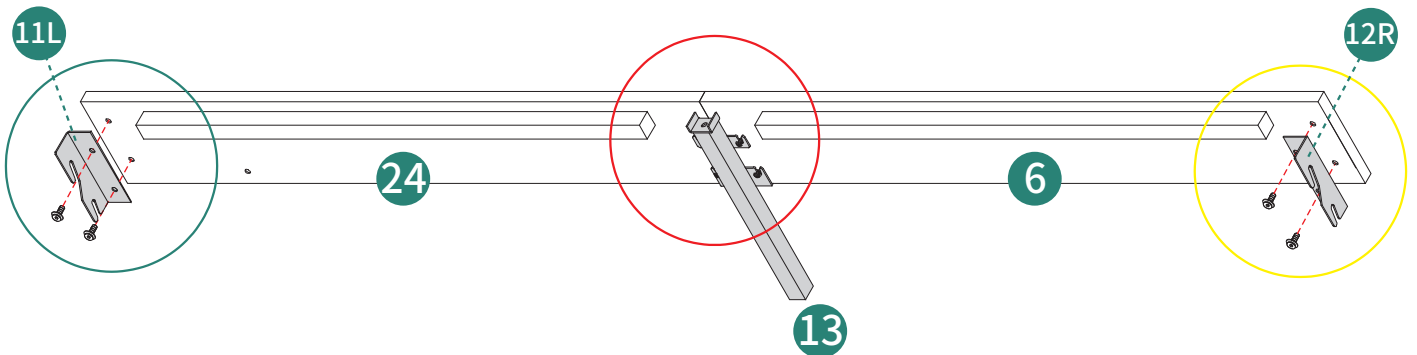

4

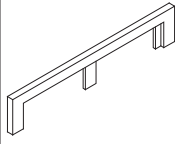

ST4X50mm



②1pc ⑮2pcs ①G2pcs

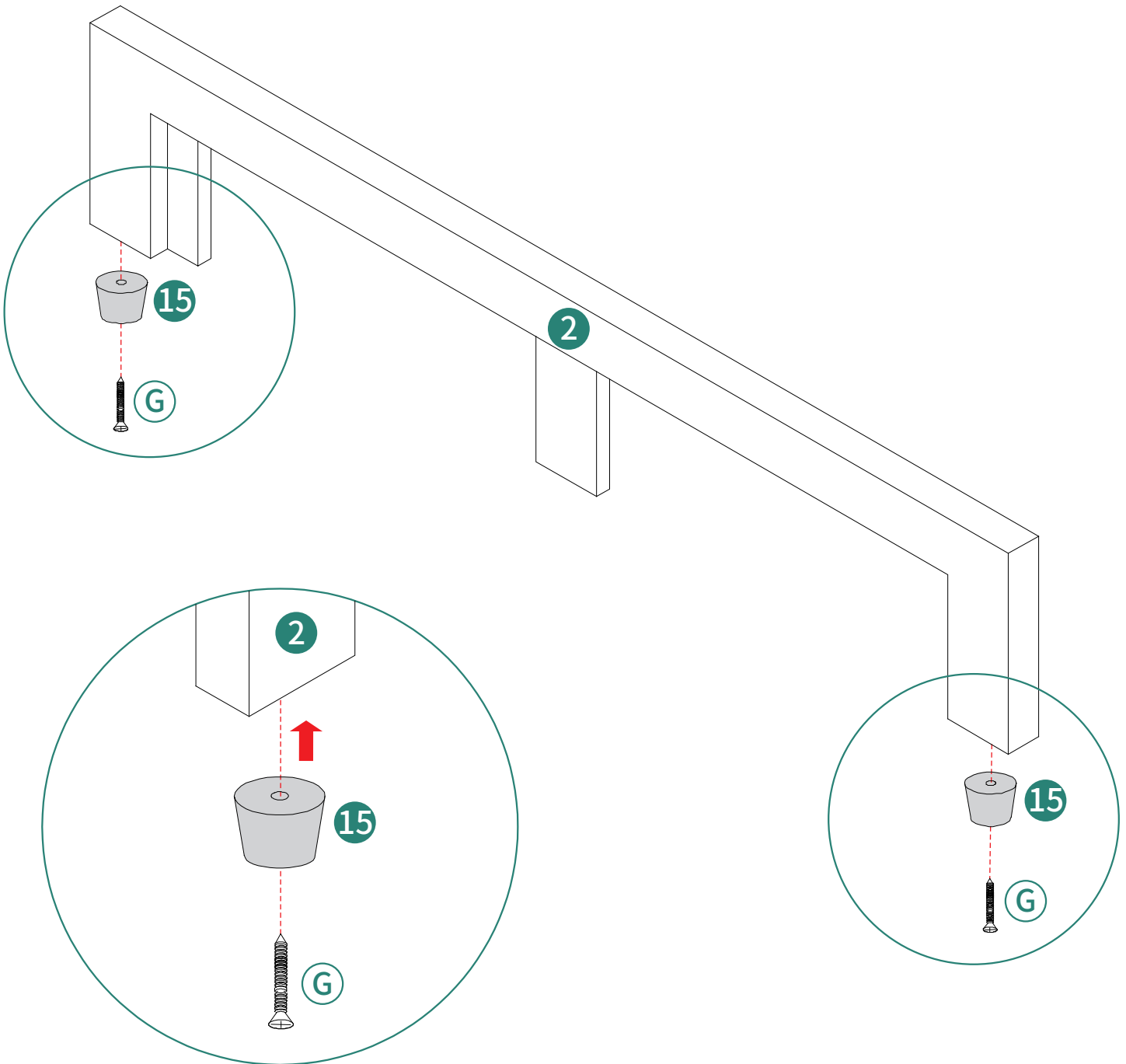

5

M8X18mm

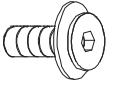

ⓑ 8pcs

Install screws loosely, don't fully tighten.

Schrauben Sie die Schrauben locker an und ziehen Sie sie nicht komplett fest.

Vissez les vis légèrement sans les serrer complètement.

Avvitare le viti allentando un po' senza stringerle completamente.

Apriete los tornillos sueltamente, no los ajuste completamente.

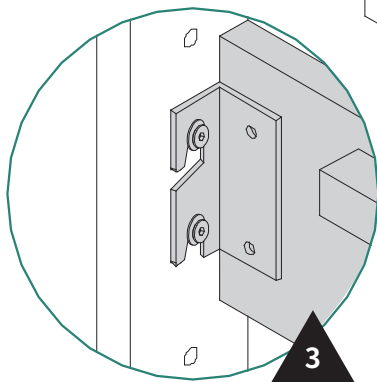
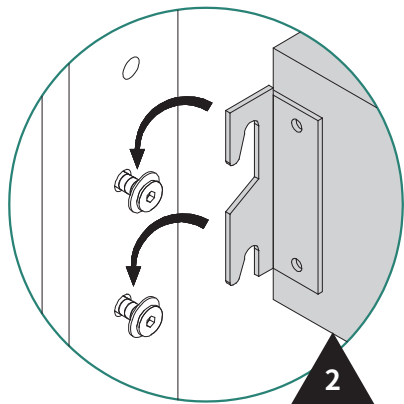
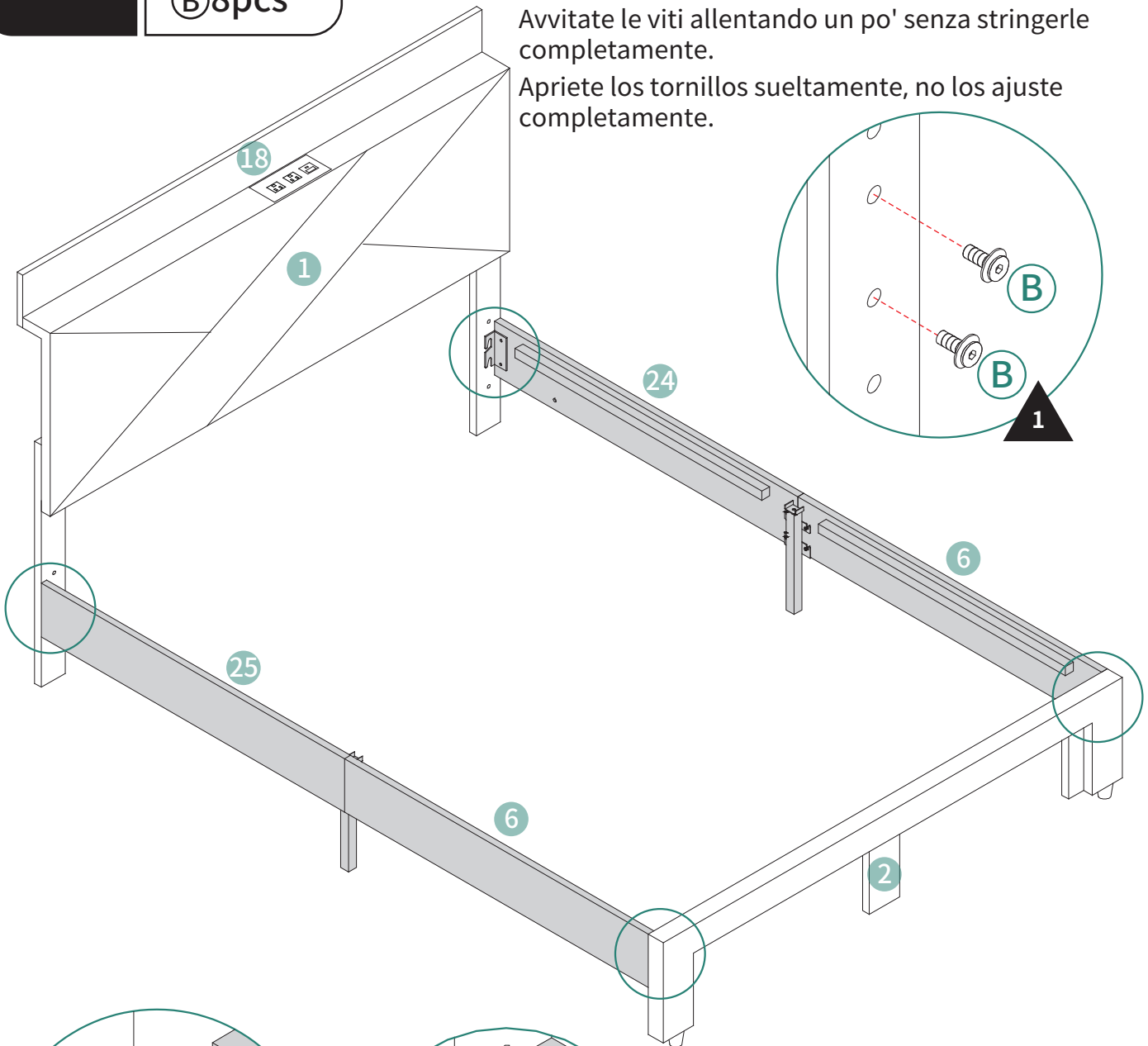

Tighten screws B

Ziehen Sie Schrauben B fest

Serrez les vis B

Stringere le viti B

Ajuste los tornillos B

6

- M8X18mm
- ④ 1pc
 - ⑤ 1pc
 - ①⑥ 4pcs
 - ⑧ 8pcs

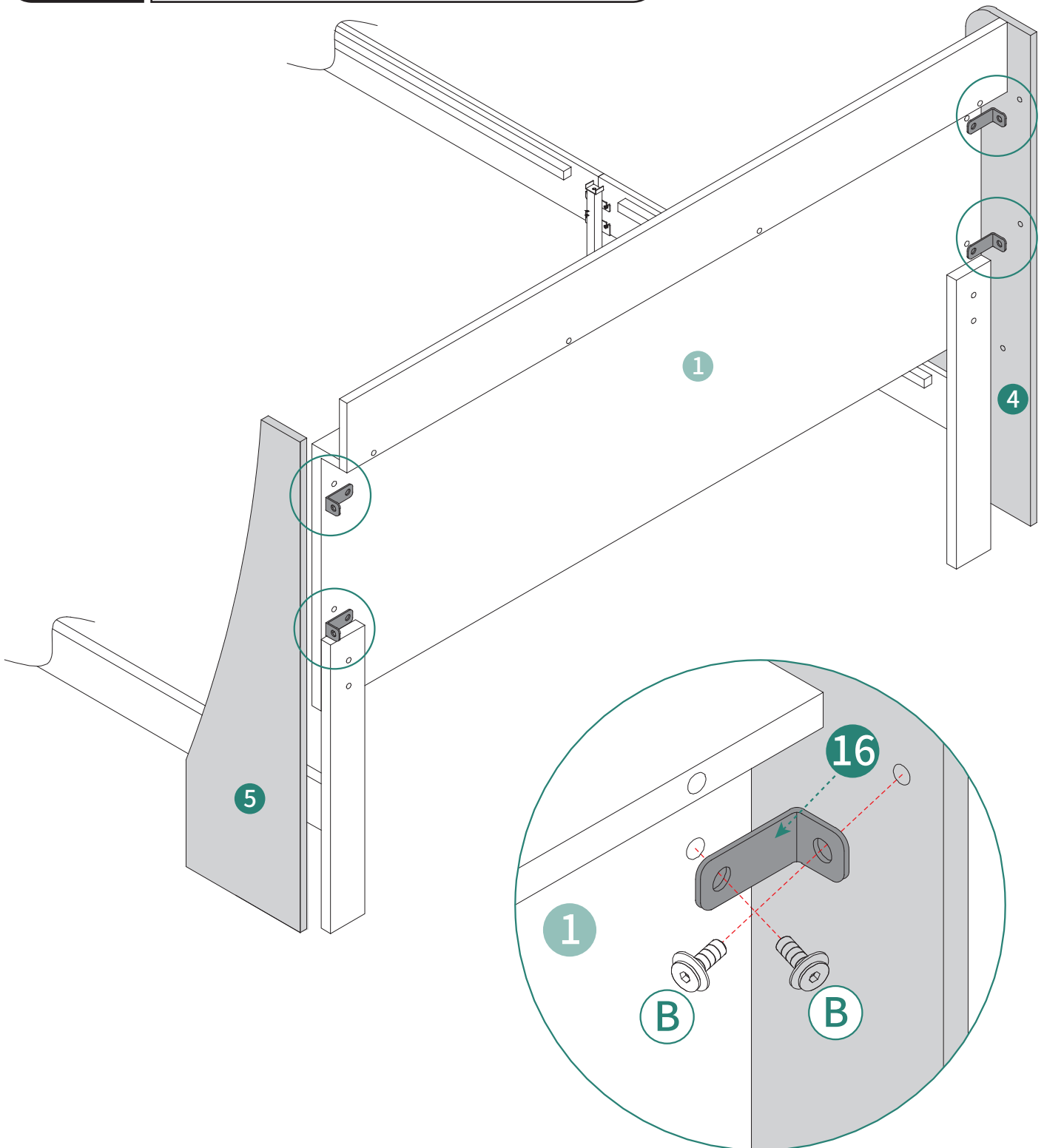

7

M8X18mm

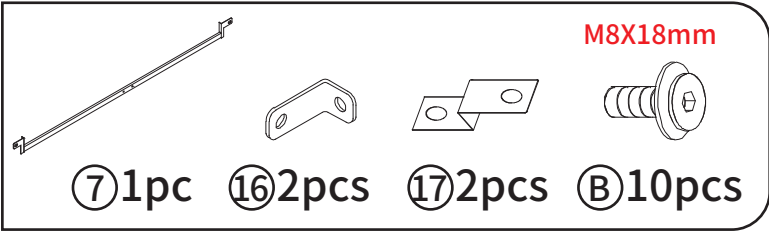

⑦ 1pc ⑩ 2pcs ⑪ 2pcs ⑫ 10pcs

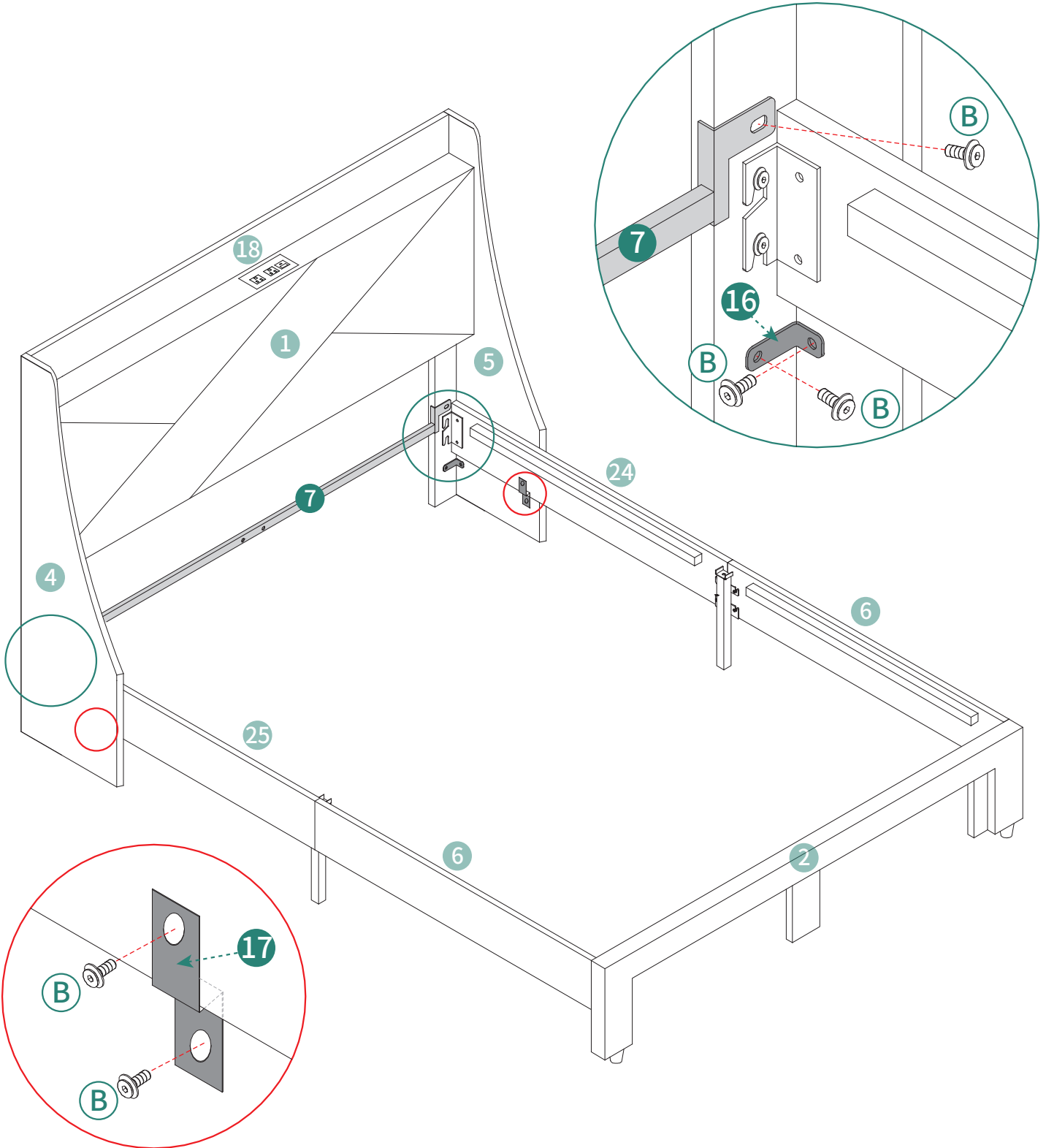

8

M8X35mm

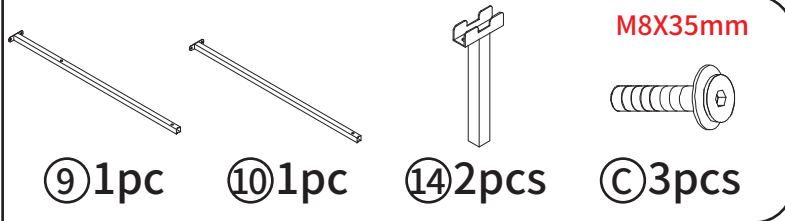

⑨ 1pc ⑩ 1pc ⑭ 2pcs ⑳ 3pcs

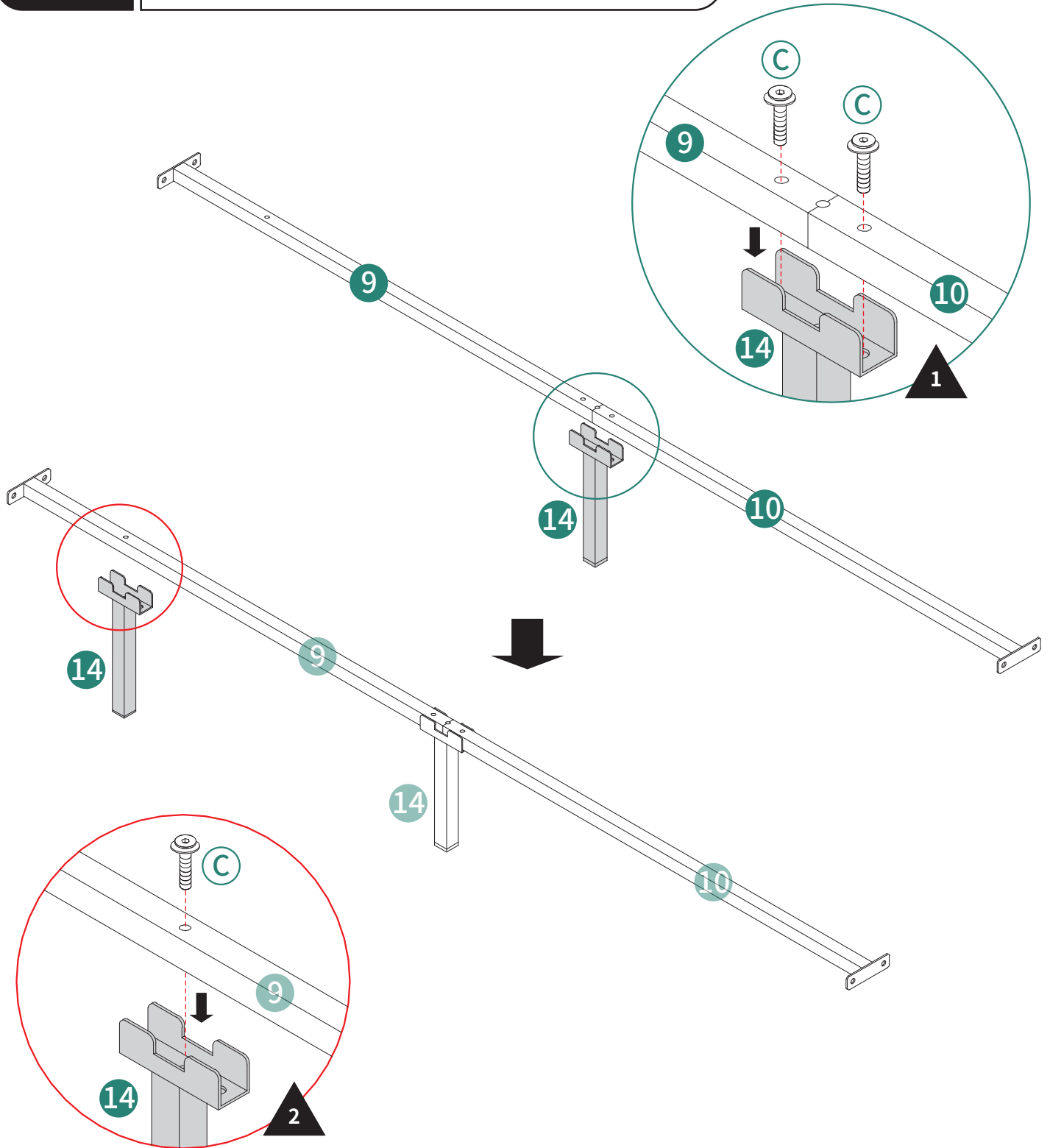

9

M8X18mm

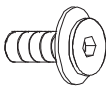

Ⓑ 4pcs

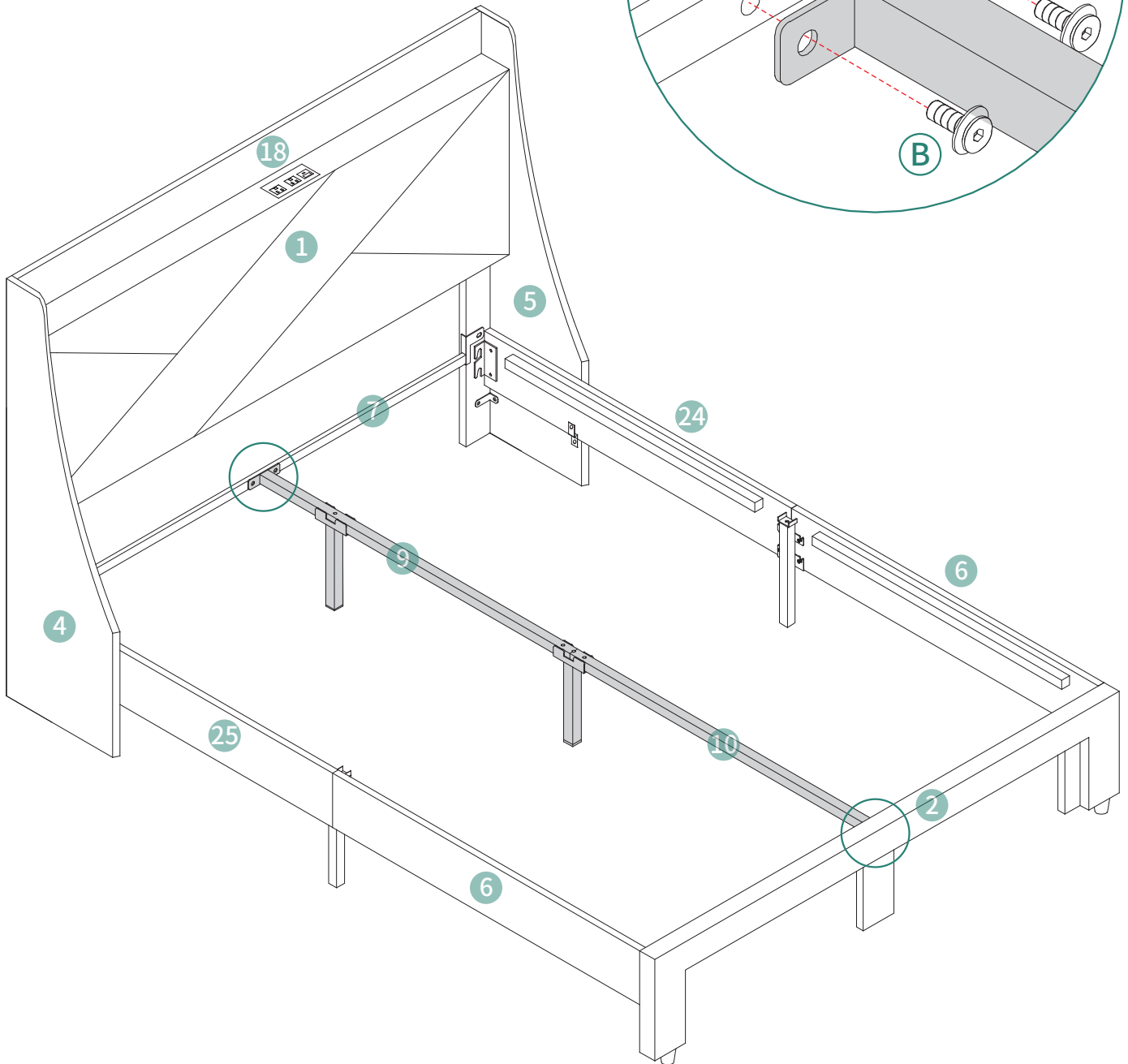
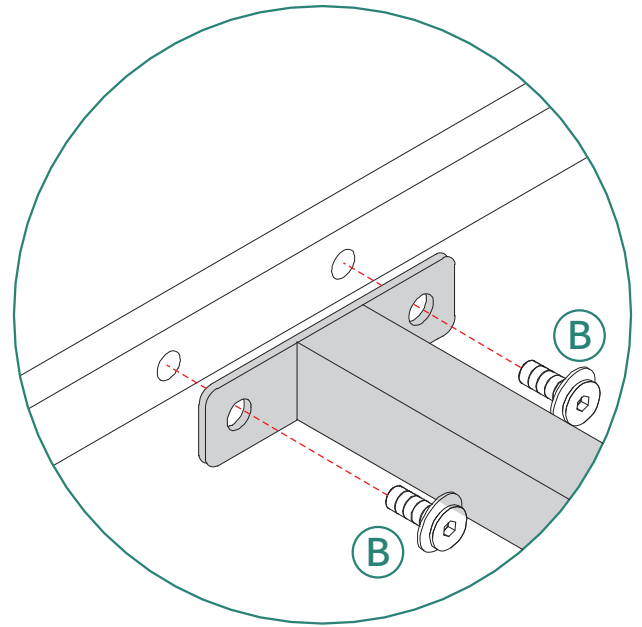

11

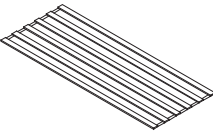

①9 2pcs

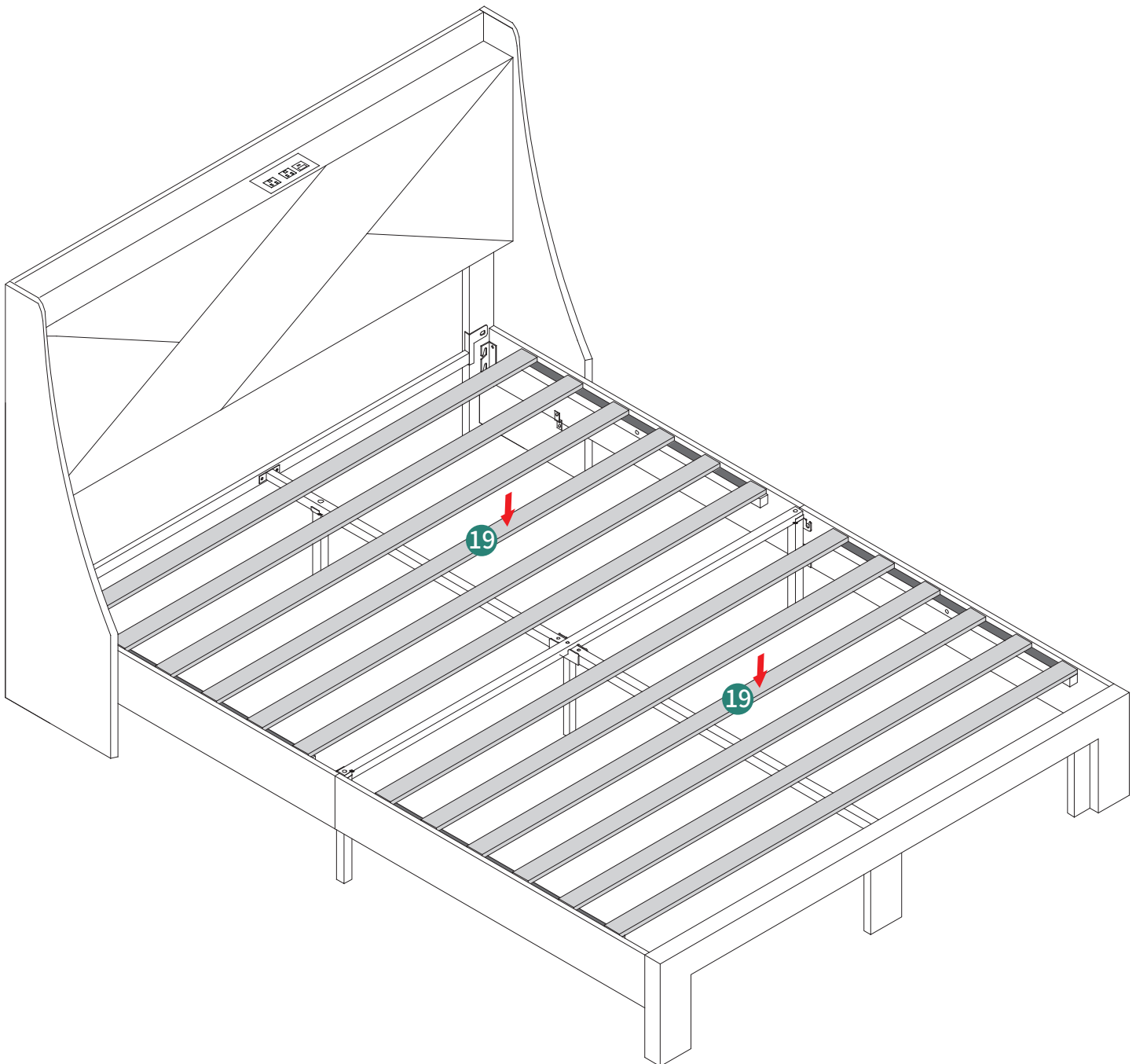

12
X2

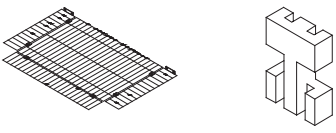

②0 2pcs ②1 4pcs

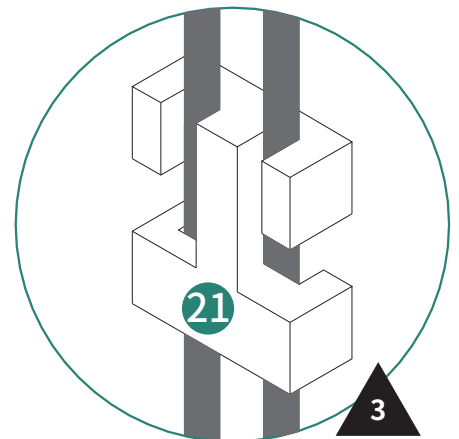
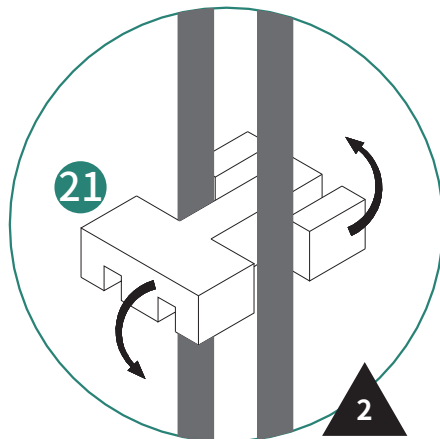
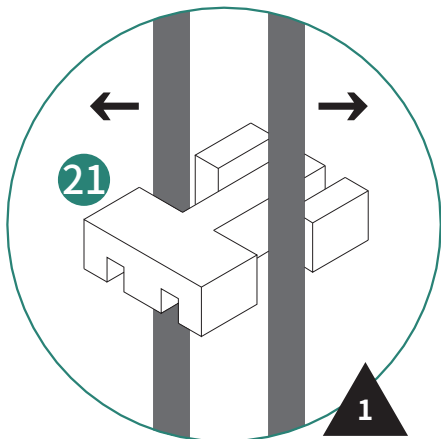
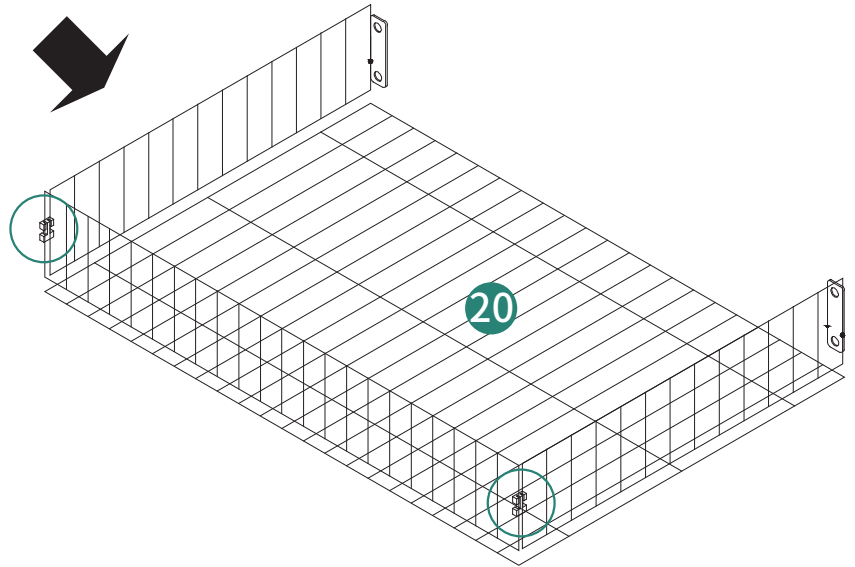
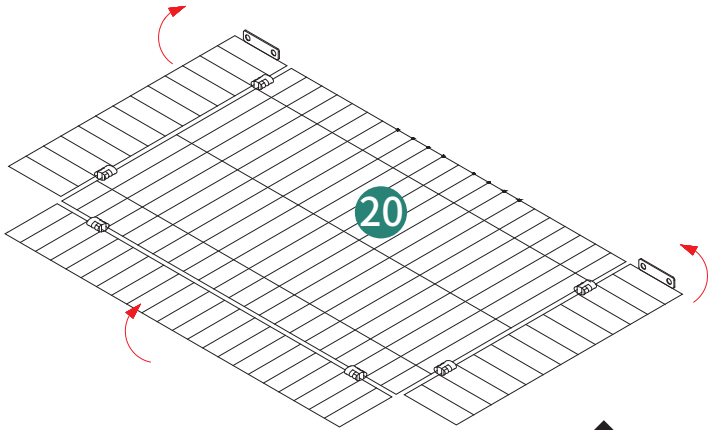

13
X2

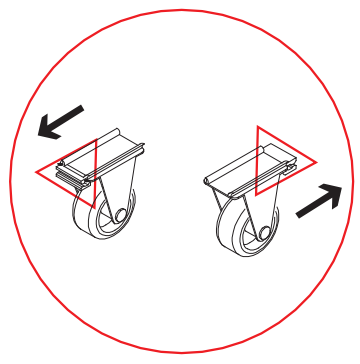
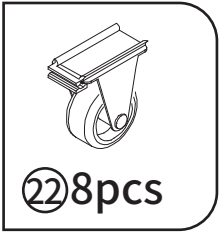

Check the triangular mark for card slot orientation.
Überprüfen Sie die Dreiecksmarkierung für die Orientierung des Kartensteckplatzes.
Vérifiez la marque triangulaire pour l'orientation de la fente de carte.
Verificare la marca triangolare per l'orientamento dello slot per la scheda.
Verifique la marca triangular para la orientación de la ranura de la tarjeta.

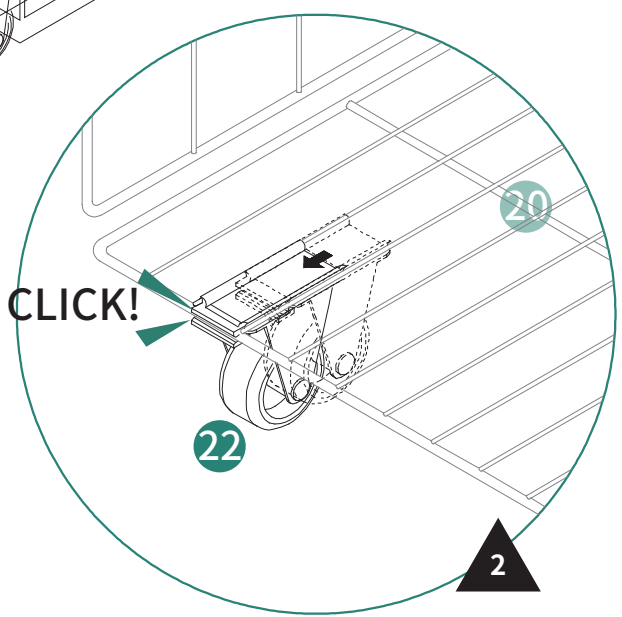
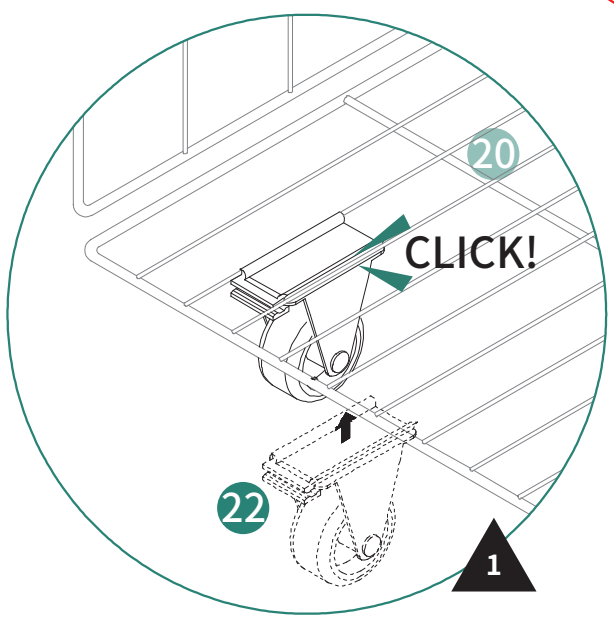
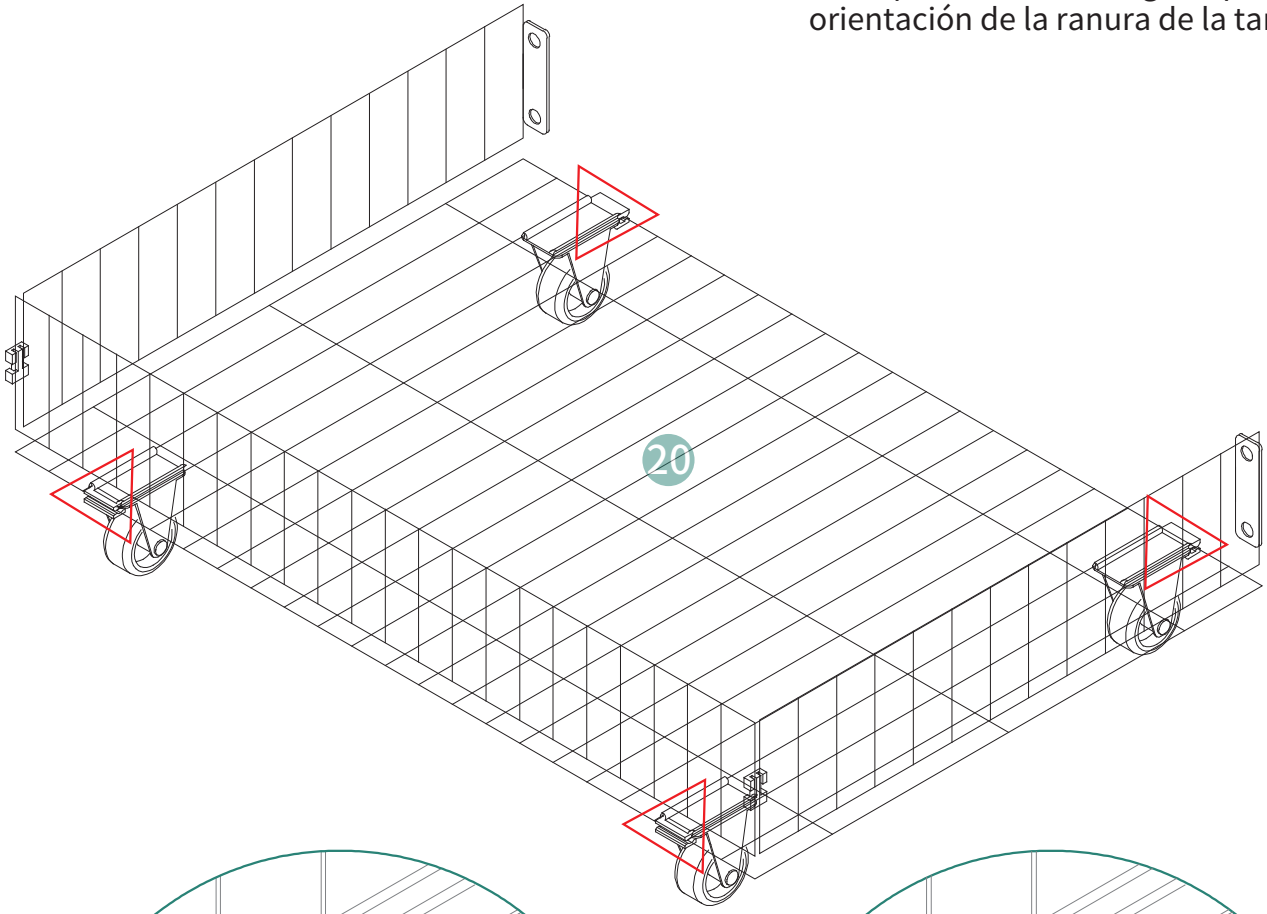

14

X2

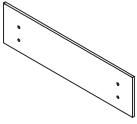

23 2pcs

M8X18mm

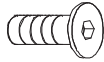

E 8pcs

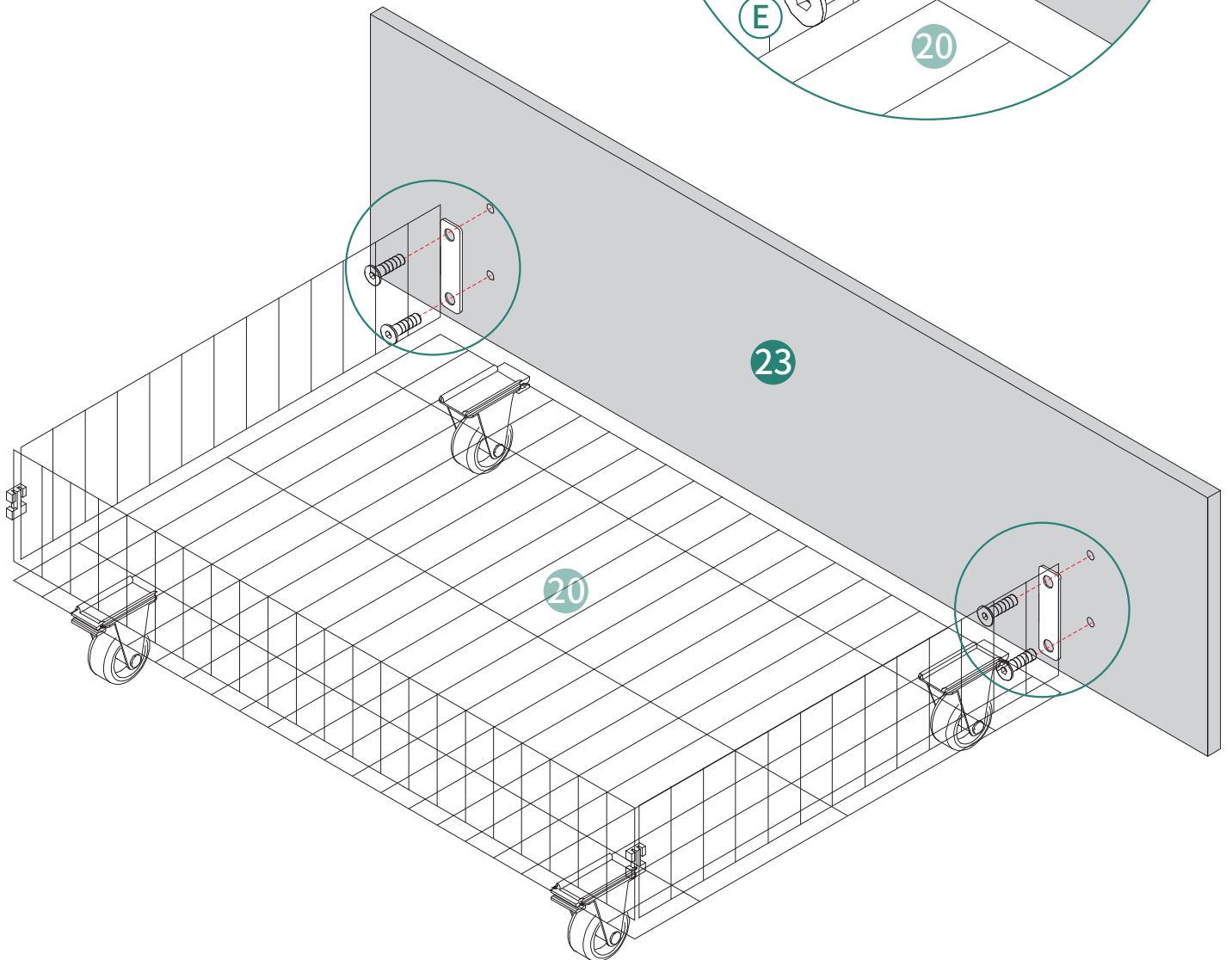
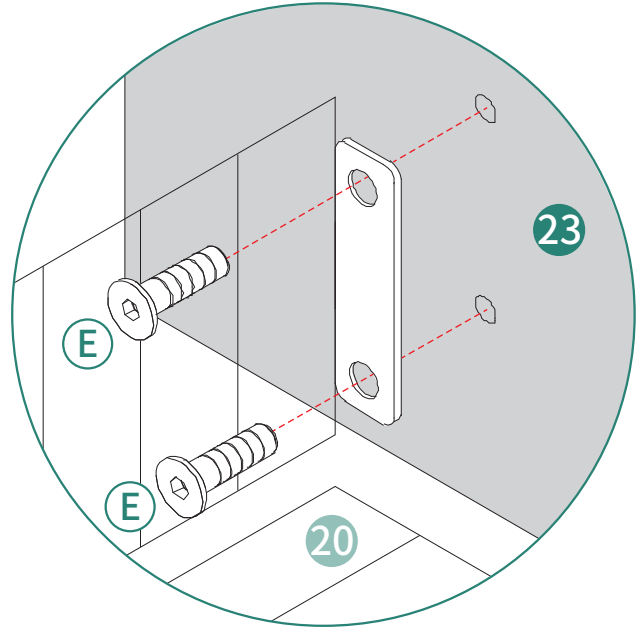

15

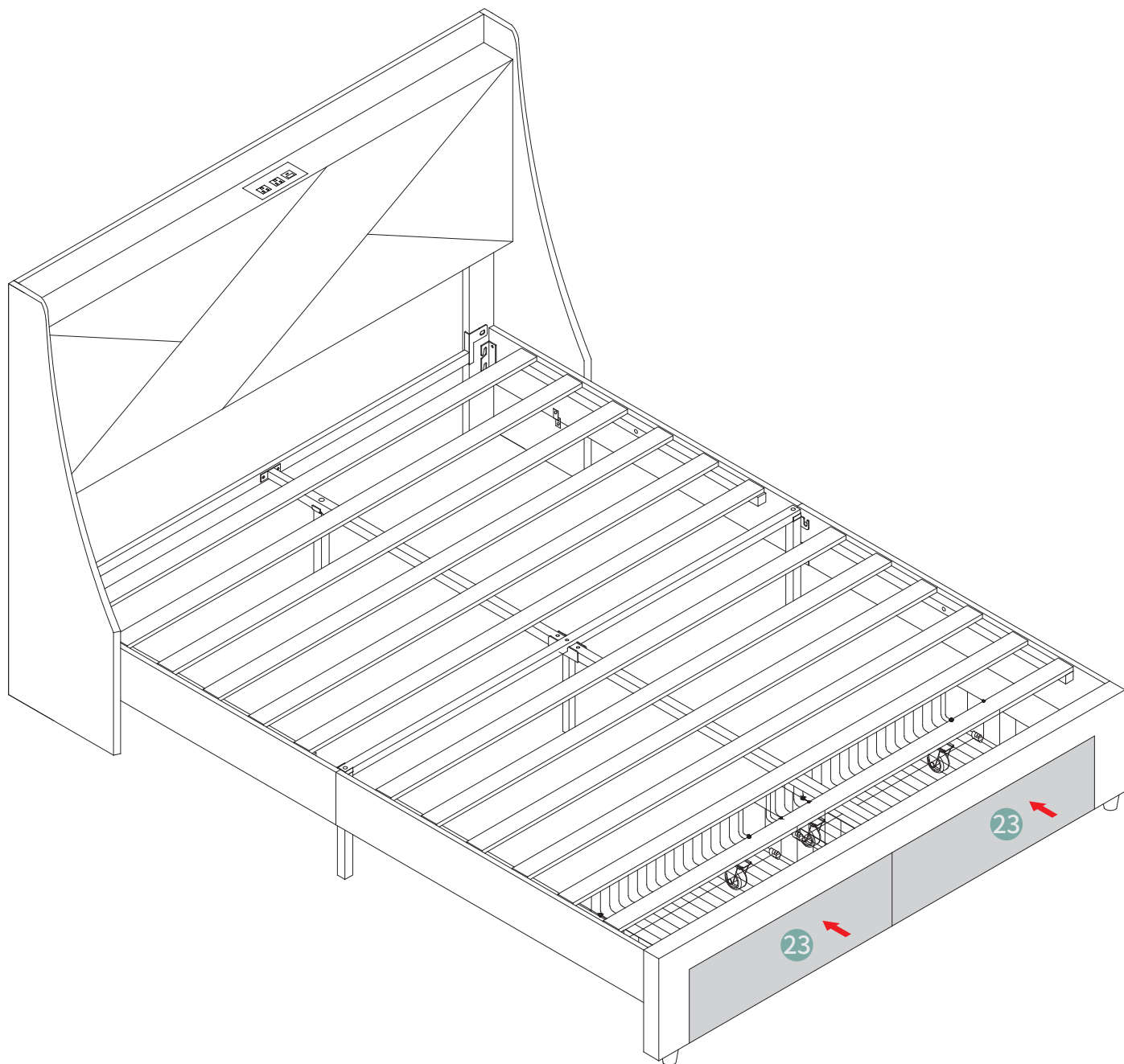

16

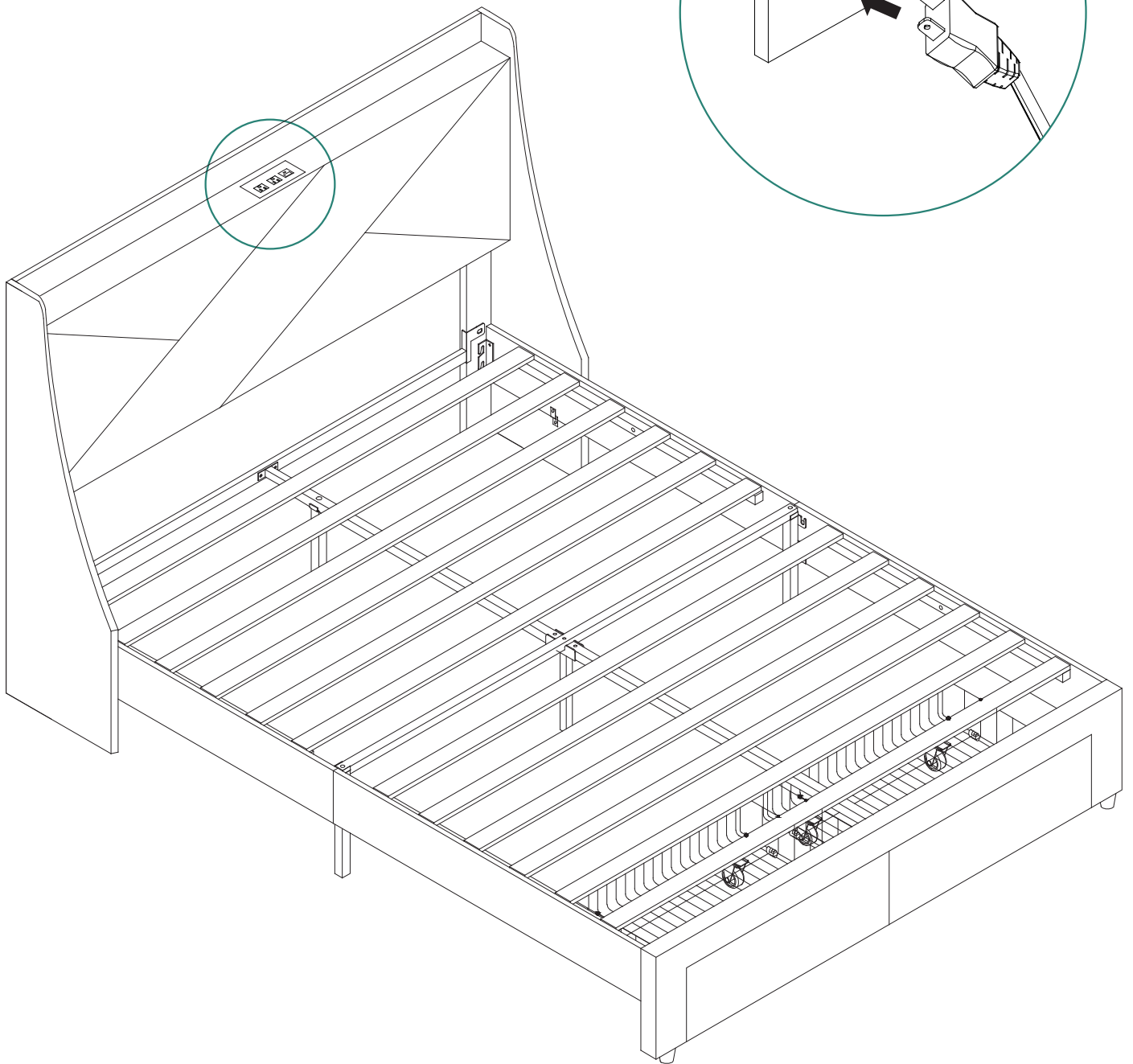

17

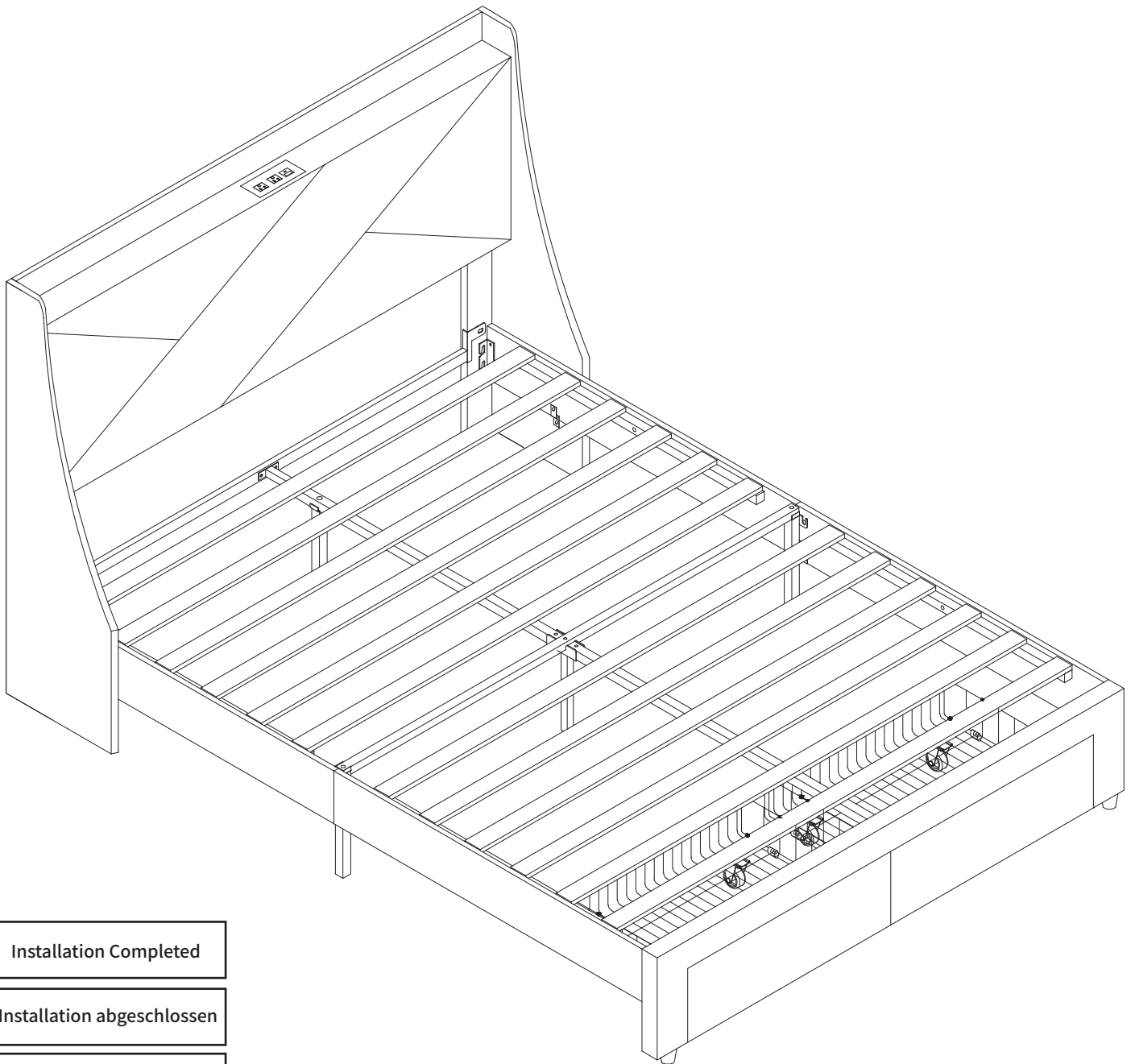

Installation Completed

Installation abgeschlossen

Installation complétée

Installazione completata

Instalación completada

HELP CENTER



Inquiry



Assembly issue



Missing parts

If you encounter any difficulties during assembly, please contact us.

Wenn Sie während der Montage auf Schwierigkeiten stoßen, kontaktieren Sie uns bitte.

Si vous rencontrez des difficultés lors du montage, veuillez nous contacter.

Se incontri difficoltà durante il montaggio, ti preghiamo di contattarci.

Si encuentras alguna dificultad durante el ensamblaje, por favor contáctanos.

DISCLAIMER

Manufacturer and seller expressly disclaim any and all liability for personal injury, property damage or loss, whether direct, indirect, or incidental, resulting from the incorrect attachment, improper use, inadequate maintenance, unapproved modification, or neglect of this product.

Der Hersteller und Verkäufer lehnen ausdrücklich jegliche Haftung für Personenschäden, Sachschäden oder Verluste ab, egal ob direkt, indirekt oder zufällig, die durch falsche Anbringung, unsachgemäßen Gebrauch, unzureichende Wartung, nicht genehmigte Änderungen oder Vernachlässigung dieses Produkts entstehen.

El fabricante y vendedor renuncian expresamente a toda responsabilidad por lesiones personales, daños materiales o pérdidas, ya sean directos, indirectos o incidentales, derivados de la incorrecta colocación, uso inadecuado, mantenimiento insuficiente, modificación no aprobada o negligencia de este producto.

Il produttore e il venditore declinano espressamente ogni responsabilità per lesioni personali, danni materiali o perdite, dirette, indirette o incidentali, derivanti dall'errato fissaggio, uso improprio, manutenzione inadeguata, modifica non autorizzata o negligenza di questo prodotto.

Le fabricant et le vendeur déclinent expressément toute responsabilité en cas de blessures corporelles, de dommages matériels ou de pertes, qu'ils soient directs, indirects ou accessoires, résultant de la fixation incorrecte, de l'utilisation inappropriée, de l'entretien insuffisant, de la modification non approuvée ou de la négligence de ce produit.