







# ASSEMBLY INSTRUCTIONS

## HARDWARE LIST

NO.	SKETCH	DESCRIPTION	QTY
1		Bolt(1/4"x1-7/8")	4 PCS
2		Bolt(1/4"x1-3/8")	2 PCS
3		Spring Washer(1/4")	6 PCS
4		Washer(1/4")	6 PCS
5		Allen wrench(4mm)	1 PC
6		Plastics Cap	2 PCS

## PARTS LIST

NO.	SKETCH	DESCRIPTION	QTY
A		Seat	1 PC
B		Backrest	1 PC
C		Metal frame	1 PC

### Pre-Installation Notes:

1. Please check all parts against the list.
2. Position all components in the correct order as specified.
3. Hand-tighten all screws to 50% torque (do not fully tighten at this stage).
4. Ensure all screw holes are properly aligned before proceeding.
5. Once alignment is confirmed, fully tighten all screws to secure the cushion in place.

### Important Note:

Do not overtighten screws, as this may damage the threads or components.

### Step 1: Seat Installation

Position the cushion holes directly over the corresponding frame holes.

Insert screws in the sequence shown in right.

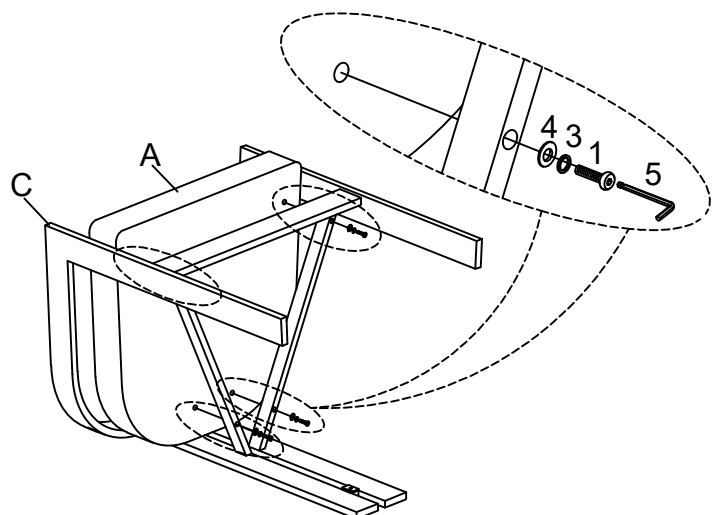

# ASSEMBLY INSTRUCTIONS

## Step 2: Backrest Installation

Insert screws in the sequence shown in right.  
Note the screws used in this step  
is screw 2 ,which shorter then 1.

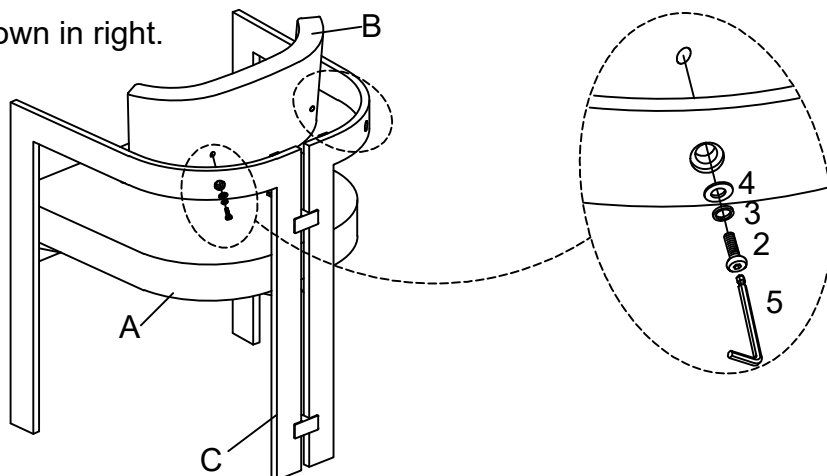

## Step 3: Plastics cap Installation

After completing the installation of  
the step 2, first check if the installation  
is proper, and then install the plastics  
cap.

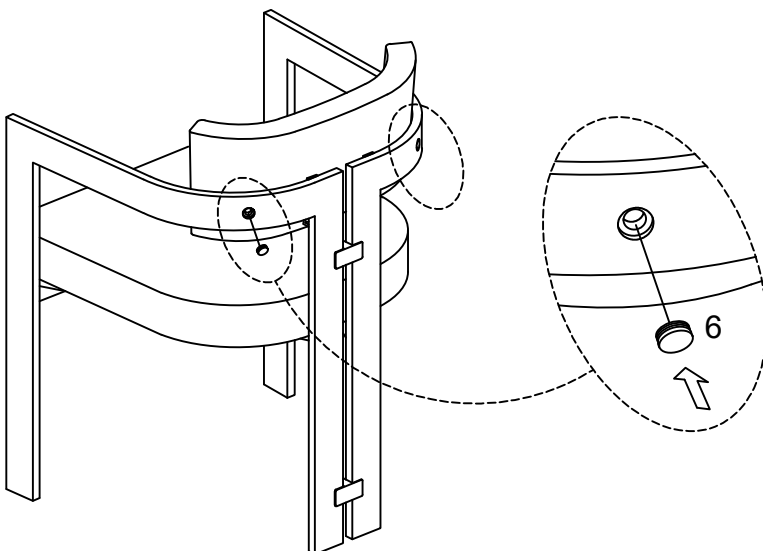

## Step 4: Final Inspection

After it is fully installed, please check if the chair is wobbling,  
unstable or has any defects.

Wishing you a pleasant user experience.

