

# Assembly Instructions

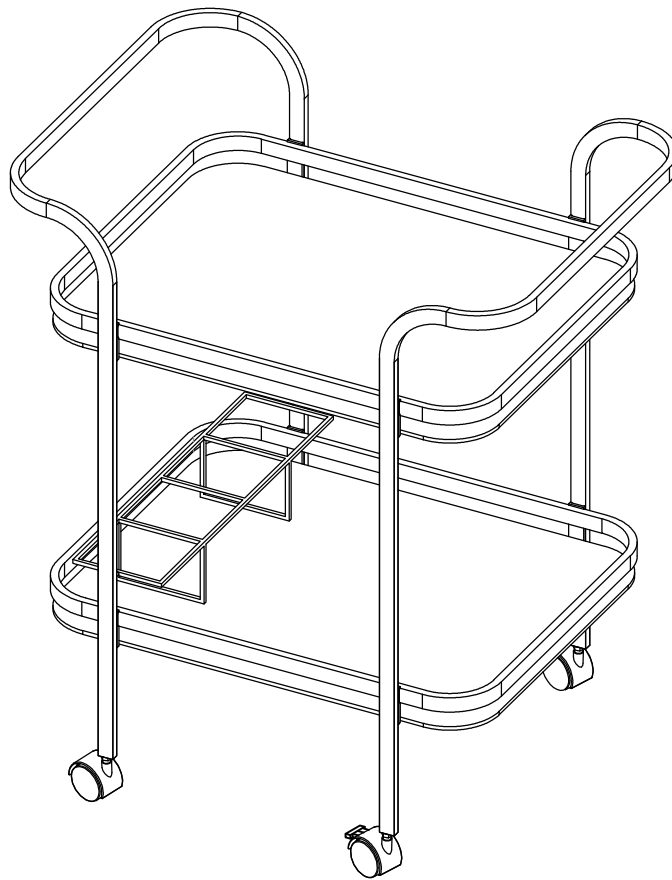

## ASSEMBLY RATING

The Assembly Rating is a 5-point system that shows the degree of effort needed in assembling a specific product (with 1 being easy and 5 being difficult). For some products, two persons are recommended.

EASY  DIFFICULT

## Tools Required For Assembly:

Allen Wrench

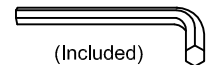

Wrench

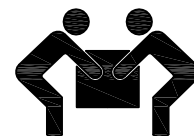

2 PERSONS RECOMMENDED

# ASSEMBLY & CARE ADVICE

FOR YOUR FURNITURE TO LAST, CORRECT ASSEMBLY AND PROPER MAINTENANCE ARE NECESSARY. PLEASE FOLLOW THE INFORMATION PROVIDED BELOW TO FULLY ENJOY YOUR FURNITURE.

## BASIC ASSEMBLY TECHNIQUES



When lock or spring washer is used in an assembly, please make sure the lock or spring washer is placed between the larger flat washer and the head of the screw or bolt.



Position each part correctly and insert screws or bolts into their respective holes by hand tighten or using the proper hand tool. Only tighten when step is completed or when instructed to do so.



Use cardboard or carpet area when assembling furniture to prevent scratches. Make sure the furniture rests on a flat and level surface with each leg evenly touching the floor.



Some furniture comes with height adjustment knobs underneath each leg. To lower or to raise each leg, you need to turn clockwise or counterclockwise, respectively.



Make sure all parts are properly aligned, then use the appropriate hand tool to completely tighten the bolts or screws. Do not use power tools and do not overtighten.



Save the instructions and store the Allen wrench or any supplied tool for later maintenance. After two weeks, check and tighten any loose hardware and repeat again every six months thereafter.

IT IS THE USER'S RESPONSIBILITY TO MAINTAIN THE FURNITURE. THE HARDWARE MAY LOOSEN OVER TIME AND MAY CAUSE THE FURNITURE TO BE WOBBLY AND UNABLE TO SUPPORT ITS INTENDED WEIGHT CAPACITY. THIS MAY LEAD TO COLLAPSE AND MAY CAUSE SERIOUS INJURY.

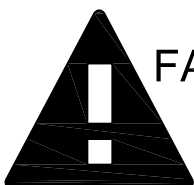

**FAILURE TO FOLLOW THE GUIDELINES ABOVE MAY RESULT IN INJURY AND/OR PROPERTY DAMAGE.**

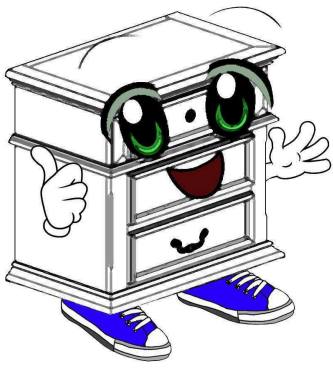

Before you begin, please read Page 2 of "Assembly and Care Advice".

And remember, do not tighten until each step is completed or instructed.

### Parts List

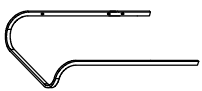

#1 x 1pc  
Left Panel

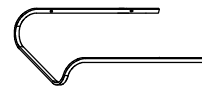

#2 x 1pc  
Right Panel

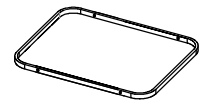

#3 x 2pcs  
Metal Frame



#4 x 1pc  
Wine Frame



#5 x 2pcs  
Mirror

### Hardware List

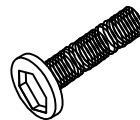

#A x 8pcs  
Bolt 15mm



#B x 8pcs  
Metal Chip



#C x 8pcs  
Suction Cup



#D x 4pcs  
End Cap

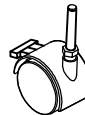

#E x 2pcs  
Caster w/ Brake



#F x 2pcs  
Caster w/o Brake



#G x 1pc  
Allen Wrench

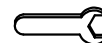

#H x 1pc  
Wrench



Insert each end of the wine frame (#4) into the slots along the left panel (#1).

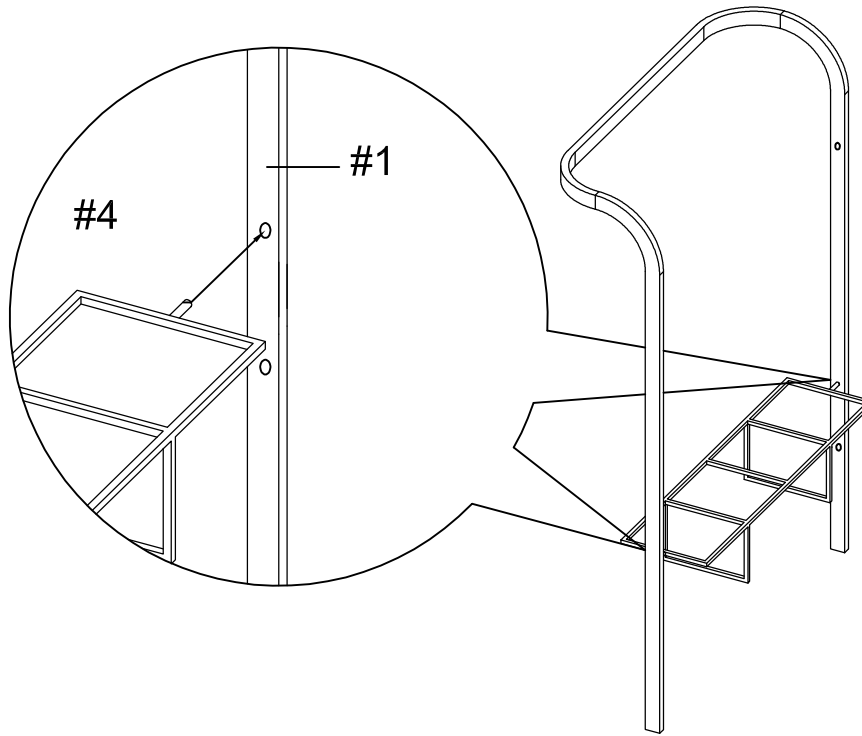

#A X 8PCS  
#B X 8PCS

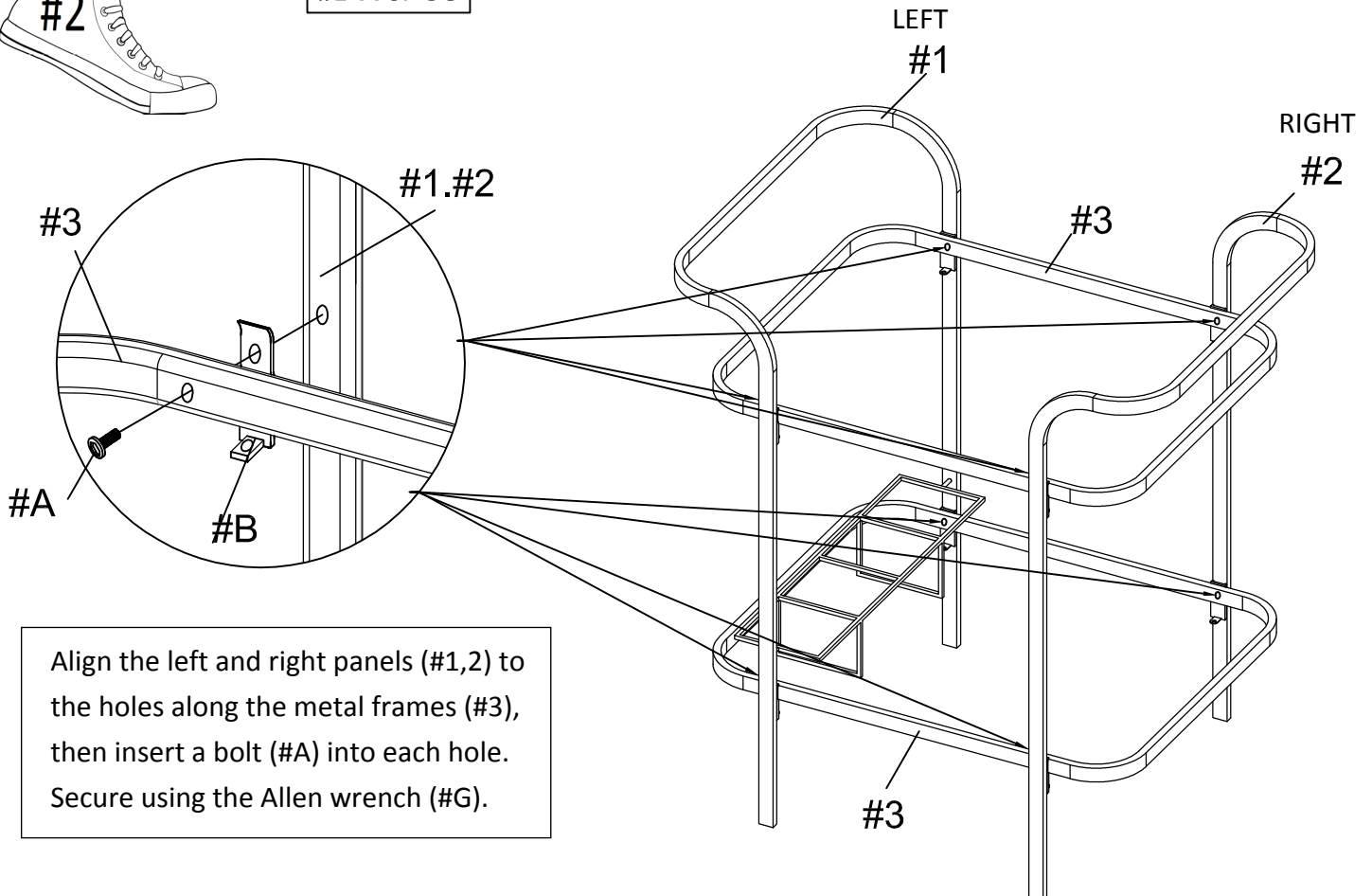

Align the left and right panels (#1,2) to the holes along the metal frames (#3), then insert a bolt (#A) into each hole. Secure using the Allen wrench (#G).



#3

#C X 8PCS  
#D X 4PCS  
#E X 2PCS  
#F X 2PCS

1. Insert the suction cups (#C) into the slots along the left and right panels (#1,2).

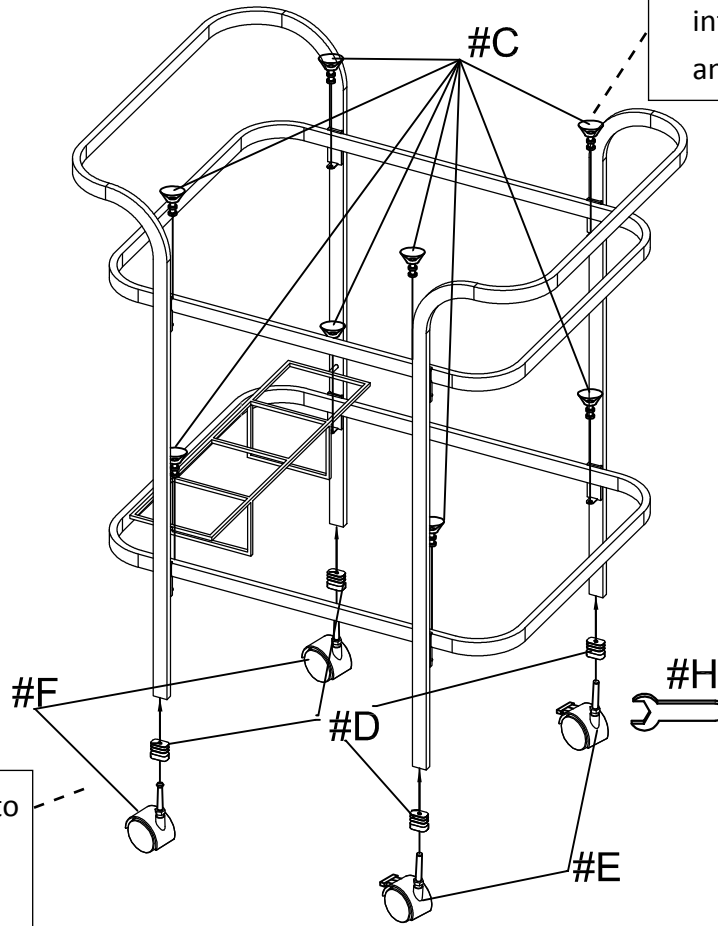

2. Insert an end cap (#D) into each end, then insert a caster (#F) into each cap.



#4

Place the mirrors (#5) onto the suction cups (#C).

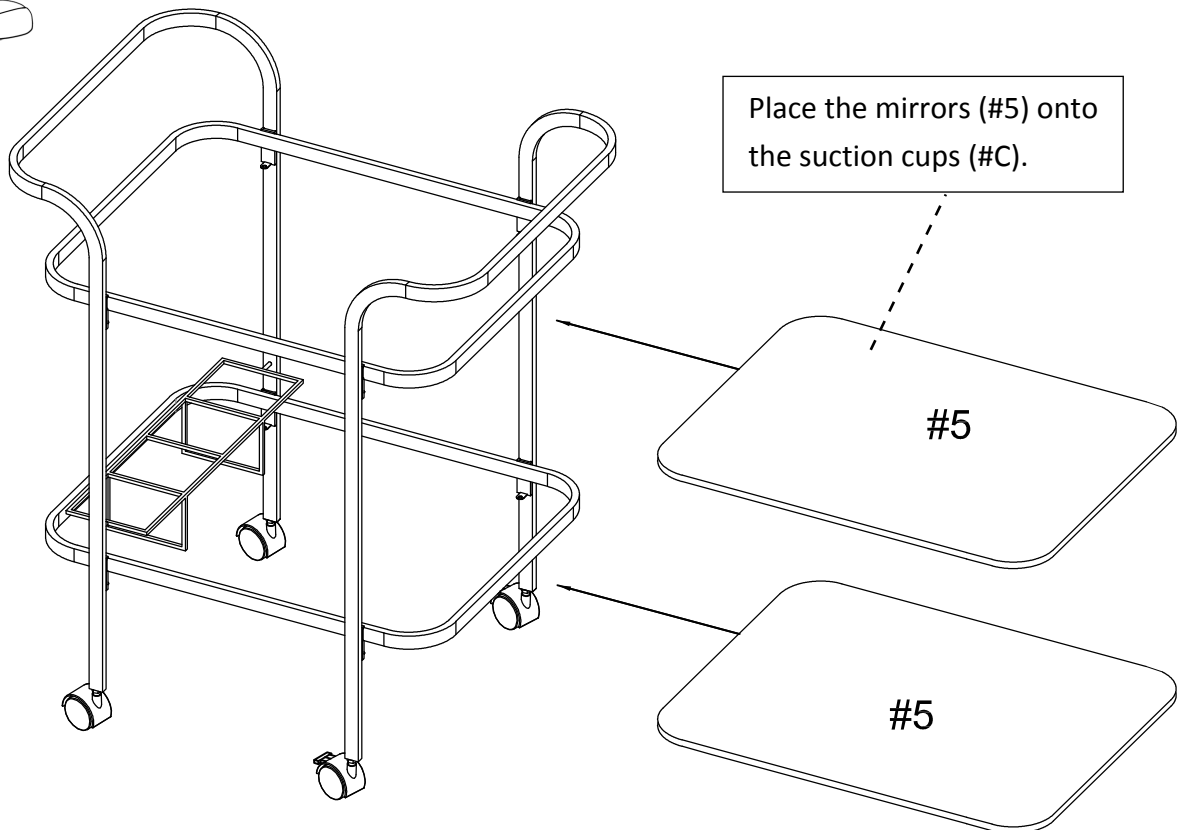

ASSEMBLY IS COMPLETED