

PRODUCT CARE HANDBOOK

a guide to protect your product

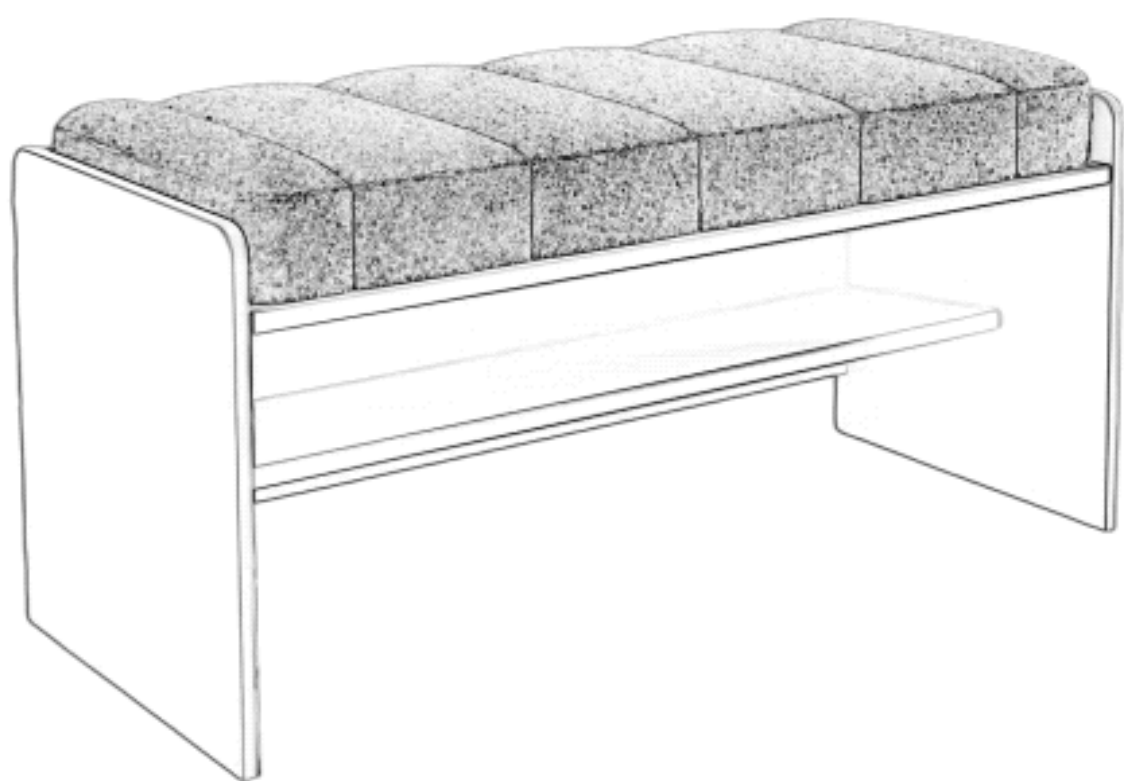

Thank you for purchasing this product. Please read these instructions fully before starting assembly, then follow the simple step by step guide.

TOP TIPS BEFORE YOU START!

1. Please check that all parts & hardware are present before you start the assembly of your furniture. Do not destroy any of the packaging until your are certain that you have all thenecessary parts for assembly.
2. To ensure a smooth installation , we recommend that before you commence each step of the assembly, please identify all the parts required for that step.
3. We recommend that where possible, all items are assembled near to the area in which the will be placed in use, to avoid moving the product unnecessarily once assembled.
4. For the protection of your furniture, particularly items of high gloss finish, we recommend that the product is placed on a protected surface during assembly to prevent any damage.
5. During assembly, please take care not to over-tighten any fittings, as this may damage the product.
6. Keep children and animals away from the work area. Small parts could cause choking if swallowed.

Rubber Hammer

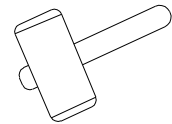

Tools Required For Assembly

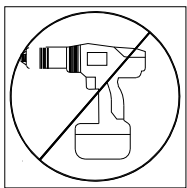

DO NOT USE POWER TOOLS TO ASSEMBLE THIS PRODUCT. USE OF POWER TOOLS WILL INVALIDATE ANY CLAIM AND MAY DAMAGE THIS PRODUCT MAKING IT UNSAFE.

Tape Measure

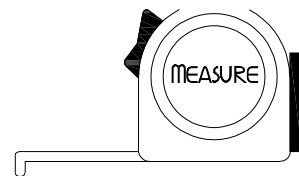

Self-provided universal tool diagram :

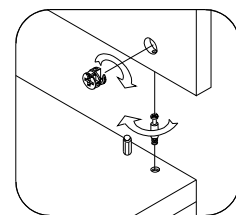
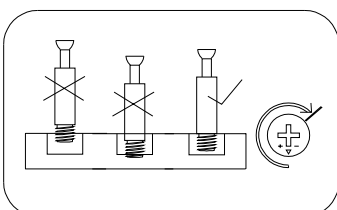

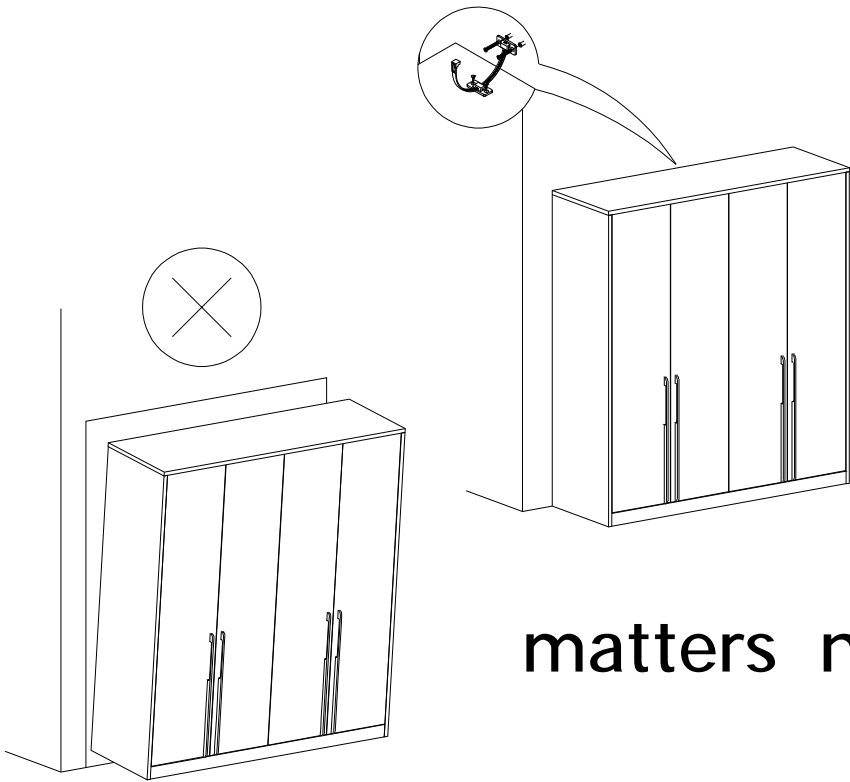



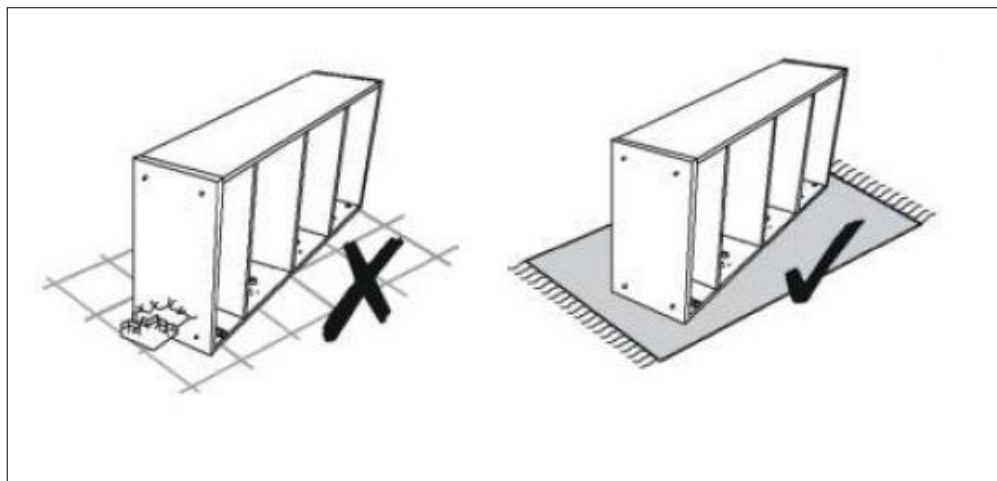
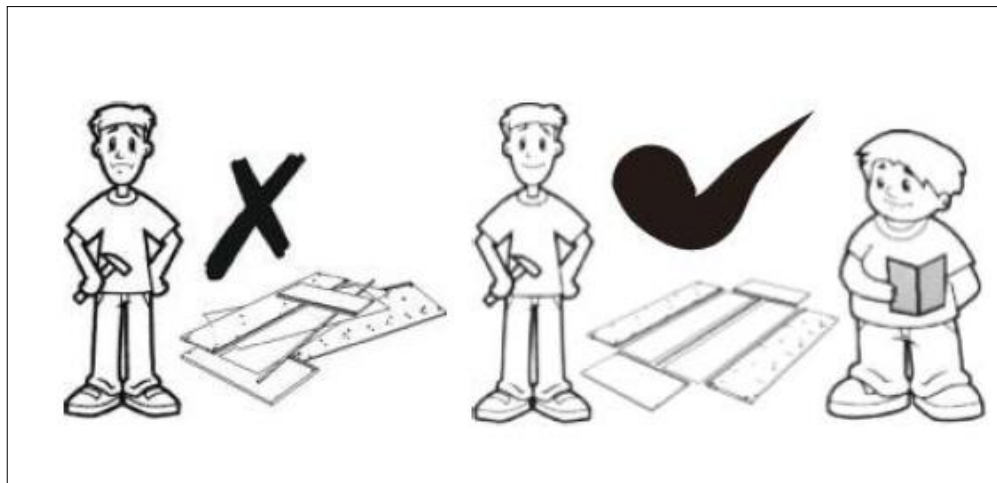

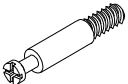

matters needing attention

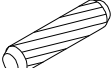

Shoe Bench Assembly Hardware

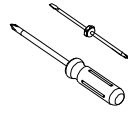
<p>H1101(A)</p>  <p>3-in-1 Connector Rod Φ6*40</p> <p>18PCS</p>	<p>H1201(B)</p>  <p>3-in-1 Eccentric Fitting Φ14.5*11.5</p> <p>18PCS</p>	<p>H1118(C)</p>  <p>Wood Dowel Φ 8 * 30</p> <p>8PCS</p>	<p>HA00122(D)</p>  <p>Pan Head Self-Tapping Screw M3.5 * 14</p> <p>8PCS</p>	<p>HS0025 (E)</p>  <p>Plum Blossom Angle Code 20*20</p> <p>4PC</p>
<p>HK0116(F)</p>  <p>Masking Tape Φ 20</p> <p>18PCS</p>	<p>HV0003(G)</p>  <p>Double-Ended Screwdriver</p> <p>1PC</p>			

Shoe Bench Assembly Hardware

B01*1 Seat Panel	B03*1 Partition	B05*1 Back Panel
B02*1 Left Side Panel	B04*1 Right Side Panel	

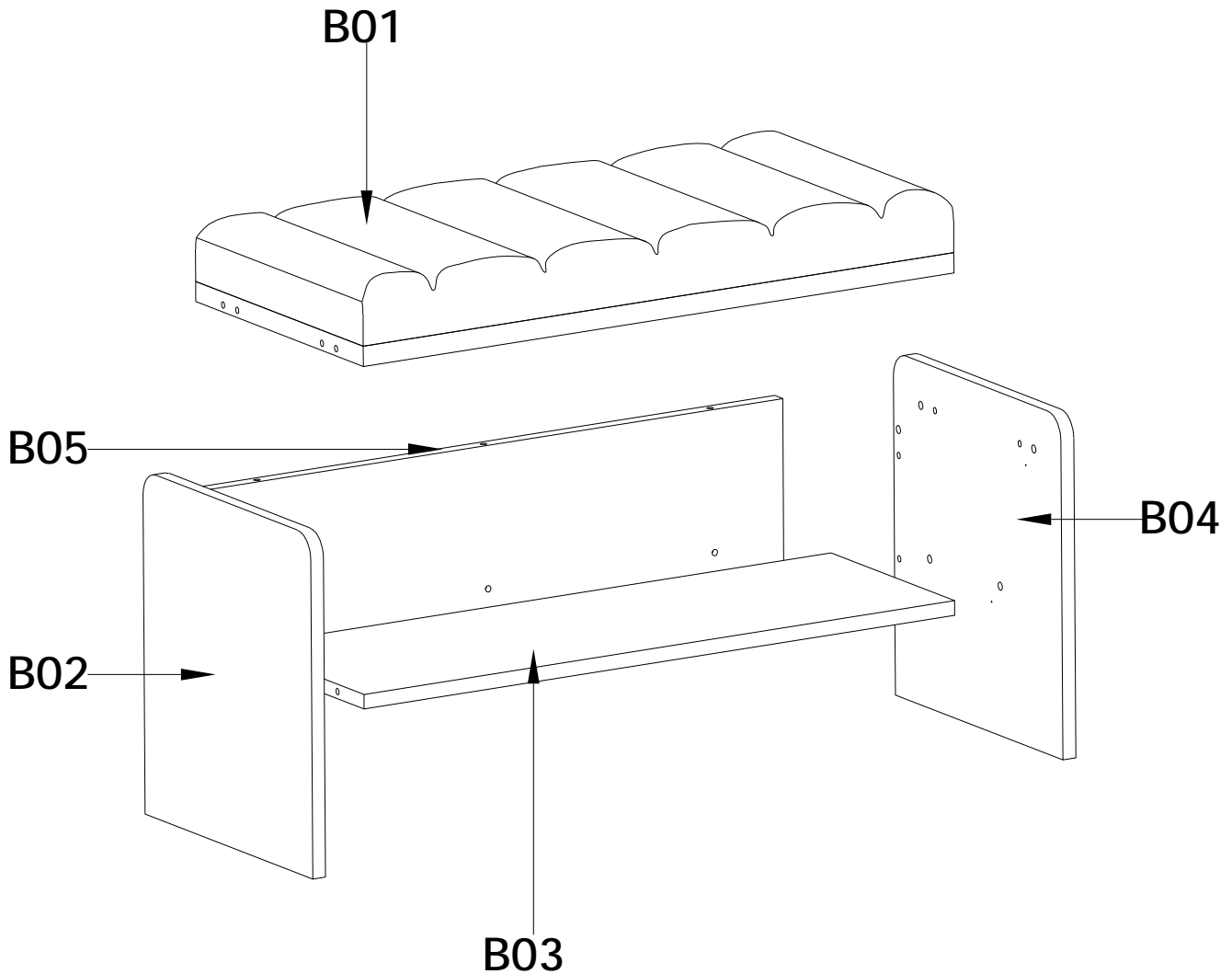

Shoe Bench Assembly Hardware

Step 1

H1118(C)

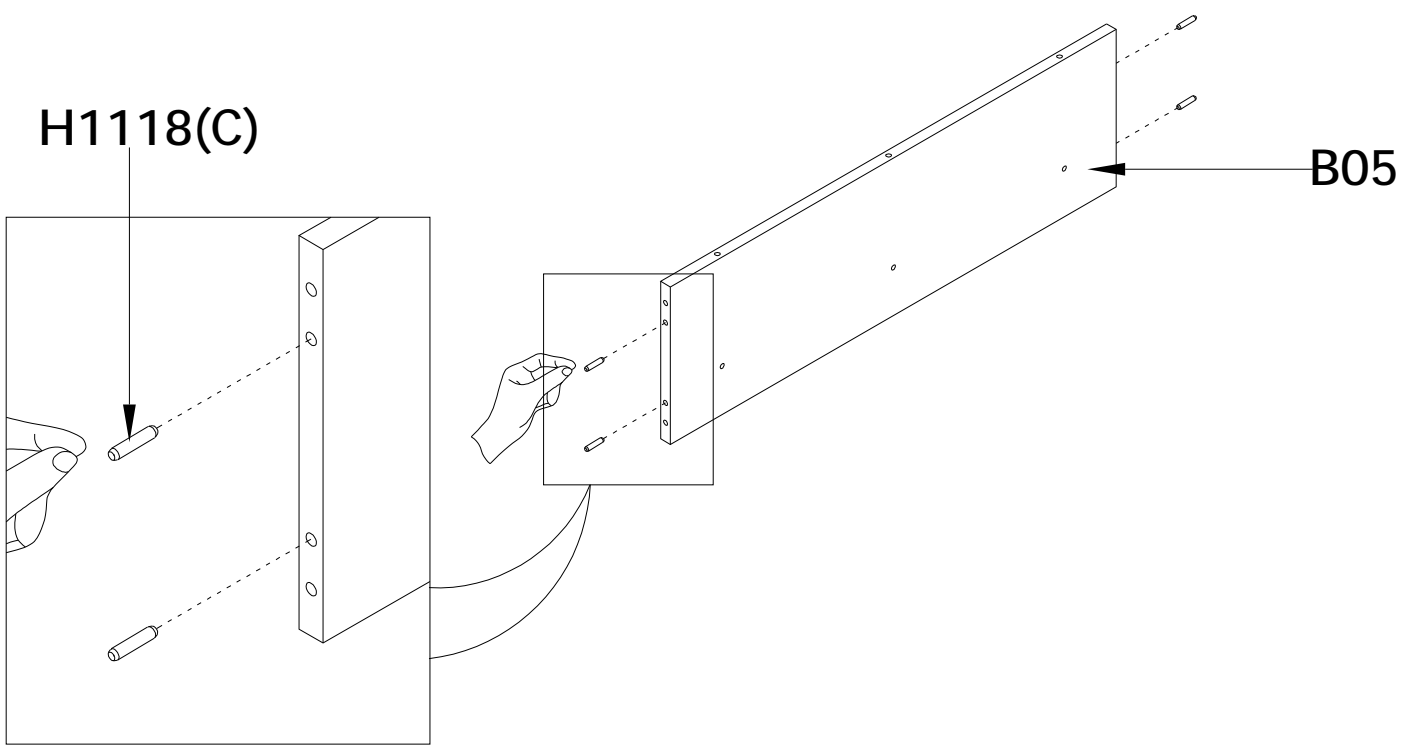
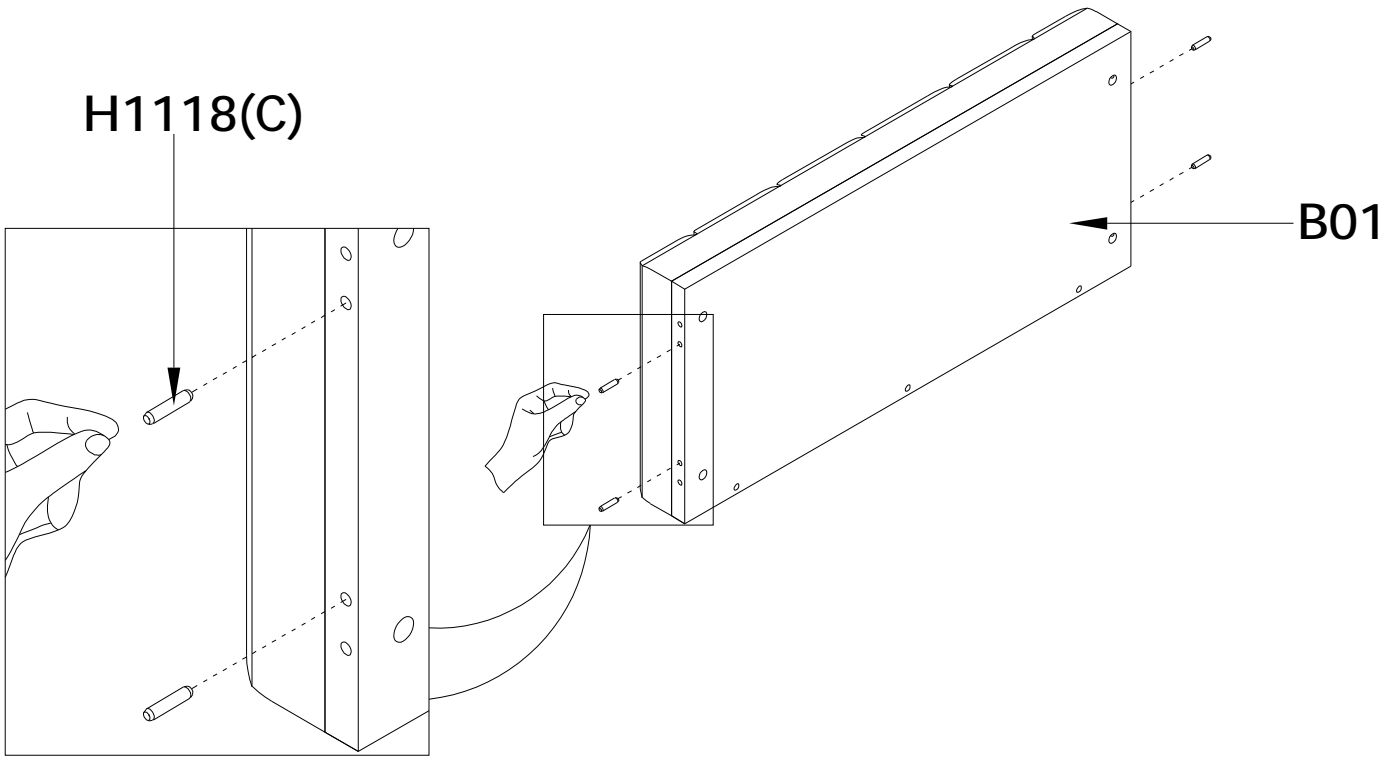
8PCS

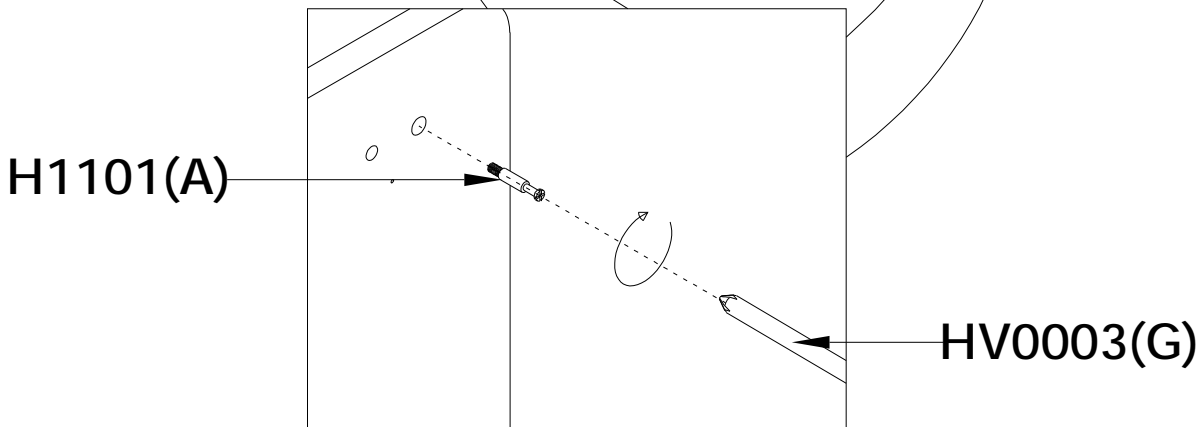
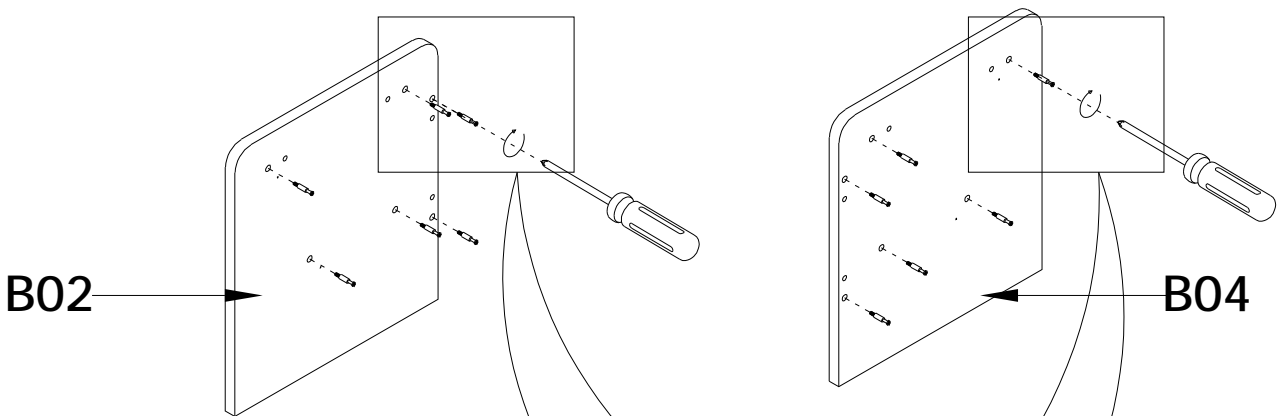
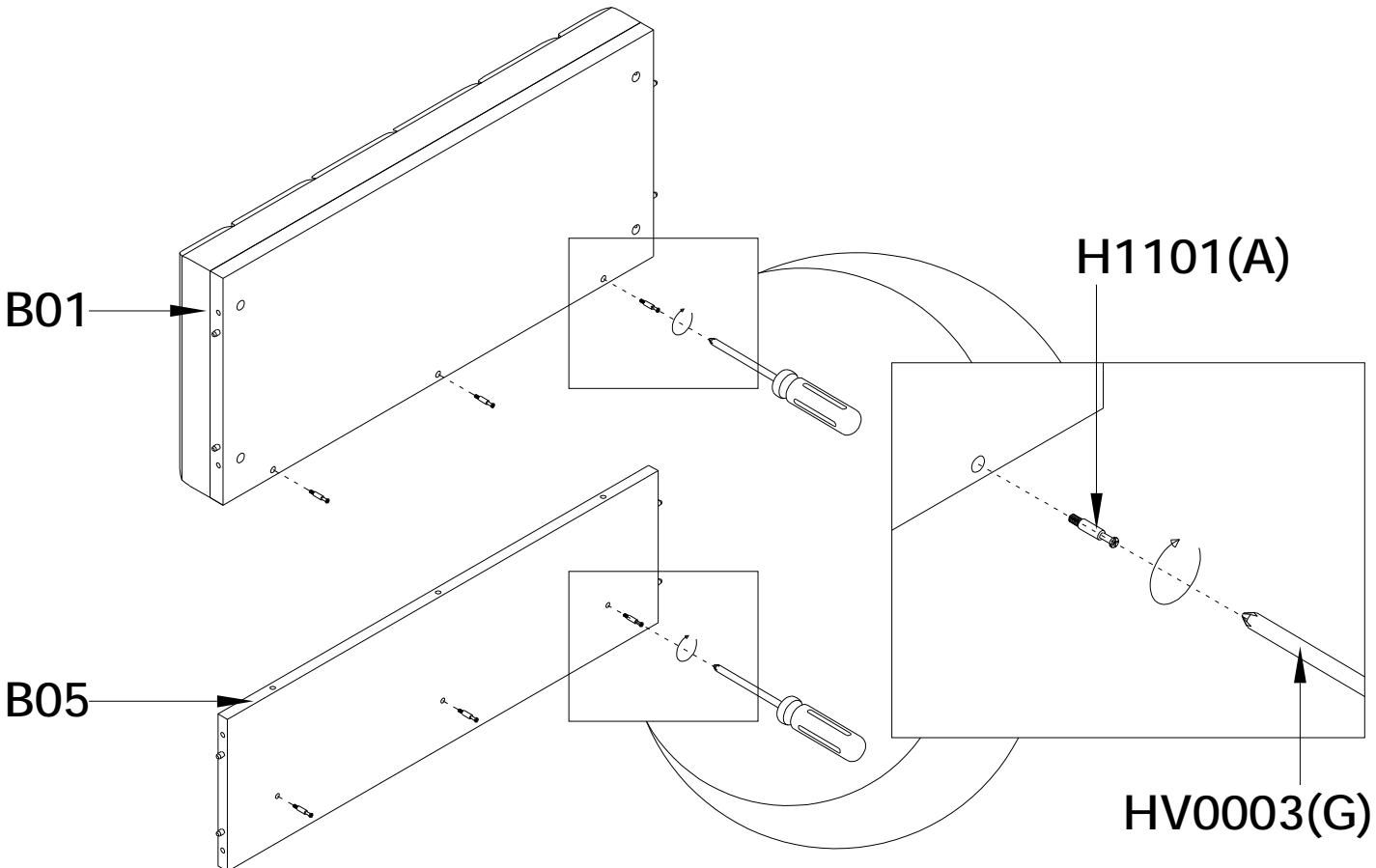

Step 2

H1101(A)	HV0003(G)
18PCS	1PC

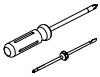

Step 3

H1201(B)	HV0003(G)
	
3PCS	1PC

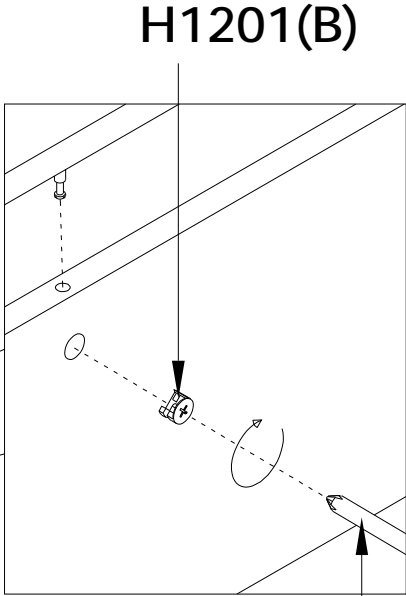
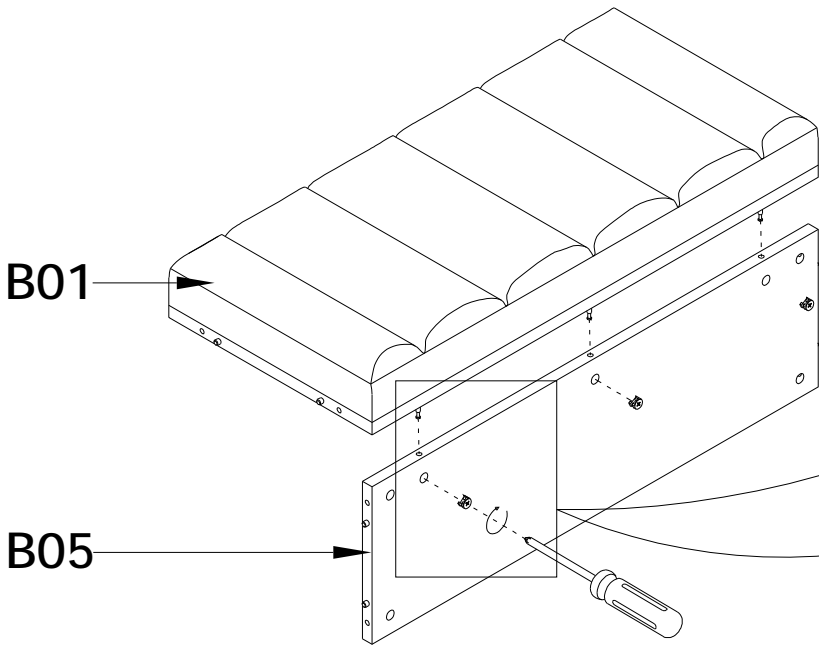

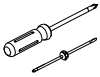

HV0003(G)

Step 4

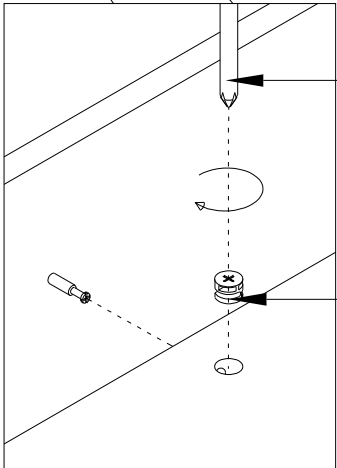
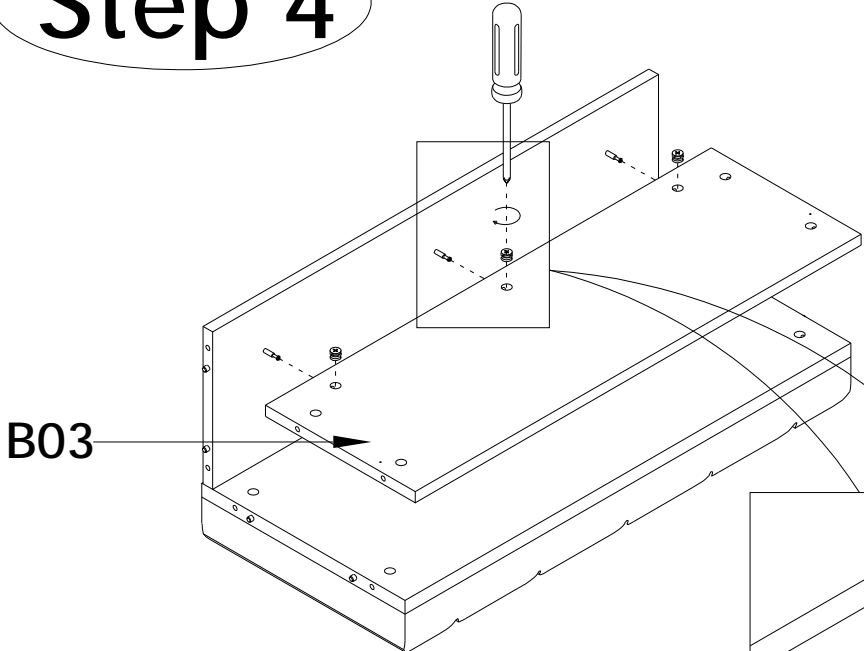
H1201(B)	HV0003(G)
	
3PCS	1PC



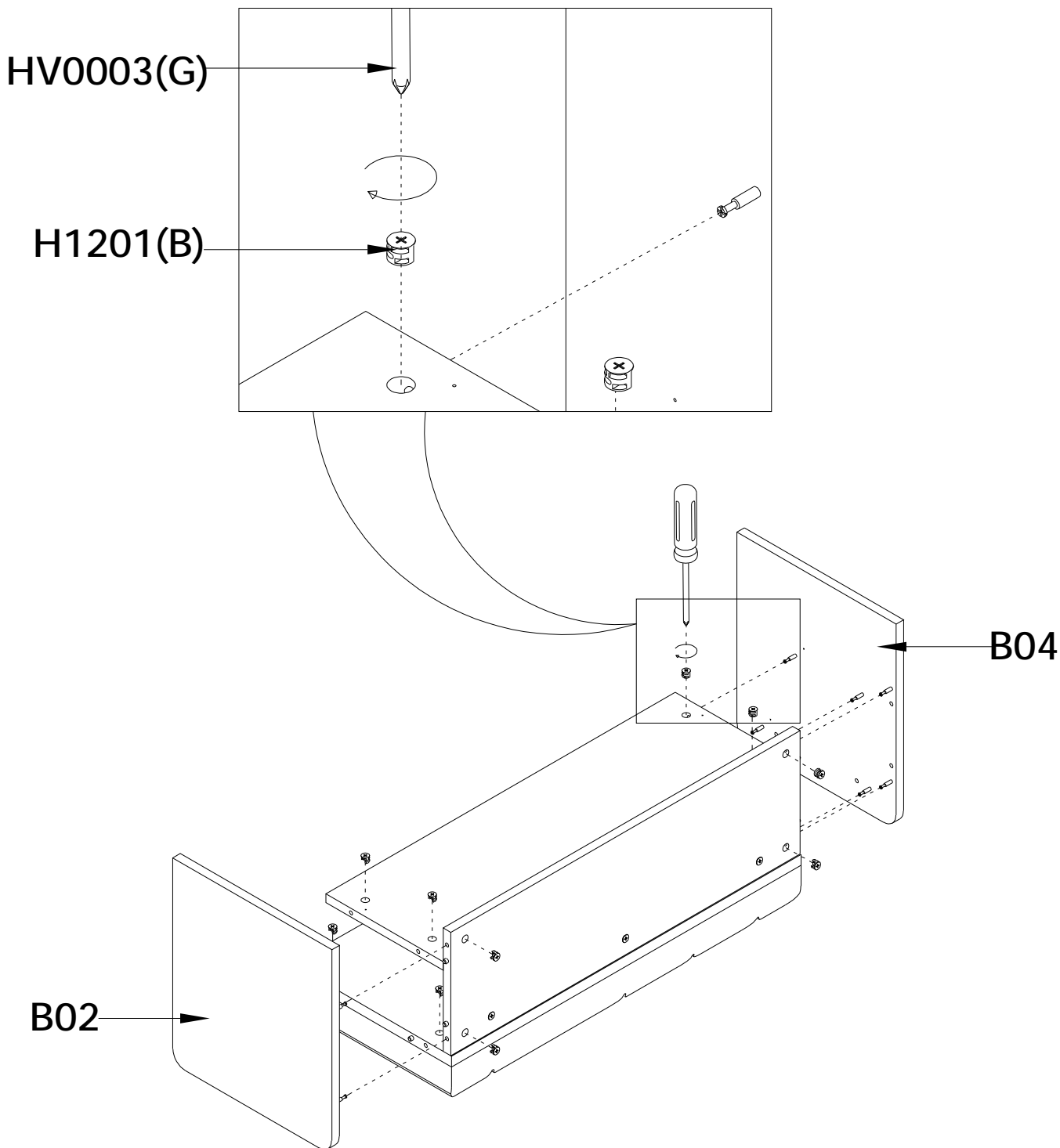

Step 5

H1201(B)  12PCS	HV0003(G)  1PC
---	--



 Attach HK0116(F) to the hole where H1201(B) has been installed.

Step 6

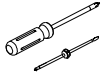
HA00122(D)  8PCS	HS0025 (E)  4PCS	HV0003(G)  1PC
---	--	---

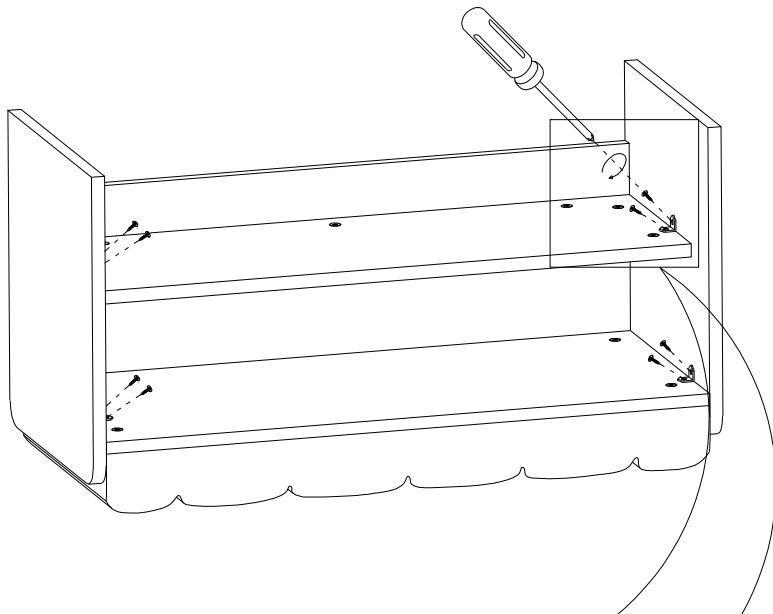

HV0003(G)

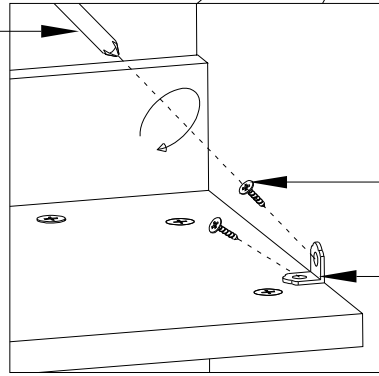

HA00122(D)

HS0025 (E)

