

Owner Manual

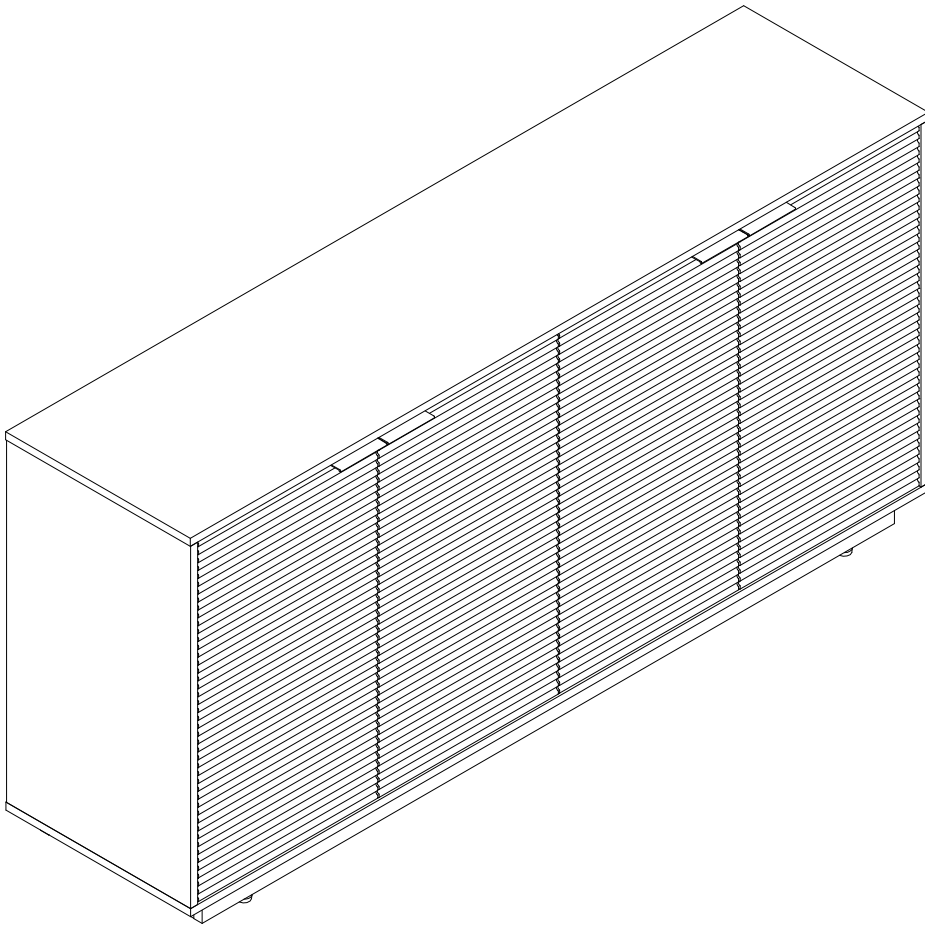

NOTE:

This brochure contains IMPORTANT safety info. Please read and keep for future reference.

MAINTAINANCE AND WARNING

- 1.Keep furniture away from heat sources.
- 2.Do not clean furniture with harsh cleaner or polishes.Do not use detergents,solvents,abrasives,spray packs or leather cleaner. Use non-color mild soap with warm water to clean spills(Mix 1:10 soap to water).
- 3.Do not place furniture under direct sunlight,material will possibly fade over time.
- 4.Do not use on site dry cleaning machine.Children should not climb or jump on the furniture.
- 5.Do not write on furniture that is not protectedby a padded barrier.
- 6.Not for commercial use,only for residential use.

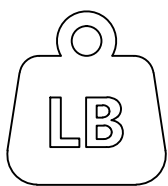

Weight Limitation

150 LBS

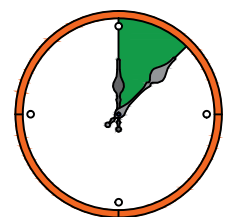





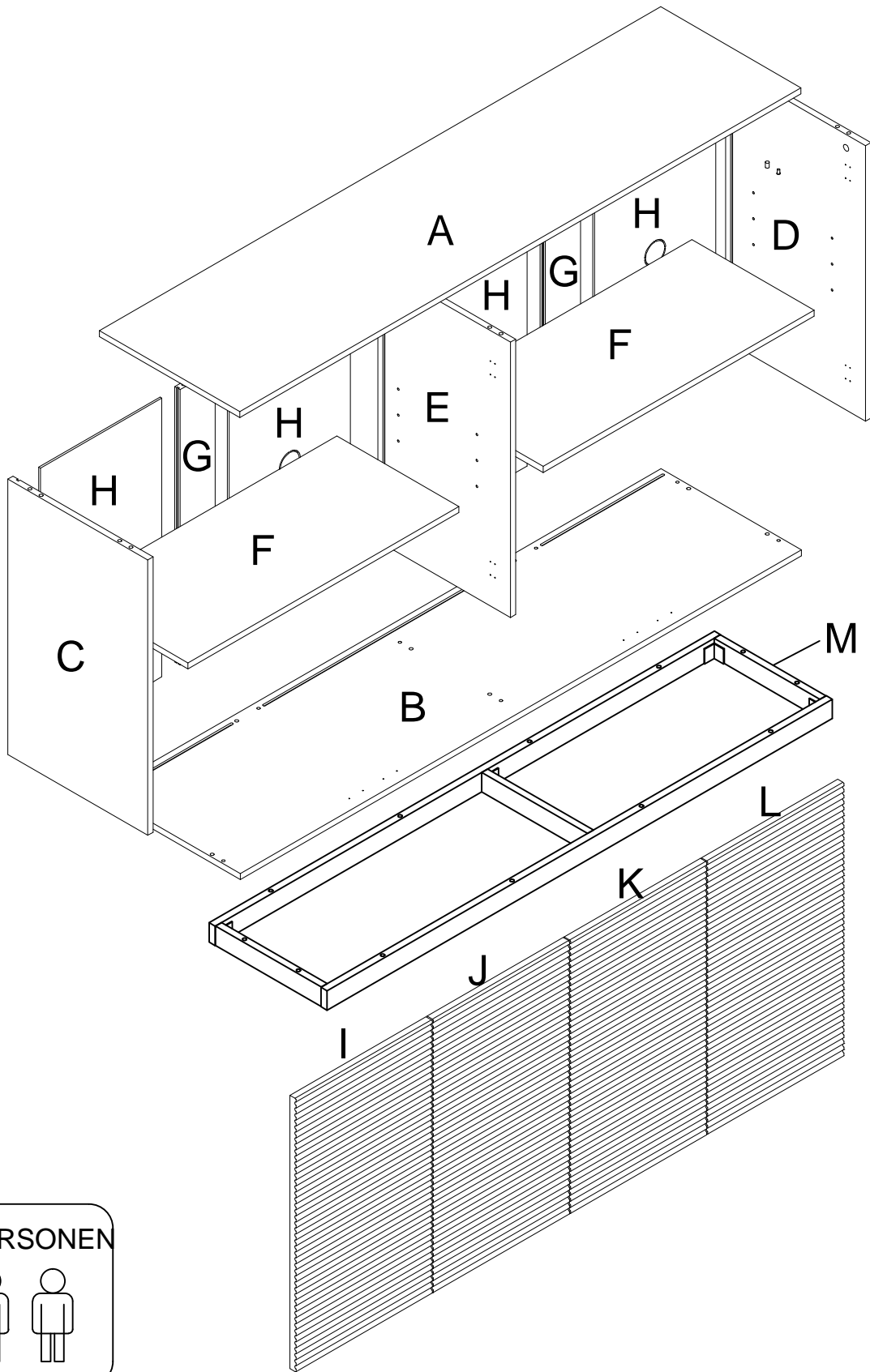

Around 45 min

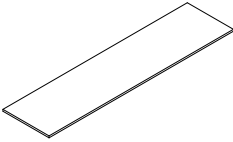
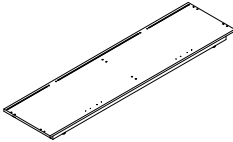

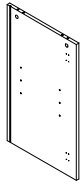
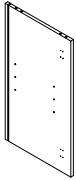
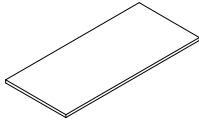

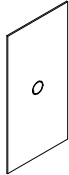
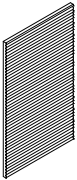
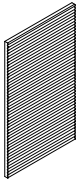
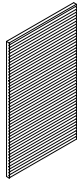

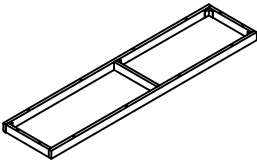
EXPLOSIVE VIEW

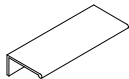
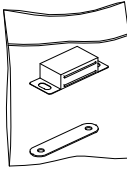

PARTS LIST

A	x1	B	x1	C	x1	D	x1
							
E	x1	F	x2	G	x2	H	x4
							
I	x1	J	X1	K	X1	L	X1
							
M	x1						
							

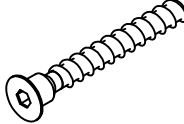
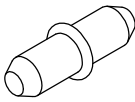

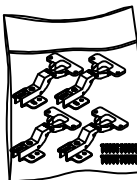
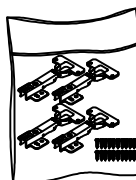
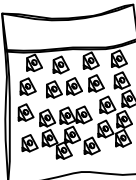
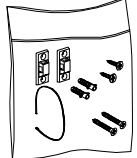
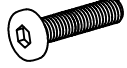

HARDWARE LIST

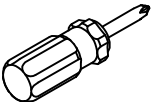
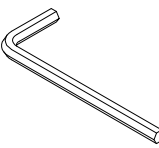
#1	x4	#2	x8	#3	x14	#4	x10	#5	x10	#6	x10
											
				ø8*30				ø15*11			
#7	x8	#8	x8	#9	x64	#10	x4	#11	x4	#12	x24
											
6*50				M3*14							
#13	x2	#16	x12								
											
		M6*50									

TOOL LIST

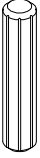
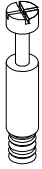
#14	x1	#15	x1
			
		M6	

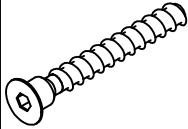
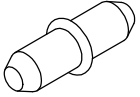
HARDWARE SPARE LIST

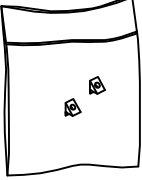
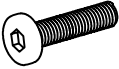
#3	x1	#4	x1	#5	x1	#6	x1	#7	x1	#8	x1
											
ø8*30MM				ø15*11				6*50			
#9	x6	#12	x2	#16	x1						
											
M3*14mm				M6*50							

ASSEMBLY INSTRUCTIONS

STEP-1

1. Install the #3 and #4 parts on the flat-laid A plate, and tighten them with the #14 part.
2. Unpack the #2 package. First, install the #2-1 part and fix it with the #9 screw.

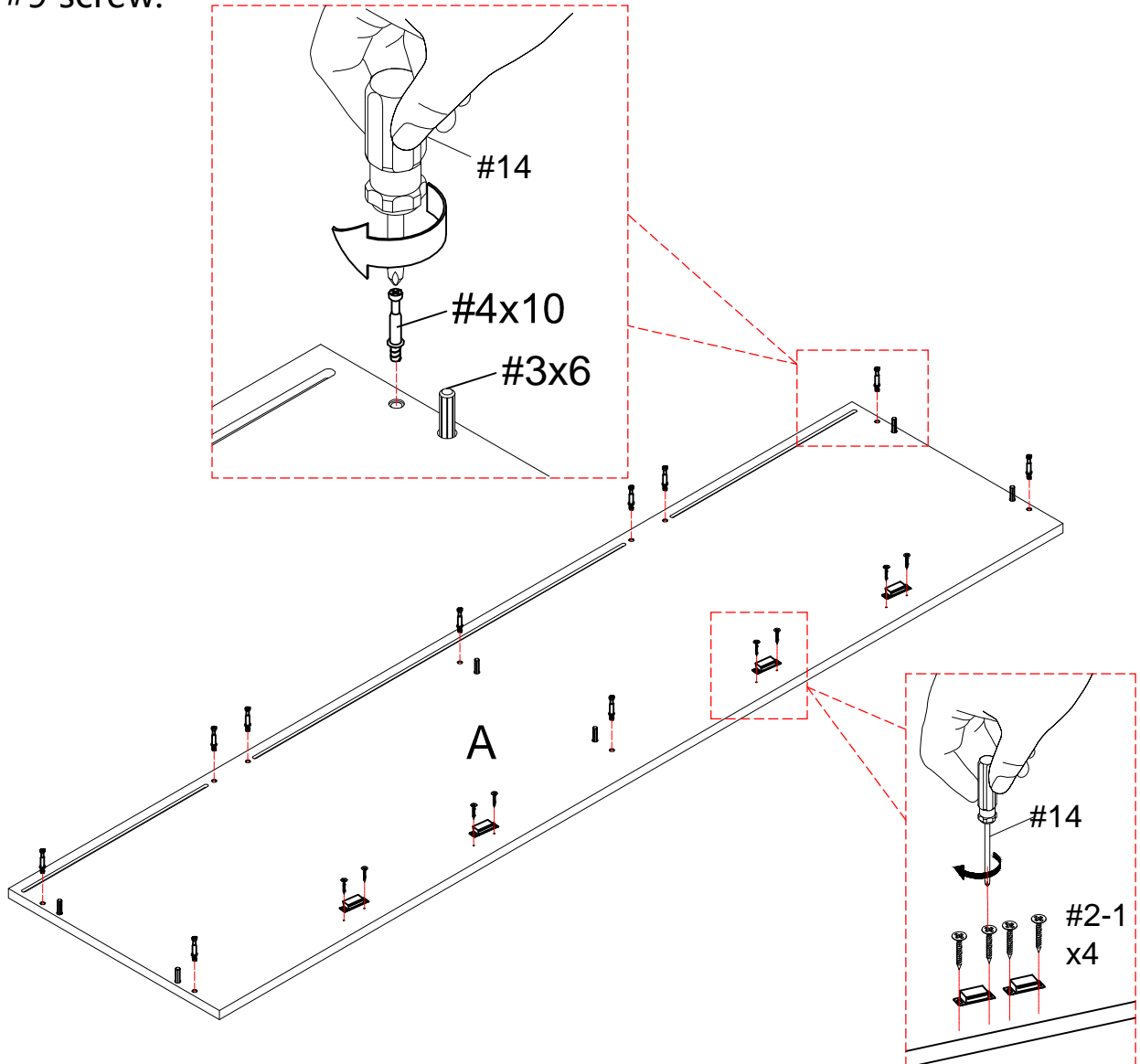

#2	x4	#3	x6	#4	x10	#14	x1
		8*30MM					

ASSEMBLY INSTRUCTIONS

STEP-2

Connect part A with parts C/D/E. Align the holes in the parts, insert the cam bolts into the corresponding holes of the vertical plate, and use a #14 screwdriver to tighten the nut #5. Seal the holes with the #6 sticker. Make sure that the groove is on the same side as shown in the picture

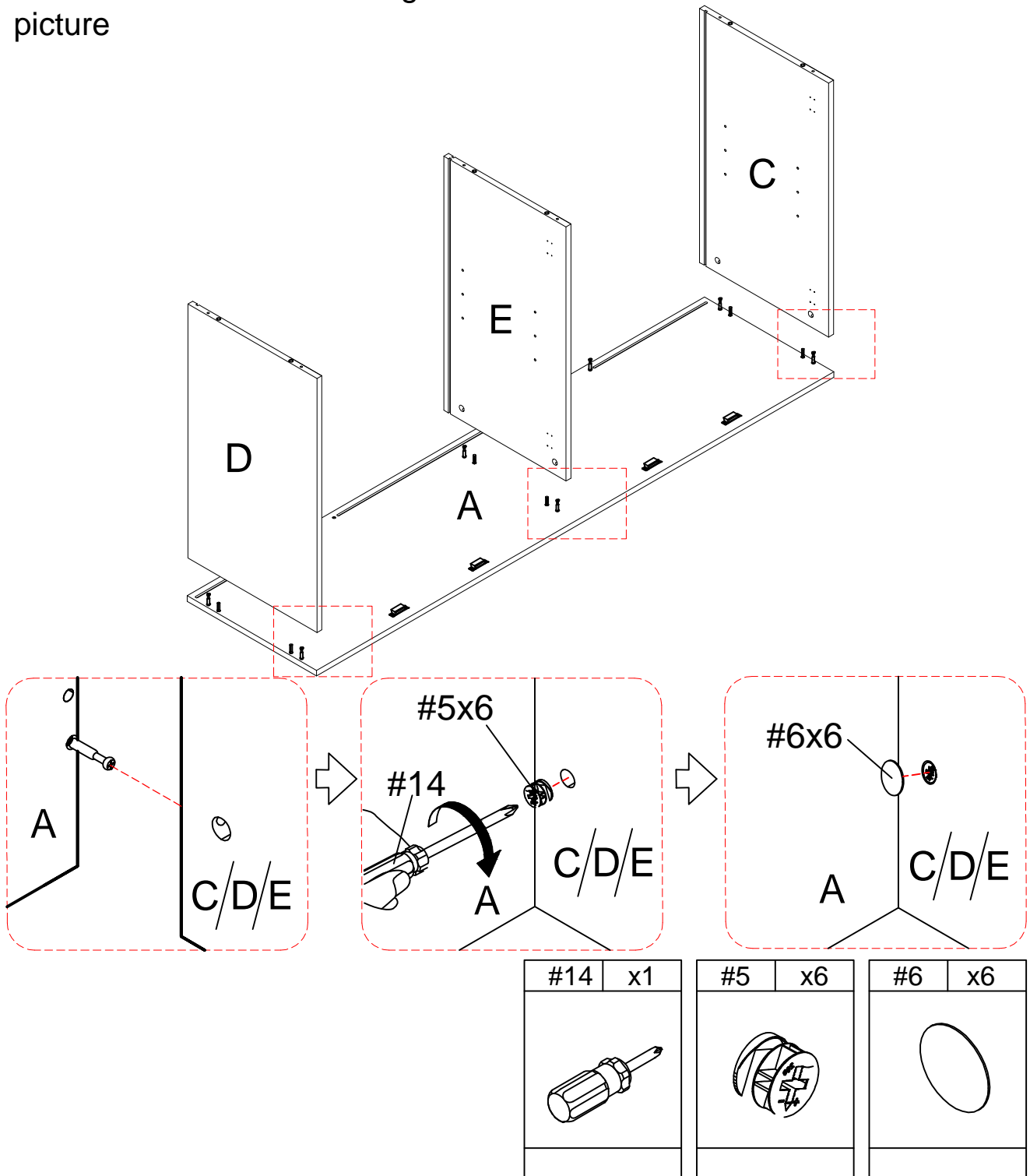



ASSEMBLY INSTRUCTIONS

STEP-3

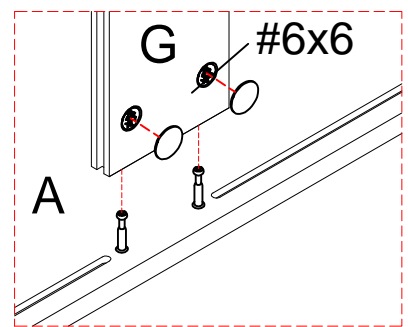
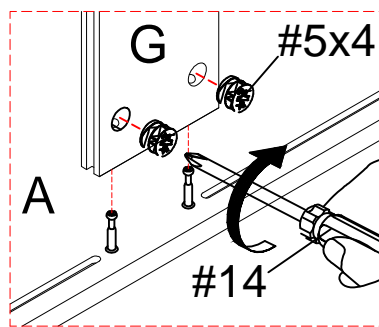
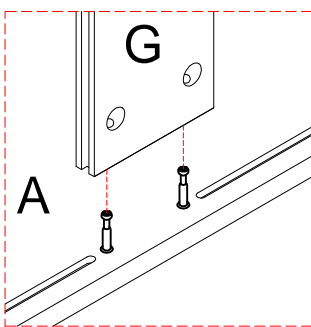
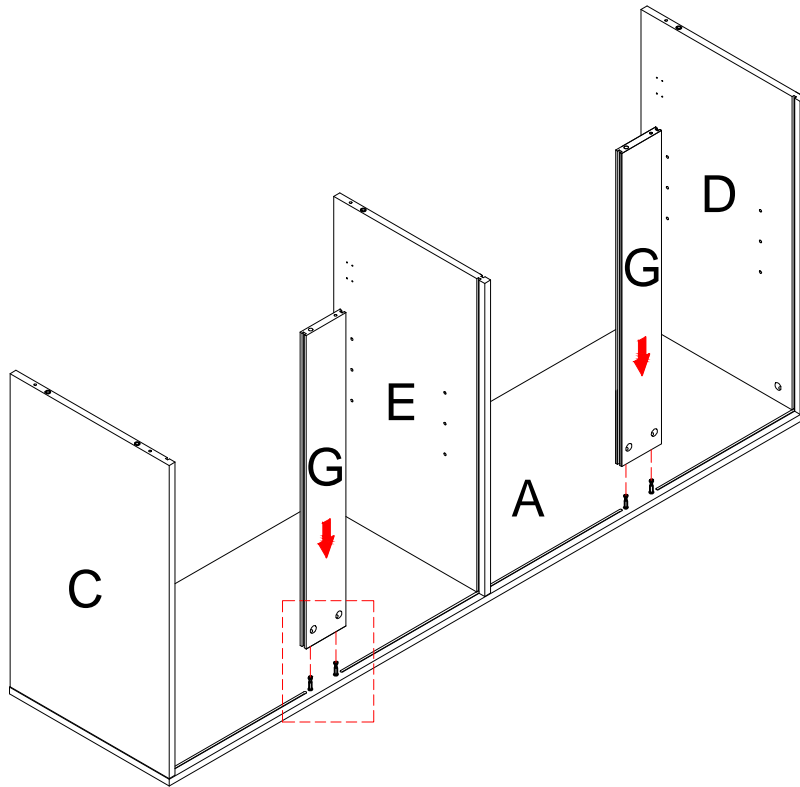
Connect part A with part G. Align the holes in the parts, insert the cam bolts into the corresponding holes of the vertical plate, and then use a #14 screwdriver to tighten the nut #5. Seal the holes with the #6 sticker.

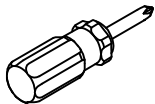

#14	x1	#5	x4	#6	x4
					
		ø15*11			

ASSEMBLY INSTRUCTIONS

STEP-4

Carefully align and slide panel (H) into the groove along rear edge of pre-assemble step 3.

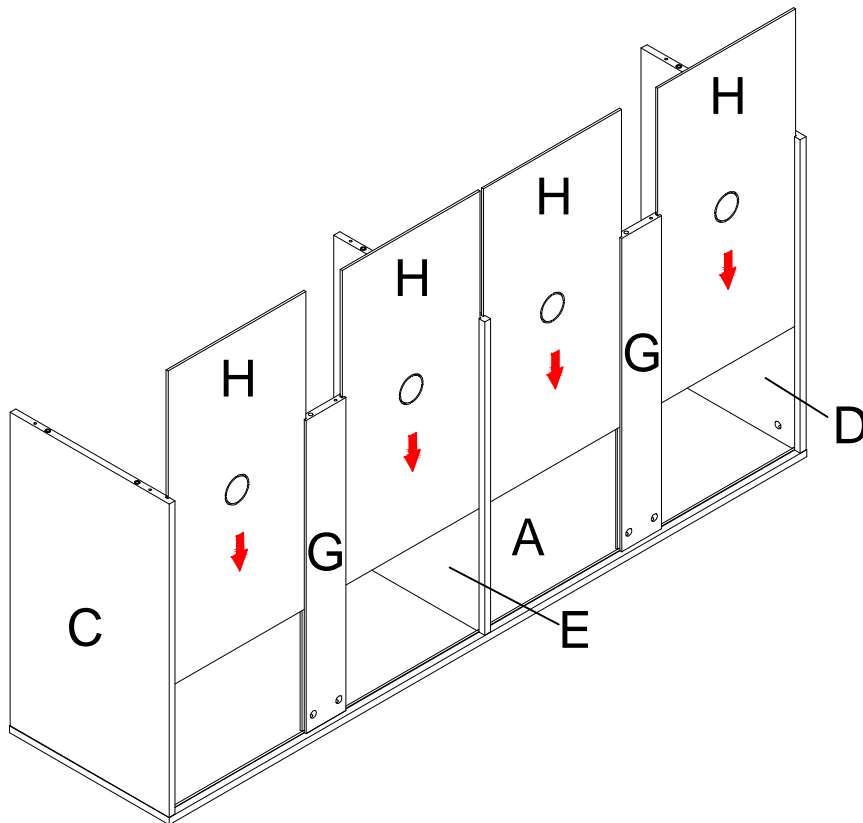

ASSEMBLY INSTRUCTIONS

STEP-5

Insert part (M) into the corresponding position of panel (B), and then use flat bolt #16 to attach part (M) to part (B), make sure all holes aligned and tighten all bolts with screwdriver #15.

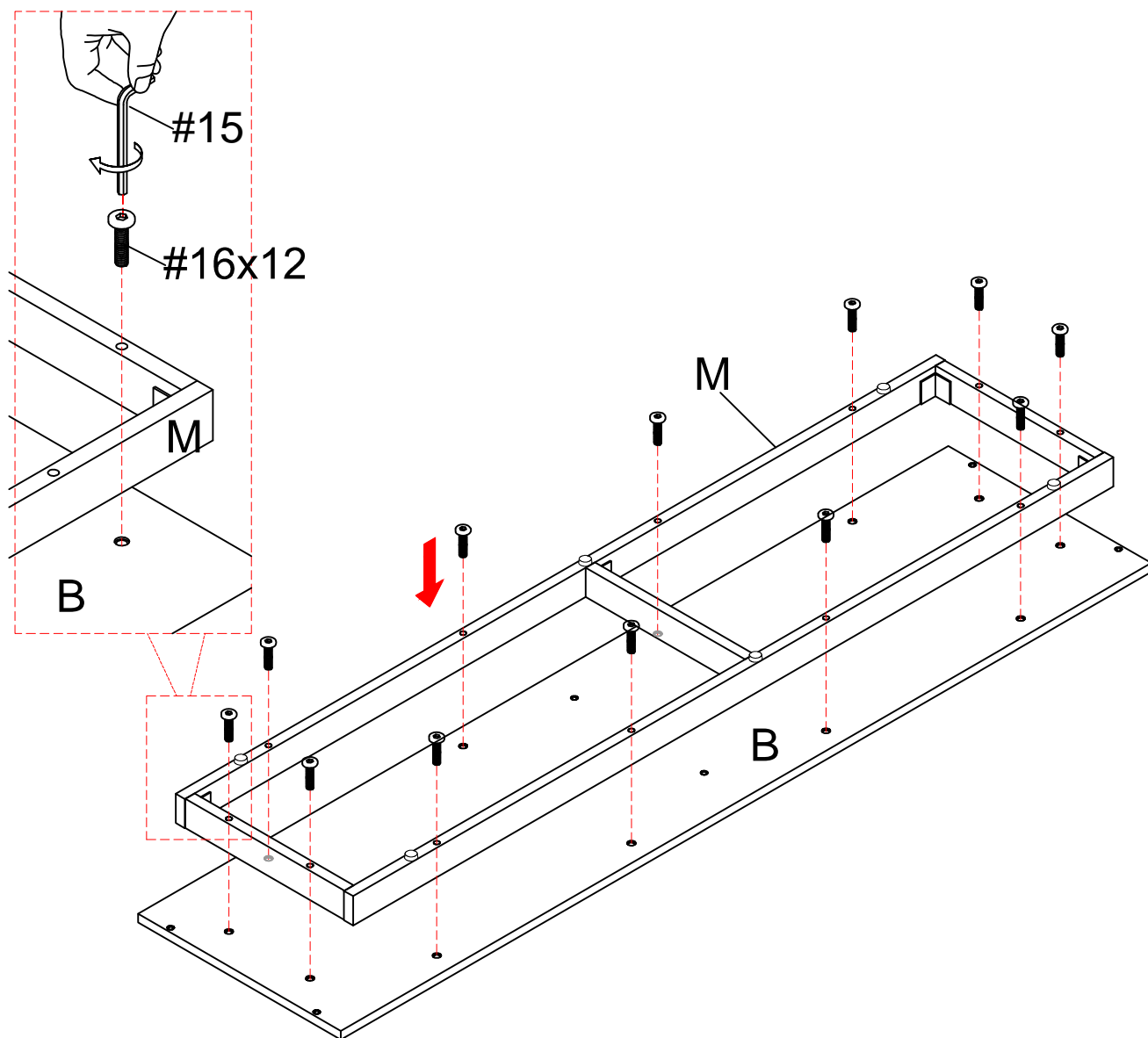

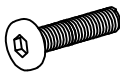
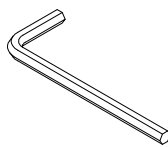
#16	x12	#15	x1
			
M6*50		M6	

ASSEMBLY INSTRUCTIONS

STEP-6

1. Insert parts C/D/E/G into the #3 dowel.

2. Prepare part B, align the holes on parts C/D/E/G, and use a #15 screwdriver to tighten the #7 screw.

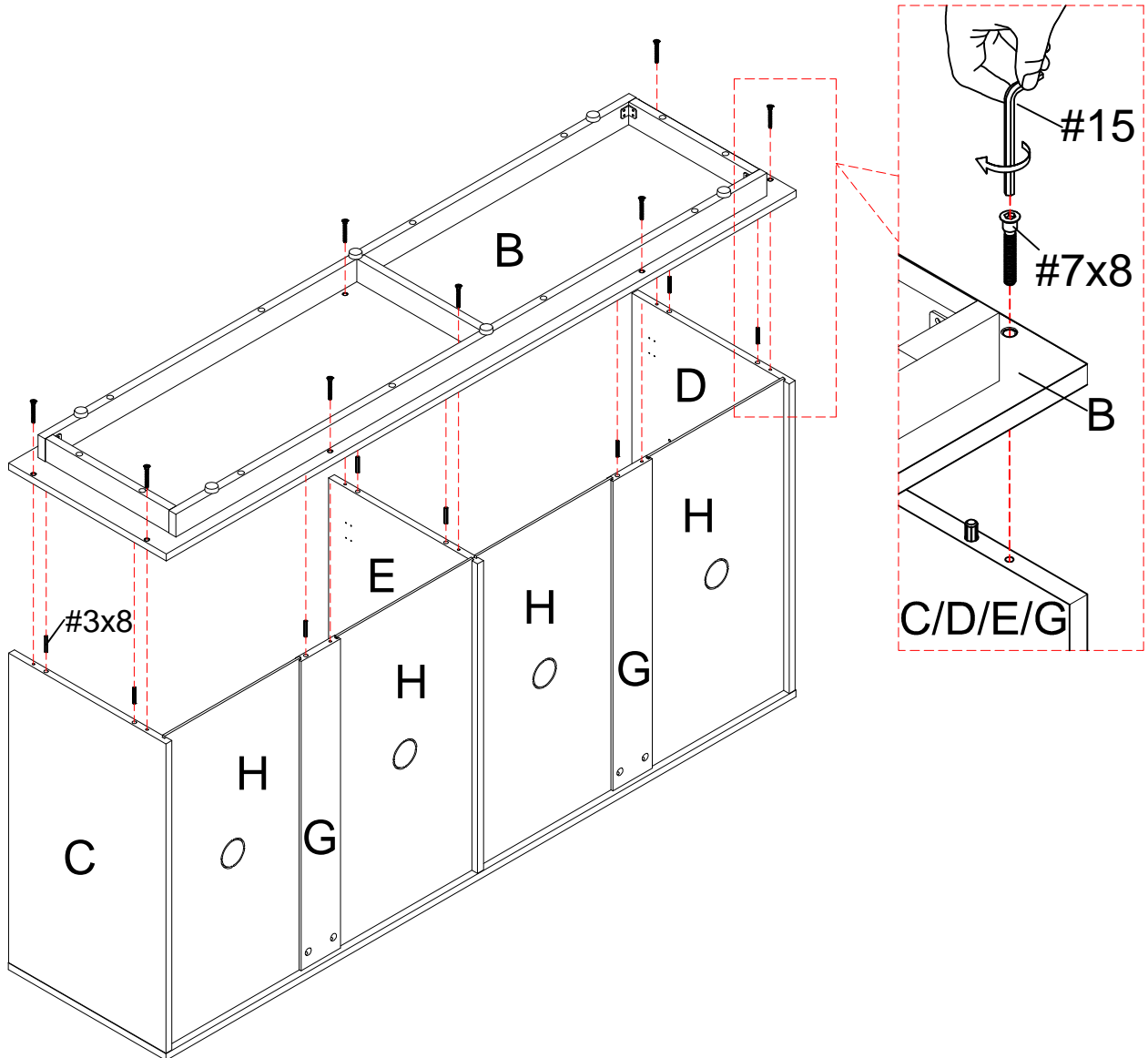

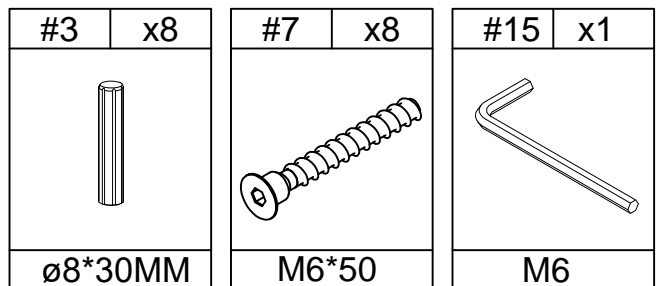
#3	x8	#7	x8	#15	x1
					
ø8*30MM		M6*50		M6	

ASSEMBLY INSTRUCTIONS

STEP-7

Lay Component (L) and Component (I) flat with the holes facing upwards. Use a #14 screwdriver to tighten the screws that come with the #10 hinge.

As shown in the figure, use a #14 screwdriver to tighten the #9 screws for #1 and #2-2.

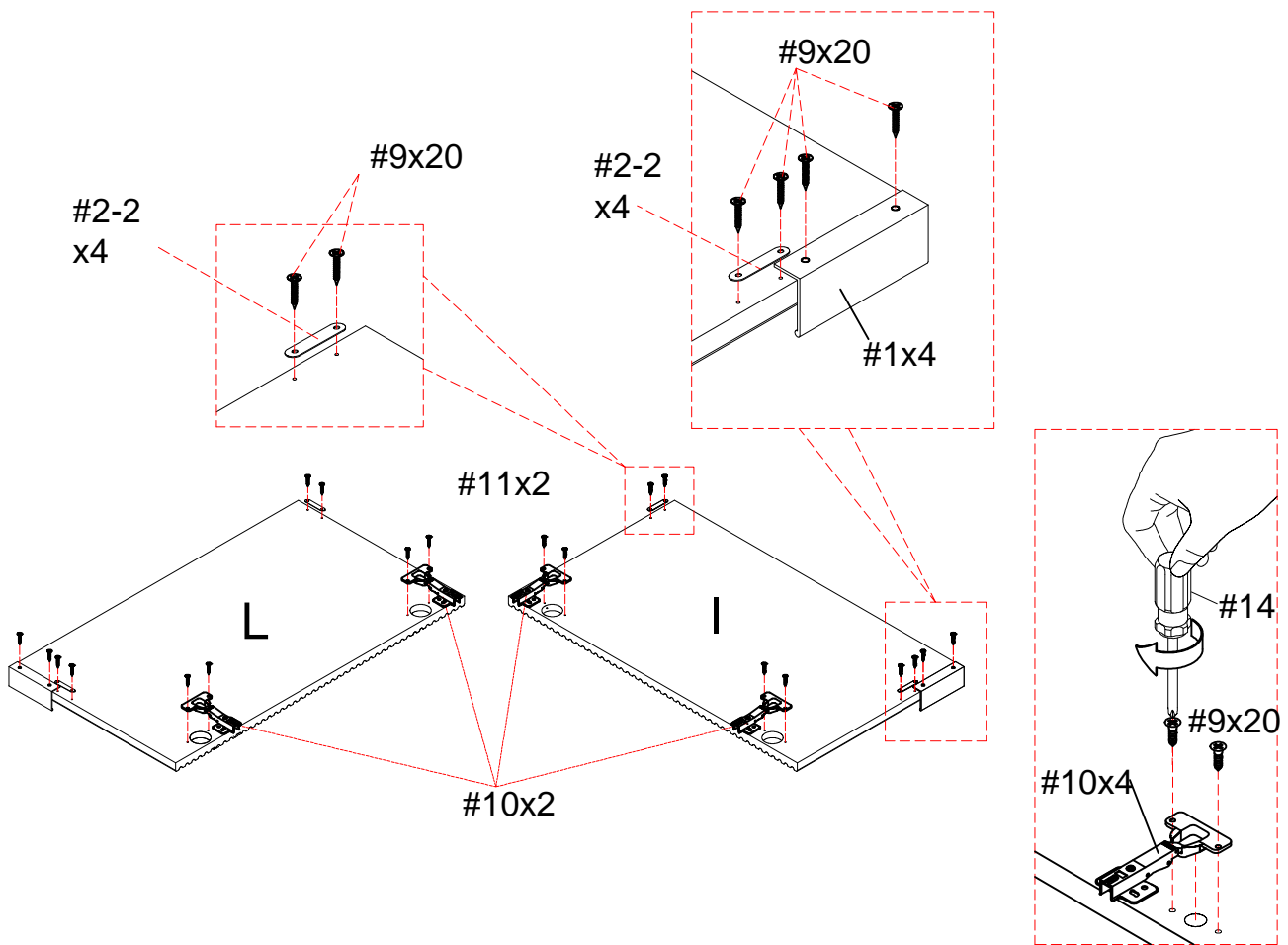

#1	x2	#2	x4	#9	x20	#10	x4	#14	x1
				M3*14					

ASSEMBLY INSTRUCTIONS

STEP-8

Lay Component (J) and Component (K) flat with the holes facing upwards. Use a #14 screwdriver to tighten the screws that come with the #11 hinge.

As shown in the figure, use a #14 screwdriver to tighten the #9 screws for #1 and #2-2.

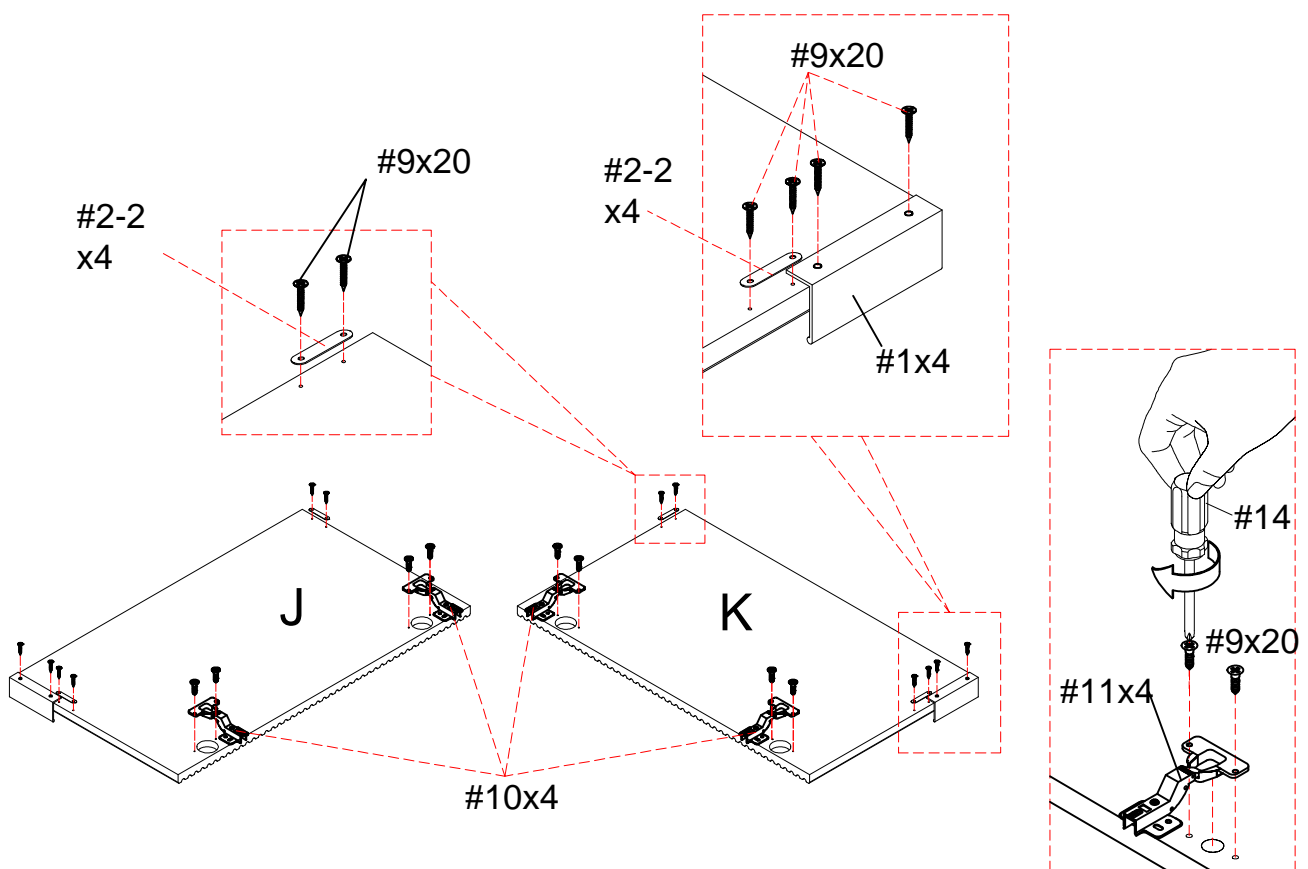

#1	x2	#2	x4	#9	x20	#11	x4	#14	x1
				M3*14					

ASSEMBLY INSTRUCTIONS

STEP-9

Install the door panels. Install door panel I on part C, install door panel J on the left side of part E, install door panel K on the right side of part E, and install door panel L on part D. Use a #14 screwdriver to tighten the screws.

Please note that the position of the door must strictly follow the instructions

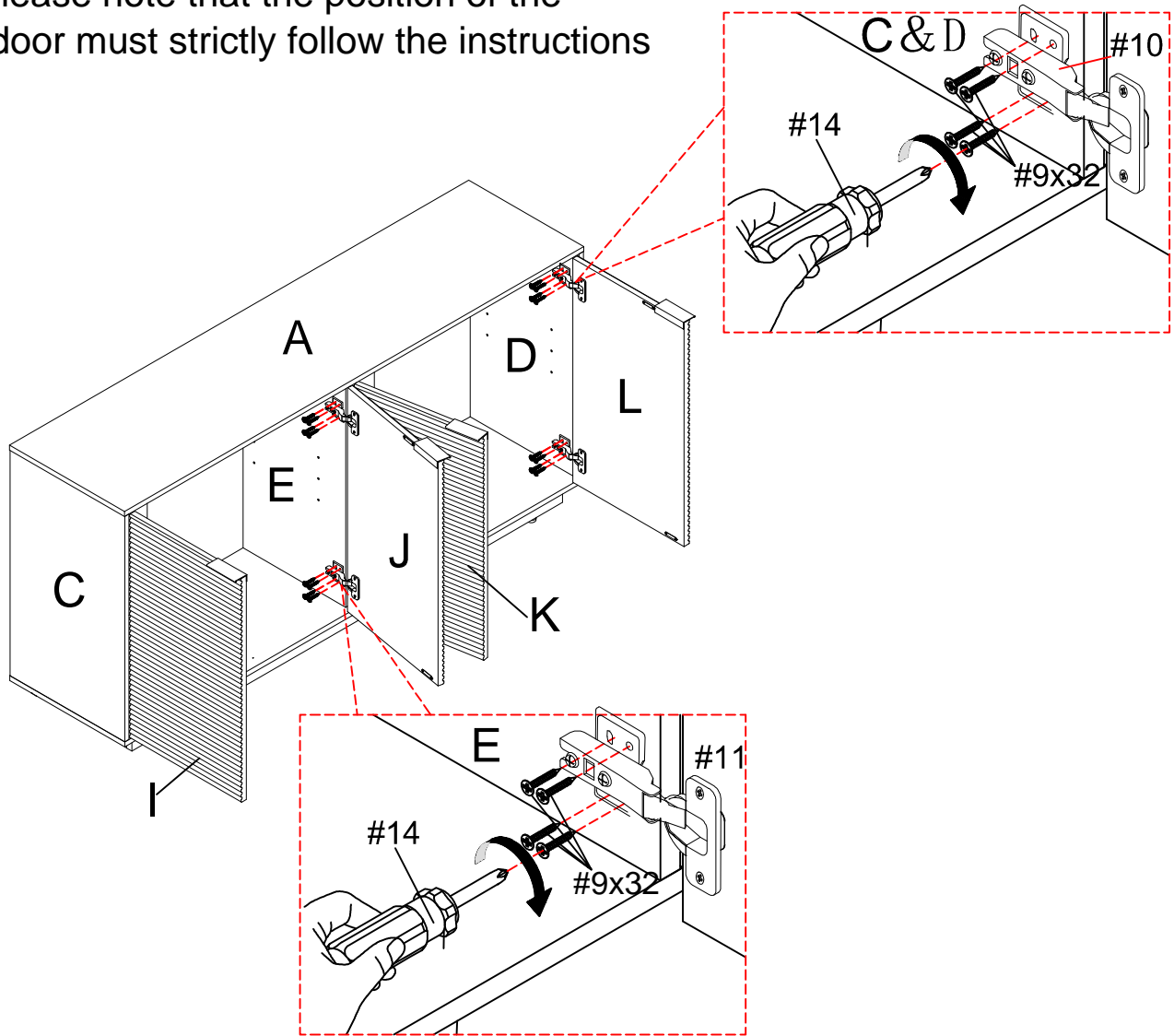

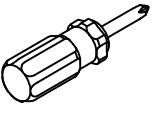
#9	x32	#14	x1
			
M3*14			

ASSEMBLY INSTRUCTIONS

STEP-10

Instructions for Hinge Adjustment

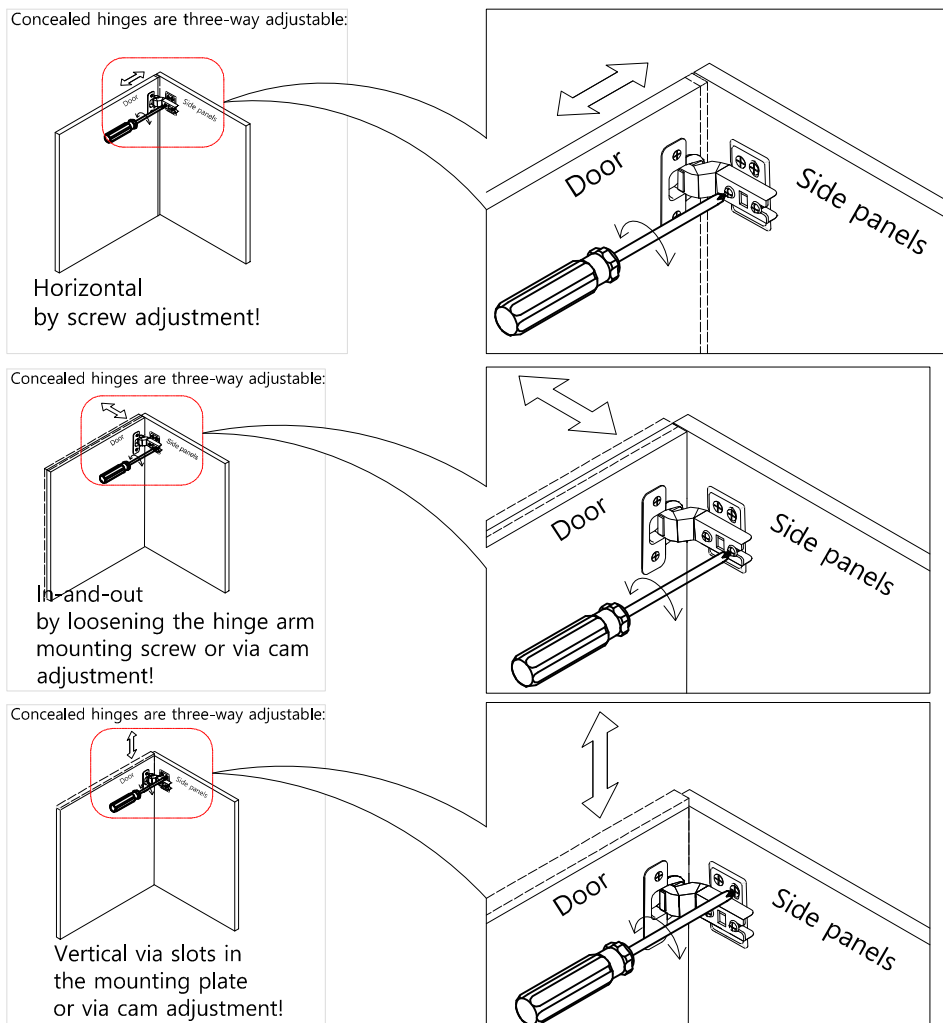



ASSEMBLY INSTRUCTIONS

STEP-11

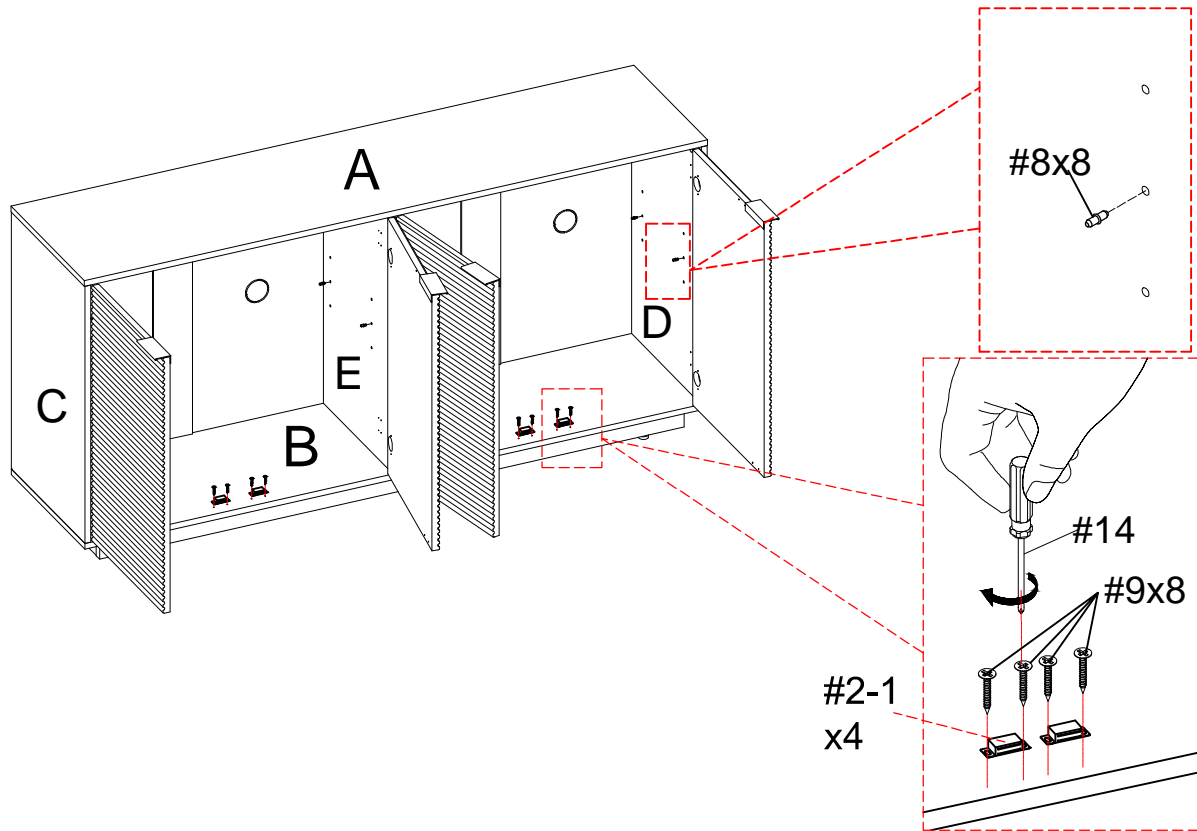
1. Install the #8 shelf pins on parts C, D and E. Note that part E needs to have the shelf pins installed on both sides. The shelf pins can be adjusted up and down at will.
2. Install #2-1 on Part B and tighten the #9 screw with a #14 screwdriver.

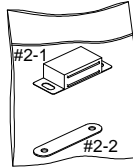
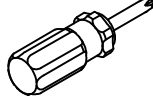

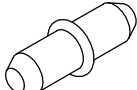
#2	x4	#14	x1	#9	x8	#8	x8
							
				M3*14			

ASSEMBLY INSTRUCTIONS

STEP-12

Put part F on the shelf pins of the cabinet body.

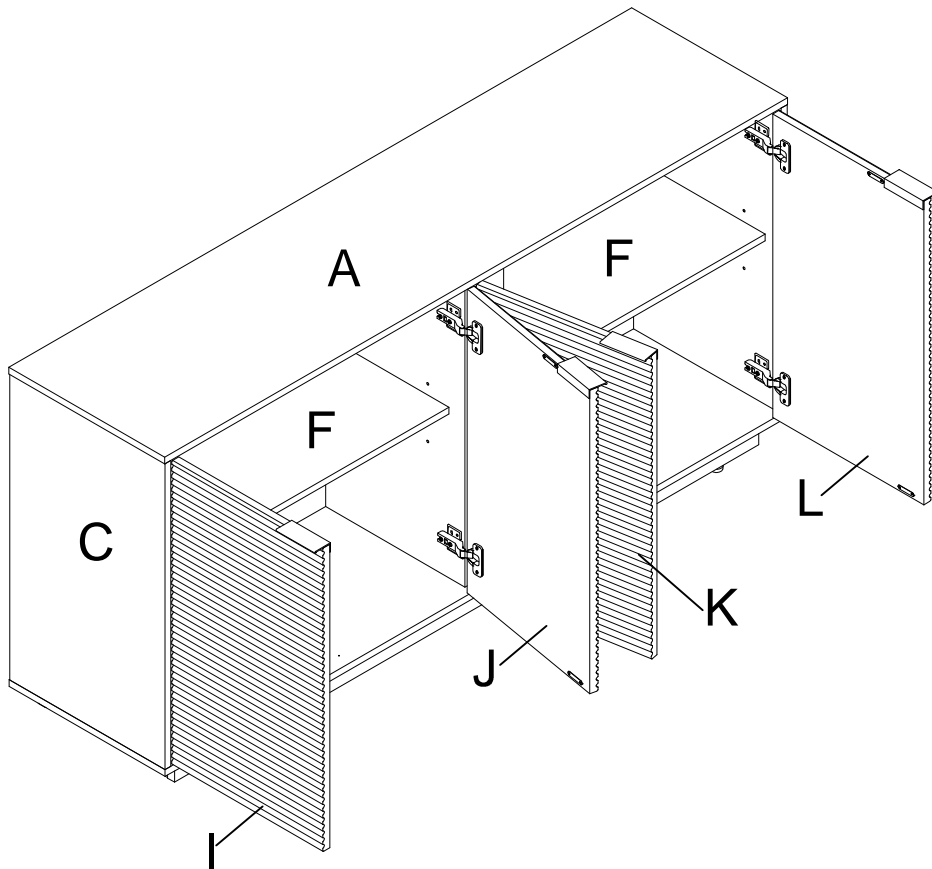

ASSEMBLY INSTRUCTIONS

STEP-13

Use screw #9 to attach part #12 to bottom panel(A)&(B)&(C)&(D)&(E)&(G),tighten screw #14 with screwdriver #9.

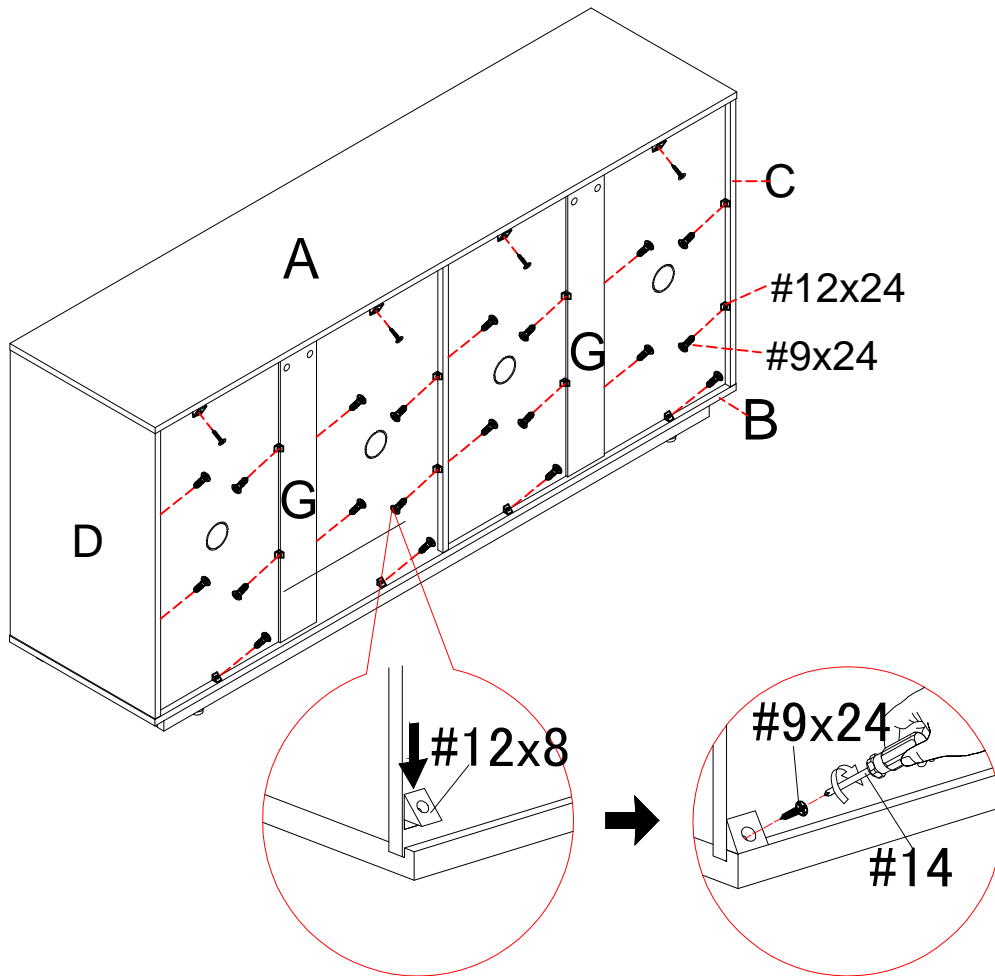

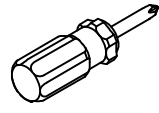
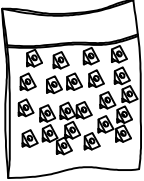

#9	x24	#14	x1	#12	x24
					
M3*14					

ASSEMBLY INSTRUCTIONS

STEP-14

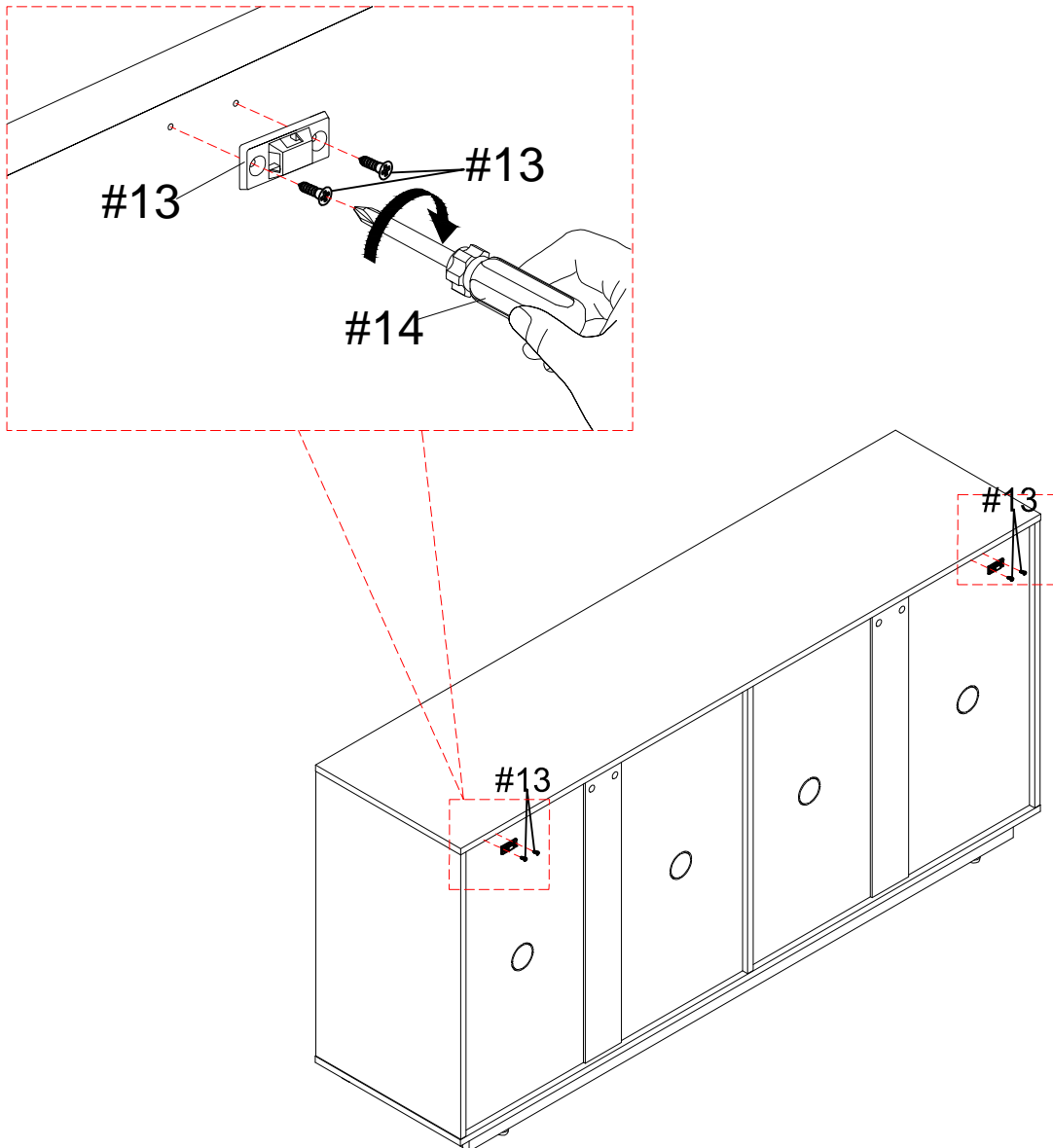
1. Use nylon packaging #13 Inside screw to attach bracket to the corresponding hole of top panel(A), tighten screw with screwdriver #14.

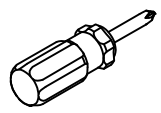

#13	x2	#14	x1
			

ASSEMBLY INSTRUCTIONS

#13	x2	#14	x1	①	x2	②	x4	③	x4

STEP-15

1. Mark the position on the wall, that corresponds to the location of bracket ① on the back of top panel A; Drill and insert the expandable screw ② by hammer.
2. Assemble the bracket ① to the wall. Align the hole in the bracket ① with the expandable screw ②, use screw ③ to attach it, tighten screw ③ with screwdriver #14.

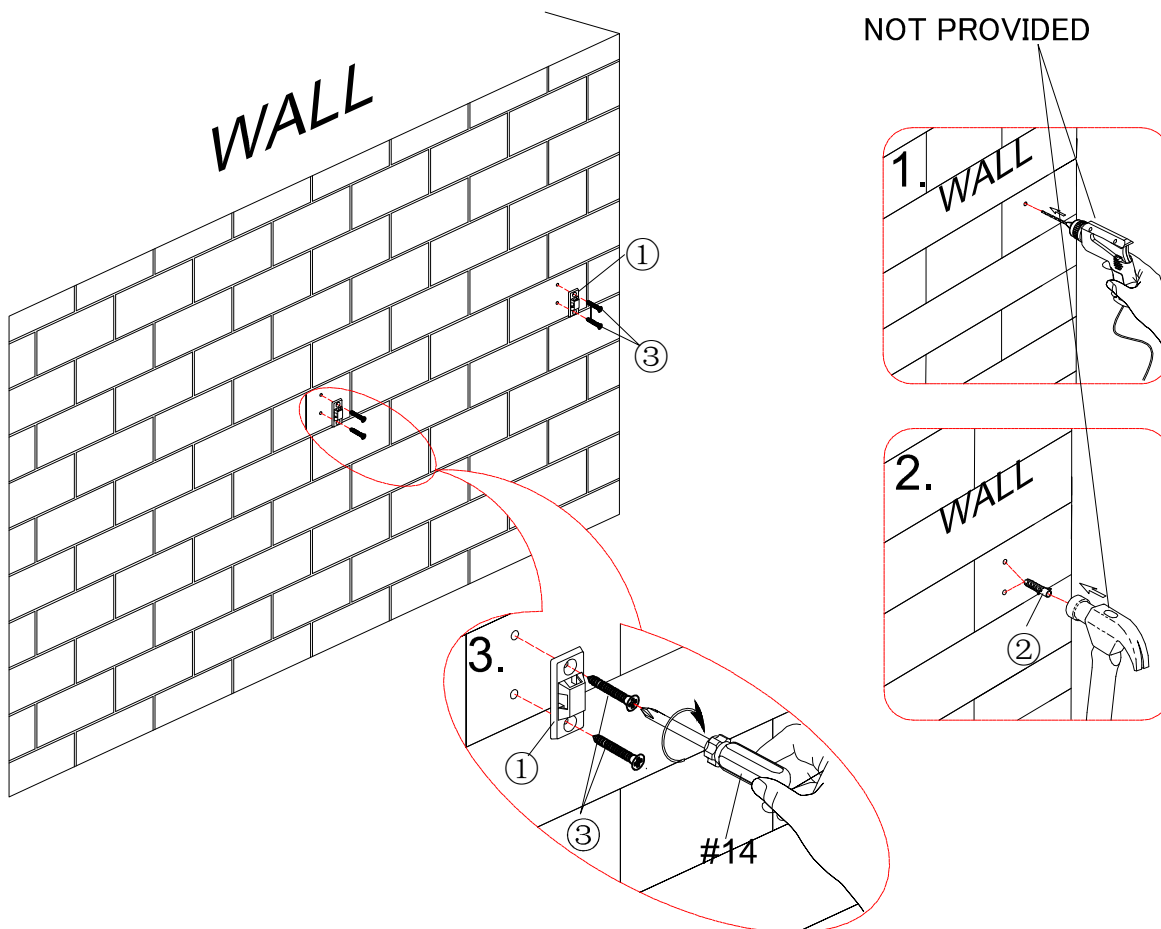

ASSEMBLY INSTRUCTIONS

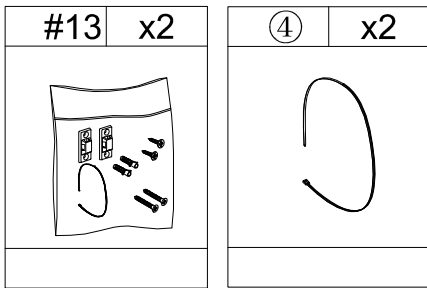

STEP-16

3. Let the plastic belt ④ pass through bracket ① and pull tightly.

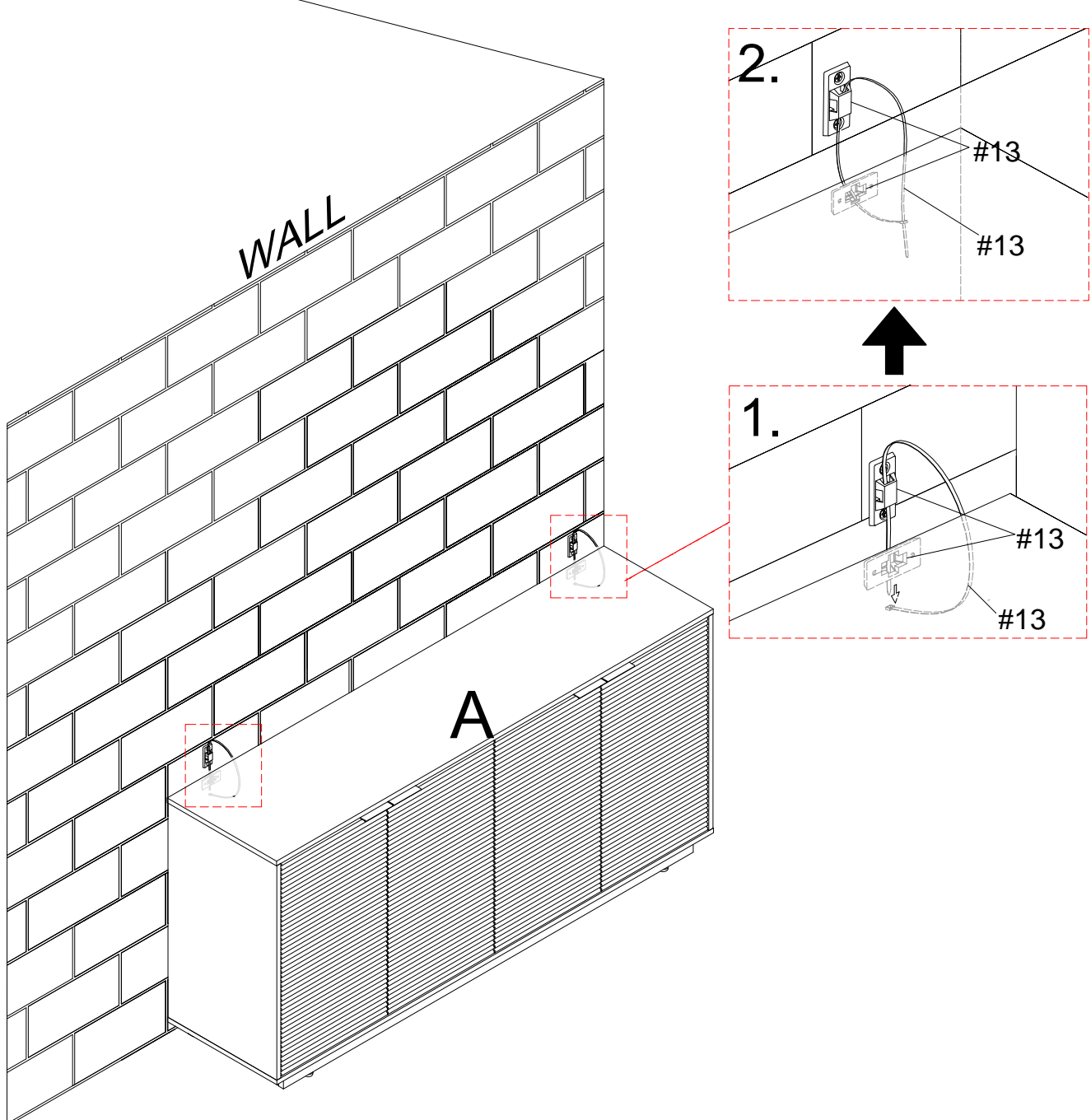

WARRANTY

1. We strive to offer high-quality products, and we also try our best to satisfy each and every customer that orders from us with product or service as needed.
2. We provide 30 days warranty starting from the time you receive the item. Each customer must provide a record of their order such as the order number, or item receipt for any items that are out of the warranty period you may also still receive.
3. Replacement parts by purchasing them with our company if they are available.