

## ASSEMBLY INSTRUCTIONS (ZQF)

RED THIN SEAT  
WHITE THIN SEAT  
BLACK THIN SEAT

Made in China

We want to make sure it is complete and to your satisfaction. Please check all packing material carefully for small parts which may have come loose inside the carton during shipment. Hardware can be identified by bright red packaging. Separate, identify, and count all parts and hardware to make sure they match with the illustrations herein and are all present. Contact information is given at the bottom of these instructions. If you feel the item is defective beyond a resolution with part replacements, please return this product with your receipt to the place of purchase. If purchased from an internet retailer, please contact their customer service department. Photo's and additional information may be requested to validate the claim. Thank you.

ATTENTION: SOME LETTERED PARTS LISTED ON THE INSTRUCTION SHEET MAY NOT BE IN PARTS BAG AS THEY MAY ALREADY BE ASSEMBLED. CAREFULLY CHECK PARTS AND PACKING MATERIALS PRIOR TO ORDERING REPLACEMENTS.

Tools Required for assembly: Allen Wrench (included)

WARNING: DO NOT FULLY TIGHTEN SCREWS AND BOLTS UNTIL ALL PARTS HAVE BEEN ASSEMBLED PROPERLY.  
TO PREVENT SCRATCHING THE TOP SURFACE, ASSEMBLE PRODUCT ON A SMOOTH SURFACE.  
DO NOT OVER TIGHTEN SCREWS AND BOLTS.

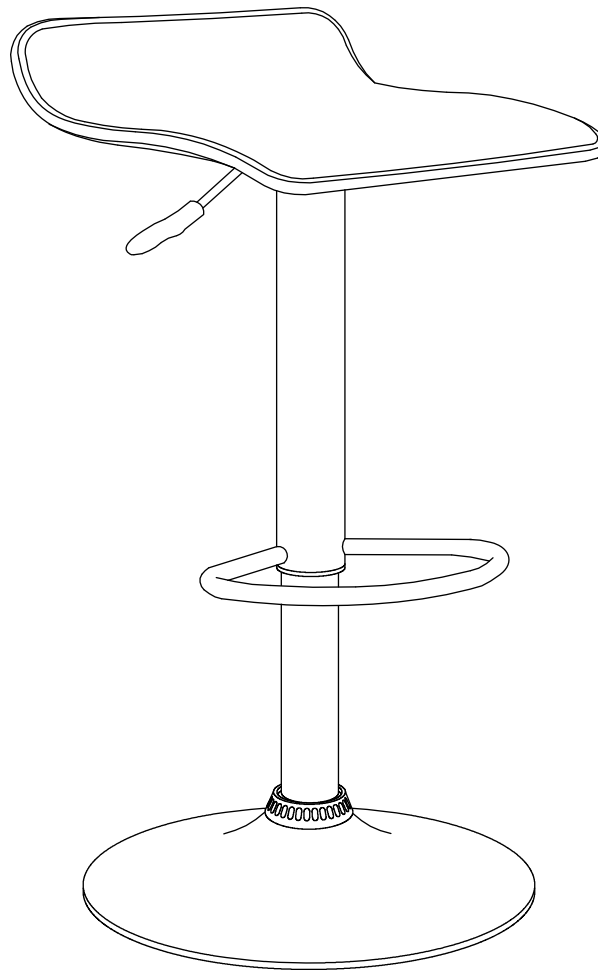

# PARTS

- (A) SEAT
- (B) UPPER POST
- (C) LOWER POST
- (D) THIMBLE
- (E) BASE

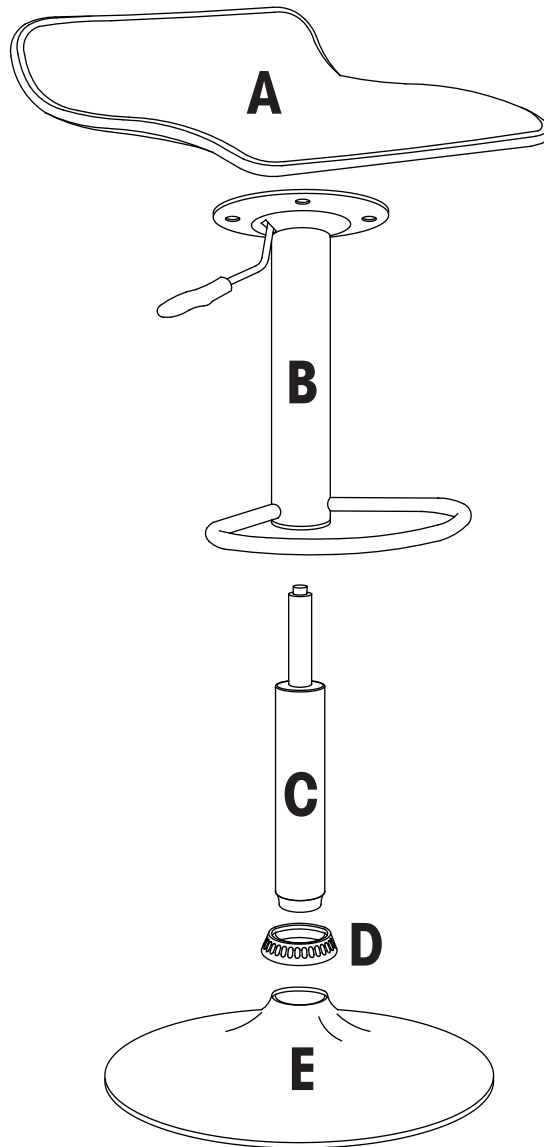

# HARDWARE

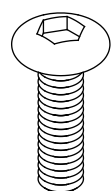

**F**  
(4PCS)

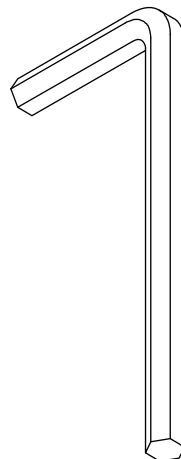

**G**  
(1PC)

**Notice: Please take off the protection cap of POST (C) before assemble.**

**STEP 1**

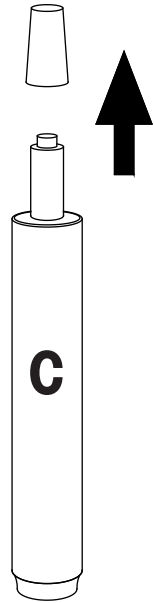

**STEP 2**

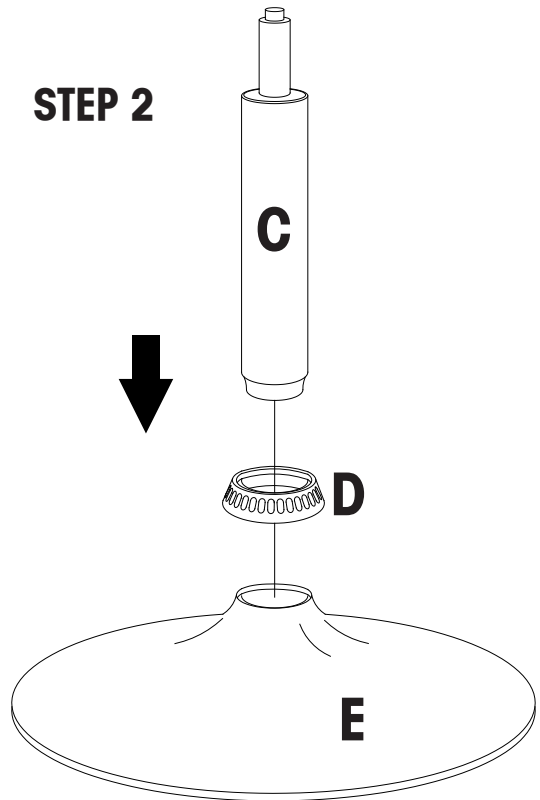

**All Parts MUST be assembled as shown and only with tools provided. Do not assemble any other way.**

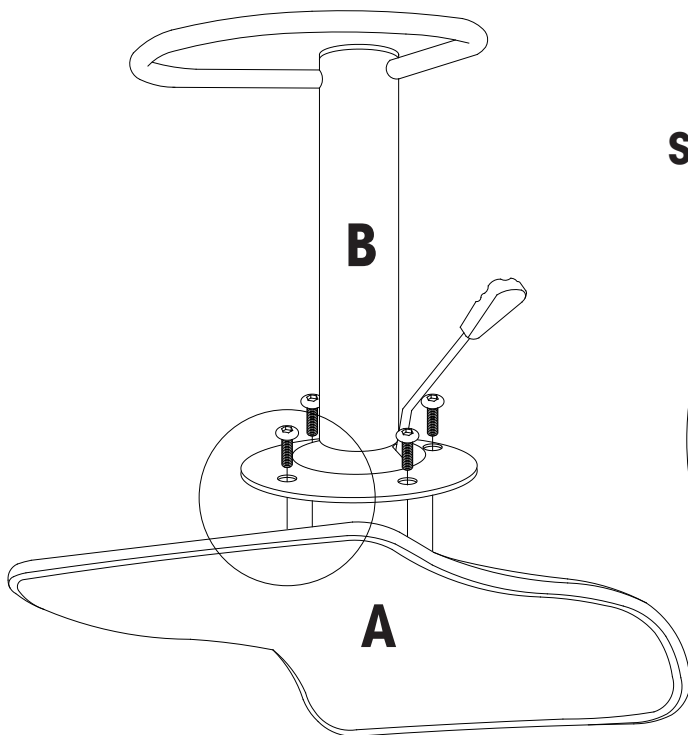

**STEP 3**

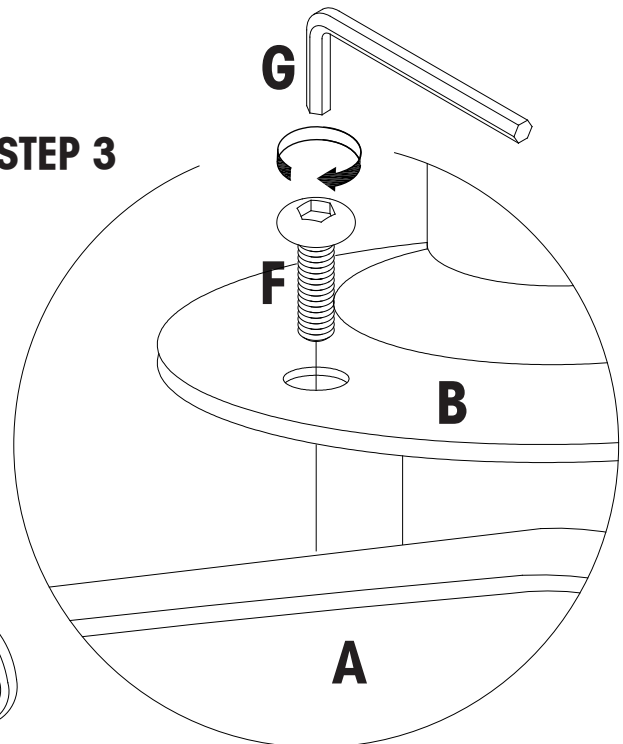

**STEP 4**

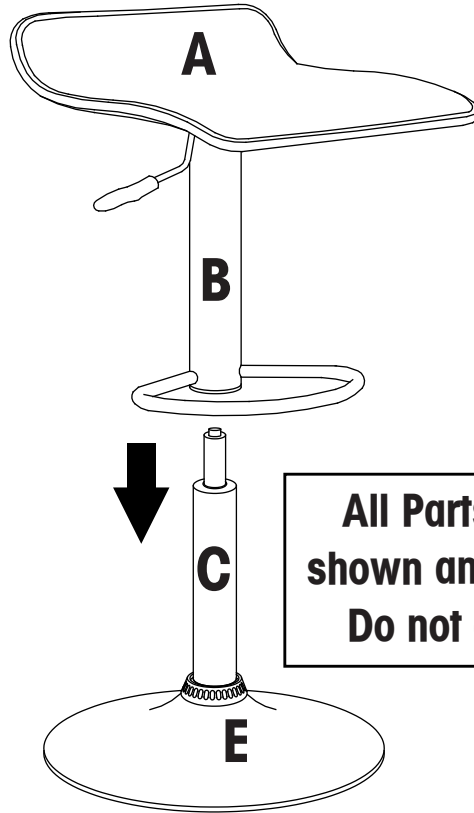

**All Parts MUST be assembled as shown and only with tools provided. Do not assemble any other way.**

**STEP 5**

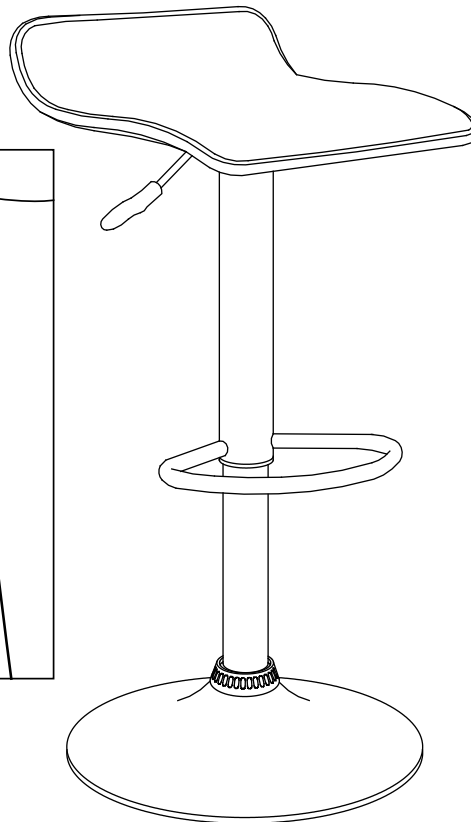
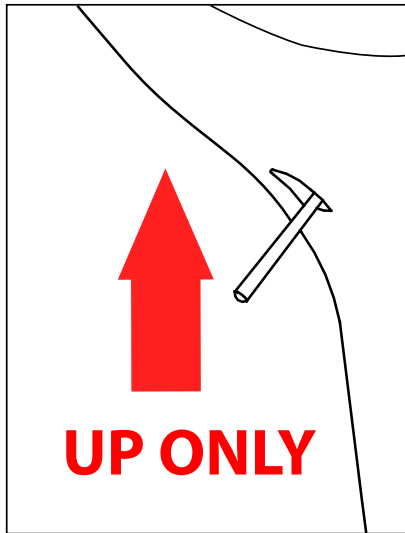

RED THIN SEAT  
WHITE THIN SEAT  
BLACK THIN SEAT