

# Installation & Assembly

## Dining Chair



# Assembly Instructions

Before beginning the assembly process, please read and save these instructions for reference.

Following these guidelines will ensure a smooth and successful assembly of your product.

## 1. Part Identification:

Carefully separate and identify all the parts included in your package. Confirm that you have all the components listed in the instruction manual. This step will help you avoid any missing or misplaced parts during assembly.

## 2. Work Surface:

To prevent any scratches or damage to the product, assemble it on a soft mat or a similar protective surface. This will provide a cushioned area for the components and protect the surfaces from unwanted marks.

## 3. Step-by-Step Assembly:

Follow the assembly instructions provided, proceeding one step at a time. Take care to understand each step properly before proceeding to the next one. This sequential approach ensures that the assembly is done correctly and minimizes the chance of errors.

## 4. Proper Screw Seating:

When attaching screws and nuts, it is essential not to fully tighten them until all screws are correctly seated. By partially tightening each screw and nut initially, you can ensure that they are aligned properly and fit securely before final tightening.

## 5. Avoid Over-Tightening:

While each screw and nut should be tightened correctly, it is crucial not to over-tighten them. Over-tightening can cause damage to the product or compromise its structural integrity. Use the appropriate amount of force to secure the components without excessive tightening.

---

## customer help center:

If you encounter any questions or problems during the assembly process, please do not hesitate to contact us.

We strive to provide excellent customer support and will respond to your inquiries within 24 hours. Our team will offer you a suitable solution to address any concerns you may have.

## Parts List

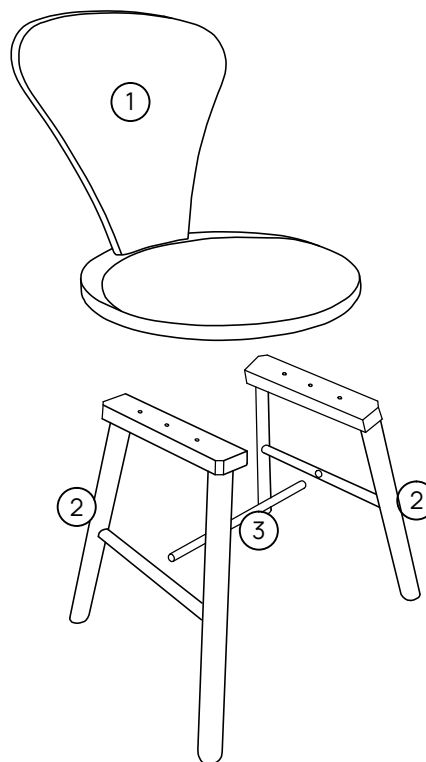

## Hardware List



AX6  
M6x35mm



BX6  
1/4"



CX6  
1/4"



DX2  
M4x32mm





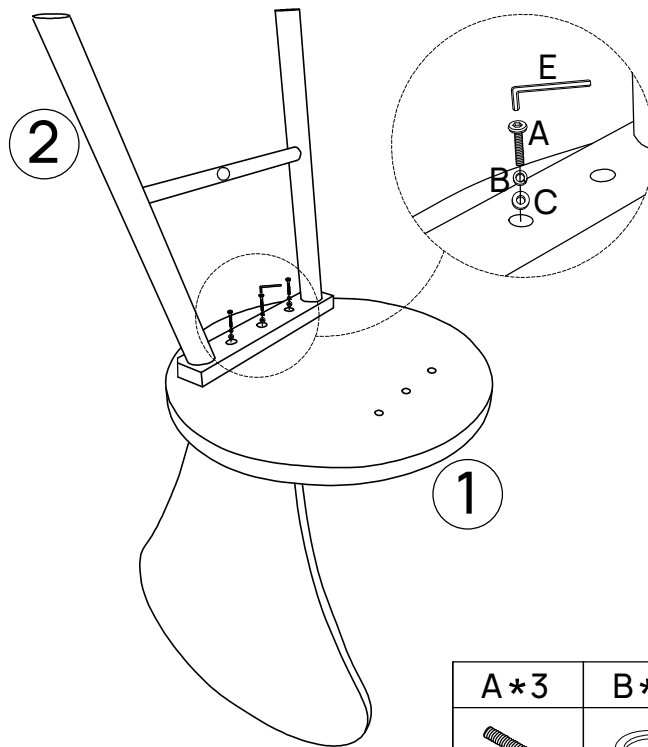

EX1  
M4

Code	Description	Quantity
A	M6x35 Jcb Screw	6+2
B	1/4" Spring Washer	6+2
C	1/4" Flat Washer	6+2
D	M4x32 Panhead screw	2+2
E	M4 Allen key	1

## Step 1







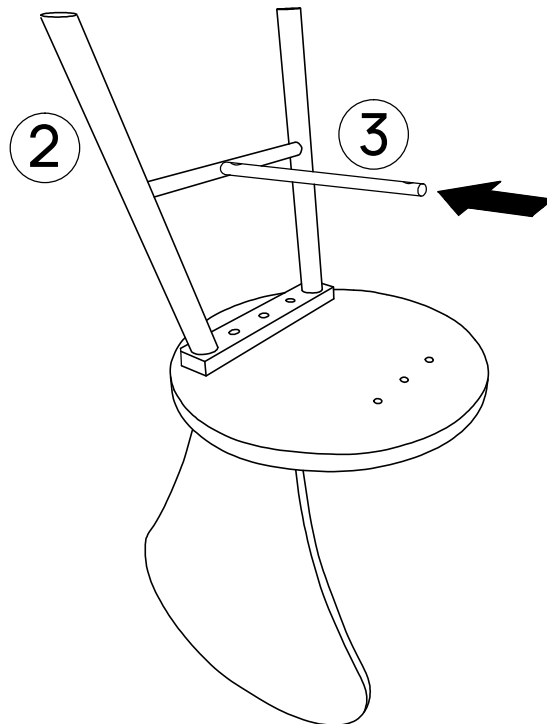

A*3	B*3	C*3	E*1
			

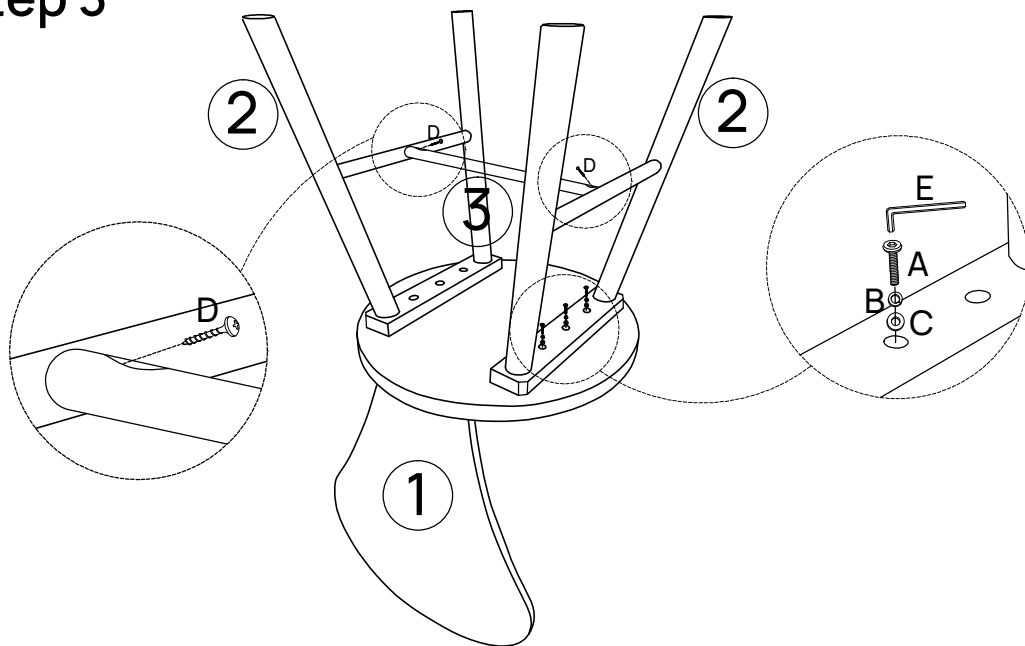
## Step 2



## Step 3



A*3	B*3	C*3	D*2	E*1
				

## Step 4

