

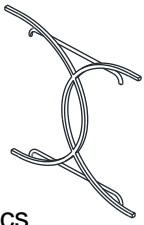

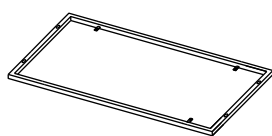
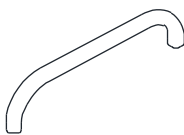
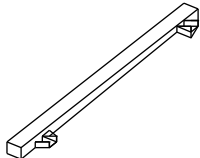
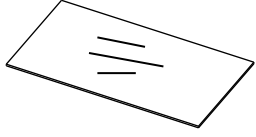
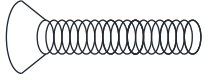
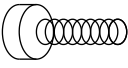
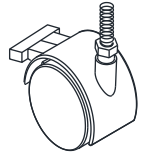
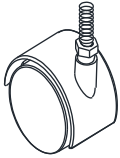
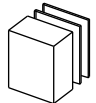
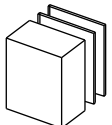

ASSEMBLY INSTRUCTION

BAR CART

A Side Panel  2pcs	B Metal Frame  2pcs	C Railing  4pcs	D Handle  2pcs
E Mirror  2pcs	F Bolt 1/4" x 1-1/8"  16pcs	G Bolt 1/4" x 3/8"  4pcs	H Caster With Brake 40mm  2pcs
I Caster Wheel 40mm  2pcs	J Small End Cap 16mm  4pcs	K Big End Cap 20mm  4pcs	L Suction Cup 8mm  8pcs
M Allen Wrench 1/4"  1pc	N Open Wrench 13mm  1pc		

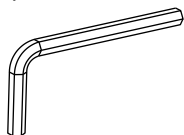

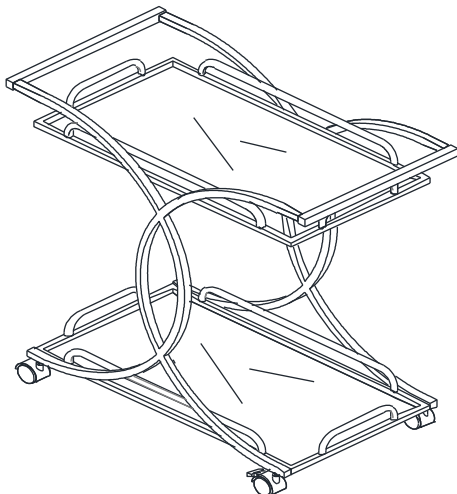
This page lists all the contents included in the box. Please take the time to identify the hardware as well as the individual components to this product. As you unpack and prepare for assembly, place the contents on a carpeted or padded area to protect them from damage.

***** Do not tighten screws & bolts until the entire unit is completely assembled.**

1

Attach Side Panel (A) to Metal Frame (B) by Bolt (F) and Allen Wrench (M) as shown.

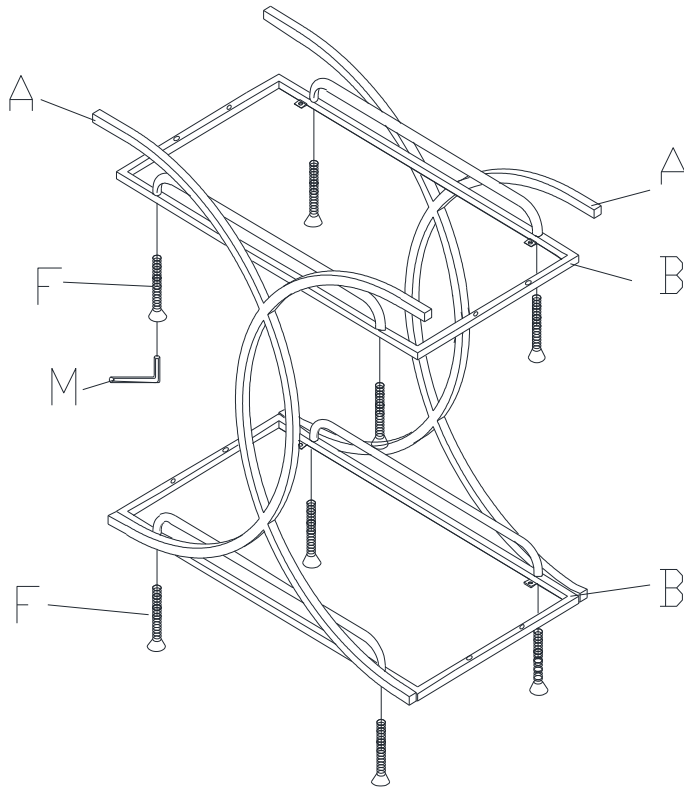

2

Attach Railing (C) to Metal Frame (B) by Bolt (F) and Allen Wrench (M) as shown.

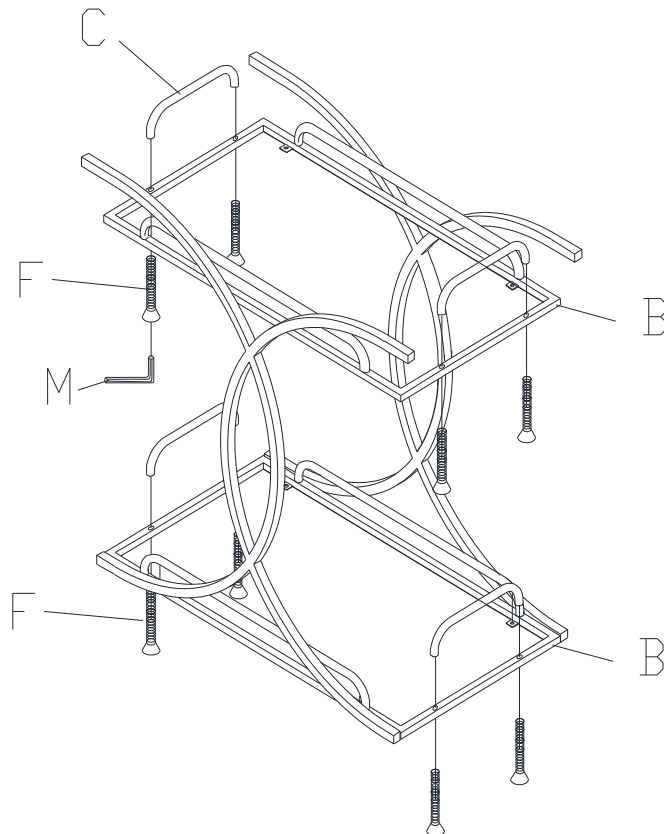

- 3** Attach Handle (D) to Side Panel (A) by Bolt (G) and Allen Wrench (M), then attach Caster (I) and Caster With Brake (H) to Side Panel (A) by Open Wrench (N) as shown.

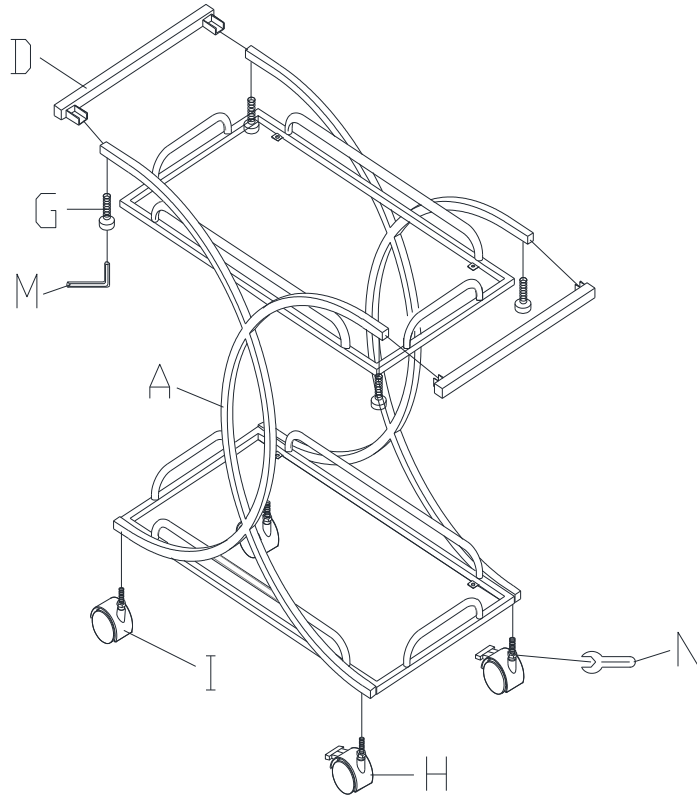

- 4** Attach Suction Cup (L) to Metal Frame (B), then attach Small End Cap (J) to Side Panel (A) as shown.

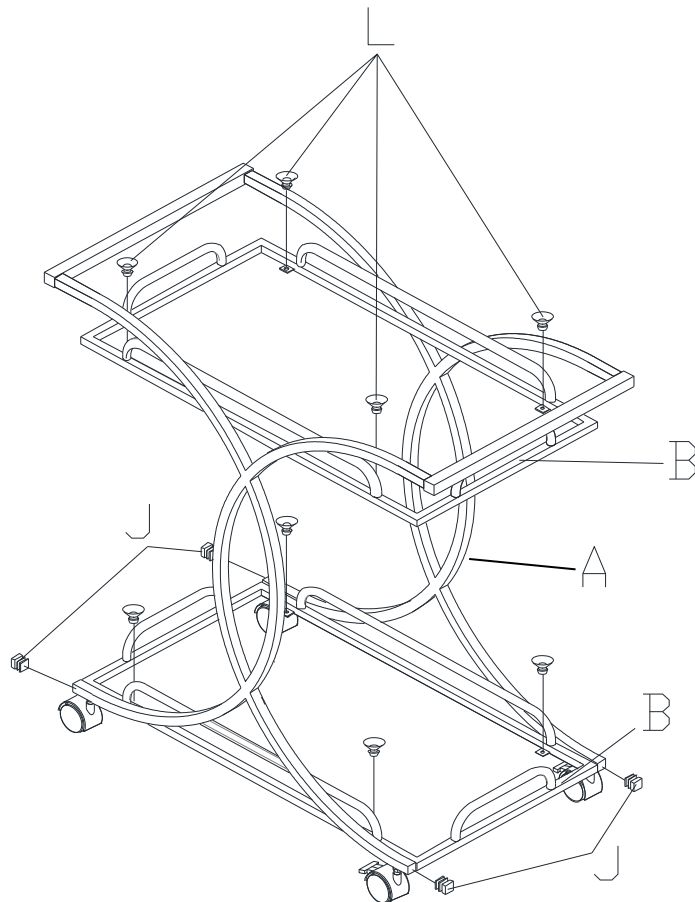

5

Attach Big End Cap (K) to Handle (D), then place Mirror (E) as shown.

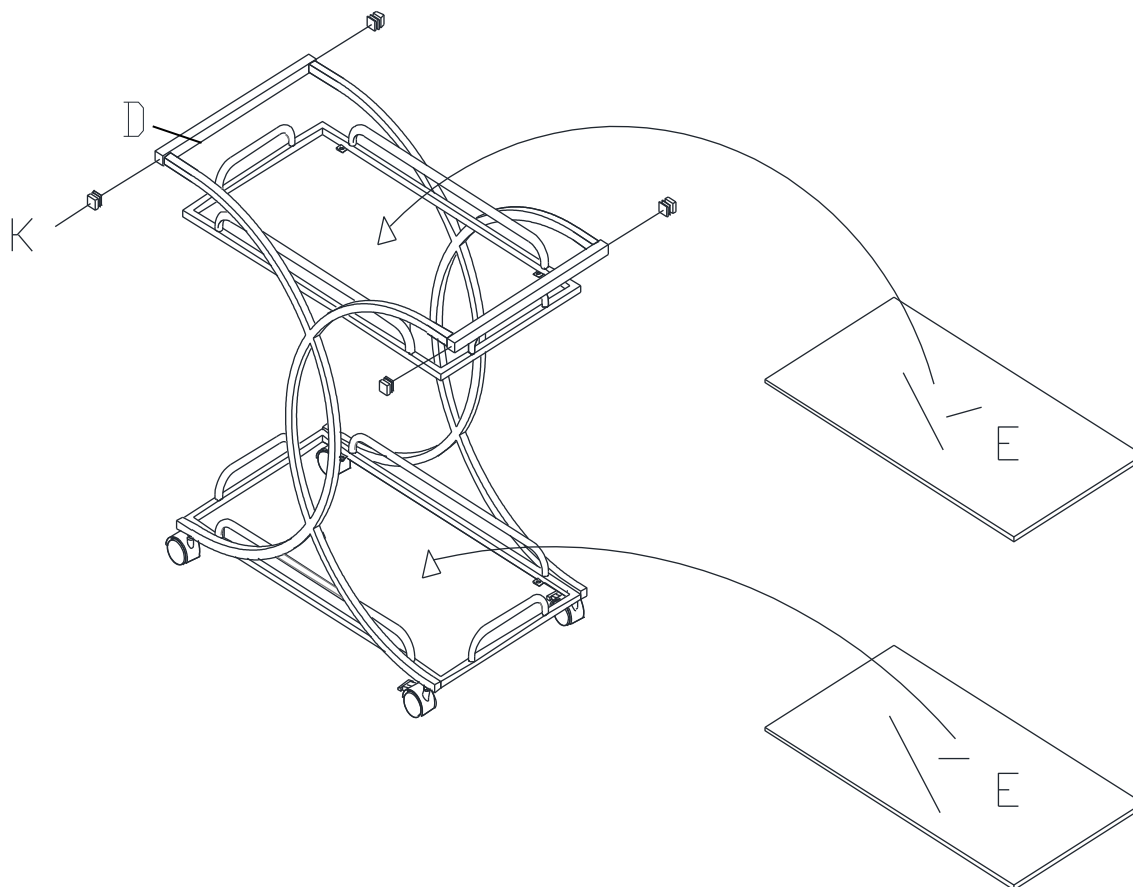

Cleaning & Care

Treat surface with care. Surface is resistant to scratches but is not scratch resistant. Clean surfaces with a dry or damp soft cloth. Do not use abrasive cleaners. Hardware may loosen over time. Periodically check that all connections are tight.