

# SINGLE-SEATING CHAIR

## ASSEMBLY INSTRUCTION

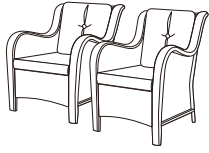

**⚠ WARNING:** This chair is not a toy. The proper use of the chair is for one-person seating only. Further, the chair is not to be used for standing purposes and it will not function as a stool or step-ladder. Besides, please use this chair on even surfaces only. Chair tested for use at a weight of 350lb. Improper use of this product or failure to use as directed may result in injury. This chair is not intended for commercial use.

### IMPORTANT:

Please read all the instructions and warnings before assembling. In order to make the whole product adjust to the best, please install all the screws on the product and tighten all the screws after adjusting the product which can stand on the floor even.

### WARNING:

- Please keep all children and pets away from the assembly area. In addition, children and pets should be supervised when they are in the area of product construction.
  - Please make sure to keep the assembly area at least 6 feet from any obstruction such as a fence, garage, house, overhanging branches, laundry line or electrical wires.
  - Some parts may contain sharp edges. Therefore, when assembling and using this product, basic safety precautions should always be followed to reduce the risk of personal injury and damage to the product. Please read all instructions before assembly and use.
  - Please check all bolts for tightness before use. IMPORTANT-check and tighten bolts often to keep them secure!
  - The chair is not to be used for standing purposes and will not function as a stool or stepladder.
- Again, this chair is used on even surfaces only.
- The chair used at the weight of 350lb. Improper use of this product or failure to use as directed may result in injury. Not intended for commercial use.

## CARE & MAINTENANCE

### SPILLS

Please immediately wipe up the spill using a white damp cloth. Repeat process if necessary until stain is gone.

### FABRIC CARE

Please use cold water and hand wash, use non-chlorine bleach when needed, lay flat to dry. Cool iron if necessary. Do not dry clean.

### PRODUCT CARE

Before using, please clean the product completely with a soft dry towel. Moreover, when the chair not in use, you should wipe off any dirt or lose objects, wash with a mild solution of soap and water, rinse thoroughly and dry completely. Please do not use strong detergent or abrasive cleaners. Since nuts and bolts can loosen over time, so please check nuts and bolts on all chairs and tables, re-tighten if necessary.

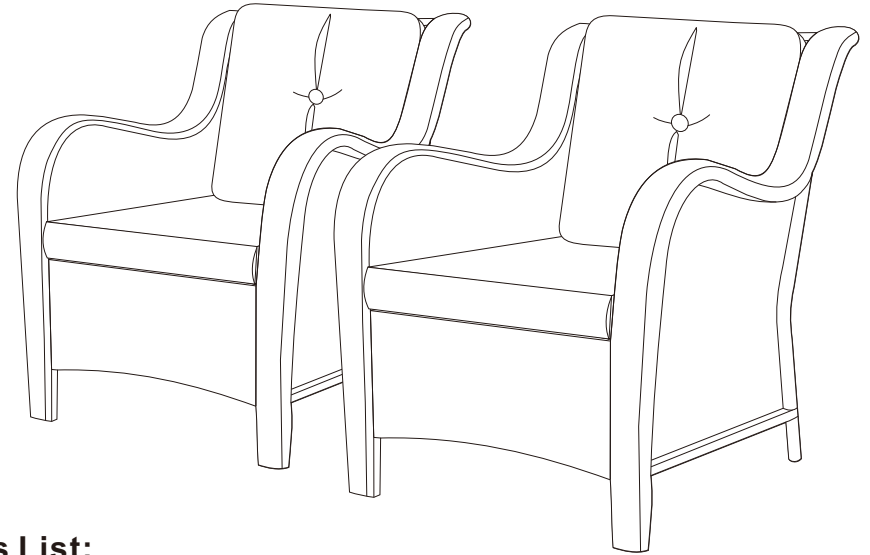

### Parts List:

NO.	Part	Qty	Image	NO.	Part	Qty	Image
①	Left arm	2		②	Right arm	2	
③	Chair back	2		④	Seat Panel	2	
⑳	Back Cushion	2		㉑	Seat Cushion	2	
A	Screw (6x40mm)	8		C	Screw (6x20mm)	12	
L	Allen wrench	1					

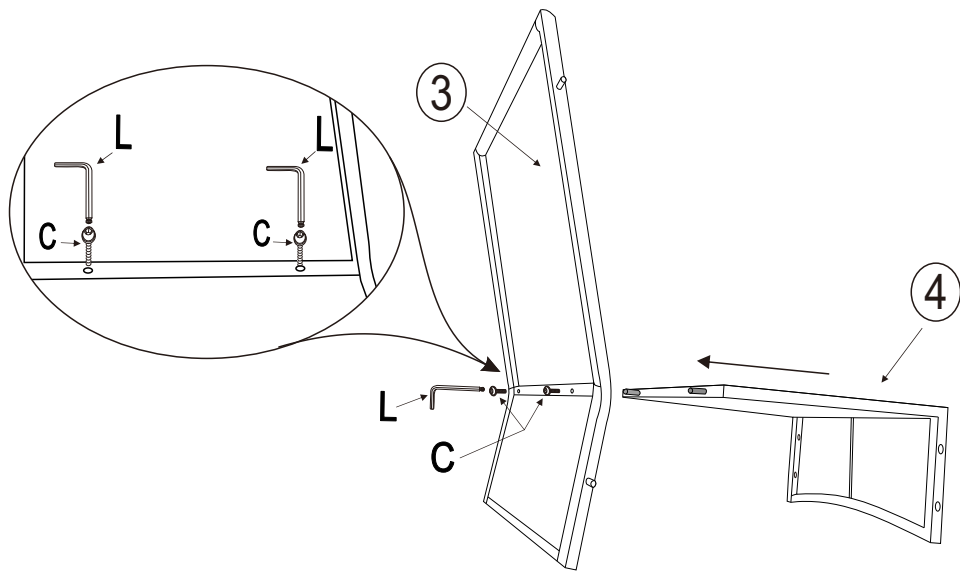

Step 1: Insert seat panel (4) into the two holes on chair back (3), then secure them with 2 screws (C) by using allen wrench (L). Do not tighten all screws now.

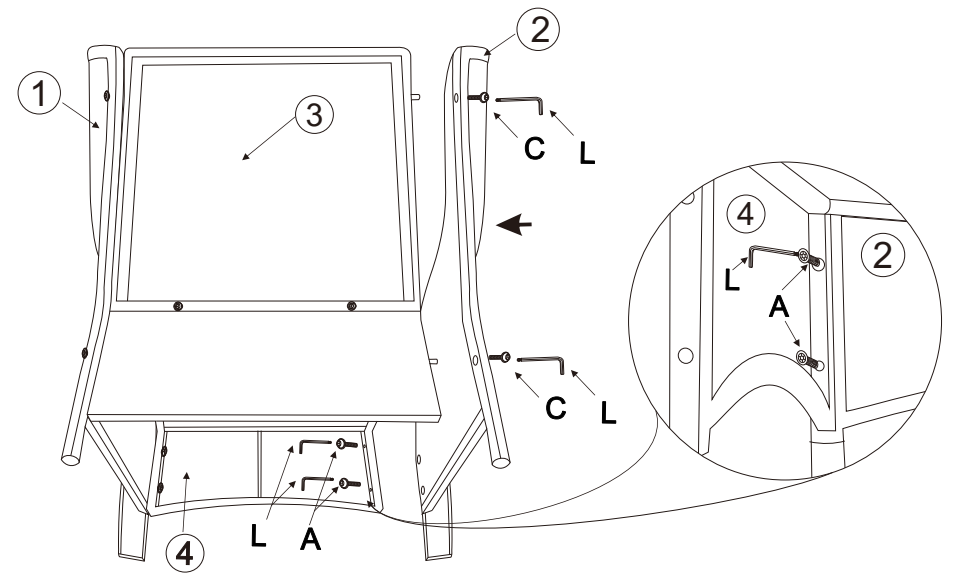

Step 3: Secure right arm (2) to assembled chair back (3) with 2 screws (C) by using allen wrench (L). Then, secure seat panel (4) to assembled right arm (2) with 2 screws (A) by using allen wrench (L). Do not fully tighten now.

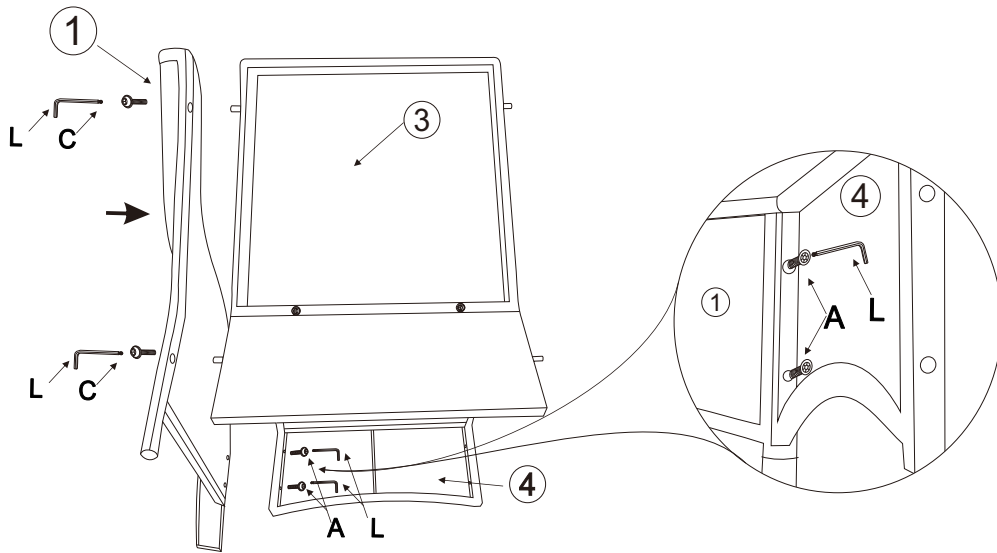

Step 2: Secure left arm (1) to assembled chair back (3) with 2 screws (C) by using allen wrench (L). Do not tighten all screws now. Then, secure seat panel (4) to assembled left arm (1) with 2 screws (A) by using allen wrench (L). Do not fully tighten now.

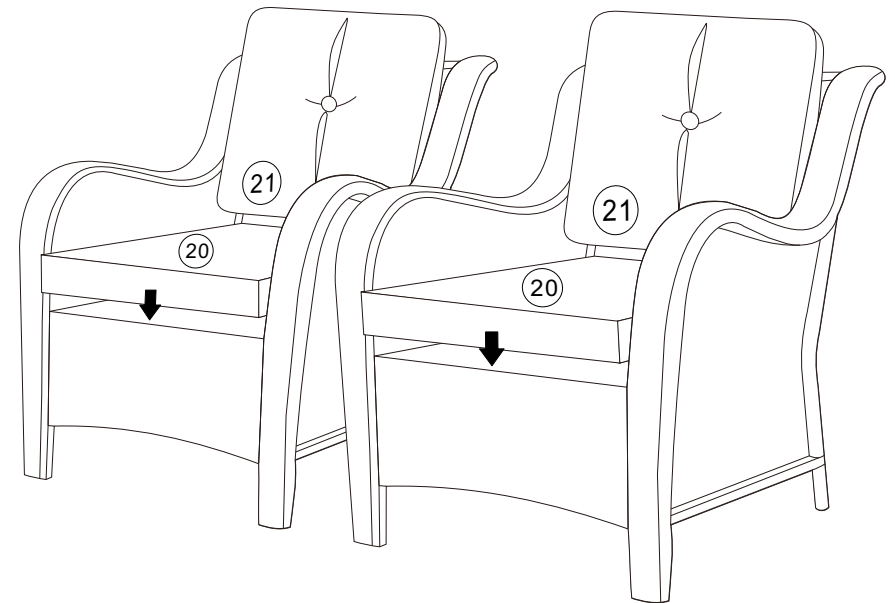

STEP 4: Please verify the alignment and adjust, fully tighten all the screws now. Then put seat cushion (20) and back cushion (21) on the chair. Continue to install another chair using the same steps, then you will finish with two chairs.