

Console Table

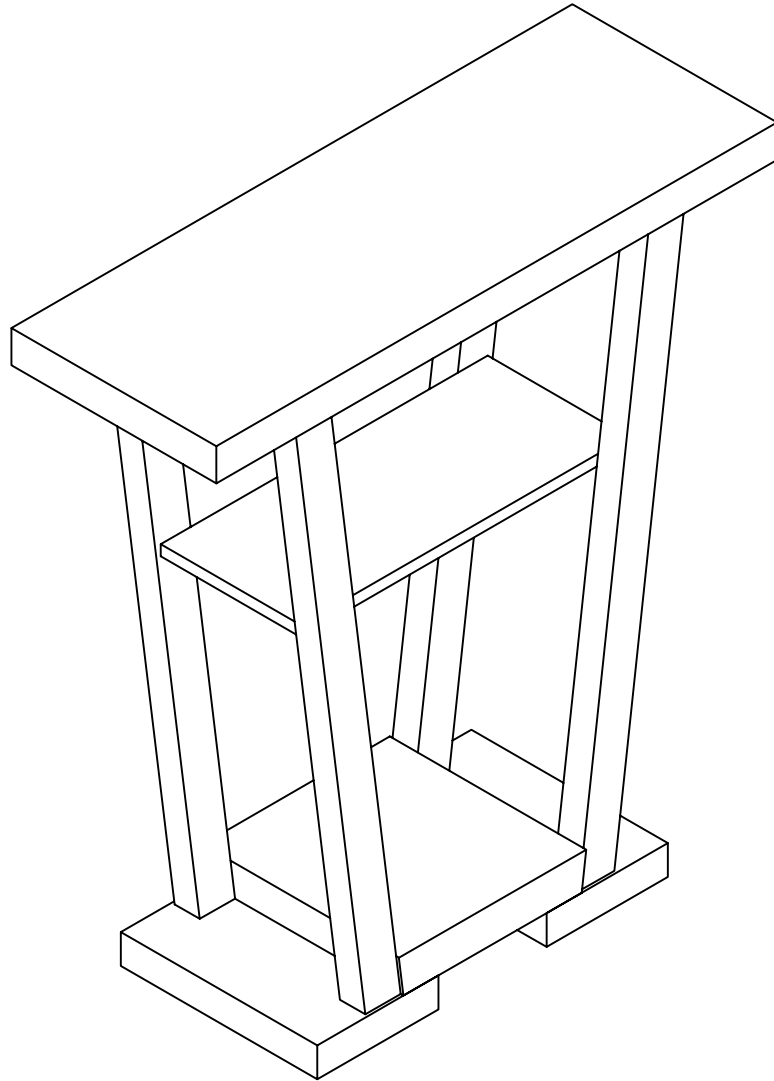

Assembly Instructions

We have designed our furniture with you, the customer in mind. Our clear, easy to follow, step by step instructions will guide you through the project from start to finish. Feel confident that this will be a fun and rewarding project. The final product will be a quality piece of furniture that will go together smoothly and give years of enjoyment.



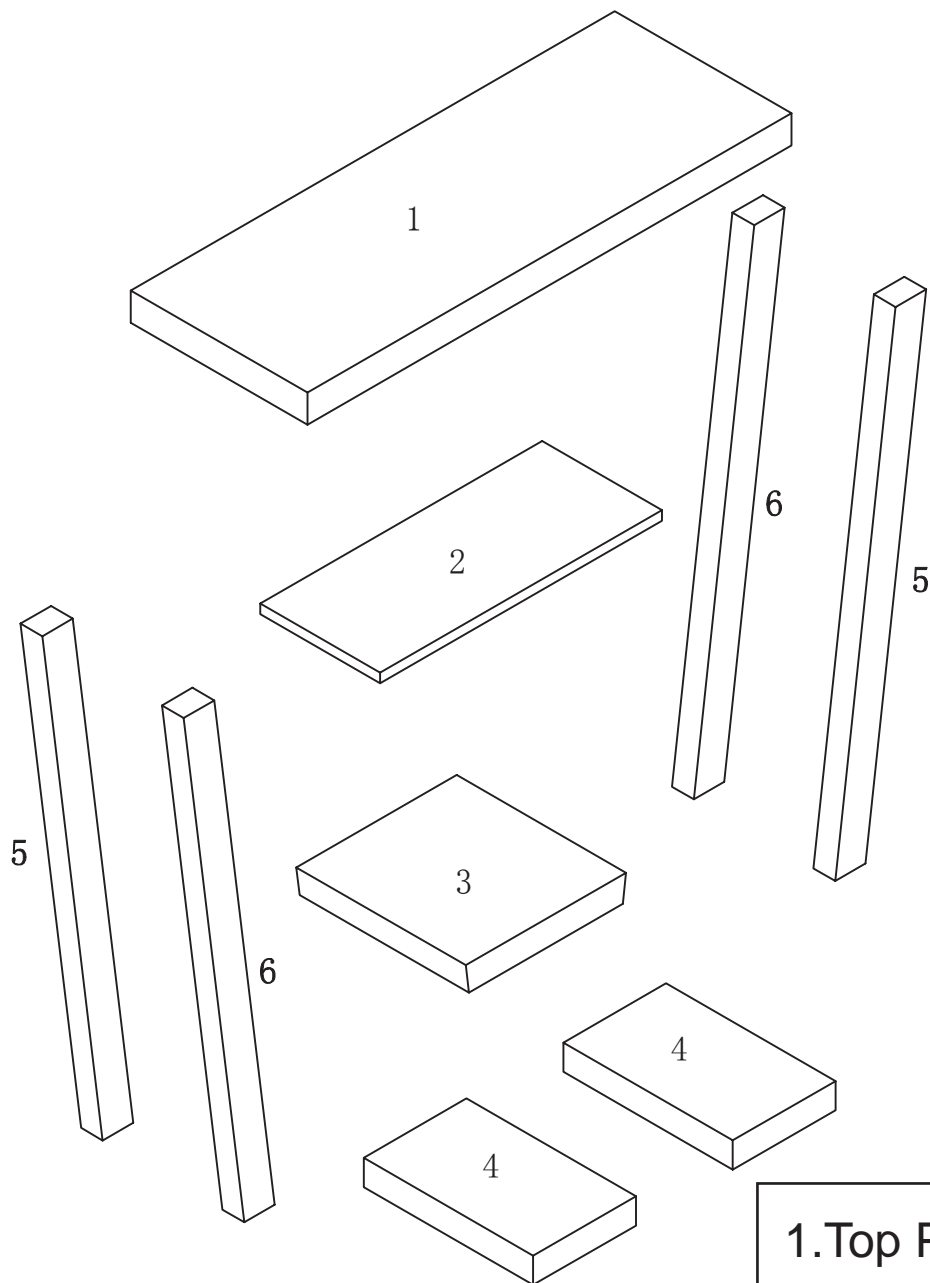



PARTS IDENTIFICATION



Please count and verify all parts before assembly

- | | |
|----------------|--------|
| 1.Top Panel | (1pc) |
| 2.Middle Panel | (1pc) |
| 3.Lower Panel | (1pc) |
| 4.Foot | (2pcs) |
| 5.Back Leg | (2pcs) |
| 6.Front Leg | (2pcs) |

HARDWARE IDENTIFICATION

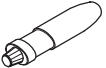
A		Cambolt	L29	4pcs
B		Camlock	ø15	4pcs
C		Dowel	ø8×25	2pcs
D		Large Screw	ø7×48	4pcs
E		Small Screw	ø3×14 (BK)	16pcs
F		Medium Screw	ø4×40	4pcs
G		Threaded Rod	M8×65	4pcs
H		Jam Washer & Nut ^{M8}		4sets
I		Wrench	M13	1pc
J		Sticker	ø45	4pcs
K		Bracket	28×20×20(BK)	4pcs
L		Glue	Glue: For securing please apply to wood dowel first before inserting into panel	1pc

Assembling the unit with camlocks and wood dowels.

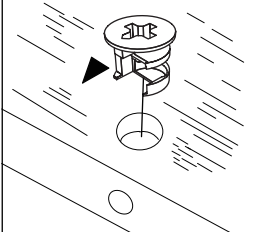
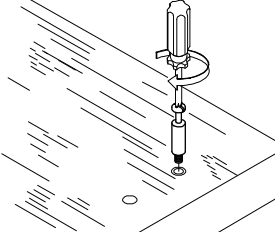
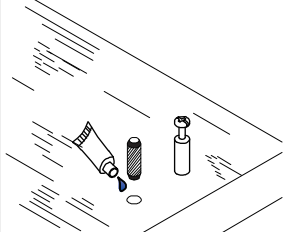
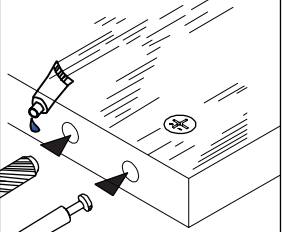
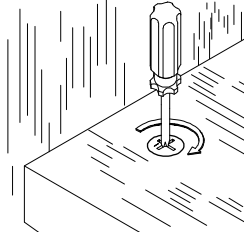
				
Insert camlock, camlock must face bolt hole	Gently screw cam anchor into the threaded anchor	Lightly glue one end of wood dowel and tap into hole.	Lightly glue dowel and connect to second panel by inserting dowels into holes	Gently screw the cam clockwise into locked position. Do not overtighten.

Step1

1. Attach camlock hardware to lower panel (3) and Leg (5)&(6).

2. Assemble pieces as shown, gently tighten camlocks.

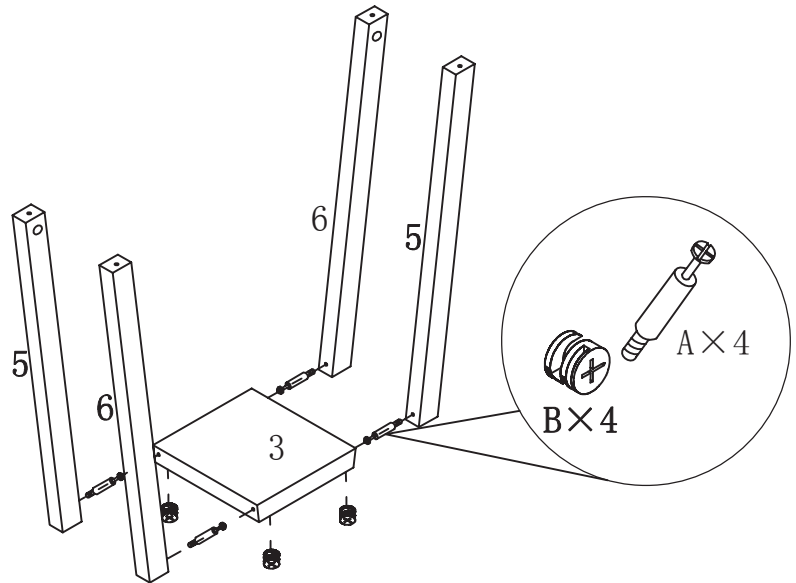

NOTE:

*REFER TO PAGE3 FOR CAMLOCK ASSEMBLY.

Step2

Turn unit upside down and fasten feet (4) to unit with dowels (C), large screws (D) and medium screw (F).

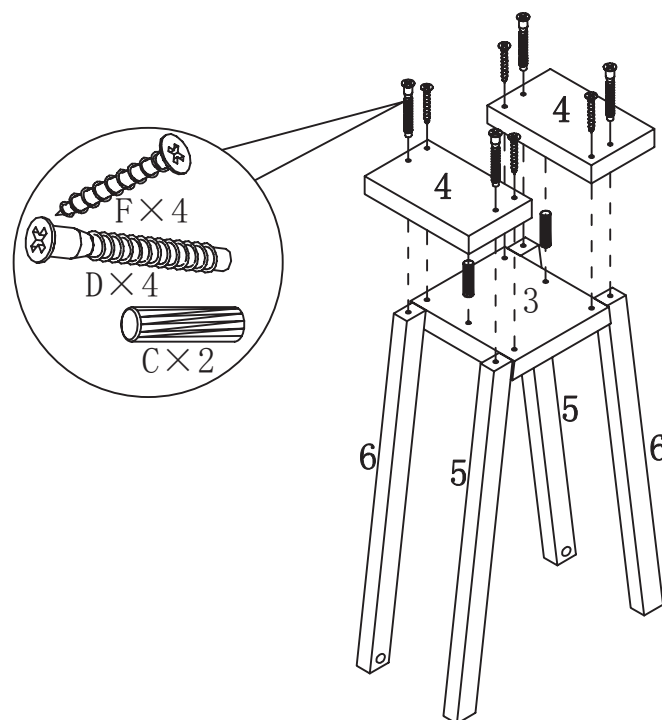

Step3

1. Turn unit right side up.
2. Using your hand, firmly screw threaded rods (G) into top panel (1) .
3. Insert jam washer & nut (H) into slots in legs with nut below washer.
4. Carefully place top panel (1) onto unit.
5. Using wrench (I) carefully tighten jam nut & washer (H).

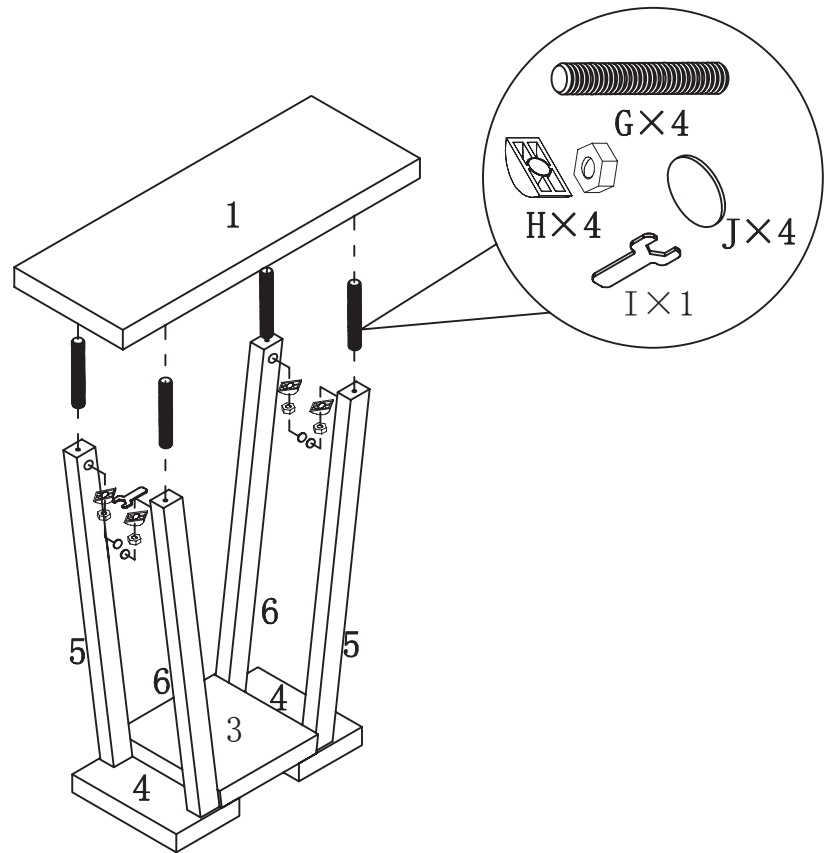

Step4

Attach bracket (K) to middle panel (2) using small screws (E) as shown.

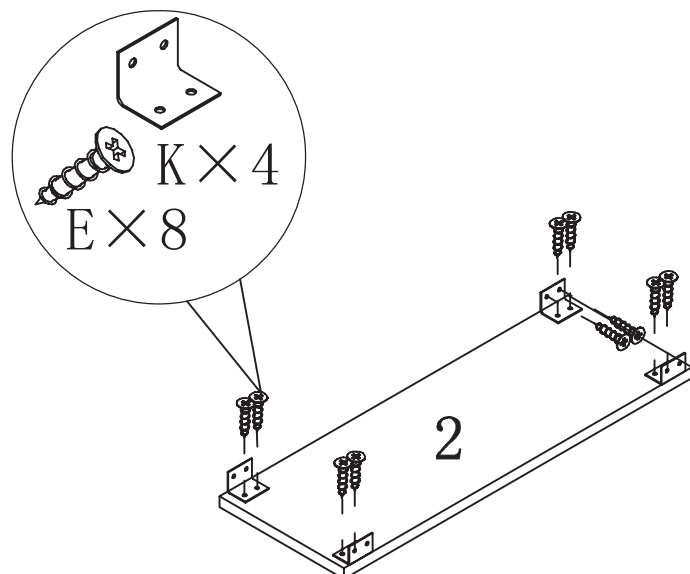

Step5

1. Using a slight angle, carefully place middle panel (2) into unit as shown.

2. Secure middle panel (2) to unit with small screws (E).

3. Cover any screw holes with stickers.

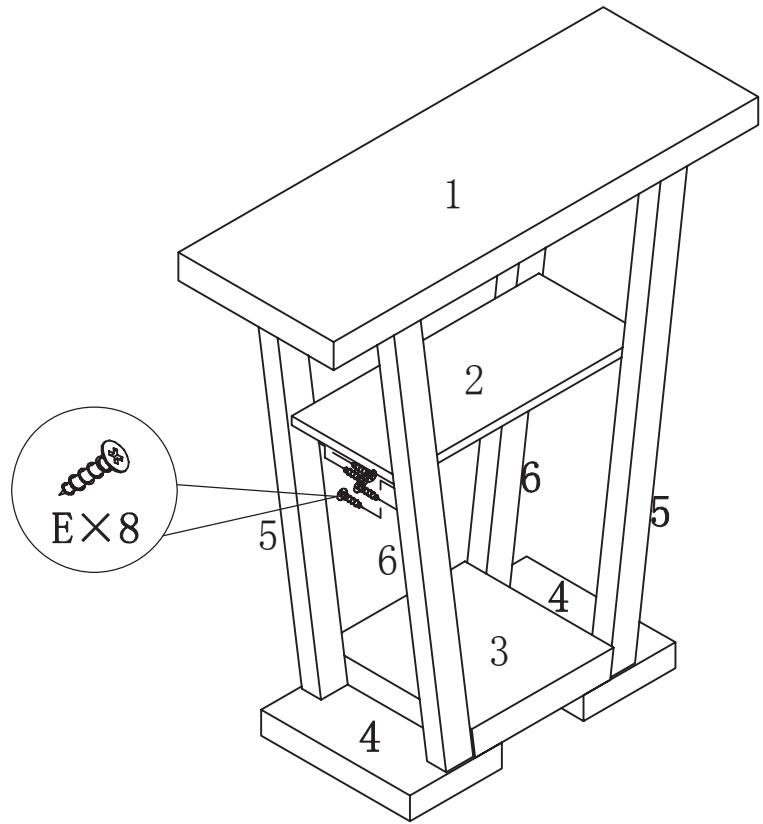

Enjoy your new console table!

