

HAPPINESS HAPPINESS INSTALLATION



CAUTION

Parts are placed at the bottom of the product.

- If you have any questions with the product, please contact us by:
- **Email: customerservice@zoy-living.com**
(we will reply to you within 24 hours)

Assembly Instructions

Model: C R 0 3 4 6 A

CAUTION

DO NOT use any sharp objects to open plastic wrapped components as this may result damage to product or components .

Your recliner comes packaged in **One** box. Carefully remove all of components from the packaging and setaside for assembly.

Package Contents

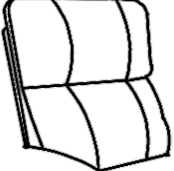
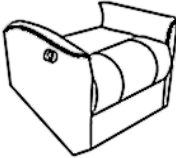
BOX 1 CR0346AF71D				
	A*1	B*1		

1 RECLINER ASSEMBLY - BODY SETUP

Step1 :

Put out all the parts from carton and check the parts are complete and undamaged according to the above fitting list. Then cut the cord that fixes the base of **Seat(B)**.

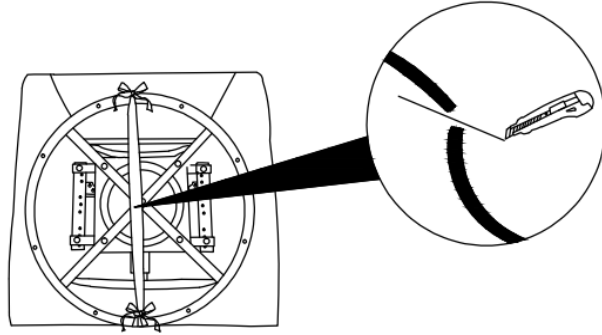

Step2 :

Install the **Chair Back (A)** on the **Seat (B)** via slot to ensure a tight connection without wobbling.

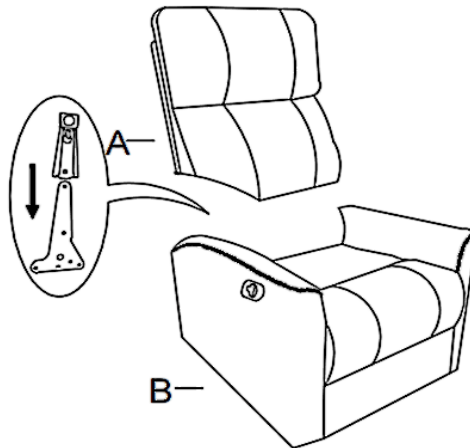

ASSEMBLY COMPLETED

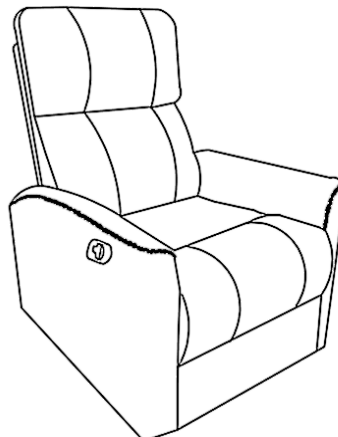

2 INSTRUCTIONS FOR USE - SIZE DIMENSIONS

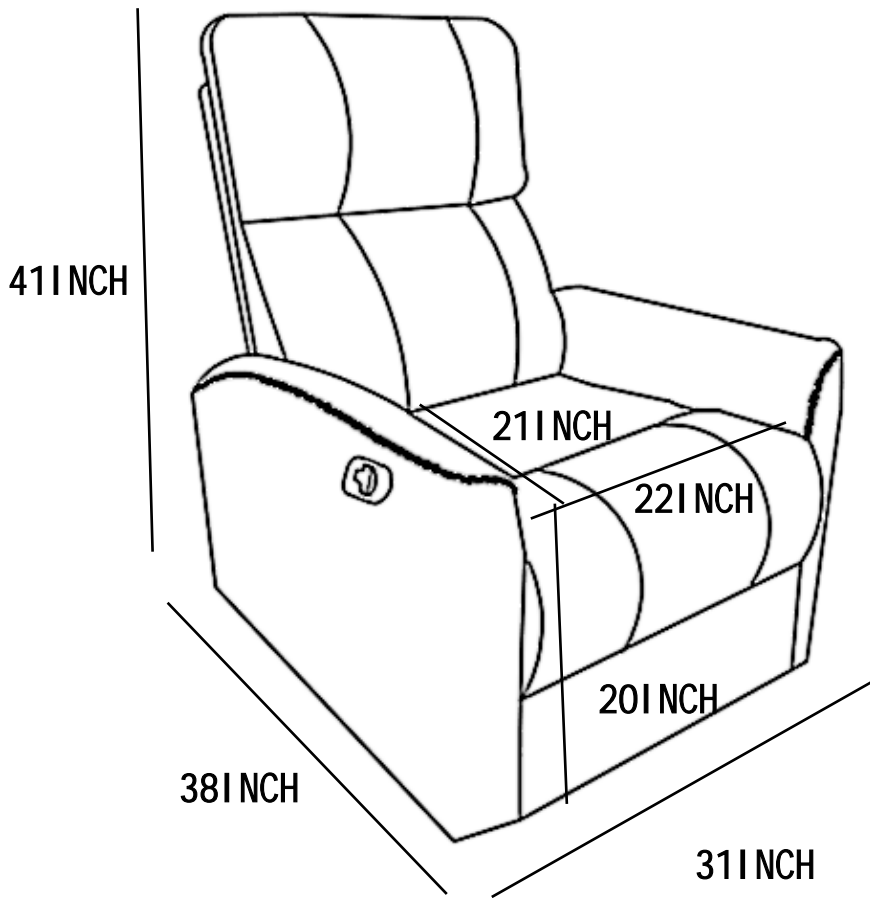

Recliner

CR0346AF71D

⚠️ WARNINGS

1. Please check if the components of the chair are all included and can be used normally.
2. Assemble all components according to the instruction correctly before you connect the chair to the power.
3. Please DO NOT sit on the armrests or footrest to eliminate the risk of tipping over.
4. If the chair is damaged or doesn't match the website description, please send clear pictures of the product and label of the carton to our service team for further help.
5. If the recliner doesn't work, you may try the following measures for self-checking firstly:
 - a) check if all the cables are connected;
 - b) check if the light of transformer is on.

If the chair still doesn't work, please feed the information back to our customer service in time and we will help you solve the matter as soon as possible.

6. If you have any questions about our products, please contact us by:

Email: customerservice@zoy-living.com (we will respond to your inquiry within 24 hours)

