

TRIPOD COOKING GRATE

Review all assembly and care information before using this product.

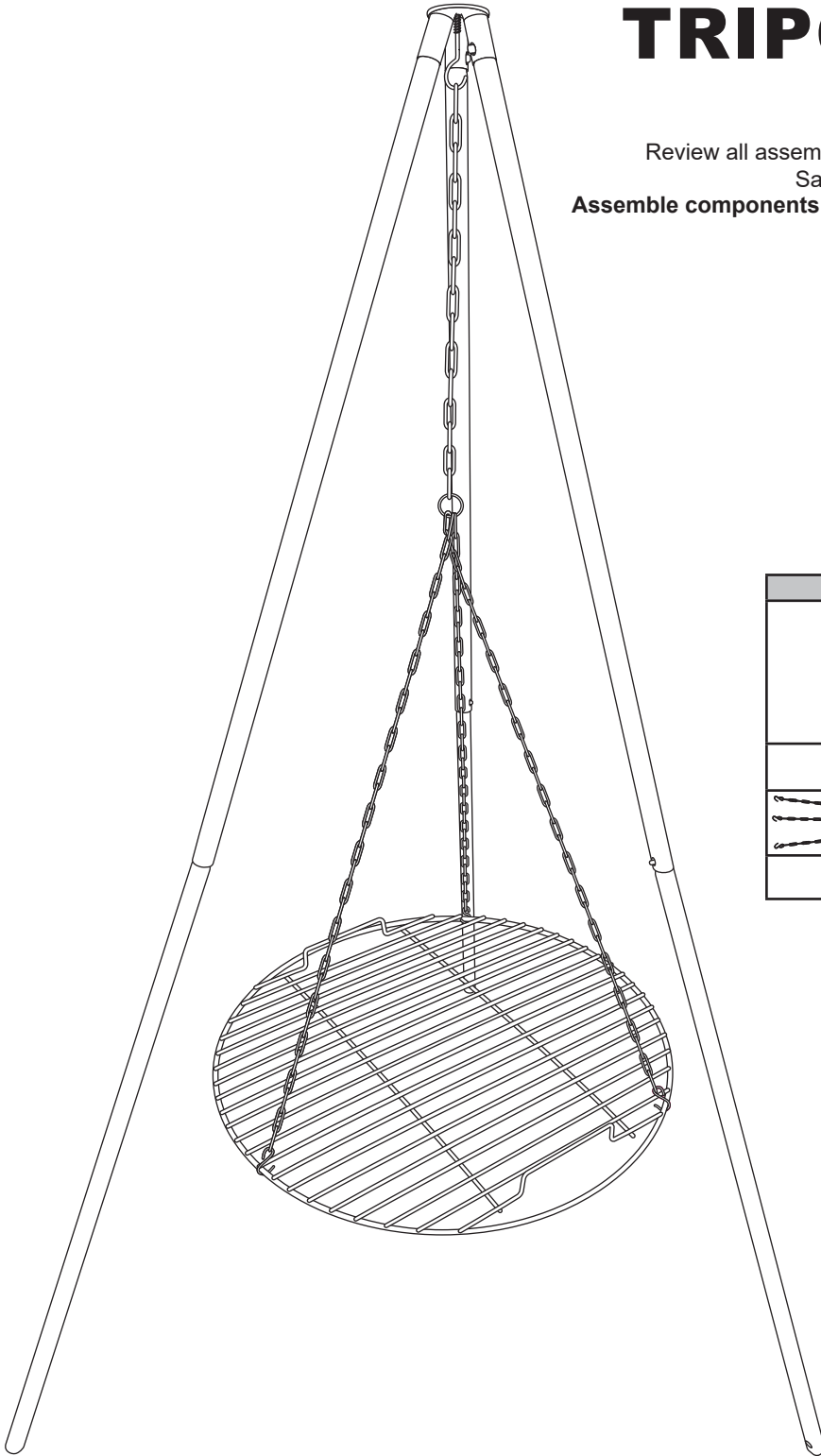



Save this manual for future reference.

Assemble components on a soft, clean surface to avoid damaging the finish.

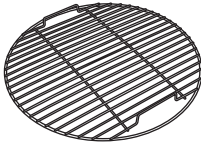

Inspect packaging to ensure all parts are accounted for before disposing of packing materials.

 Save the packing slip.

PARTS		QTY.
	Cooking Grate	1
	Tripod Top	1
	Chain	1
	Tripod Pole	6



Cooking Grate
Weight Capacity

WARNING:

Manufacturer and seller expressly disclaim any and all liability from personal injury, property damage or loss, whether direct or indirect, or incidental, resulting from the incorrect attachment, improper use, inadequate maintenance, or neglect of this product.

ASSEMBLY

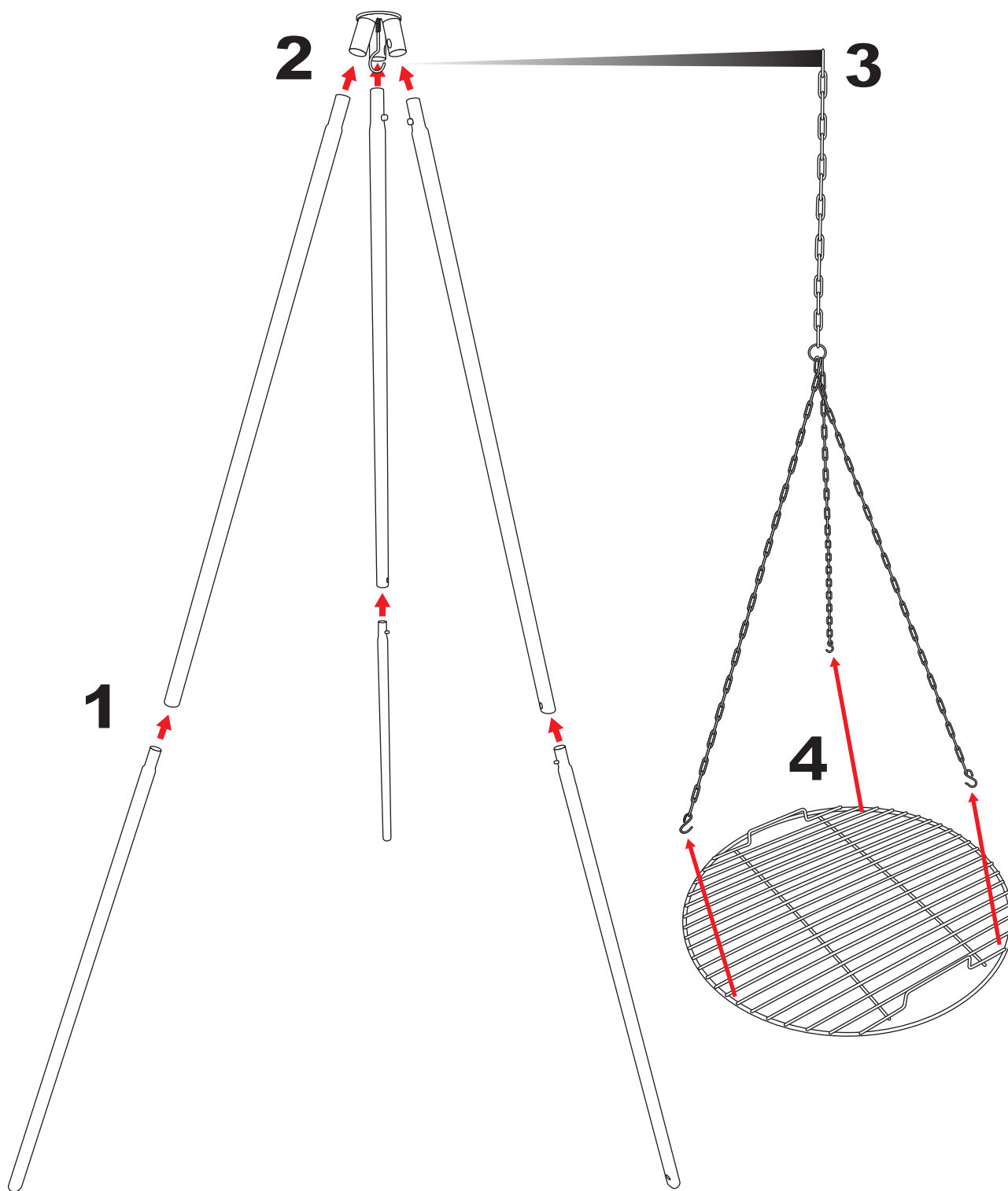

1. Connect two pole sections together to create a tripod leg. Repeat this process two more times for a total of three tripod legs.
2. Connect the tripod poles to the tripod top.
3. Identify the chain without a hook attached, hang it on the tripod hook.
4. Ensuring the chains are evenly spread out, hang the cooking grate on the chain hooks.

CARE & MAINTENANCE

SAFE USE: Follow all safety statements and warnings.

Only use on a flat, level surface.

Do not move the grill during use.

This product is only to be used by adults with developed comprehension and motor skills.

The cooking grate will become extremely hot while in use. Always use heat-resistant gloves and utensils when cooking with this product.

Assistance may be required to hold the cooking grate steady while flipping and moving food on the cooking grate. Ensure weight is evenly distributed; improper weight distribution may cause the grate to tip and/or slip off the hooks.

CLEANING: Clean the grilling grate after each use. The grate must be completely cool before cleaning; if you feel heat when your hand is close to the metal, it is too hot to clean. Use warm water, mild detergent, and a medium-bristled scrub brush to clean the grate. Dry with a soft, clean towel.

EXPOSURE & MAINTENANCE: Limit exposure to precipitation and high moisture as it may cause the non-coated surfaces to rust. Cover or store indoors when not in use. Store in a cool, dry location. Ensure the unit is completely cool and cleaned before storing. Manufacturer is not liable for damage resulting from general use, misuse, and/or environmental conditions.

SCRATCHES: The powder coating on the tripod is tough and durable, but even under normal use, some scratching is inevitable. To avoid excessive rust, wipe scratched areas as needed to remove moisture.

WARNING: THE ONE-YEAR WARRANTY DOES NOT COVER DAMAGES OR DEFECTS CAUSED BY THE APPLICATION OF CHEMICAL TREATMENTS, PROTECTIVE COATINGS, TOUCH-UP PAINT, OR CLEANING PRODUCTS.

SAFETY STATEMENTS & WARNINGS

- For outdoor use only. Never use this product in an enclosed area.
- Do not exceed the weight capacity of the cooking grate.
- Always follow local laws and regulations when using fire pits.
- Exercise the same care and precautions as you would with an open fire.
- Always supervise children and pets when they are in proximity of this product, whether it is in use or not in use.
- Never use any fire pit during dry or windy conditions.
- Keep this unit a safe distance away from buildings, balconies, or overhangs when in use.
- Do not use on or near combustible surfaces or structures such as wood decks, dry leaves or grass, mulch, vinyl or wood siding, etc.
- Only use this unit on a level, non-combustible surface.
- Keep away from all combustible materials including gasoline and other flammable liquids and vapors.
- Never use accelerants such as, but not limited to, gasoline, alcohol, paint thinners, kerosene, as this may cause serious injury or product damage.
- This unit becomes very hot when in use. Ensure the unit is completely cool before cleaning or moving.
- Never leave unit unattended while hot or in use.
- Extinguish the fire properly before leaving the unit unattended. If necessary, use a fire extinguisher or sand to smother the fire. NEVER use water to extinguish hot fires or embers as doing so may cause serious injury and/or permanently damage the product.
- Ensure the unit is completely cool before covering, failure to do so will damage the cover and the unit.
- DO NOT USE CHEMICAL-BASED CLEANERS as this may damage the product and/or ignite a flame during the next use.
- Contact the local authorities regarding possible burn restrictions before using this product.

Any modification to the product or failure to follow recommended care will void the product warranty.

If you experience issues with assembly or the product was damaged during transit, please contact our customer service team through one of the methods mentioned at the top of page 1. Please have the item number and order information ready to expedite response time.

WARNING:

Manufacturer and seller expressly disclaim any and all liability from personal injury, property damage or loss, whether direct or indirect, or incidental, resulting from the incorrect attachment, improper use, inadequate maintenance, or neglect of this product.