

# Installation Instruction

SKU: N606P434436/N606P434437

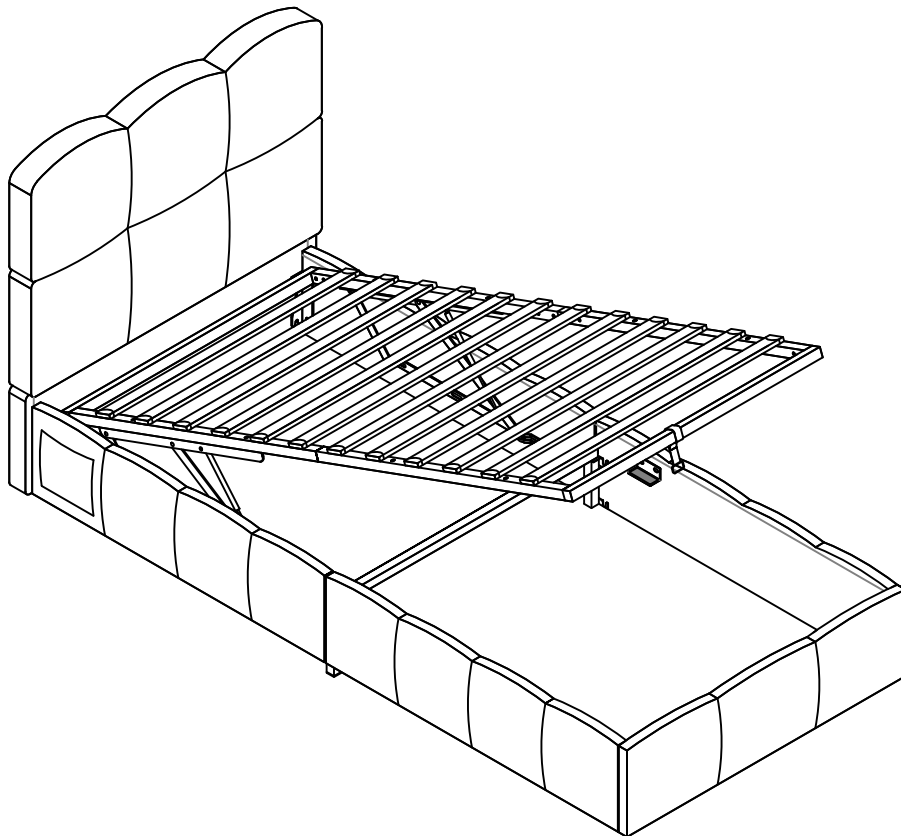

UK:Our product will be delivered to you in 2 packages. The delivery times of these 2 packages may differ, please be patient and thank you for your understanding.

**UK  
CA**



## English

### IMPORTANT FOR GAS LIFT BEDS&MAINTAINCE

- Please place the mattress on top of the bed frame.
- Please do not pull on the strap handles.
- Please press heavily to release the compressed gas.
- Periodically check all screw & fixings to ensure they are secure.
- When moving your product, carefully lift into place.
- Wipe clean with a slightly damp cloth- please do not use abrasive chemicals or bleach.
- Do NOT allow children to operate the lift mechanism.
- Do NOT allow children near the lift base when operating the mechanism.
- Do NOT stand inside the bed or the internal storage base.
- Do NOT overload the internal storage base.
- DO NOT jump on the product or any of its parts.

## Deutsch

### WICHTIG FÜR GASLIFT-BETTEN&WARTUNG

- Bitte legen Sie die Matratze oben auf den Bettrahmen.
- Bitte ziehen Sie nicht an den Gurtgriffen.
- Bitte drücken Sie kräftig, um das komprimierte Gas freizusetzen.
- Überprüfen Sie regelmäßig alle Schrauben und Befestigungen, um sicherzustellen, dass sie sicher sind.
- Wenn Sie Ihr Produkt bewegen, heben Sie es vorsichtig an seinen Platz.
- Mit einem leicht feuchten Tuch abwischen - bitte keine scheuernden Chemikalien oder Bleichmittel verwenden.
- Erlauben Sie Kindern NICHT, den Hebemechanismus zu bedienen.
- Lassen Sie Kinder NICHT in die Nähe des Liftsockels, wenn Sie den Mechanismus bedienen.
- Stellen Sie sich NICHT in das Bett oder in die Innenablage.
- Überlasten Sie den internen Liftsockel NICHT.
- Springen Sie NICHT auf das Produkt oder eines seiner Teile.

## Français

### IMPORTANT POUR LES LITS À RELEVAGE DE GAZ&MAINTENANCE

- Veuillez placer le matelas sur le dessus du cadre de lit.
- Ne tirez pas sur les poignées de la sangle.
- Appuyez fortement pour libérer le gaz comprimé.
- Vérifiez régulièrement que toutes les vis et fixations sont bien en place.
- Lorsque vous déplacez votre produit, soulevez-le avec précaution pour le mettre en place.
- Nettoyez avec un chiffon légèrement humide - n'utilisez pas de produits chimiques abrasifs ou d'eau de Javel.
- Ne laissez pas les enfants utiliser le mécanisme de levage.
- Ne laissez pas les enfants s'approcher de la base de levage lorsqu'ils actionnent le mécanisme.
- Ne vous tenez PAS à l'intérieur du lit ou de la base de stockage interne.
- Ne surchargez pas la base de stockage interne.
- Ne pas sauter sur le produit ou l'une de ses parties.

## Italiano

### IMPORTANTE PER I LETTI CON SOLLEVAMENTO A GAS E LA MANUTENZIONE

- Posizionare il materasso sopra la struttura del letto.
- Non tirare le maniglie della cinghia.
- Premere con forza per rilasciare il gas compresso.
- Controllare periodicamente tutte le viti e i fissaggi per assicurarsi che siano saldi.
- Quando si sposta il prodotto, sollevarlo con cautela.
- Pulire con un panno leggermente umido, senza usare prodotti chimici abrasivi o candeggina.
- NON permettere ai bambini di azionare il meccanismo di sollevamento.
- NON permettere ai bambini di avvicinarsi alla base di sollevamento quando si aziona il meccanismo.
- NON sostare all'interno del letto o della base di contenimento interna.
- NON sovraccaricare la base di contenimento interna.
- NON saltare sul prodotto o sulle sue parti.

## Español

### IMPORTANTE PARA LAS CAMAS ELEVADORAS DE GAS&MANTENIMIENTO

- Coloque el colchón sobre el somier.
- No tire de las asas de la correa.
- Presione con fuerza para liberar el gas comprimido.
- Compruebe periódicamente que todos los tornillos y fijaciones estén bien sujetos.
- Al mover el producto, levántelo con cuidado para colocarlo en su sitio.
- Limpie con un paño ligeramente humedecido; no utilice productos químicos abrasivos ni lejía.
- NO permita que los niños accionen el mecanismo de elevación.
- NO permita que los niños se acerquen a la base elevadora cuando accionen el mecanismo.
- NO se ponga de pie dentro de la cama o de la base de almacenamiento interna.
- NO sobrecargue el somier.
- NO salte sobre el producto ni sobre ninguna de sus piezas.



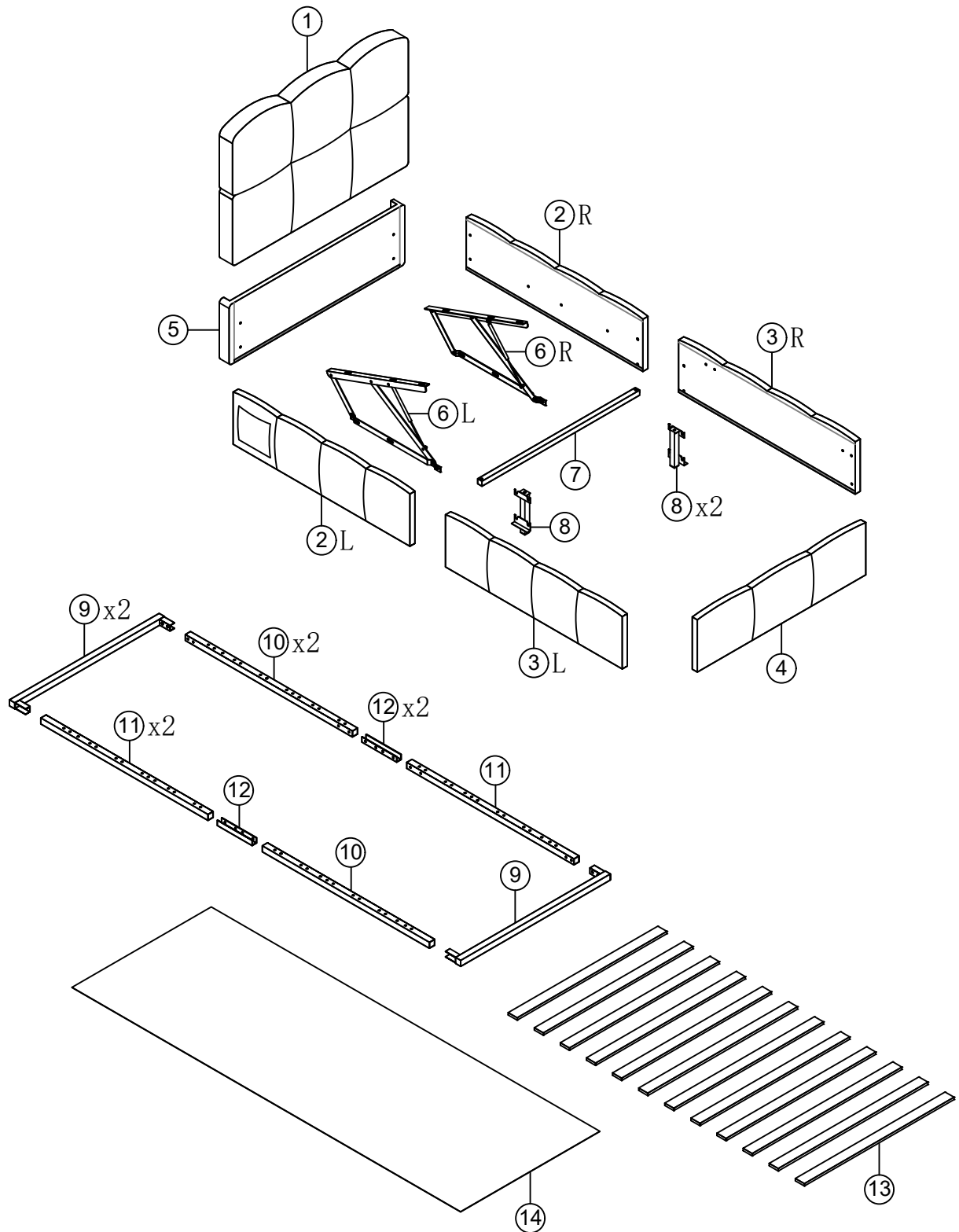

# Detail View

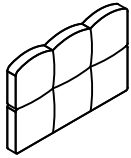
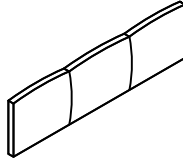
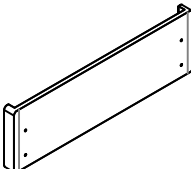

# Part List

## N606P434436

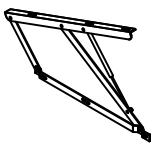
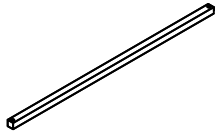
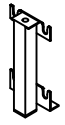
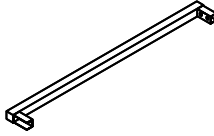
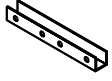
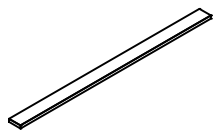
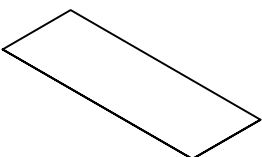



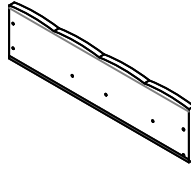
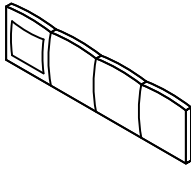
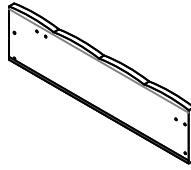
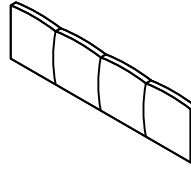
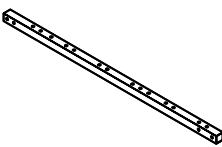
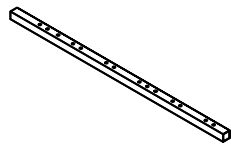



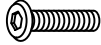

<p>1</p>  <p>Head board-1PC</p>	<p>4</p>  <p>Foot board-1PC</p>	<p>5</p>  <p>Base head board-1PC</p>
<p>6R</p>  <p>Gas lift -1PC</p>	<p>6L</p>  <p>Gas lift -1PC</p>	<p>7</p>  <p>Metal cross bar-1PC</p>
<p>8</p>  <p>Side rails support legs-2PCS</p>	<p>9</p>  <p>Metal frame cross bar-2PCS</p>	<p>12</p>  <p>Connection fitting-2PCS</p>
<p>13</p>  <p>Slats-12PCS</p>	<p>14</p>  <p>Black non woven fabric-1PC</p>	

## N606P434437

<p>2R</p>  <p>Side rail-1PC</p>	<p>2L</p>  <p>Side rail-1PC</p>	<p>3R</p>  <p>Side rail-1PC</p>
<p>3L</p>  <p>Side rail-1PC</p>	<p>10</p>  <p>Metal frame side bar-2PCS</p>	<p>11</p>  <p>Metal frame side bar-2PCS</p>

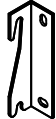
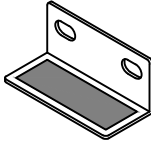
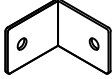
# Hardware List

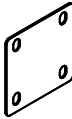
## N606P434436

<p>Ax1</p>  <p>Allen Key</p>	<p>Bx66</p>  <p>M8x18mm</p> <p>Bolts</p>	<p>Cx6</p>  <p>M8x45mm</p> <p>Bolts</p>
<p>Dx4</p>  <p>Nuts</p>	<p>Ex4</p>  <p>Nuts</p>	<p>Fx1</p>  <p>Spanner</p>
<p>Gx2</p>  <p>Hinge</p>	<p>Hx2</p>  <p>"7" Connector</p>	<p>Ix2</p>  <p>Little "7" Connector</p>
<p>Jx2</p>  <p>Metal Corner</p>	<p>Kx2</p>  <p>Four hole iron</p>	<p>Lx1</p>  <p>Four hole iron</p>
<p>Mx1</p>  <p>Pull tape</p>	<p>Nx24</p>  <p>End slats cap</p>	

**DE:** Vor dem Einbau die Schrauben in die Löcher stecken und festziehen, aber nicht bis 100%, 70% bis 80% anziehen reicht aus. Schließlich, nachdem alle Schrauben installiert sind, ziehen Sie alle Schrauben auf 100%.

Wenn Sie auf diese Probleme stoßen, wie z. B. Fehlausrichtung der Löcher oder Unfähigkeit, bestimmte Teile zu installieren, überprüfen Sie bitte, ob die Schrauben korrekt verwendet werden und passen Sie die Dichtigkeit der Schrauben an.

**UK:** Before installation, insert the screws into the holes and tighten them, but do not tighten them to 100%, 70% to 80% is sufficient. Finally, after all screws are installed, tighten all screws to 100%.

If you encounter these issues, such as if the holes cannot be aligned or some parts cannot be installed, please check if the screws are used correctly and adjust the tightness of the screws.

**FR:** Insérer la vis dans le trou avant la fin de l'assemblage, serrer la vis, mais ne pas serrer à 100%, 70% ~ 80% est correct. Enfin, une fois que toutes les vis sont bien serrées, toutes les vis sont serrées à 100%.



Si vous rencontrez ces problèmes, par exemple si les trous ne sont pas alignés ou si certaines pièces ne peuvent pas être montées, vérifiez que les vis sont utilisées correctement et Ajustez leur serrage.

Attention: Do not tighten the screws before completing the entire installation. If you have any difficulty with the installation process, please feel free to contact us.

### Step 1:

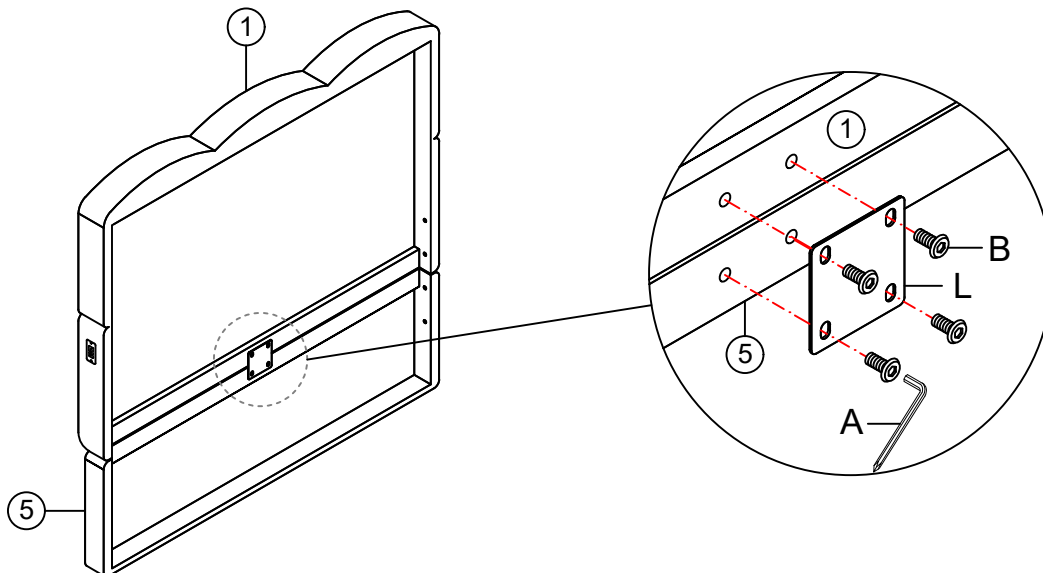
Fix the Top head board ① to the Base head board ⑤ with Bolts B and Four hole iron L by using Allen key A.





<p>A Allen Key</p> 	<p>B Bolts x 4 M8x18mm</p> 	<p>L Four hole iron x 1</p> 
---	--	---

### Step 2:

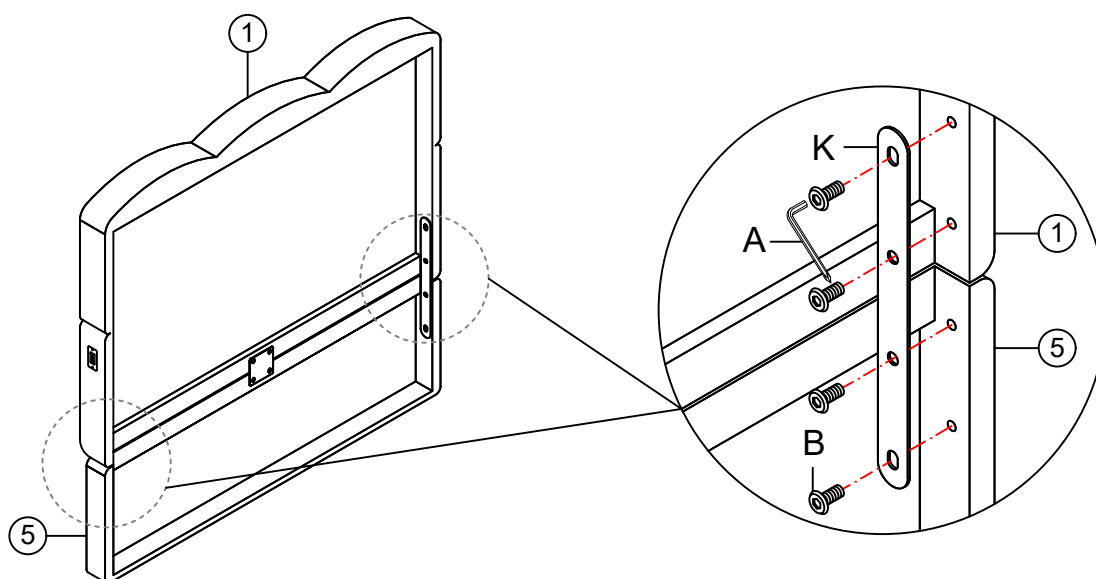
Fix the Top head board ① to the Base head board ⑤ with Bolts B and Four hole iron K by using Allen key A.



<p>A Allen Key</p> 	<p>B Bolts x 8 M8x18mm</p> 	<p>K Four hole iron x 2</p> 
---	--	---

### Step 3:

Fix the Side rails Support legs (8) to the Side rail (2) and (3) with Bolts B by using Allen key A.

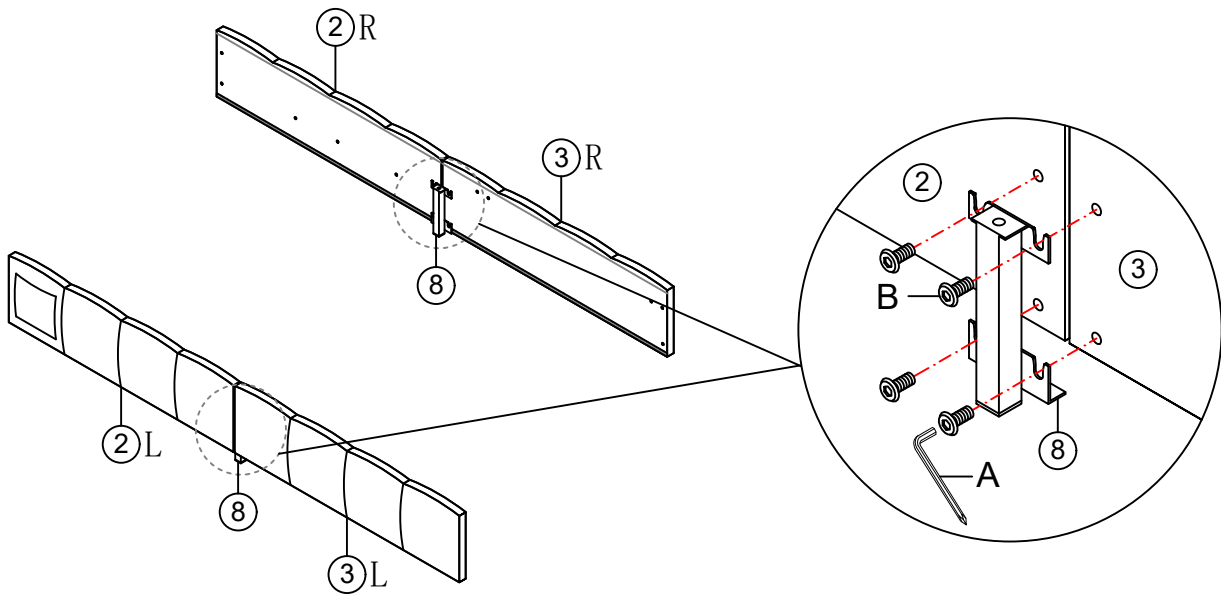

A Allen Key



B Bolts x 8



M8x18mm

### Step 4:

Fix the Side rail (2) to the Base head board (5) with Bolts B and Hinge G by using Allen key A.

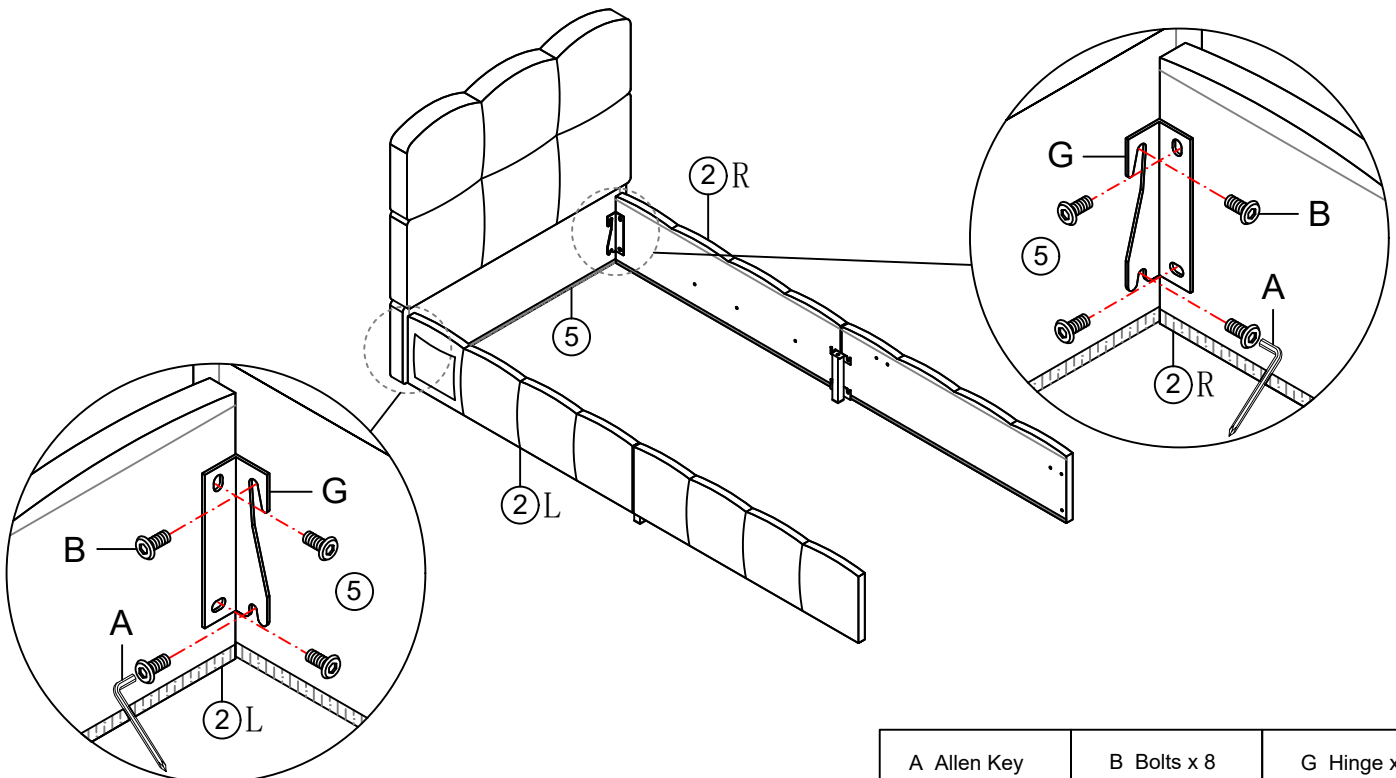

A Allen Key



B Bolts x 8



M8x18mm





G Hinge x 2

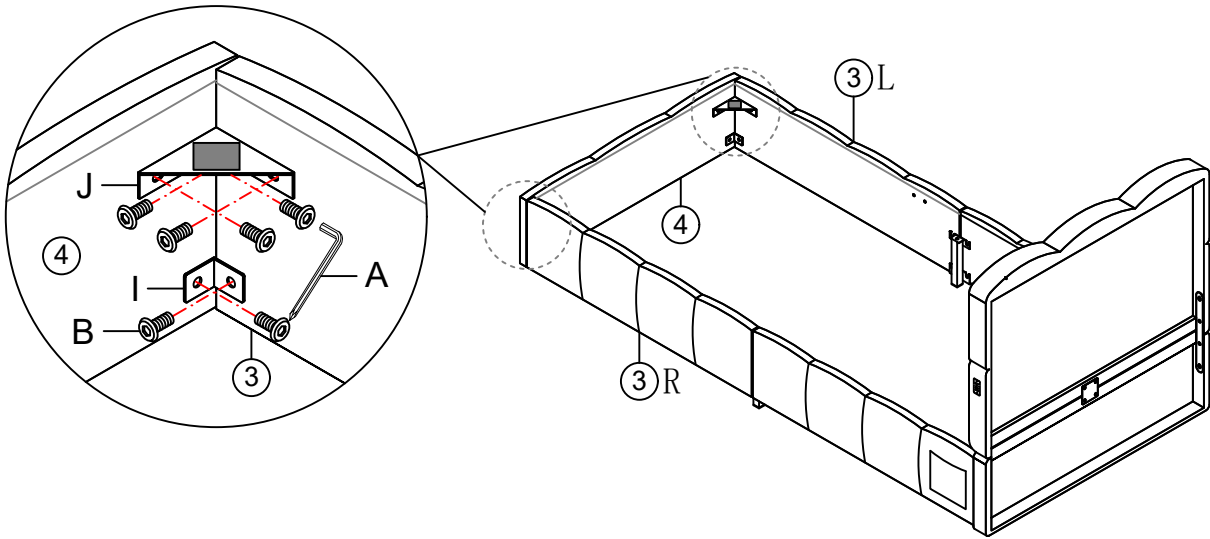

## Step 5:

Fix the Foot board (4) to the Side rail (3) with Bolts B, Little "7" Connector I and Metal Corner J by using Allen key A.





A Allen Key 	B Bolts x 12 M8x18mm 	I Little "7" Connector x 2 	J Metal Corner x 2 
--	---	---	---

## Step 6:

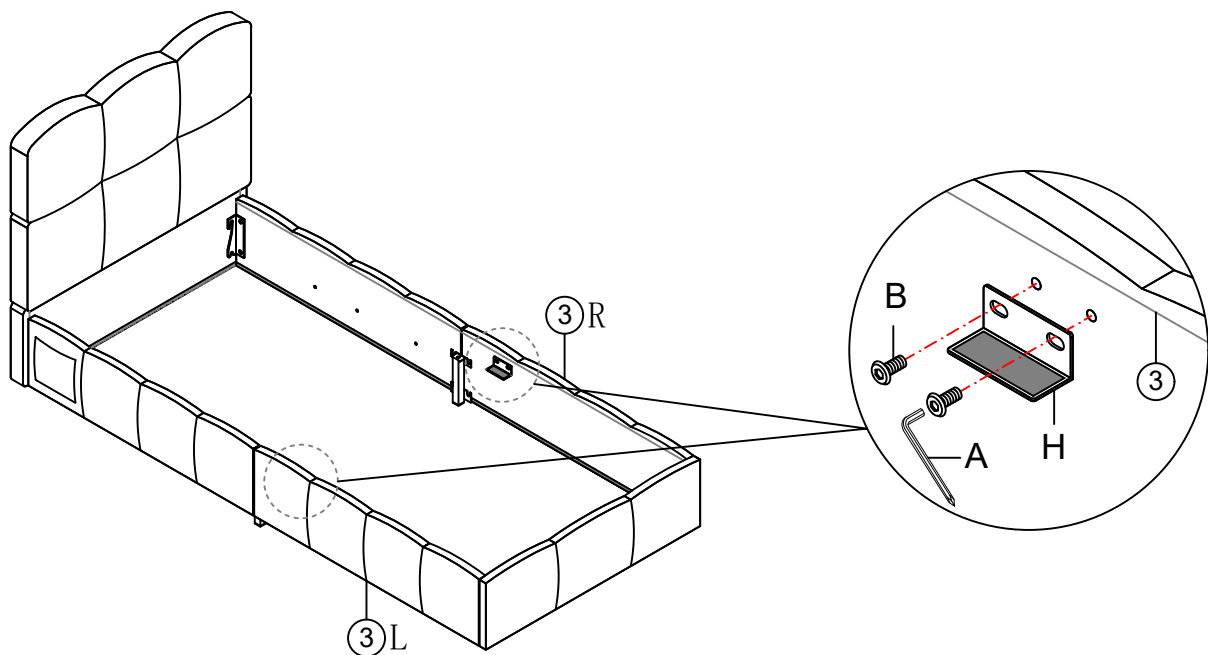
Fix the "7" Connector H to the Side rail (3) with Bolts B by using Allen key A.



A Allen Key 	B Bolts x 4 M8x18mm 	H "7" Connector x 2 
---	---	--

## Step 7:

Fix the Gas lift (6) to the Side rail (2) with Bolts B and Nuts E by using Allen key A and Spanner F.

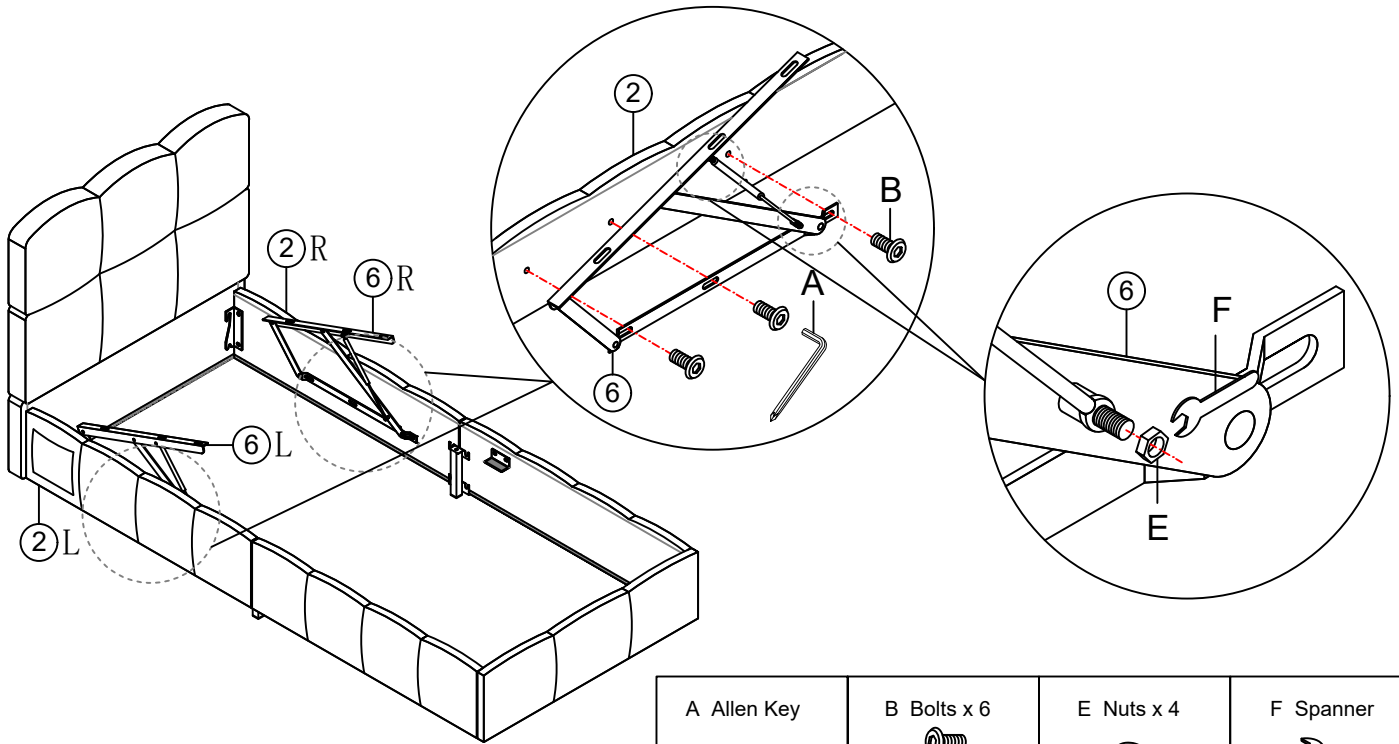

## Step 8:

Stick the Black non woven fabric (14) to the side rail (2), side rail (3), Foot board (4) and Base head board (5).

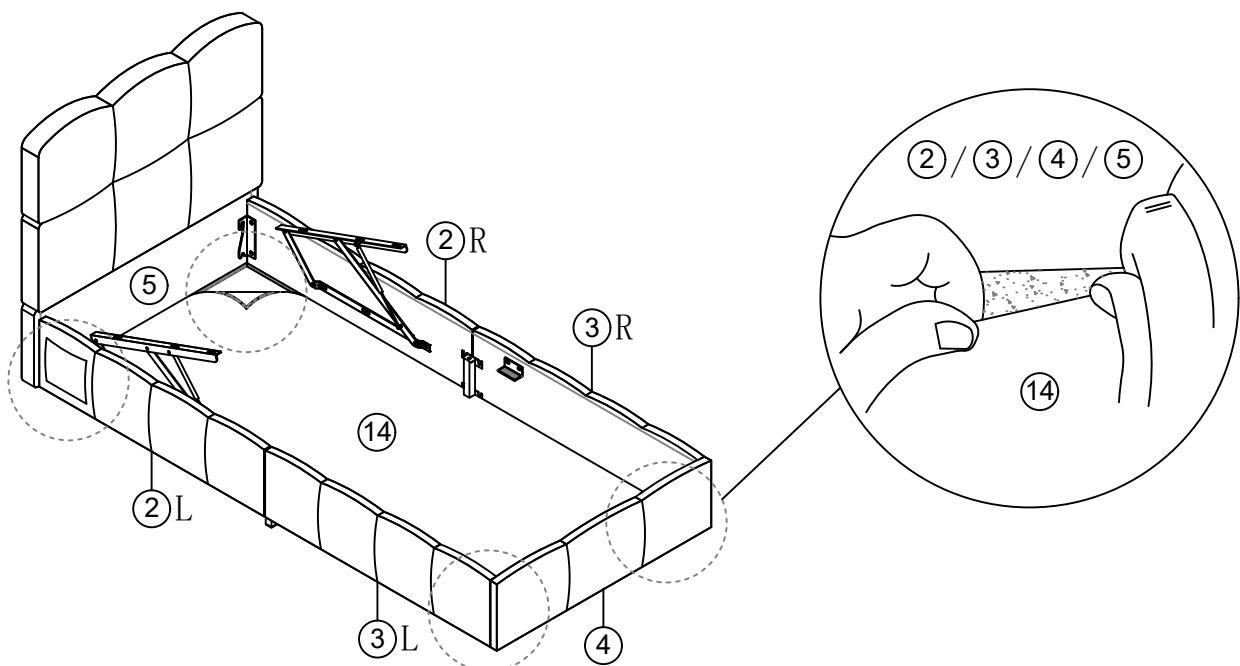

## Step 9:

Fix the Metal cross bar (7) to the Side rails support legs (8) with Bolts C by using Allen key A.

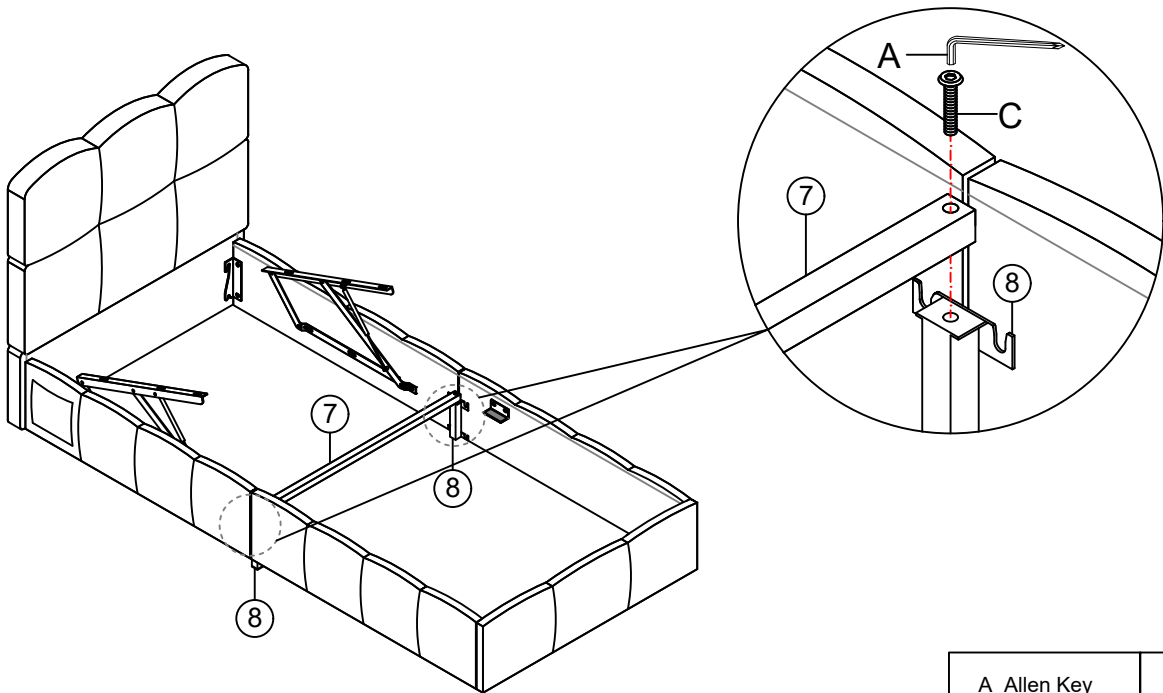

A Allen Key



C Bolts x 2



M8x45mm

## Step 10:

Fix the Metal frame side bar (10) and (11) together with the Connection fitting (12) and Bolts B by using Allen Key A.

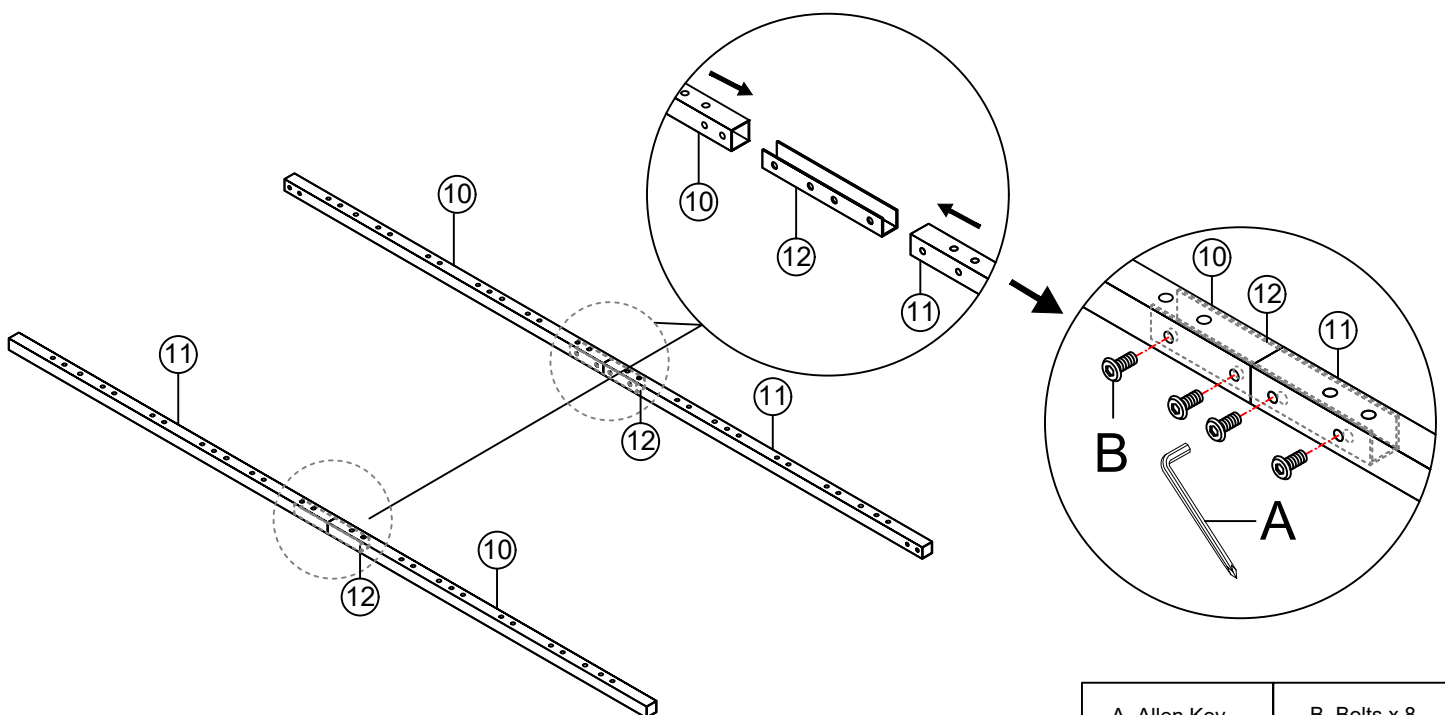

A Allen Key



B Bolts x 8



M8x18mm

## Step 11:

Fix the Metal frame cross bar ⑨ to the Metal frame side bar ⑩ and ⑪ with Bolts B by using Allen key A .

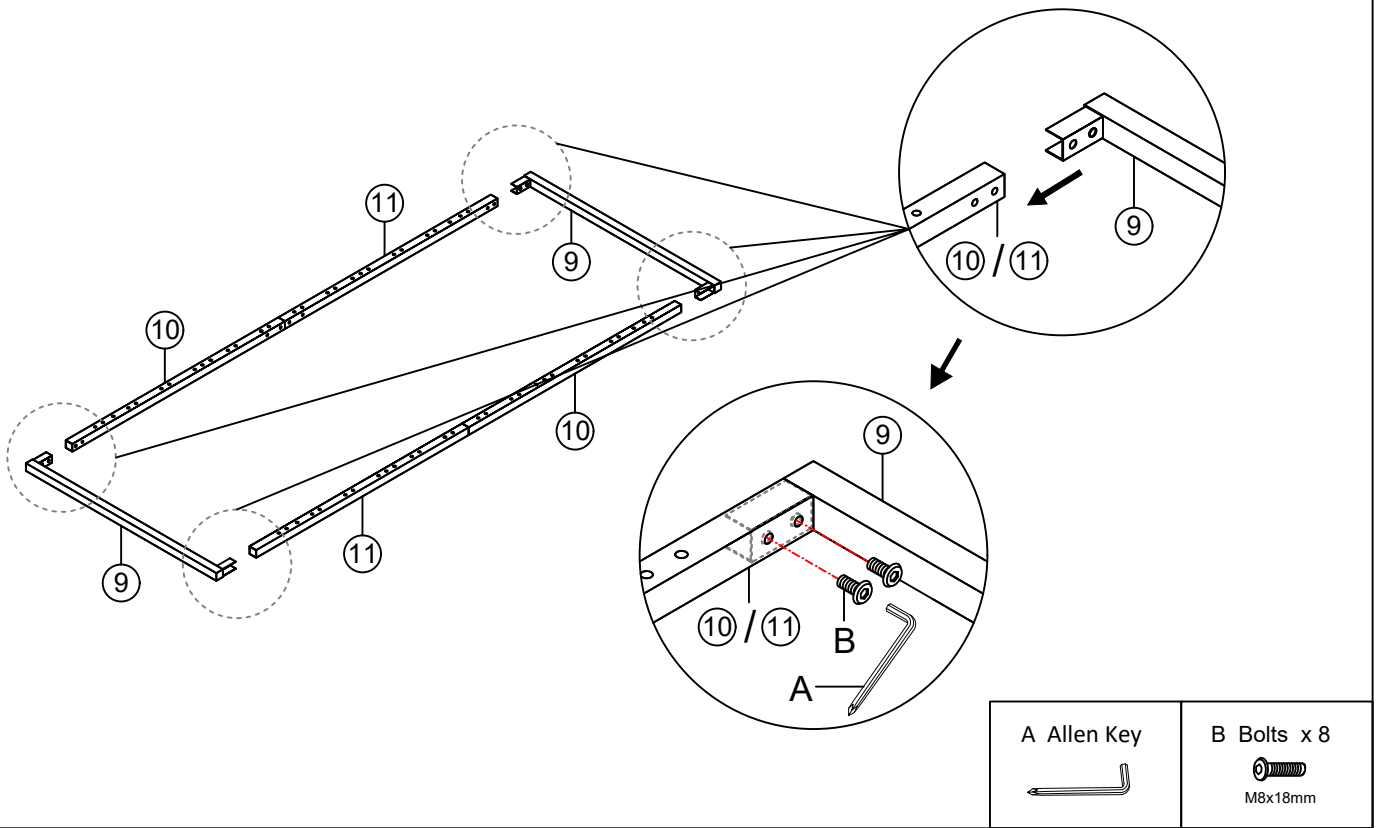

## Step 12:

Assemble the slats into the assembled slats frame with End slats cap N.

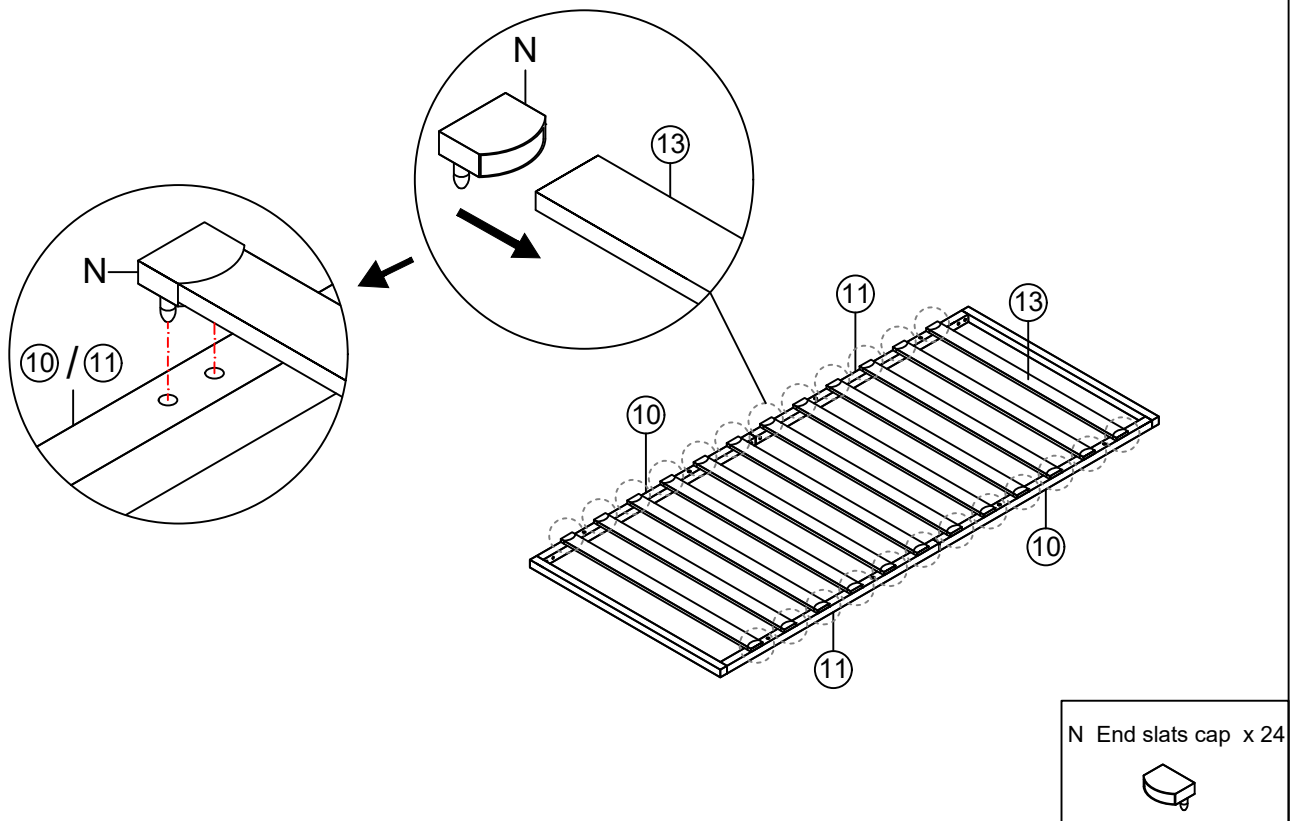

### Step13:

Fix the assembled slats frame to the Gas lift ⑥ with Bolts C and Nuts D by using Allen key A and Spanner F.

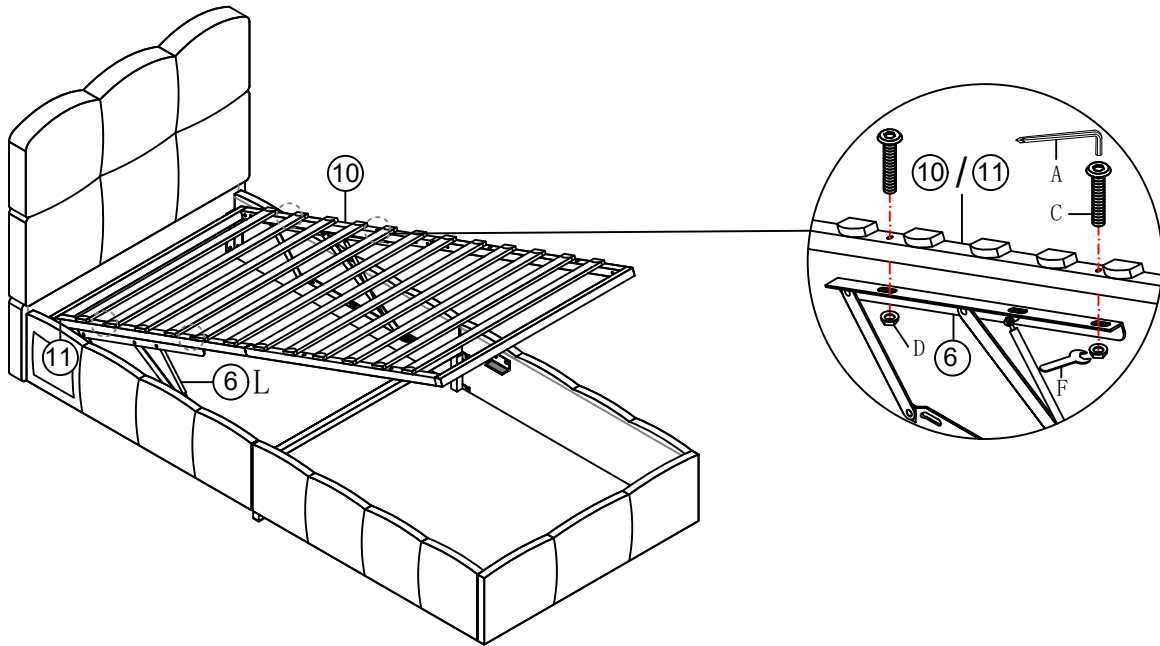

A Allen Key



C Bolts x 4  
M8x45mm



D Nuts x 4



F Spanner



### Step14:

Put the pull tape M in side middle of the slat frame.

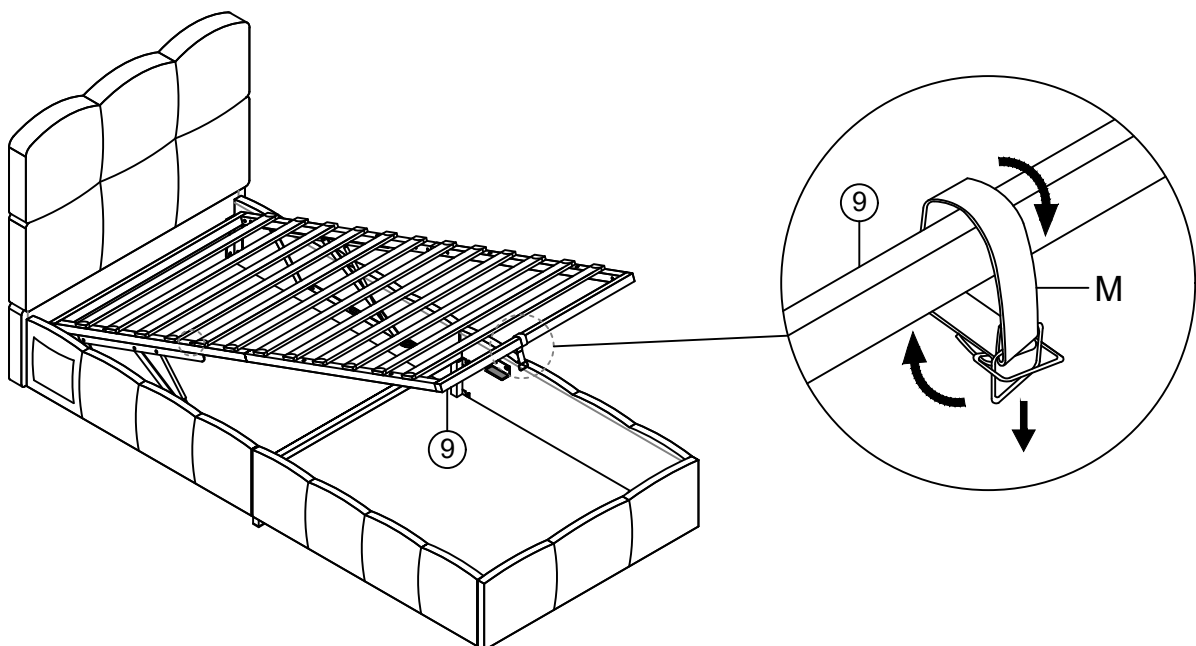

M Pull tape x 1



## Step15:

Please connect to power.

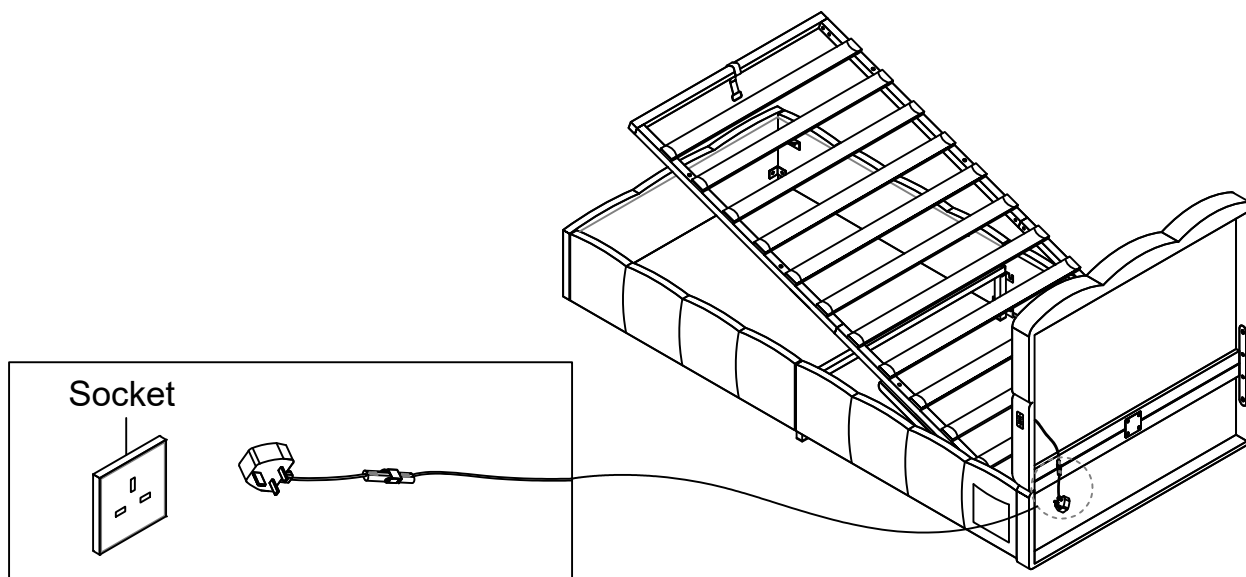

## Step16:

Every thing is finished now, please enjoy your bed.

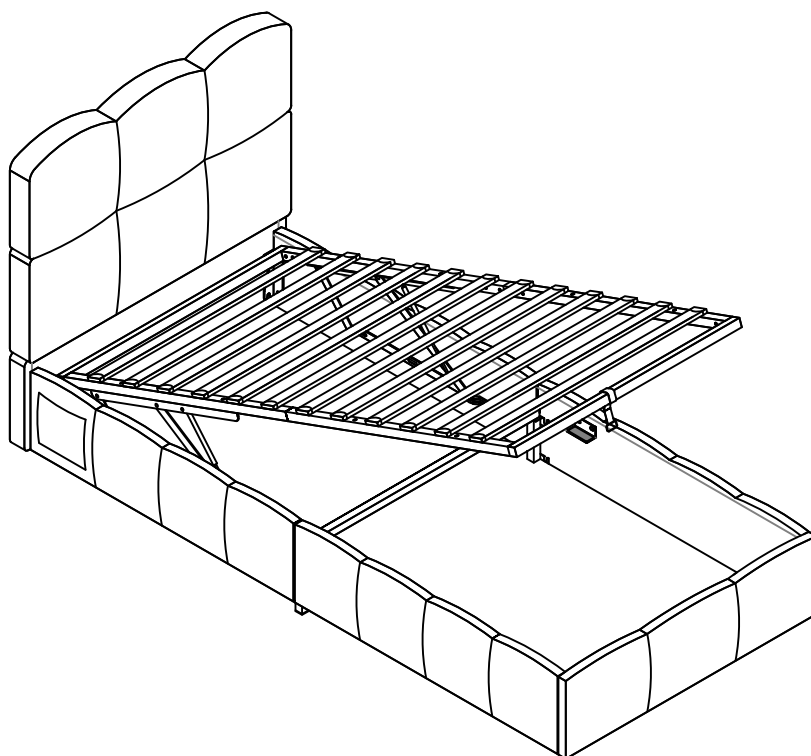

Question: What to do if the slat frame is tilted?

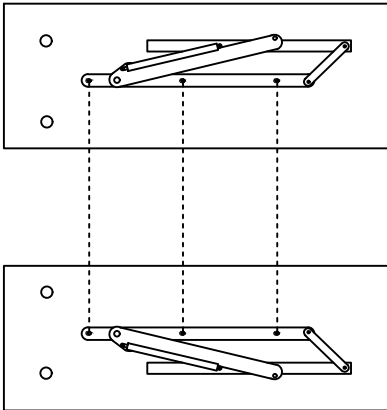

Answer:

The hole on the hydraulic rod is oval. Please make sure that the installation positions on the left and right sides are the same. If you accidentally install one side of the hydraulic rod in the front and the other side in the back, the slat frame will be crooked and you will need to disassemble it and reinstall it.

Das Loch an der Hydraulikstange ist oval. Bitte stellen Sie sicher, dass die Einbaupositionen auf der linken und rechten Seite gleich sind. Wenn Sie versehentlich eine Seite der Hydraulikstange vorne und die andere Seite hinten einbauen, kann dies zu Problemen führen. Der Rahmen der Hydraulikstange ist schief und Sie müssen sie zerlegen und neu installieren.

Question: What to do if the hydraulic system fails to press down?

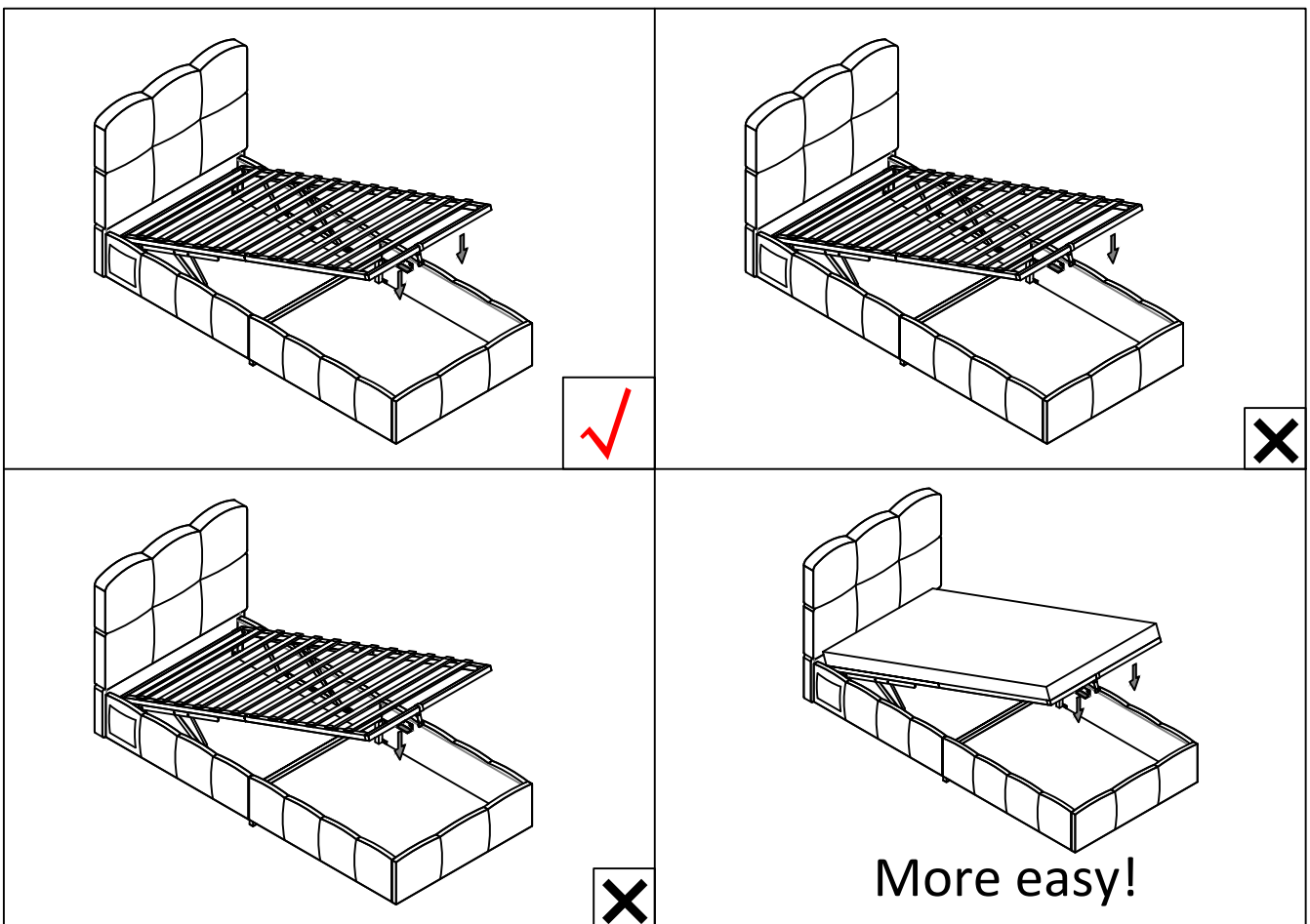

Answer:

When turning off the hydraulic pressure, make sure that the pressure point is at the position indicated by the arrow. Place your hand at the pressure point.

If you place the mattress on a slatted frame, it will be easier to turn off the hydraulic pressure. Please try it.

Do not press only on the left side or only on the right side, as this will damage the hydraulic system.

Stellen Sie beim Abschalten des Hydraulikdrucks sicher, dass sich der Druckpunkt dort befindet, wo der Pfeil anzeigt. Legen Sie Ihre Hände auf die Druckpunkte.

Wenn Sie die Matratze auf einen Lattenrost legen, lässt sich der hydraulische Druck leichter abstellen. Bitte probieren Sie es aus.

Drücken Sie nicht nur auf die linke oder nur die rechte Seite, da dies zu Schäden am Hydrauliksystem führen kann.