



MANUEL D'INSTRUCTIONS

INSTRUCTION MANUAL

Arvada 9,5 X 10,3 pi. Remise En Métal - Gris Foncé
Arvada 9.5 x 10.3 ft. Metal shed - Dark Grey

		SKU: SSR-DM01-091007-S35
--	--	--------------------------

**DO NOT DESTROY THE BOXES UNTIL COMPLETELY ASSEMBLED
FOR FUTURE REFERENCE,
TAKE PICTURES OF ALL SIX SIDES OF EACH OF THE BOXES UPON RECEIPT.
PLEASE VERIFY THE CONTENT OF EACH BOX AGAINST THE LIST OF PARTS**

**Instruction Manual
IMPORTANT: RETAIN FOR FUTURE REFERENCE, READ CAREFULLY**

Consult with your local governing authority / local municipal codes regarding installation of temporary structures before purchase or assembly. Some jurisdictions may require permits for, or otherwise regulate, installation and use.

For assistance with assembly, installation, parts, or customer service, contact Gazebo Penguin Customer Service Department at the numbers listed below (English & French, Mon-Fri 8:00 AM to 4:00 PM EST):

Montreal: (514) 276-3485

Elsewhere in Canada and the US: 1-800-737-7174

WARNING:

- For outdoor use.
- Snow should be regularly cleared from the roof and not allowed to accumulate.
- Retain your proof of purchase for warranty purposes.
- Also keep the original boxes until the installation is complete and correct.
- The unit may take 8–10 hours and a minimum of 2 adults are required for this assembly.
- This shed is designed for residential outdoor storage use only.
- Not intended for habitation.

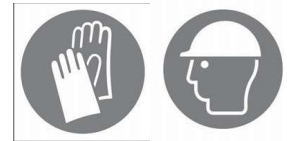

PRIOR TO ASSEMBLY:

- Consult local building codes and HOA requirements before installation.
- Select a level, well-drained area and avoid low areas where water collects.
- Keep clear of overhead utility lines, tree branches, roof lines, and structures that could shed snow, ice, or water onto the roof.
- Check for underground utilities before digging or anchoring.
- A solid, level foundation with good drainage is required. Foundation must extend at least 4 in (10 cm) beyond shed base on all sides.
- Do NOT install on loose gravel or unstable surfaces.
- Recommended: Concrete slab minimum 4 in (10 cm) thick with a polyethylene vapor barrier (minimum 6 mil / 150µm) beneath slab to reduce condensation.
- Assemble on a dry, calm day and finish assembly the same day to avoid product damage.
- Minimum 2 adults required. Allow 8–10 hours for assembly.
- Before assembly, verify all parts against parts list. Do not begin if parts are missing. Keep packaging until assembly is complete.
- Wear gloves and eye protection. Beware of sharp metal edges.
- Do not stand or sit on the roof. Keep children and pets away during assembly.

ANCHORING INSTRUCTIONS:

- Shed must be securely anchored to the foundation.
- Use appropriate anchors for your foundation type.
- Failure to properly anchor may result in wind damage.
- Inspect anchors annually.

CARE AND MAINTENANCE:

- Ensure proper ventilation.
- Apply exterior-grade silicone along interior base rail after anchoring.
- Store items off floor when possible.
- Remove snow accumulation promptly.
- Touch up scratches to prevent rust.
- Lubricate door tracks periodically.
- Clean with mild soap and water.
- Do not use abrasive cleaners or pressure washers.

**NE DÉTRUISEZ PAS LES BOÎTES AVANT QUE L'ABRI SOIT COMPLÈTEMENT ASSEMBLÉ
POUR LA RÉFÉRENCE FUTURE, PRENEZ DES PHOTOS DE TOUS LES SIX CÔTÉS DE CHACUNES
DES BOÎTES À LA RÉCEPTION DU PRODUIT.
VEUILLEZ VÉRIFIER LE CONTENU DE CHAQUE BOÎTE A L'AIDE DE LA LISTE DES PIÈCES**

**LES INSTRUCTIONS D'INSTALLATION
IMPORTANTE: RETENIR POUR LA FUTURE RÉFÉRENCE, LIRE ATTENTIVEMENT**

Consultez votre autorité locale / les codes municipaux locaux concernant l'installation de structures temporaires avant l'achat ou l'assemblage. Certaines juridictions peuvent exiger des permis pour, ou réglementer autrement, l'installation et l'utilisation.

Pour l'assistance de l'assemblage, d'installation, des pièces en particulier, ou service à la clientèle, veuillez contacter Gazebo Penguin au numéro de téléphone mentionné mi-bas : (français, anglais, lun. à ven. de 8 du matin à 4 après-midi est) :

Montréal: (514) 276-3485

Canada et États-Unis: 1-800-737-7174

AVERTISSEMENT:

- Pour usage extérieur uniquement.
- La neige doit être retirée régulièrement du toit et ne doit pas s'accumuler.
- Conservez votre preuve d'achat aux fins de garantie.
- Conservez également les boîtes d'origine jusqu'à ce que l'installation soit complète et conforme.
- L'assemblage peut prendre de 8 à 10 heures et nécessite un minimum de 2 adultes.
- Cet abri est conçu uniquement pour le rangement extérieur à usage résidentiel.
- Non destiné à l'habitation.

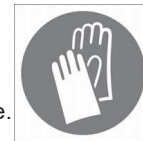

AVANT DE COMMENCER:

- Consultez les codes du bâtiment locaux ainsi que les exigences de votre association de propriétaires (HOA) avant l'installation.
- Choisissez un emplacement plat et bien drainé et évitez les zones basses où l'eau peut s'accumuler.
- Maintenez une distance sécuritaire des lignes électriques aériennes, des branches d'arbres, des lignes de toit et des structures pouvant laisser tomber de la neige, de la glace ou de l'eau sur le toit.
- Vérifiez la présence de conduites ou de câbles souterrains avant de creuser ou d'installer les ancrages.
- Une fondation solide, de niveau et bien drainée est requise. La fondation doit dépasser d'au moins 4 po (10 cm) la base de l'abri sur tous les côtés.
- Ne PAS installer sur du gravier meuble ou des surfaces instables.
- Recommandé : dalle de béton d'une épaisseur minimale de 4 po (10 cm) avec barrière pare-vapeur en polyéthylène (minimum 6 mil / 150 µm) sous la dalle afin de réduire la condensation.
- Assemblez par temps sec et calme et complétez l'assemblage la même journée afin d'éviter tout dommage au produit.
- Minimum 2 adultes requis. Prévoir de 8 à 10 heures pour l'assemblage.
- Avant l'assemblage, vérifiez toutes les pièces à l'aide de la liste des pièces. Ne commencez pas si des pièces sont manquantes. Conservez l'emballage jusqu'à ce que l'assemblage soit terminé.
- Portez des gants et des lunettes de protection. Attention aux arêtes métalliques coupantes.
- Ne pas se tenir debout ni s'asseoir sur le toit. Gardez les enfants et les animaux domestiques éloignés pendant l'assemblage.

EXIGENCES D'ANCRAGE:

- L'abri doit être solidement ancré à la fondation.
- Utilisez des ancrages appropriés au type de fondation.
- Un ancrage inadéquat peut entraîner des dommages causés par le vent.
- Inspectez les ancrages annuellement.

ENTRETIEN:

- Assurez une ventilation adéquate.
- Appliquez un scellant au silicone de qualité extérieure le long du rail de base intérieur après l'ancrage.
- Rangez les articles surélevés du sol lorsque possible.
- Retirez rapidement toute accumulation de neige.
- Retouchez les égratignures afin de prévenir la rouille.
- Lubrifiez périodiquement les rails de la porte.
- Nettoyez avec un savon doux et de l'eau.
- N'utilisez pas de nettoyeurs abrasifs ni de nettoyeur à pression.

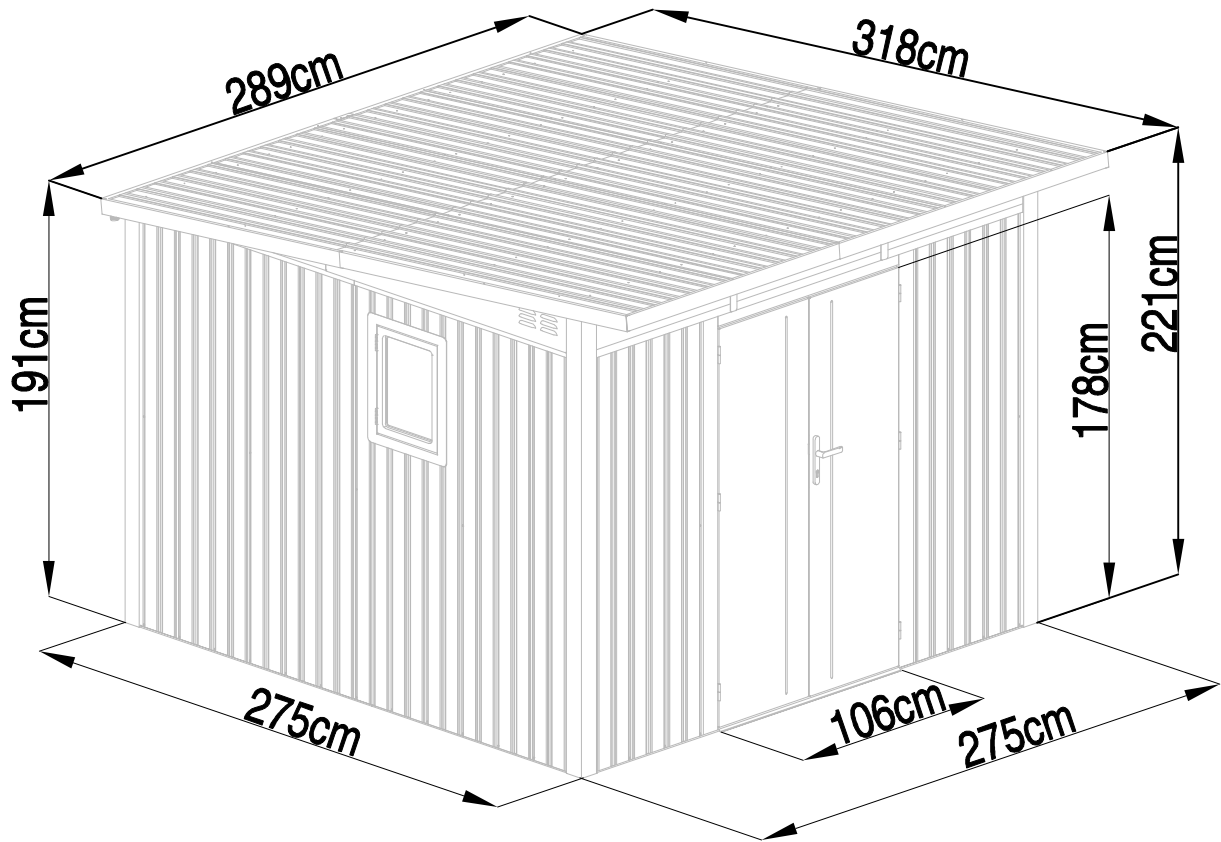

Dimensions de la zone où le produit sera installé
Dimensions of the area where the product will be installed

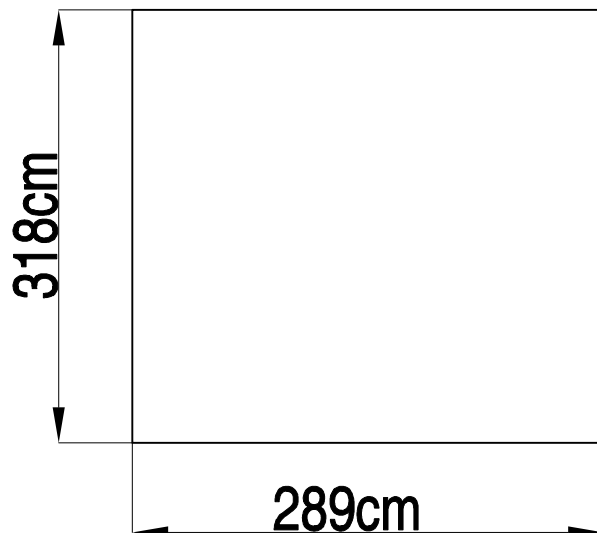

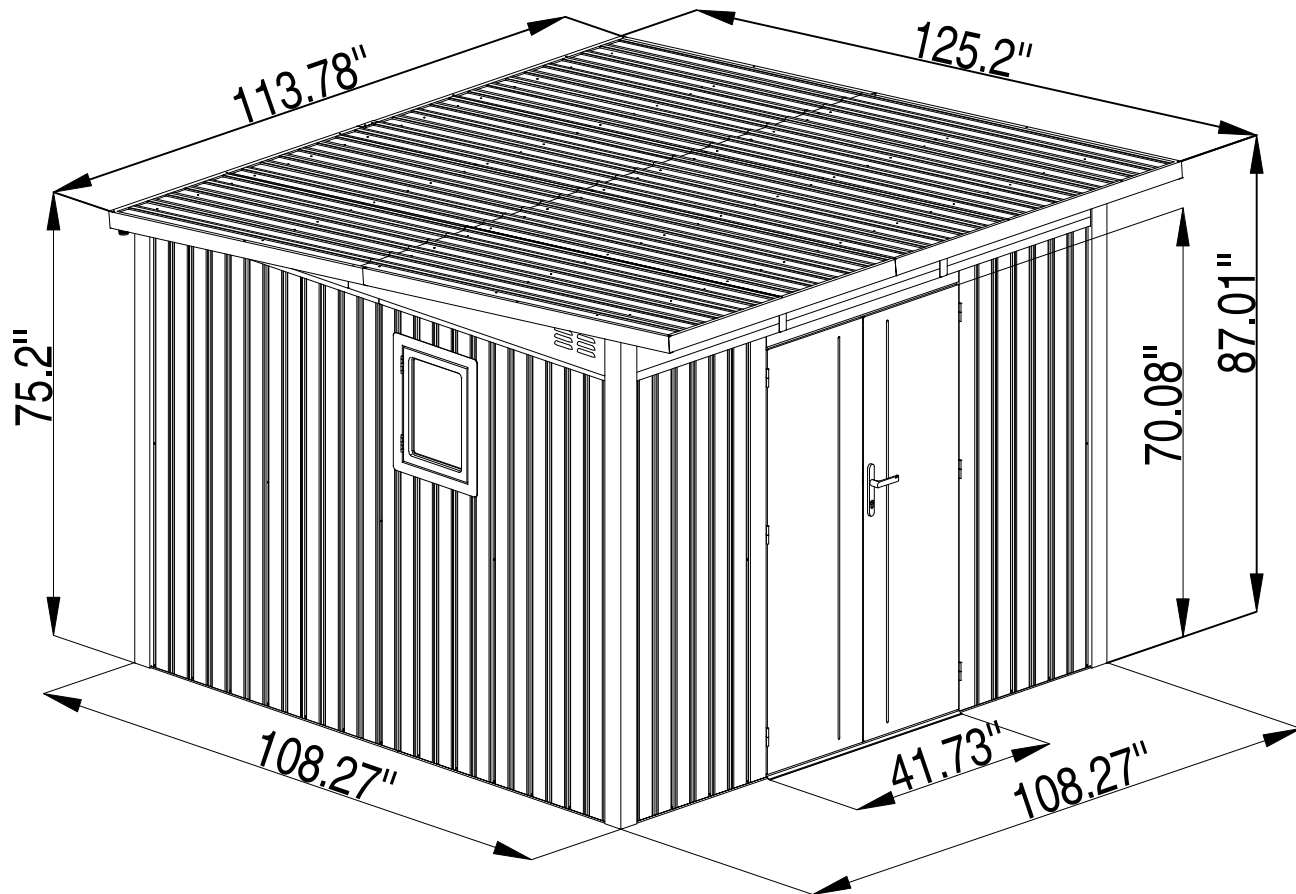



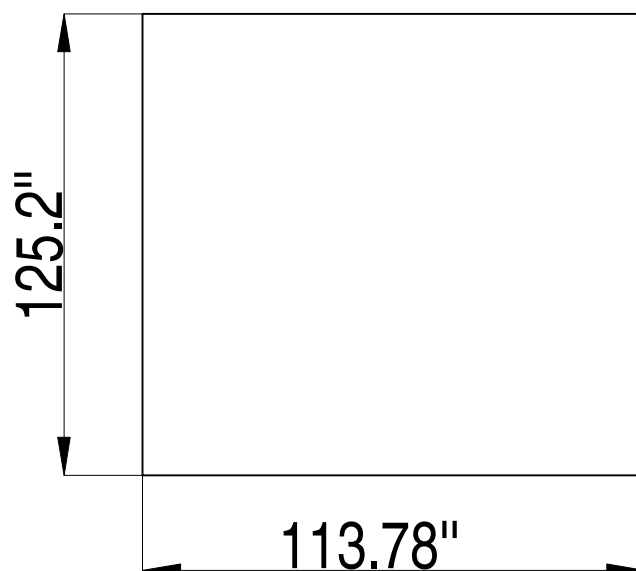





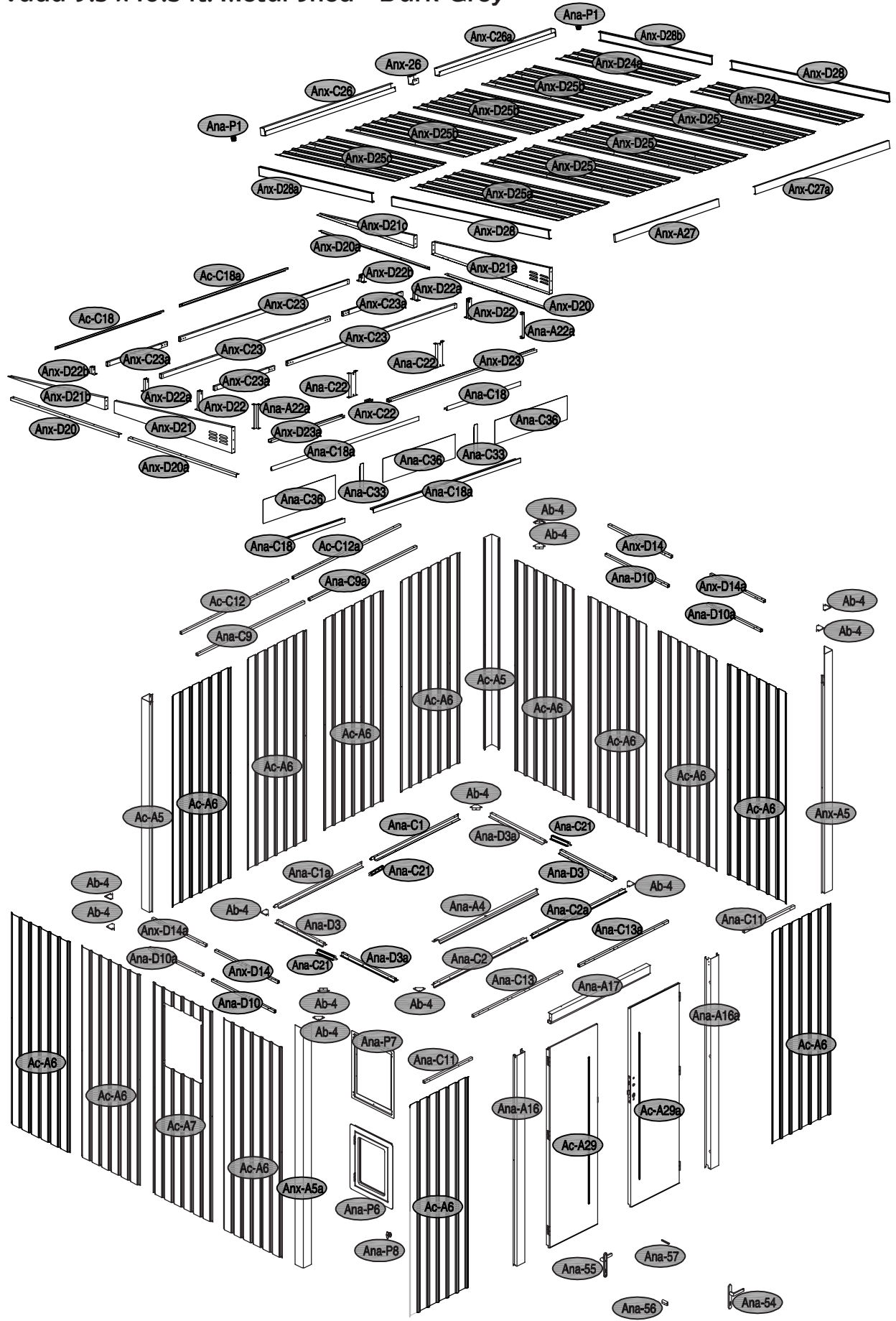





























Dimensions de la zone où le produit sera installé
Dimensions of the area where the product will be installed









Arvada 9,5 X 10,3 pi. Remise En Métal - Gris Foncé







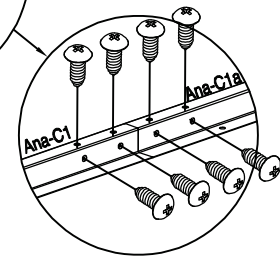
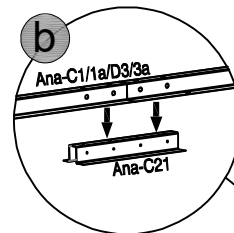
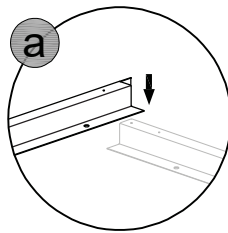
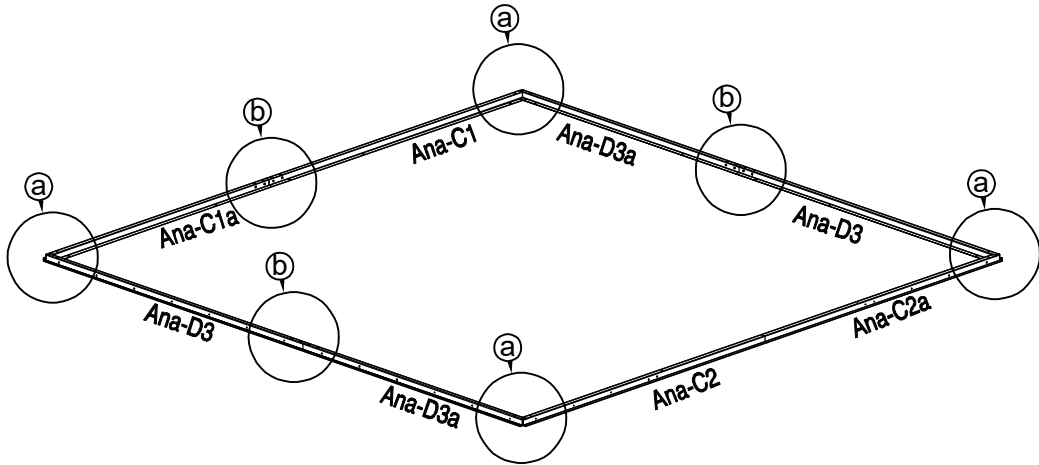

Arvada 9.5 x 10.3 ft. Metal Shed - Dark Grey



NO.	GP NO.	IMAGE	mm	QTY	NO.	GP NO.	IMAGE	mm	QTY	
UNDER					Ana-C21	26-101		190	3	
Ana-C1	26-086		1458	1	Anx-D22	26-125		179	2	
Ana-C1a	26-087		1245	1	Anx-D22a	26-126		120	2	
Ana-C2	26-088		1371.5	1	Anx-D22b	26-127		62	2	
Ana-C2a	26-089		1331.5	1	Ana-C22	26-102		223	2	
Ana-D3	26-113		1458	2	Ana-A22a	26-029		223	2	
Ana-D3a	26-114		1245	2	Anx-C22	26-103		70	1	
Ana-A4	26-006			1130	1	Anx-C23	26-104		2079.5	3
MIDDLE					Anx-C23a	26-105	737		3	
Ac-A5	26-007		1900	2	Anx-D23	26-106		1812	1	
Anx-A5	26-008		2152	1	Anx-D23a	26-107		903	1	
Anx-A5a	26-009		2152	1	Ana-C36	26-108		890	3	
Ac-A6	26-010		1900	13	Ana-C33	26-109		272	2	
Ac-A7	26-011		1900	1	DOOR					
Ana-C9	26-090		1521.5	1	Ac-A29	26-033		1804	1	
Ana-C9a	26-091		1191.5	1	Ac-A29a	26-034		1804	1	
Ana-D10	26-115		1541	2	TOP					
Ana-D10a	26-116		1211	2	Anx-D24	26-128		1797	1	
Ana-C11	26-092		783.5	2	Anx-D24a	26-129		1447.5	1	
Ac-C12	26-093			1531.5	1	Anx-D25	26-130		1797	3
Ac-C12a	26-094			1181.5	1	Anx-D25a	26-131		1797	1
Ana-C13	26-095			1521.5	1	Anx-D25b	26-132		1447.5	3
Ana-C13a	26-096			1191.5	1	Anx-D25c	26-133		1447.5	1
Anx-D14	26-117			1541	2	Anx-D28	26-134			1734
Anx-D14a	26-118	1211		2	Anx-D28a	26-135	1456.5			1
Ana-A16	26-019			1900	1	Anx-D28b	26-136	1456.5		1
Ana-A16a	26-020			1900	1	Anx-A27	26-038	1296.9		1
Ana-A17	26-021			1087.5	1	Anx-C27a	26-110	1616.4	1	
Ana-C18	26-097			904.5	2	Anx-C26	26-111		1447	1
Ana-C18a	26-098			1811.5	2	Anx-C26a	26-112		1447	1
Ac-C18	26-099			1299.5	1	ANNEX				
Ac-C18a	26-100		1299.5	1	Ana-P1	26-044			2	
Anx-D20	26-119		1329	2	Anx-26	26-045		90	1	
Anx-D20a	26-120		1329	2	Ab-4.	26-046			12	
Anx-D21	26-121		1447	1	Anx-C37	26-047			5.3M	
Anx-D21a	26-122		1447	1	Ana-P6	26-048			1	
Anx-D21b	26-123		1190	1	Ana-P7	26-049			1	
Anx-D21c	26-124		1190	1	Ana-P8	26-050			1	
					Ab-50	26-051			6	

NO.	GP NO.	IMAGE	mm	QTY
Ana-54	26-052			1
Ana-55	26-053			1
Ana-56	26-054			1
Ana-57	26-055			1
Ana-58	26-056		M5X45	3
Anx-D40	26-057		M4	256
Anx-D41	26-058		ST4x10	437
Ana-A42	26-213		ST4X10	2
Anx-C42	26-062		M6x12	2
Anx-A43	26-059		M4x10	18
Anx-A44	26-060		M5x8	4
Anx-D45	26-061		ST4x25	19
Anx-D46	26-215		M4x10	21
Anx-D47	26-214		ST4x16	4
Anx-D48	26-063		M6x25	9



							
Ana-C1 x1	Ana-C1a x1	Ana-C2 x1	Ana-C2a x1	Ana-D3 x2	Ana-D3a x2	Ana-C21 x3	Anx-D41 x24

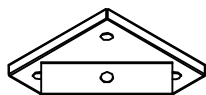
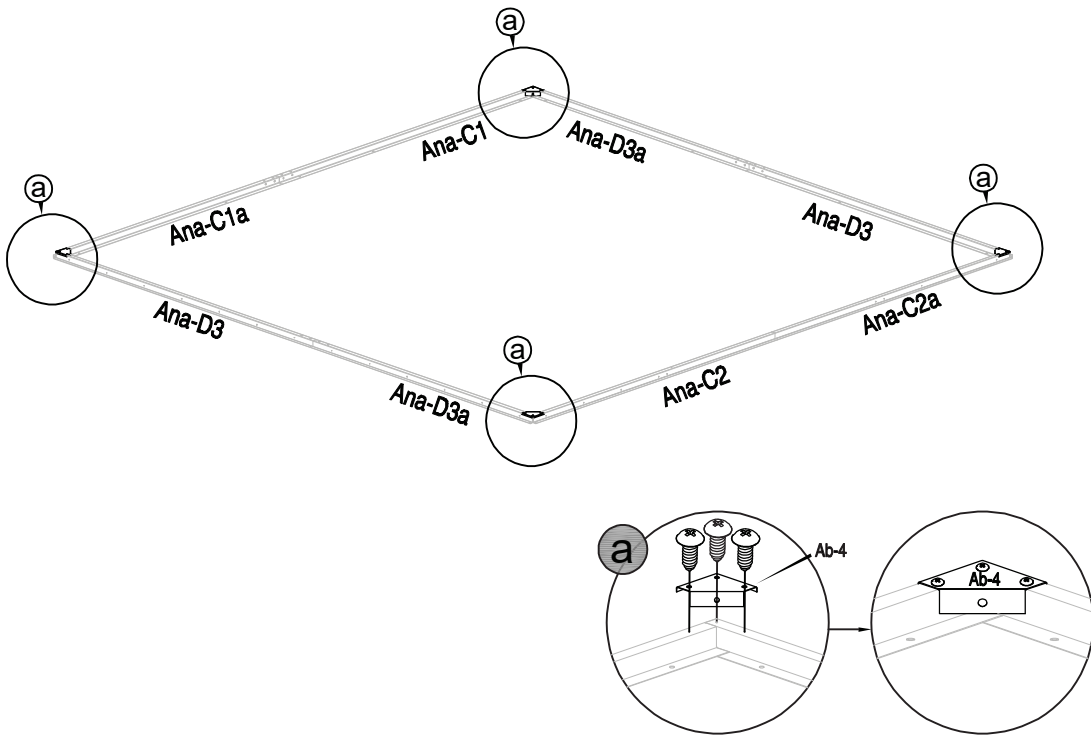





Ab-4 x4

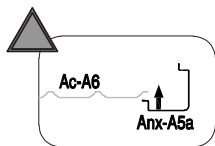
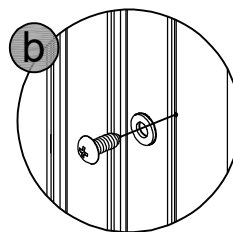
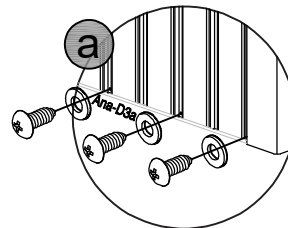
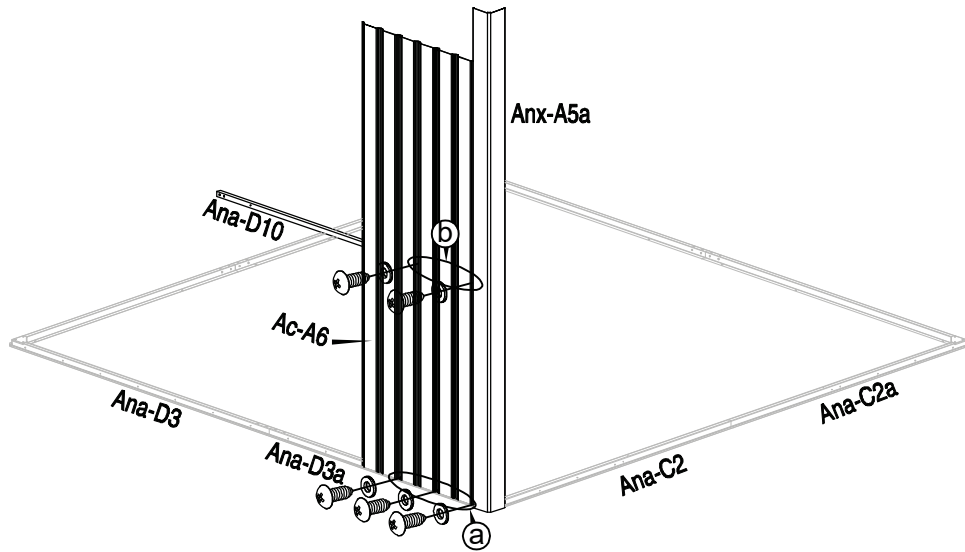

Anx-D41 x12



 <p>Ac-A6 x1</p>	 <p>Anx-A5a x1</p>	 <p>Ana-D10 x1</p>	 <p>Anx-D41 x5</p>	 <p>Anx-D40 x5</p>
---	---	---	---	---

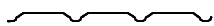
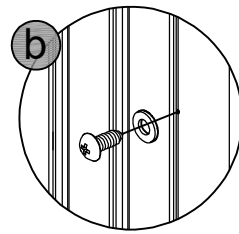
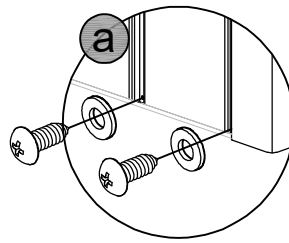
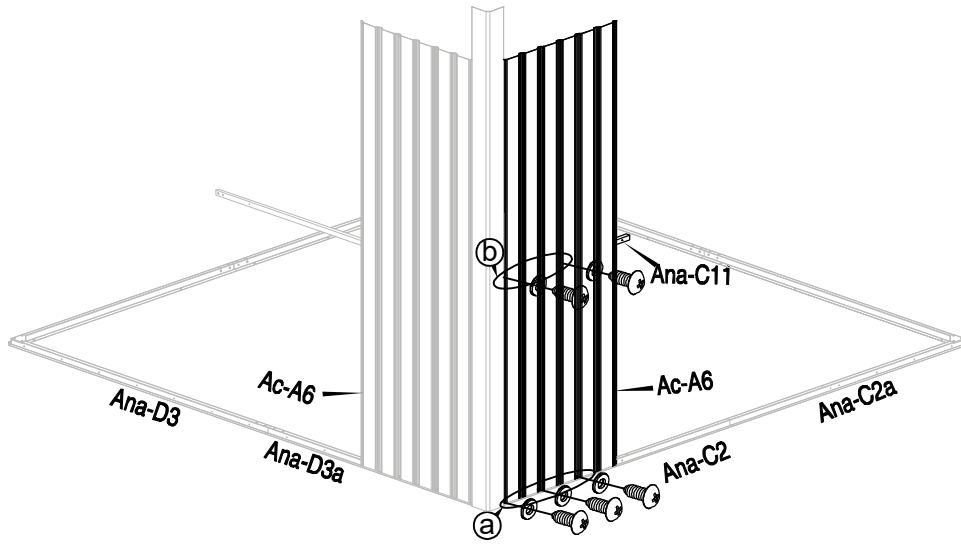

Ac-A6 x1



Ana-C11 x1

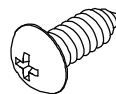

Anx-D41 x5



Anx-D40 x5

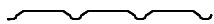
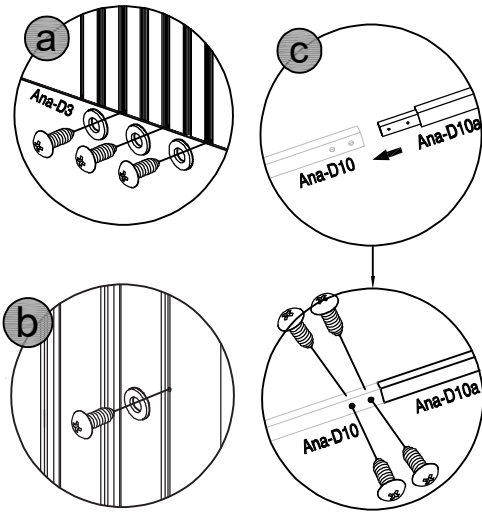
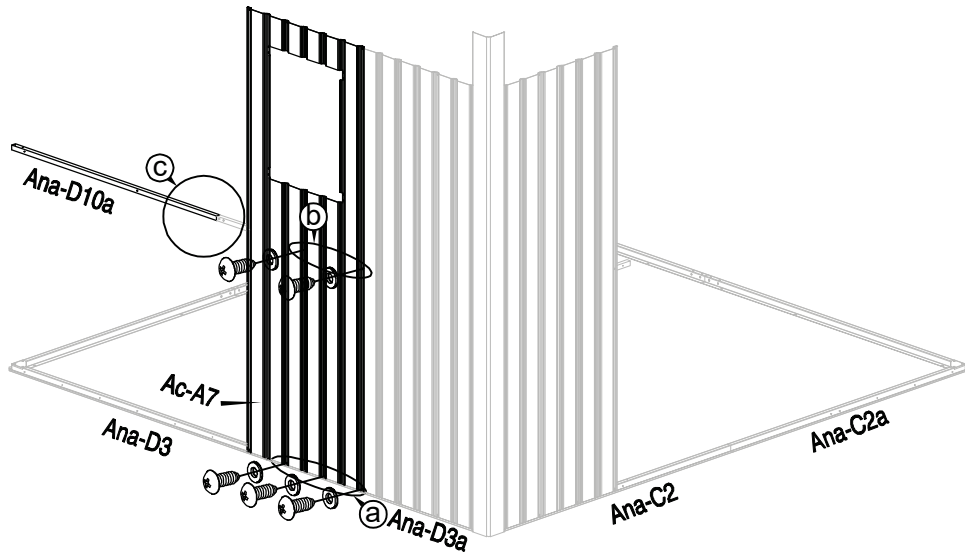

Ac-A7 x1



Ana-D10a x1

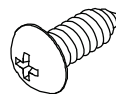

Anx-D41 x9



Anx-D40 x5

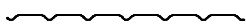
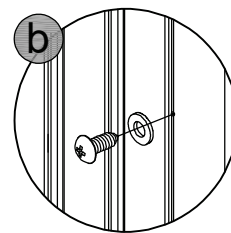
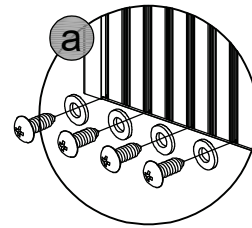
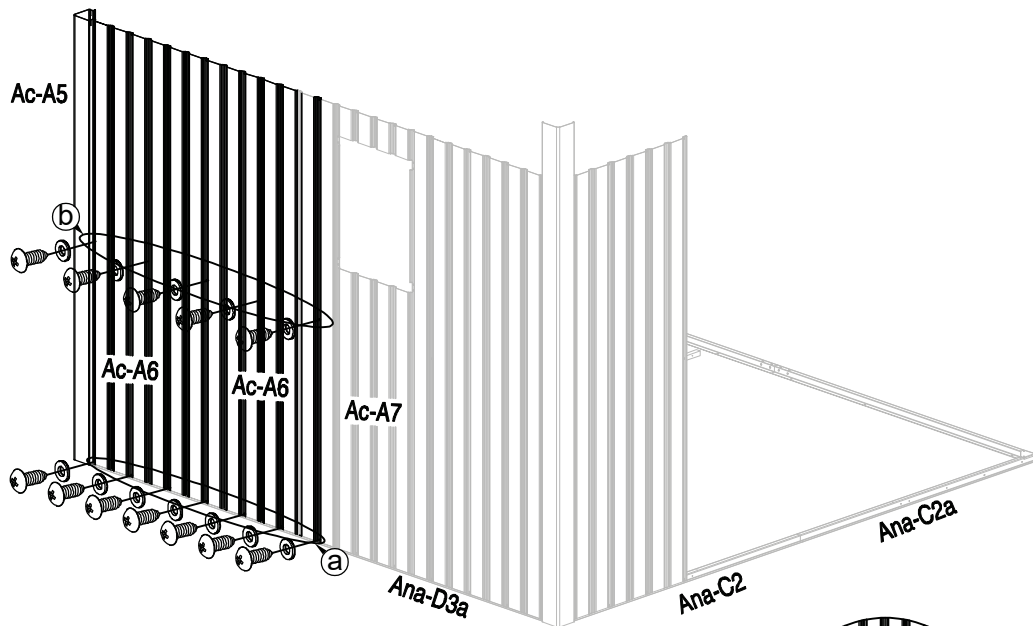

Ac-A6 x2



Ac-A5 x1

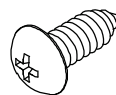

Anx-D41 x12



Anx-D40 x12

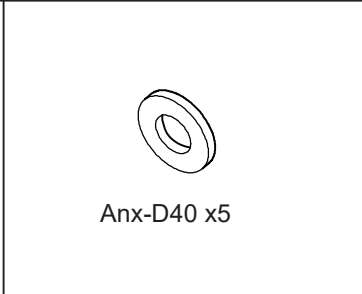
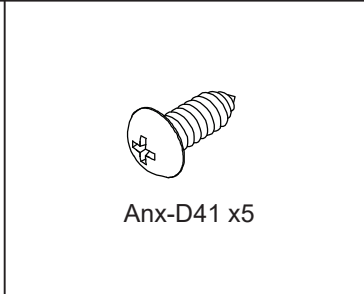
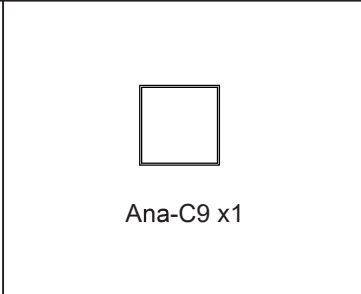
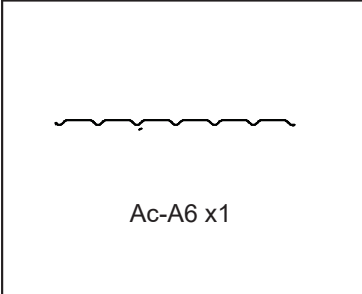
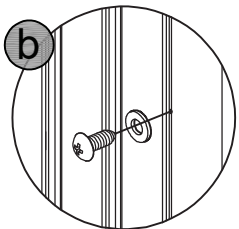
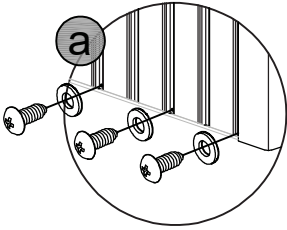
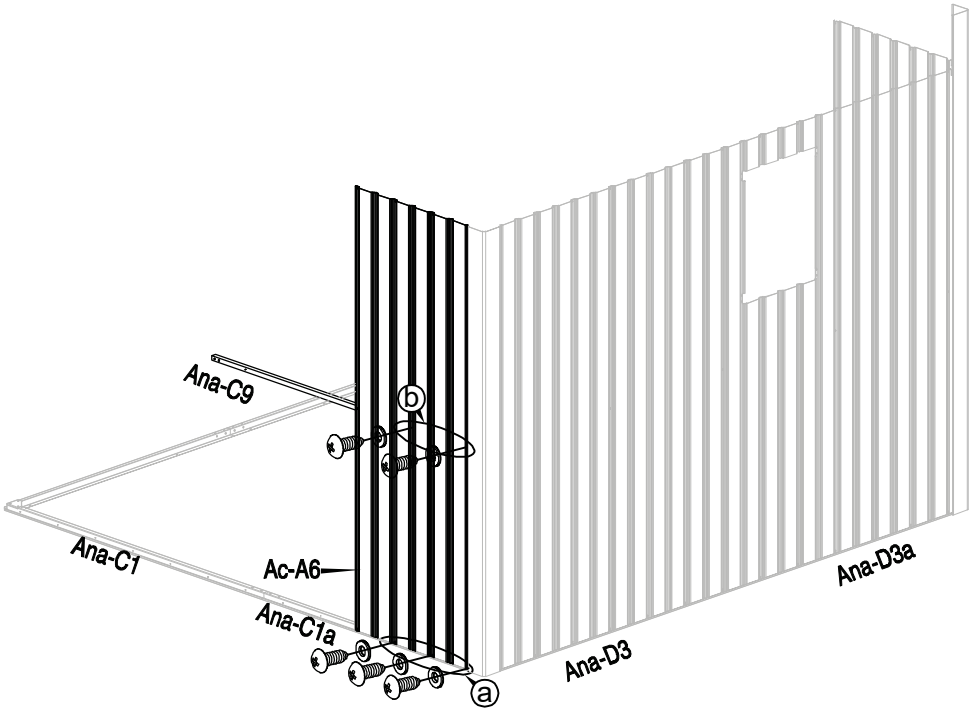

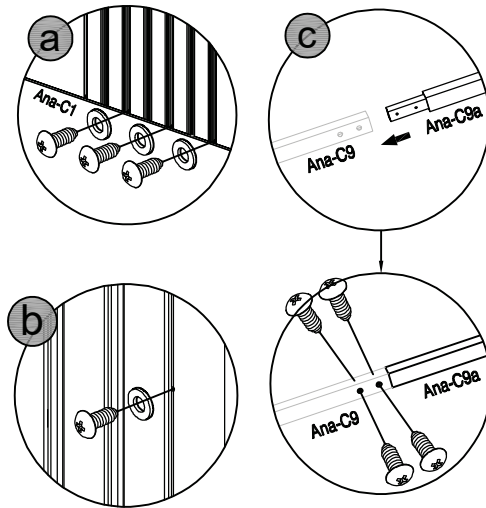
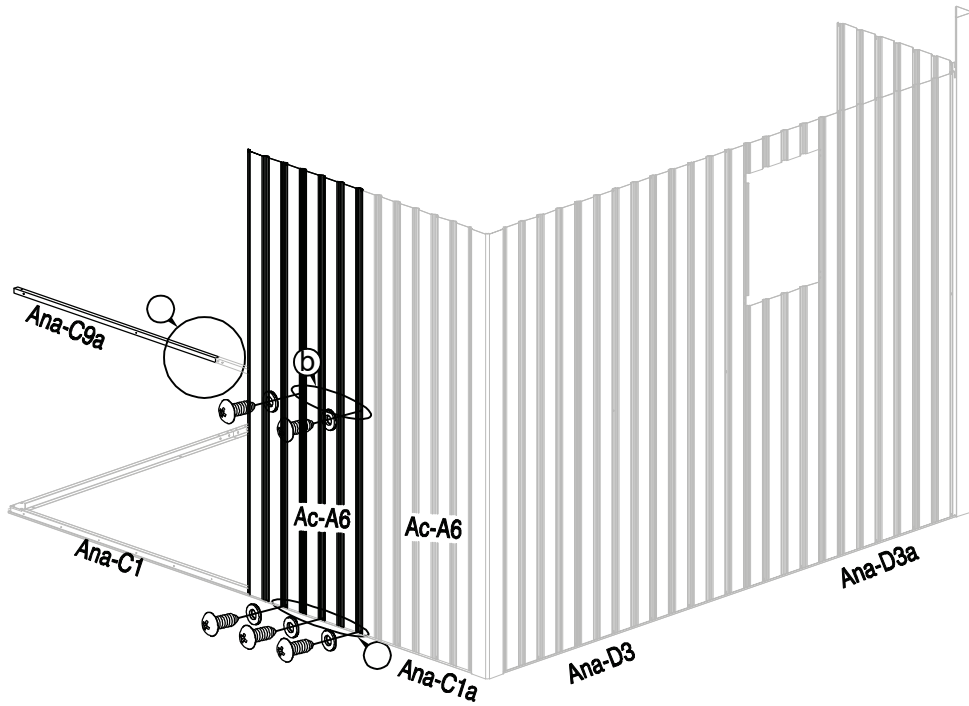

Ac-A6 x1



Ana-C9a x1



Anx-D41 x5



Anx-D40 x5

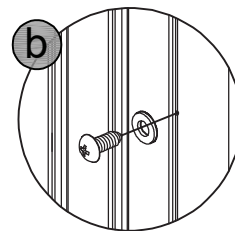
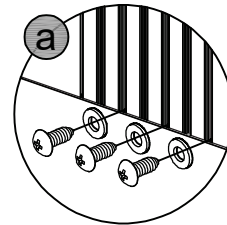
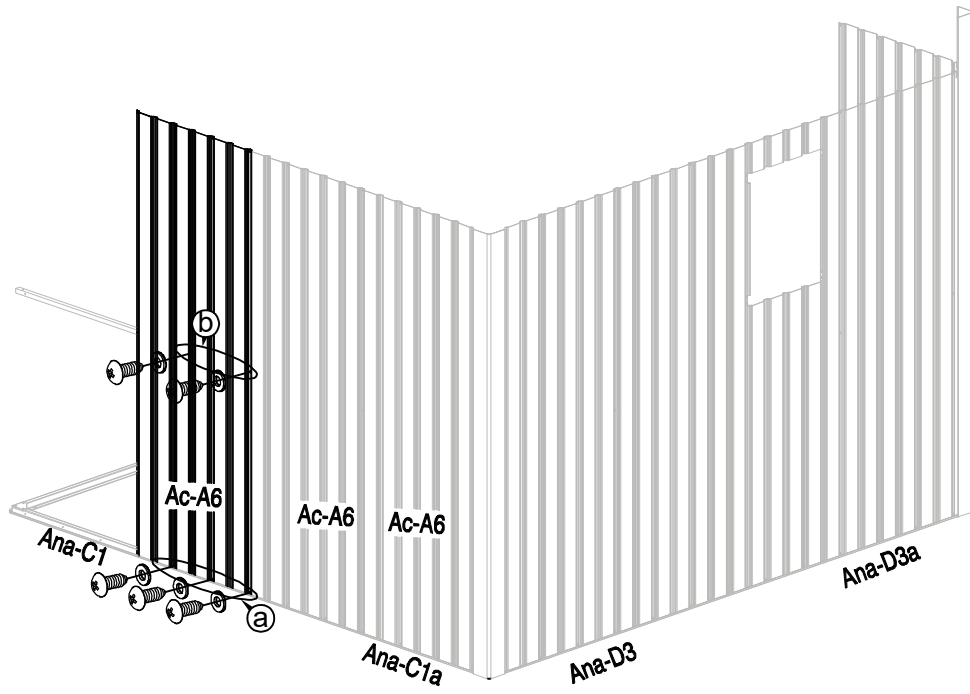

Ac-A6 x1

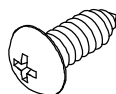

Anx-D41 x5



Anx-D40 x5

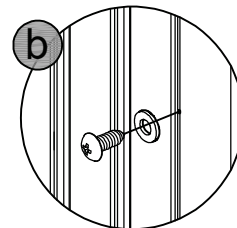
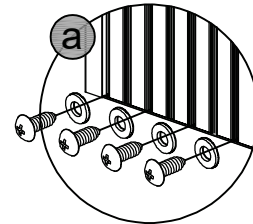
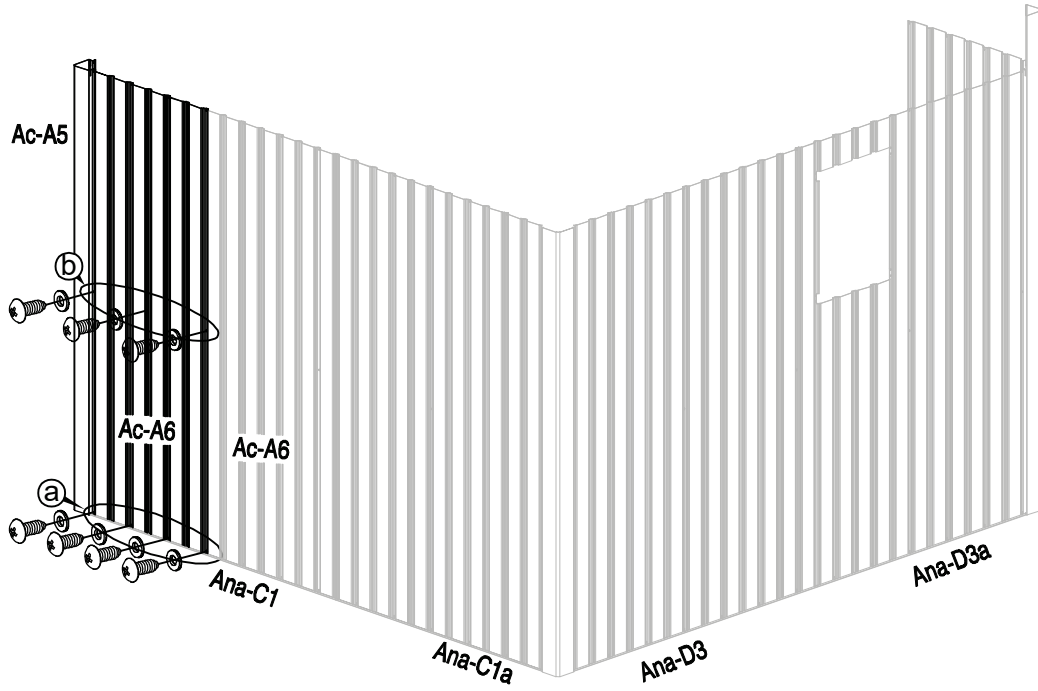

Ac-A6 x1



Ac-A5 x1

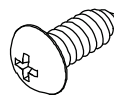





Anx-D41 x7

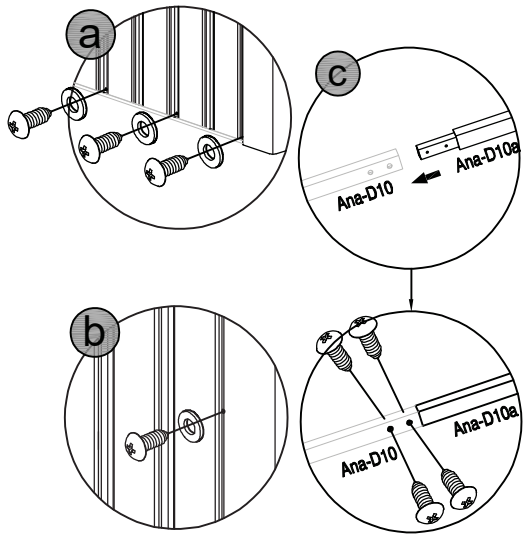
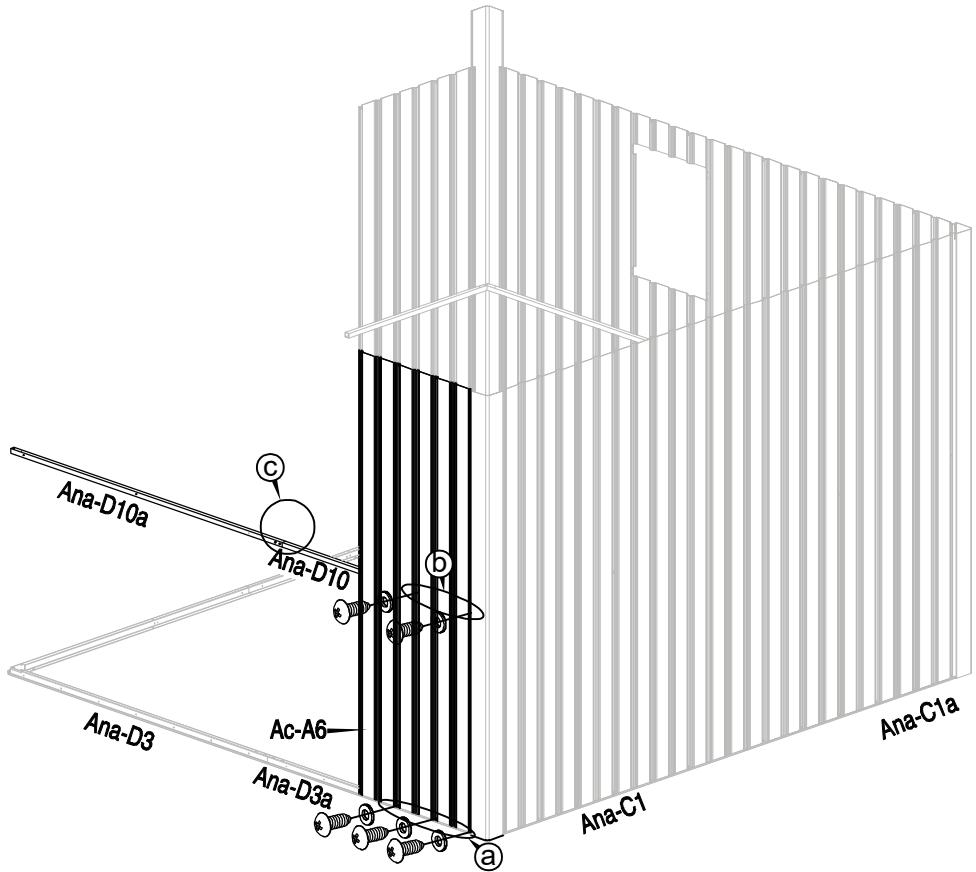

Anx-D40 x7



 Ac-A6 x1	 Ana-D10 x1	 Ana-D10a x1	 Anx-D41 x9	 Anx-D40 x5
---	---	--	---	---

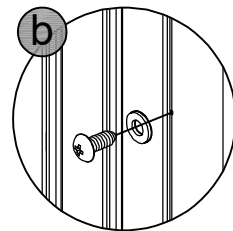
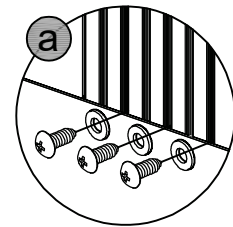
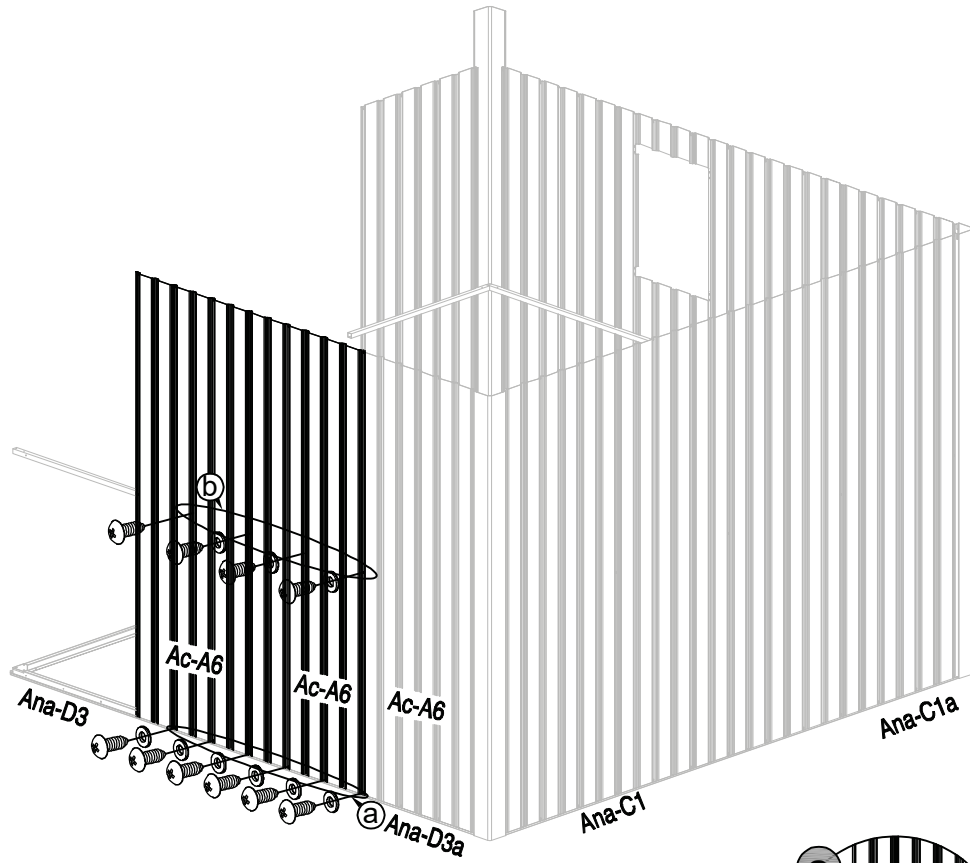

Ac-A6 x2

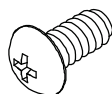



Anx-D41 x10



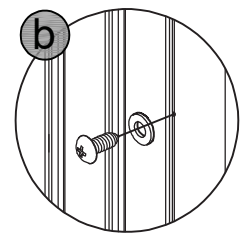
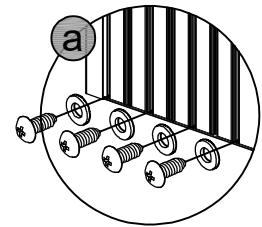
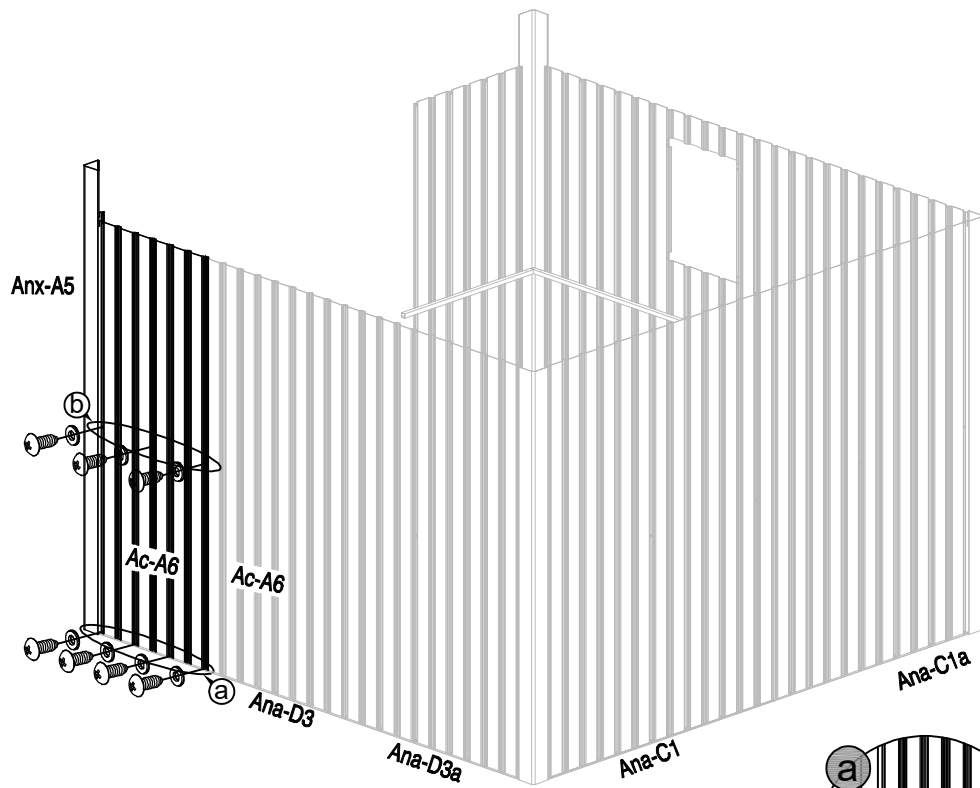

Anx-D40 x10



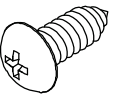

Ac-A6 x1

Anx-A5 x1

Anx-D41 x7

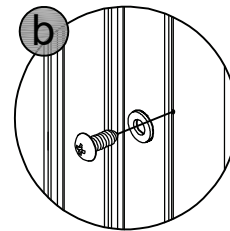
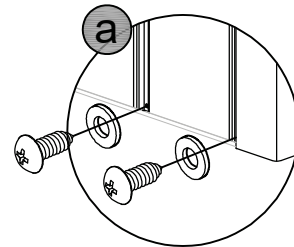
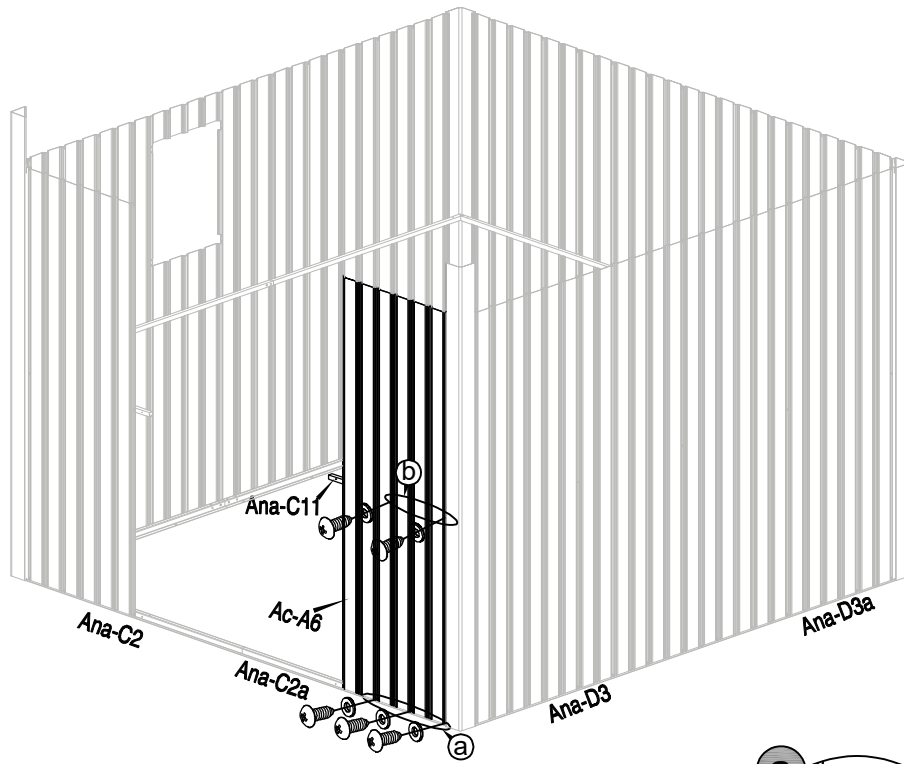

Anx-D40 x7



Ac-A6 x1

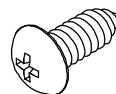

Ana-C11 x1



Anx-D41 x5



Anx-D40 x5

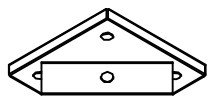
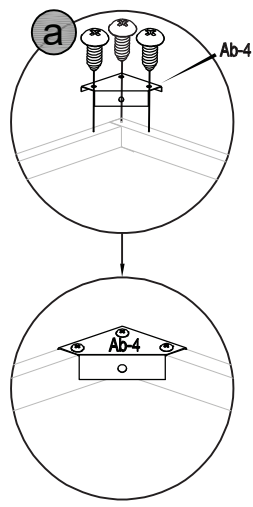
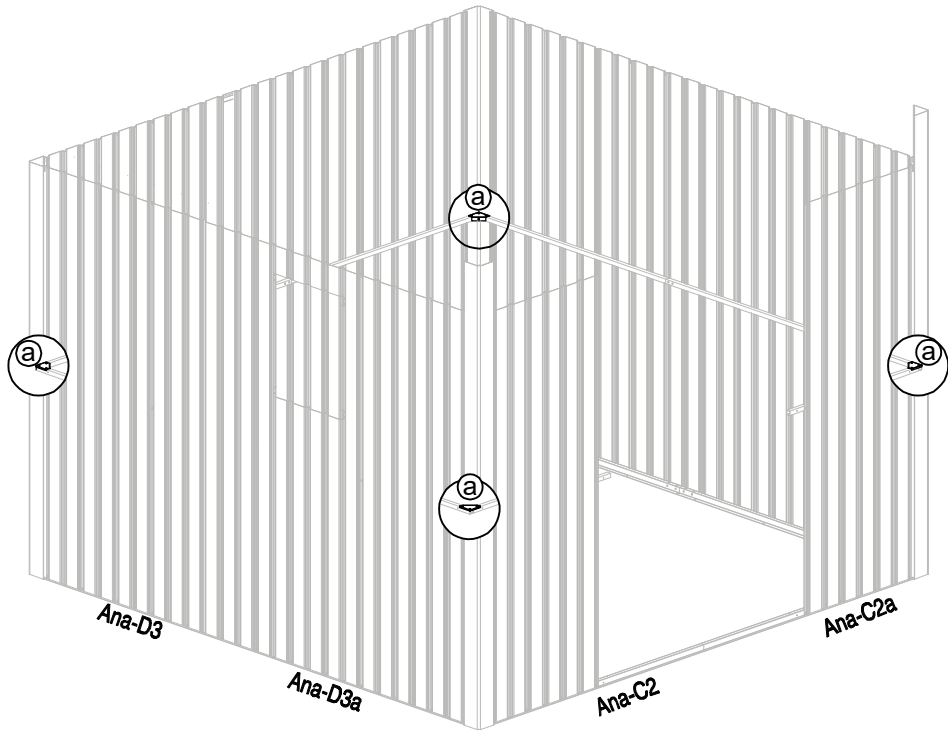

Ab-4 x4



Anx-D41 x12

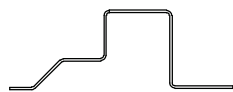
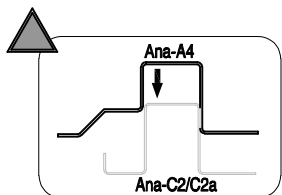
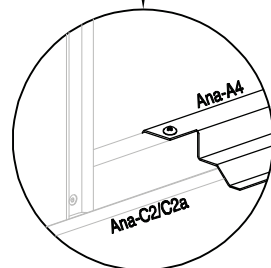
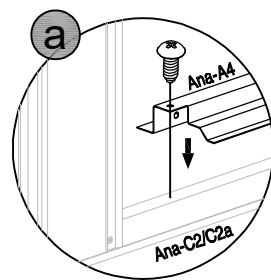
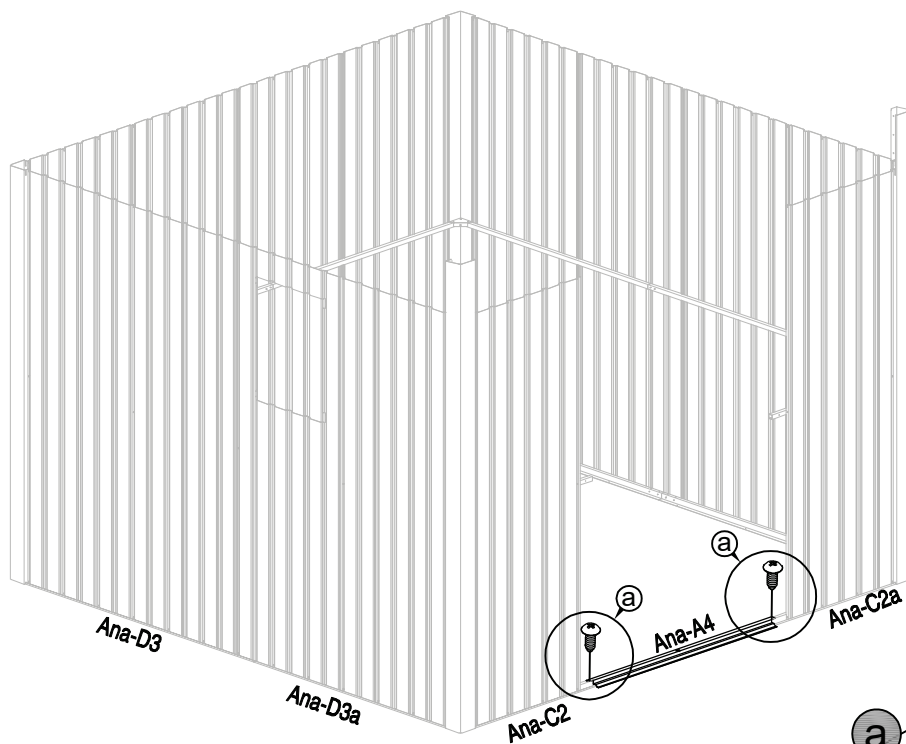



Ana-A4 x1

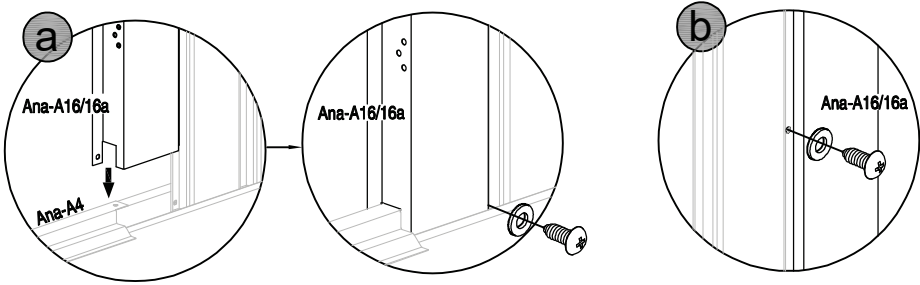
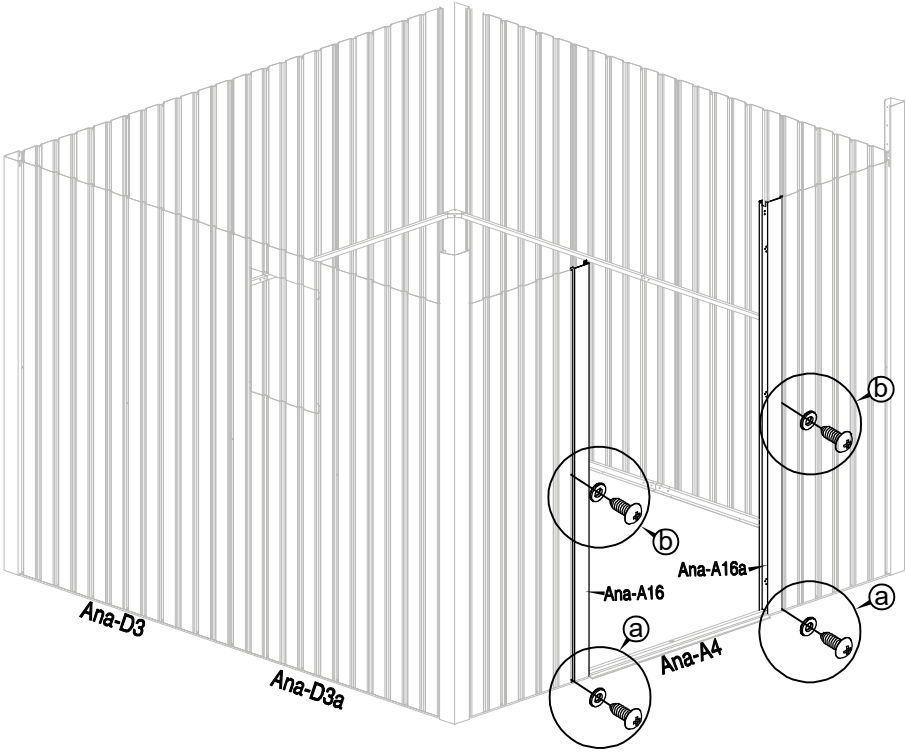

Anx-D41 x2

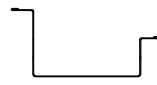
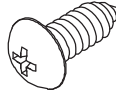



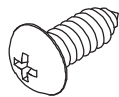
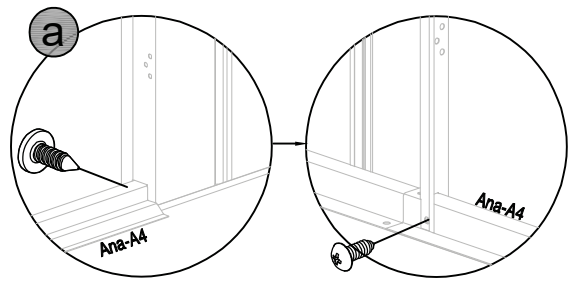
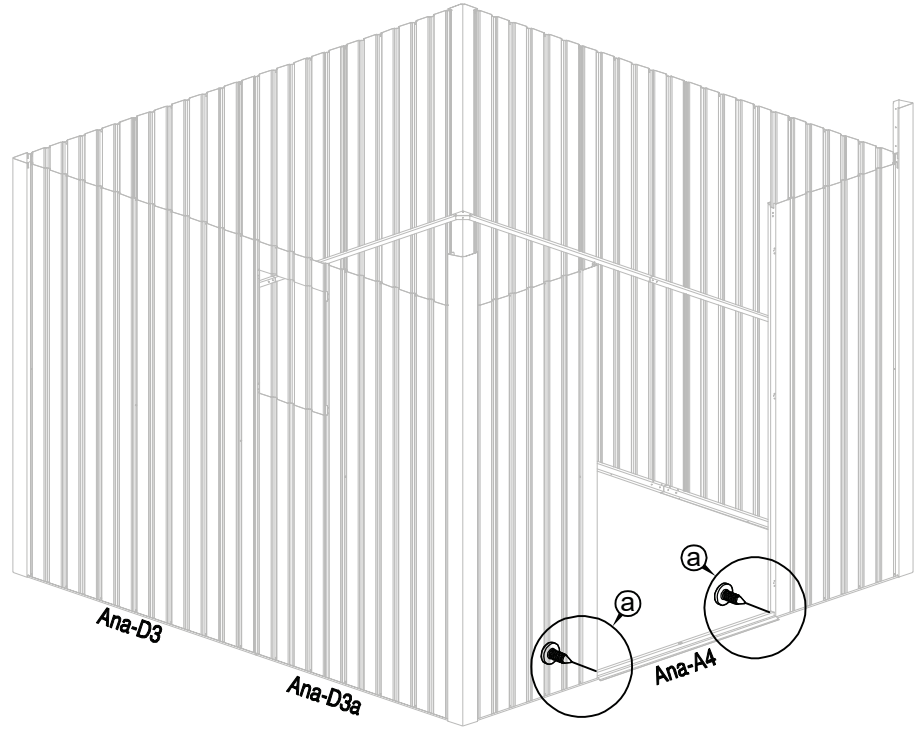

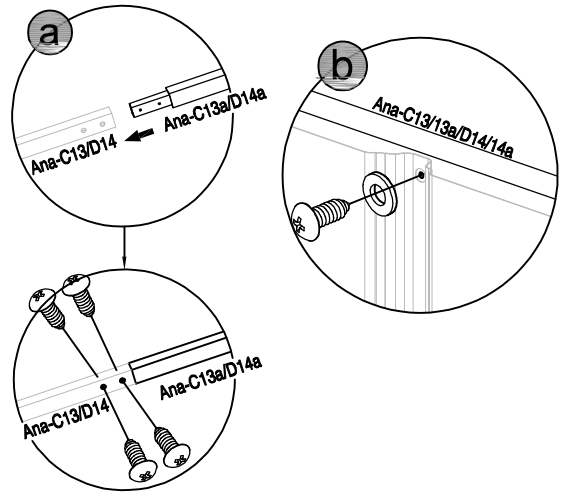
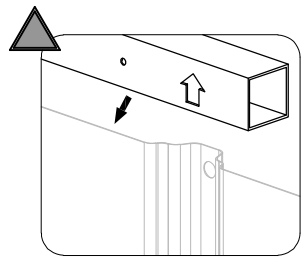
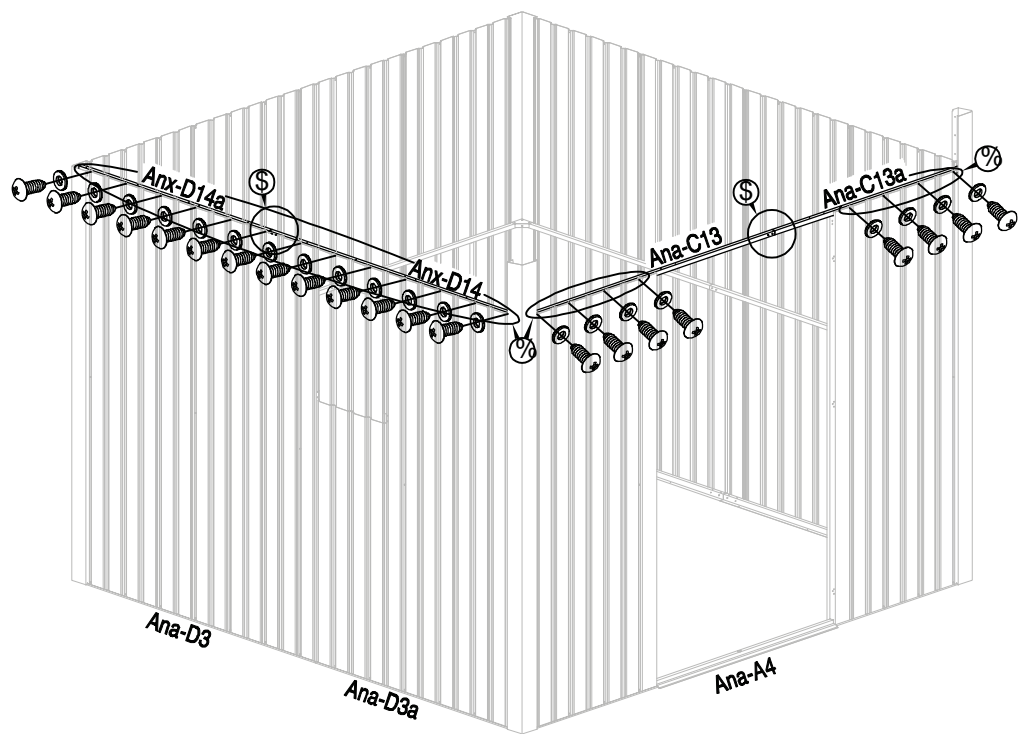

 <p>Ana-A16 x1</p>	 <p>Ana-A16a x1</p>	 <p>Anx-D41 x4</p>	 <p>Anx-D40 x4</p>
---	--	--	---



Anx-D41 x2



 <p>Ana-C13 x1</p>	 <p>Ana-C13a x1</p>	 <p>Anx-D14 x1</p>	 <p>Anx-D14a x1</p>	 <p>Anx-D41 x29</p>	 <p>Anx-D40 x21</p>
---	--	---	--	--	--

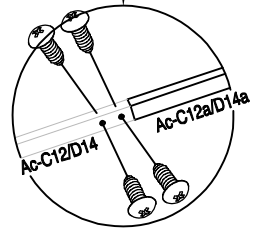
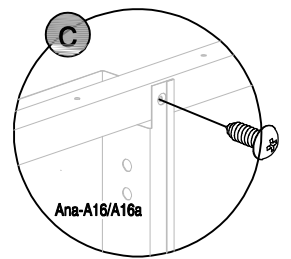
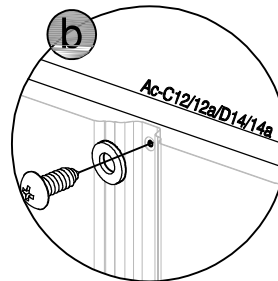
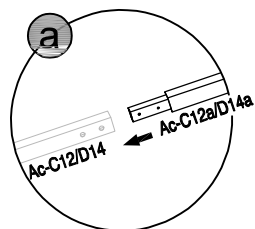
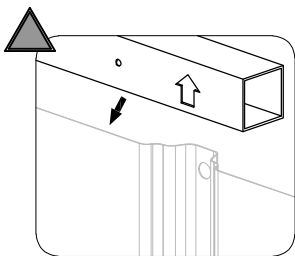
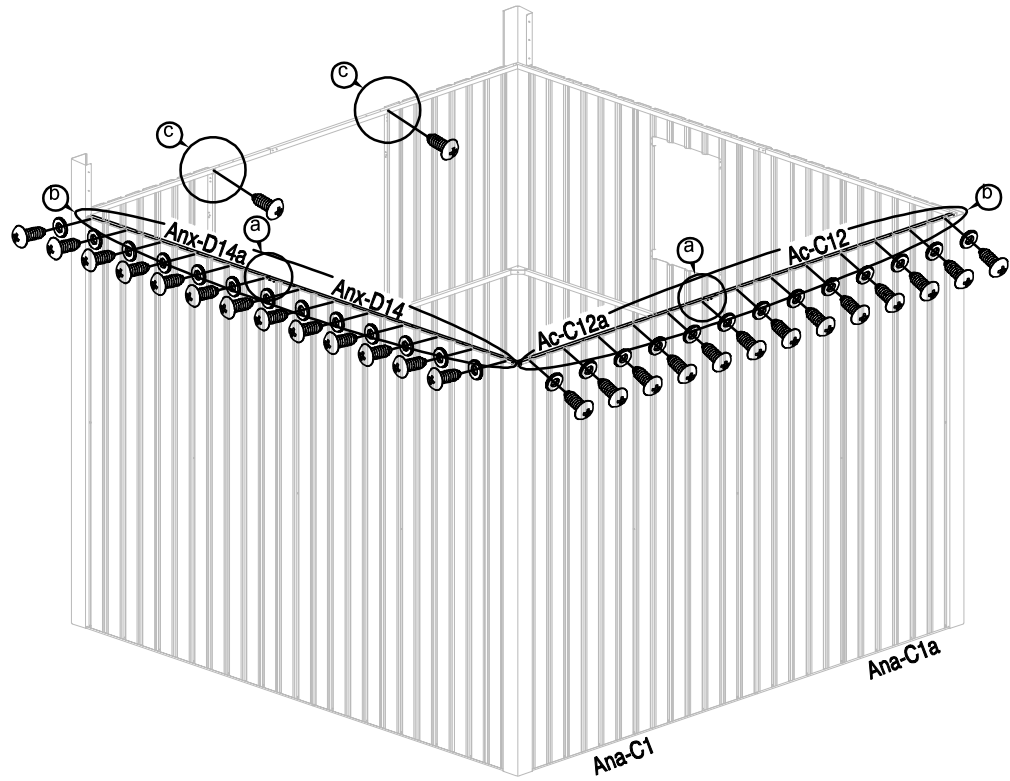

Ac-C12 x1



Ac-C12a x1



Anx-D14 x1



Anx-D14a x1



Anx-D41 x36



Anx-D40 x26

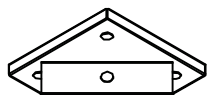
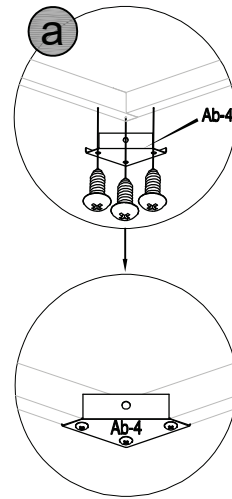
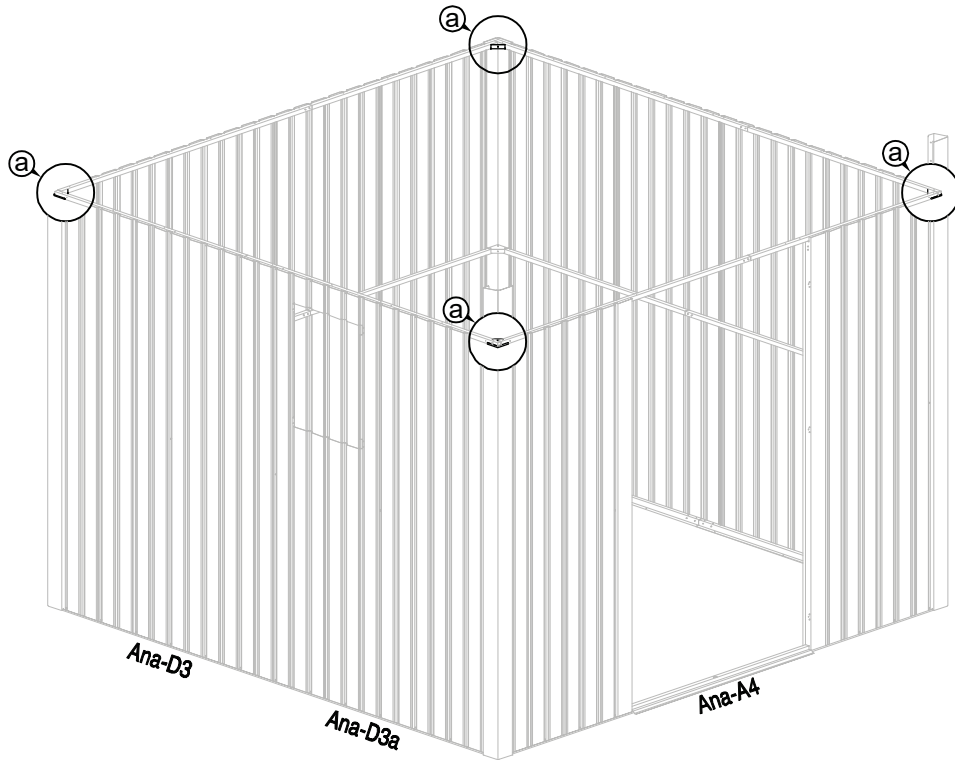

Ab-4 x4



Anx-D41 x12

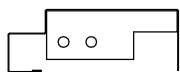
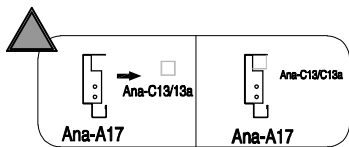
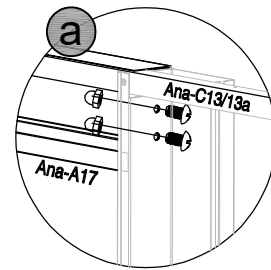
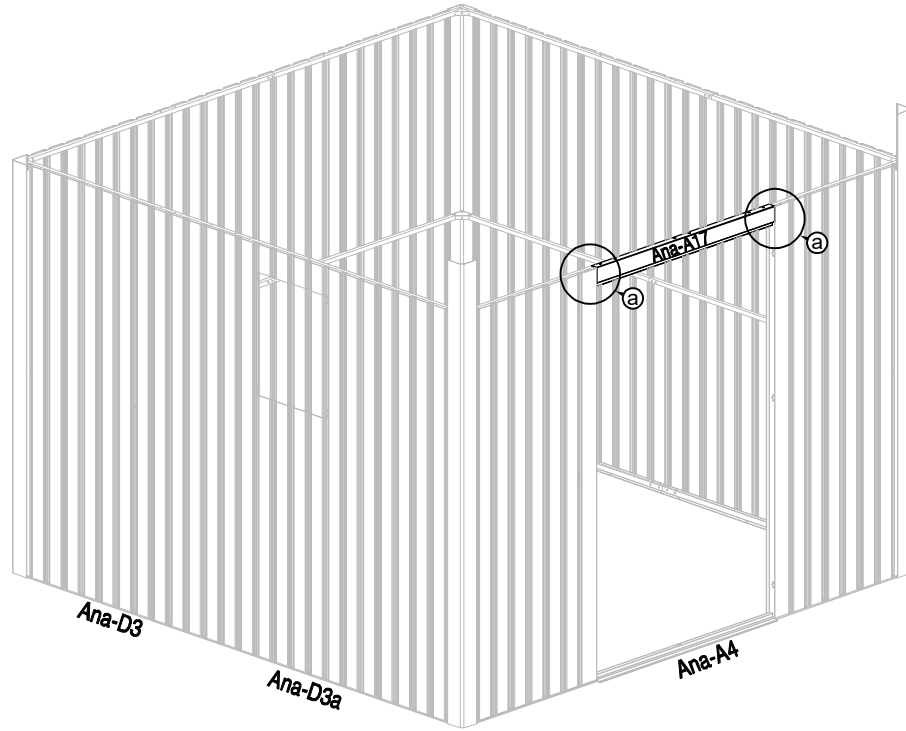

Ana-A17 x1

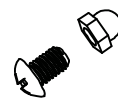

Anx-A44 x4

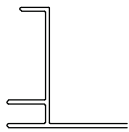
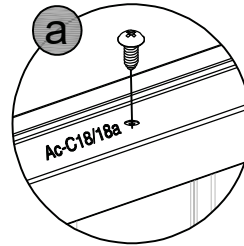
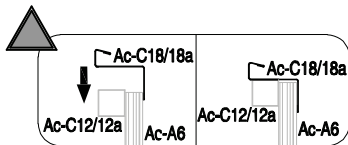
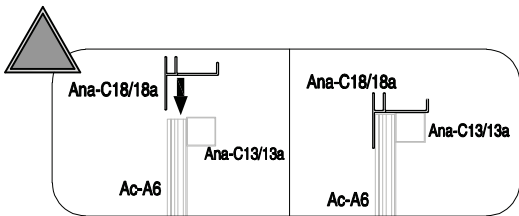
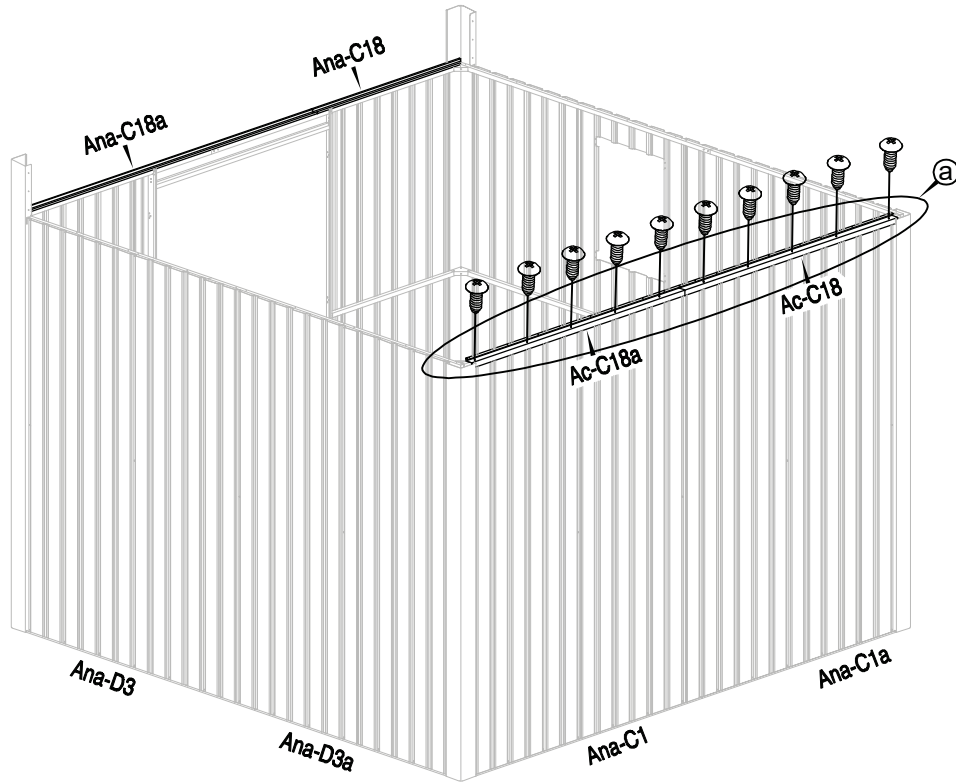

Ana-C18 x1

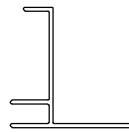

Ana-C18a x1

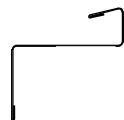

Ac-C18 x1

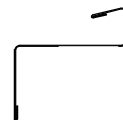

Ac-C18a x1



Anx-D41 x10

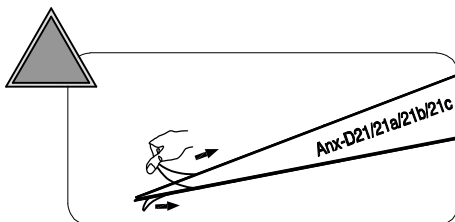
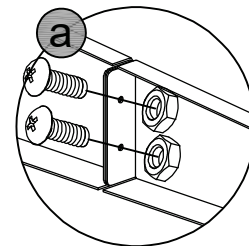
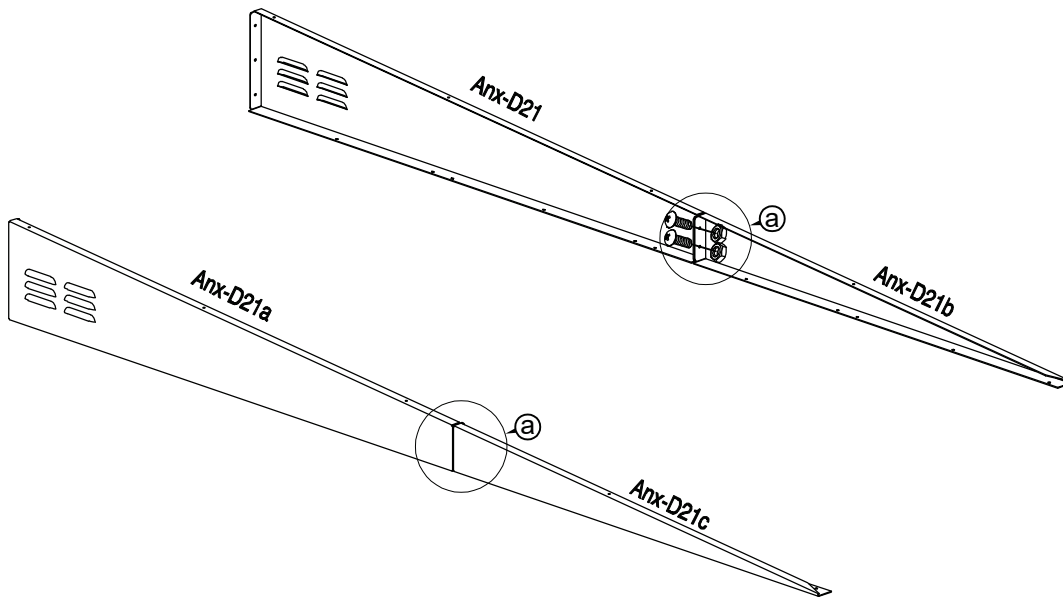

Anx-D21b x1



Anx-D21c x1



Anx-D21 x1







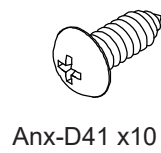
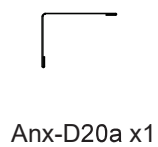
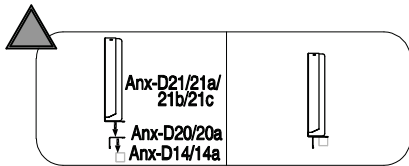
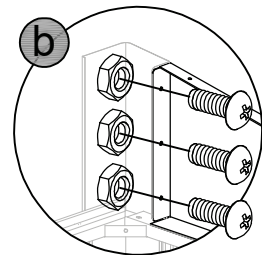
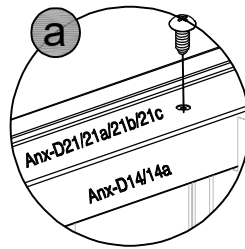
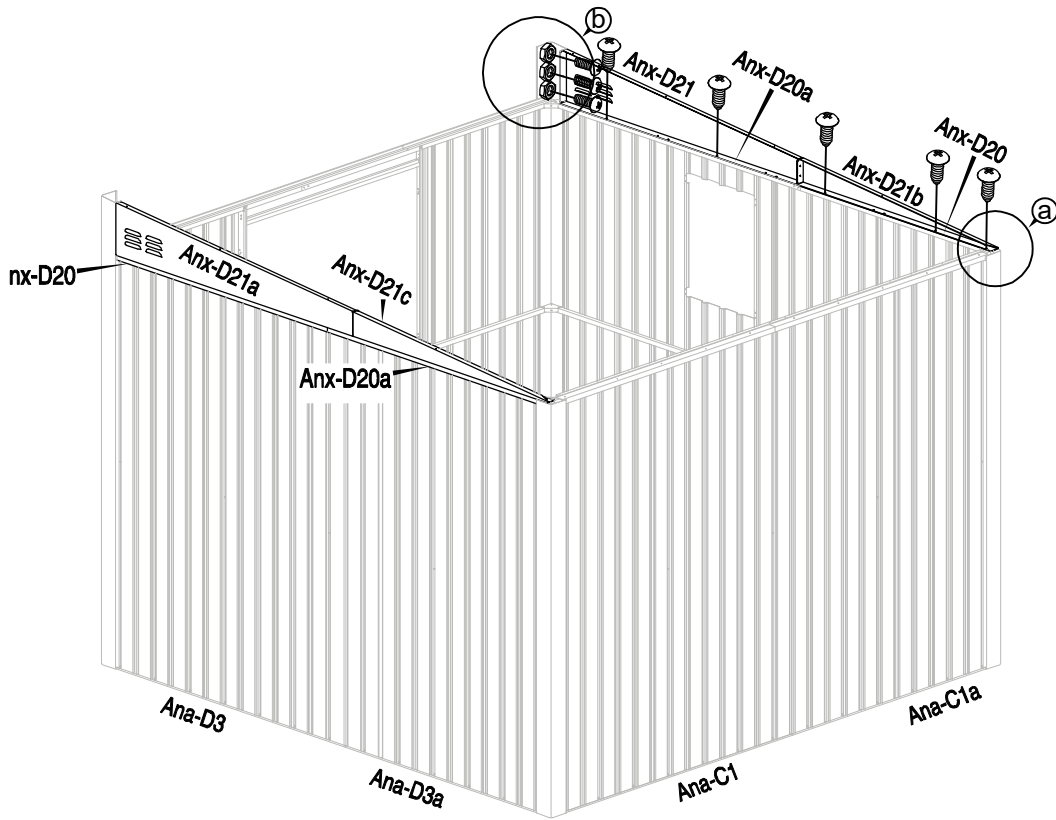

Anx-D21a x8

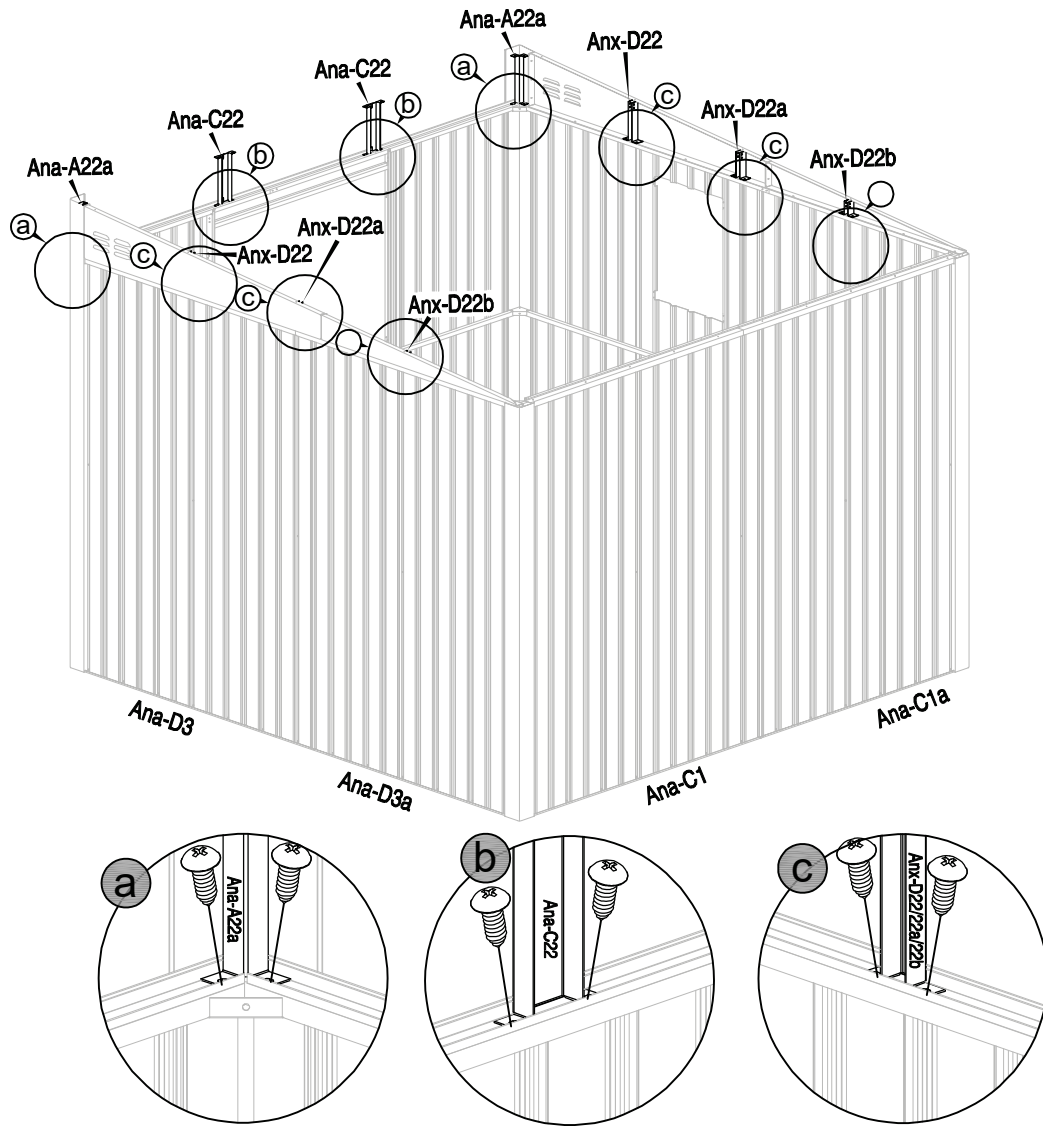

Anx-D46 x4





 <p>Anx-D22 x2</p>	 <p>Anx-D22a x2</p>	 <p>Anx-D22b x2</p>	 <p>Ana-C22 x2</p>	 <p>Ana-A22a x2</p>	 <p>Anx-D41 x20</p>
---	--	--	---	--	--

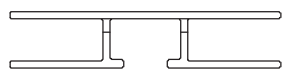
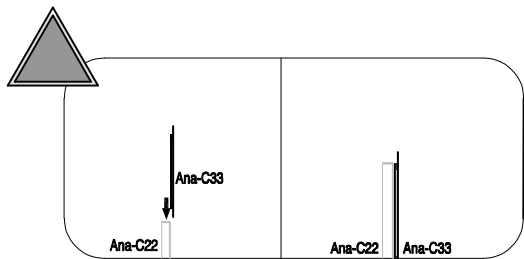
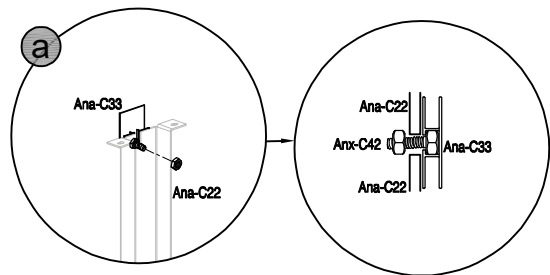
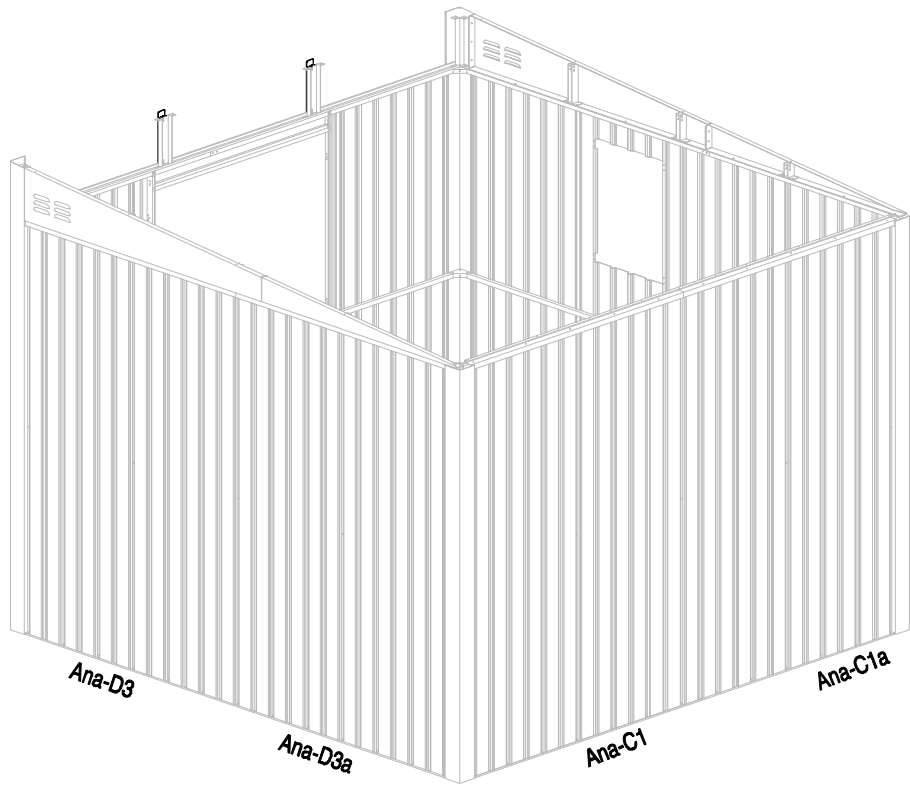

Ana-C33 x2

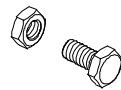

Anx-C42 x2

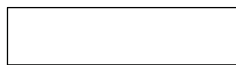
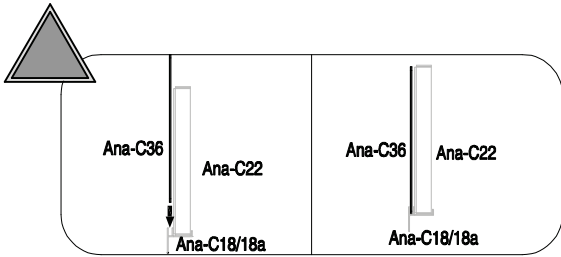
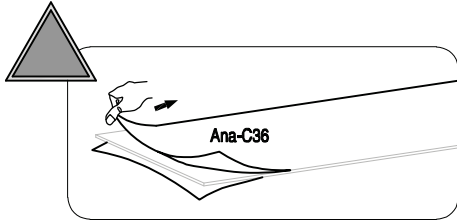
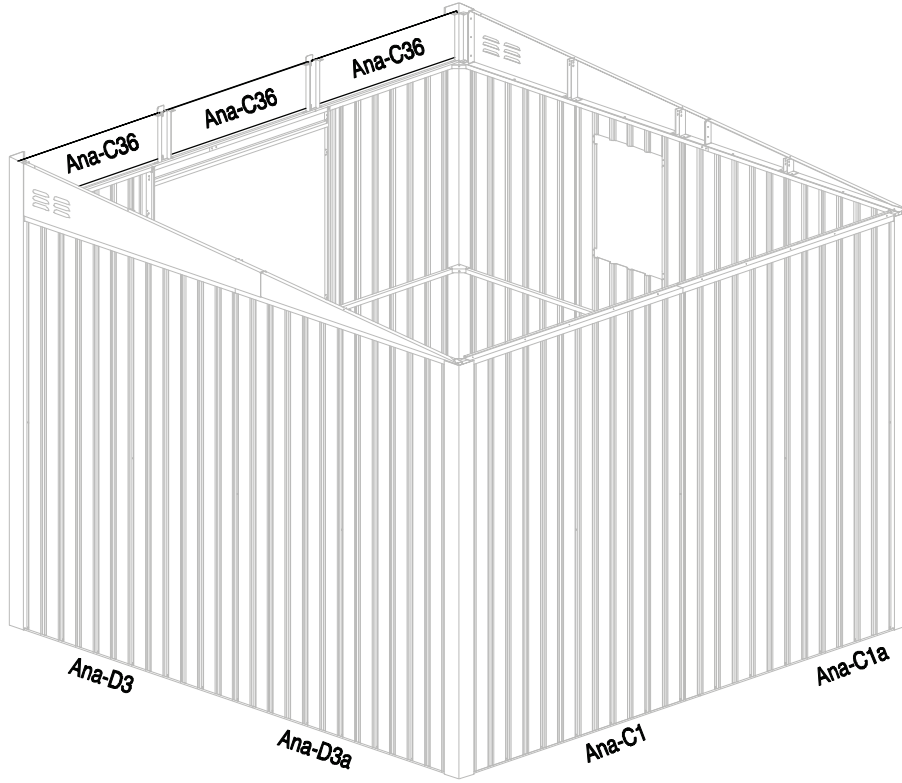

Ana-C36 x3

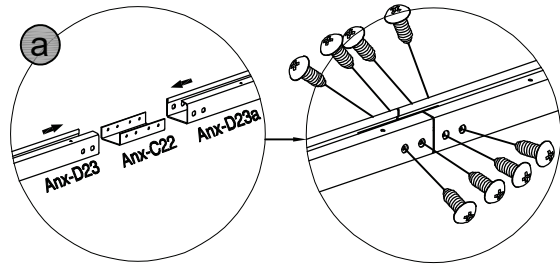
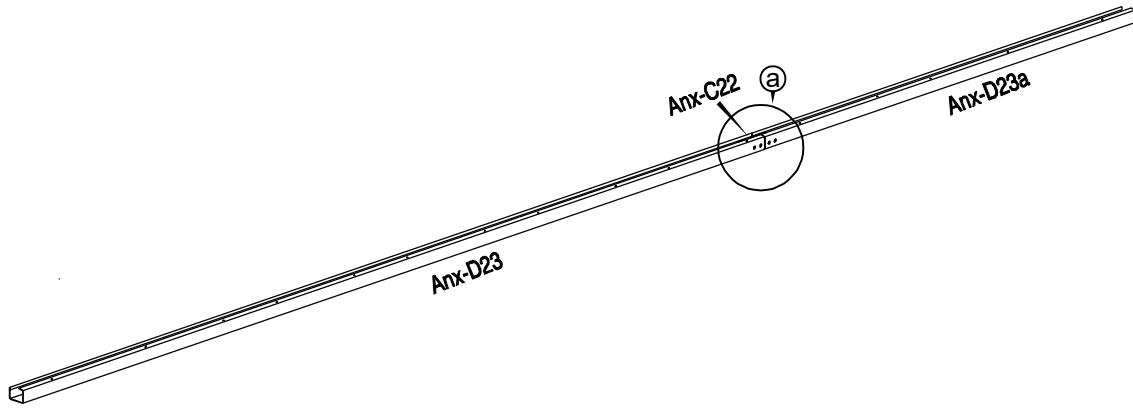

Anx-D23 x1



Anx-D23a x1



Anx-C22 x1

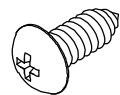

Anx-D41 x8

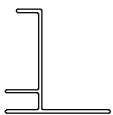
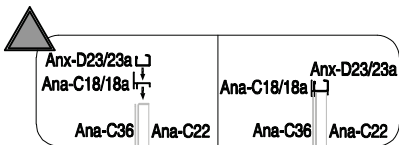
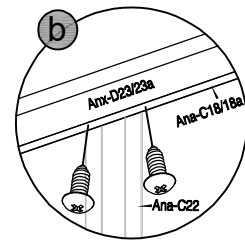
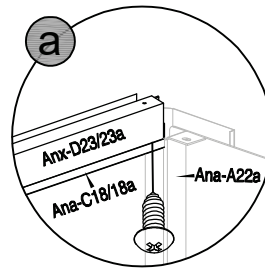
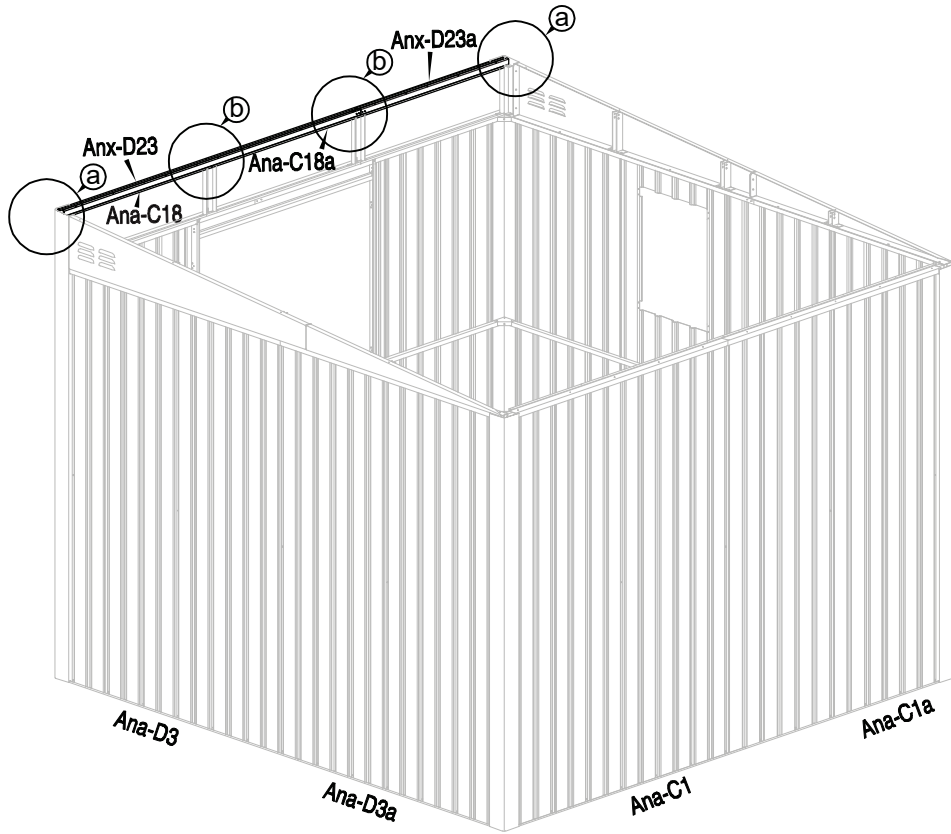

Ana-C18 x1

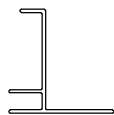

Ana-C18a x1

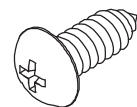

Anx-D41 x6

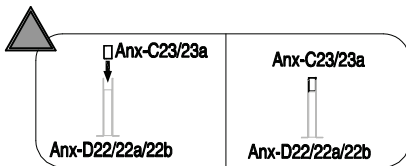
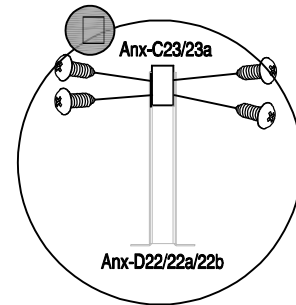
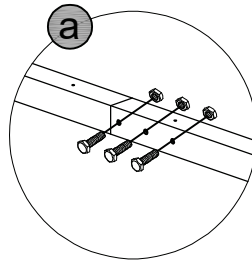
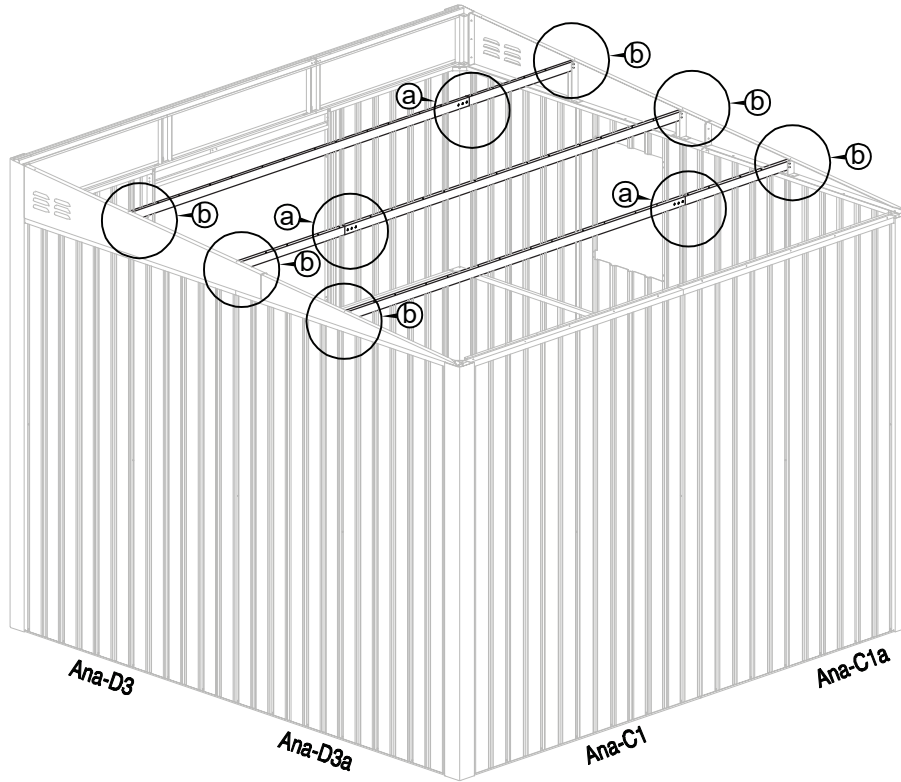

Anx-C23 x3



Anx-C23a x3

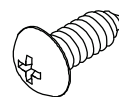

Anx-D41 x24

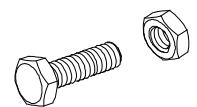

Anx-D48 x9

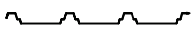
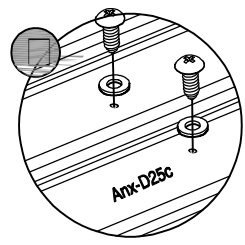
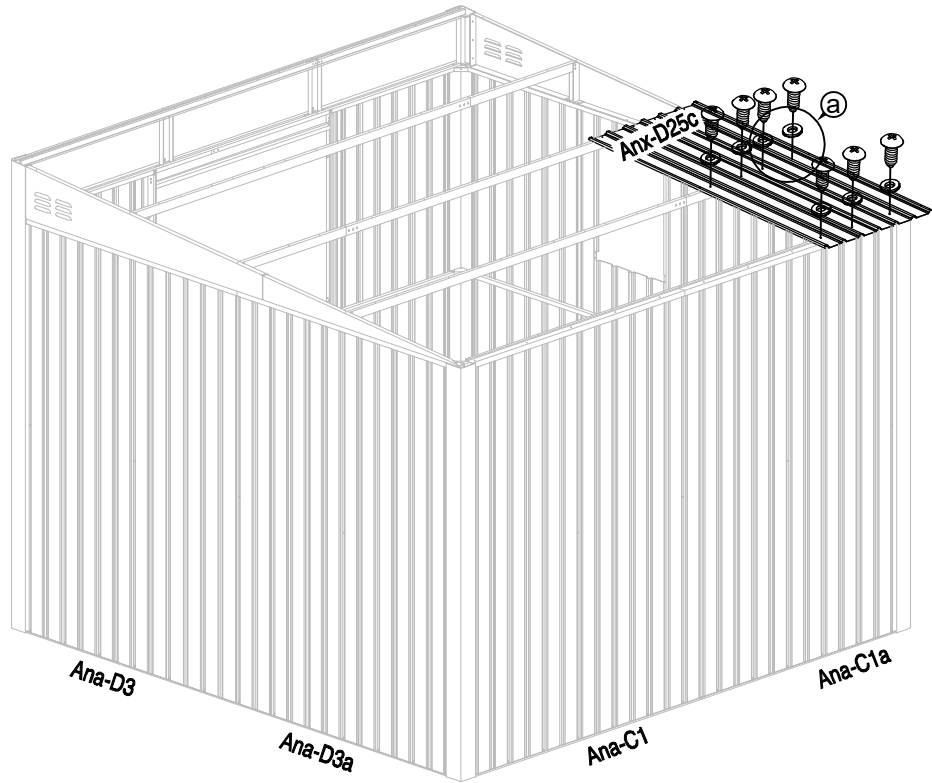

Anx-D25c x1

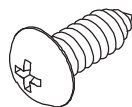

Anx-D41 x7



Anx-D40 x7

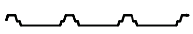
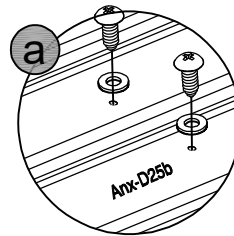
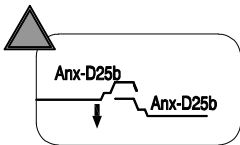
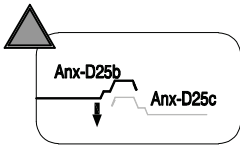
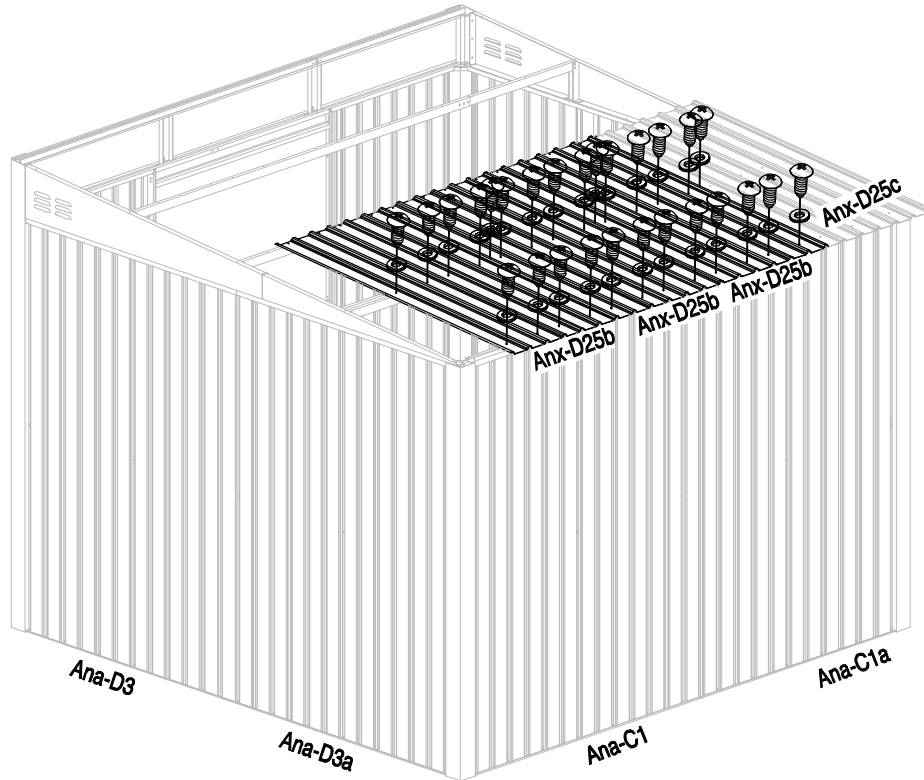

Anx-D25b x3

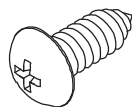

Anx-D41 x27



Anx-D40 x27

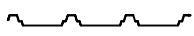
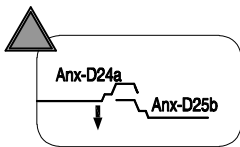
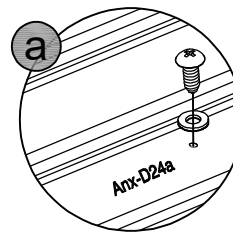
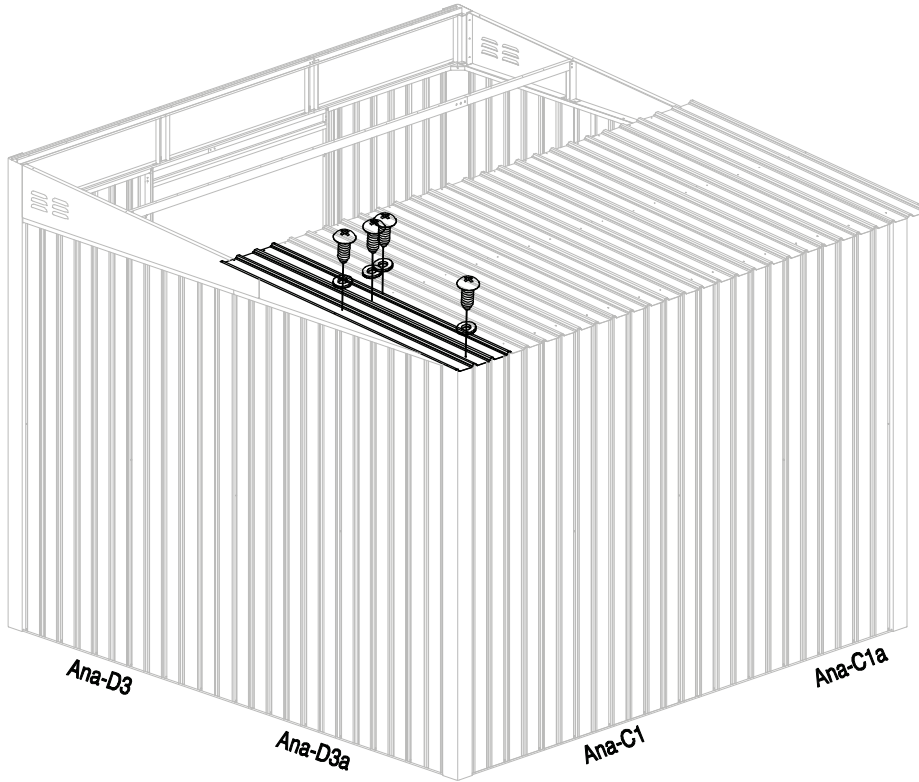

Anx-D24a x1

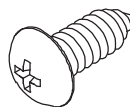

Anx-D41 x4



Anx-D40 x4

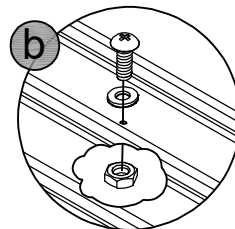
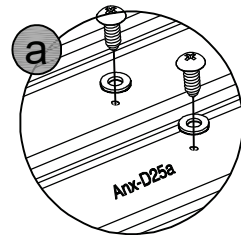
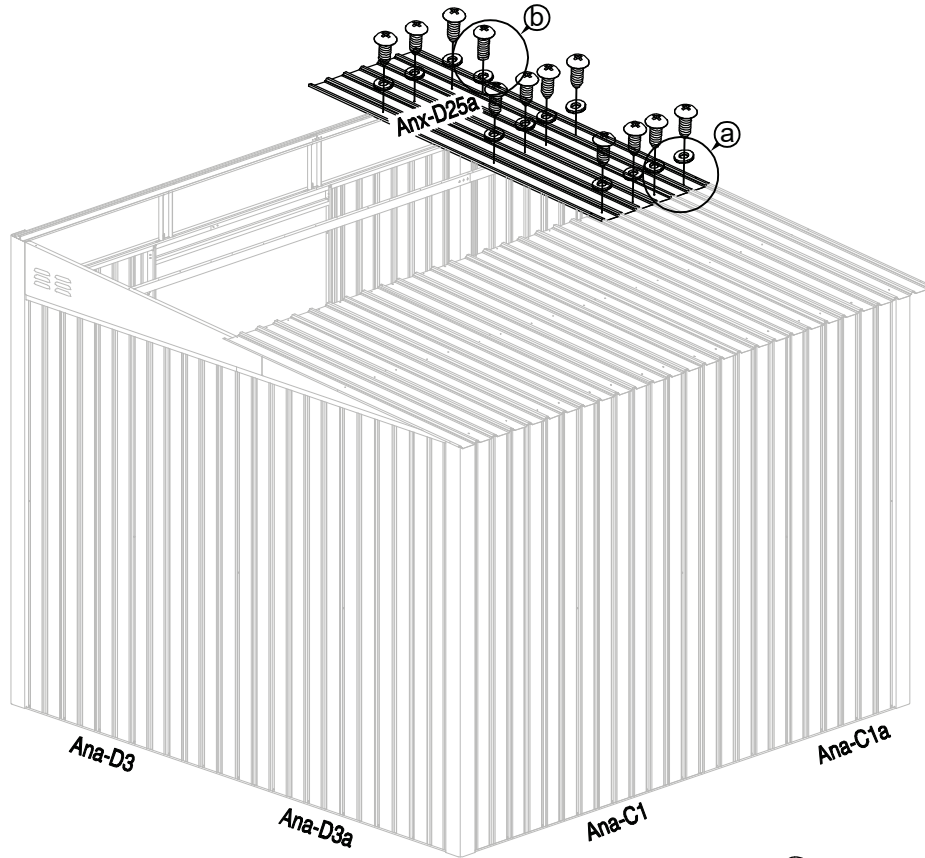

Anx-D25a x1

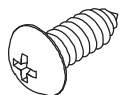

Anx-D41 x11



Anx-D40 x12

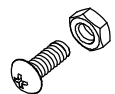

Anx-D46 x1

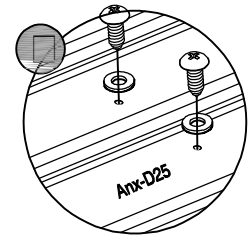
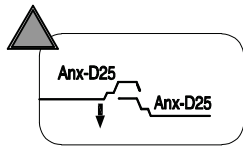
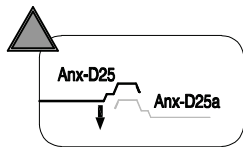
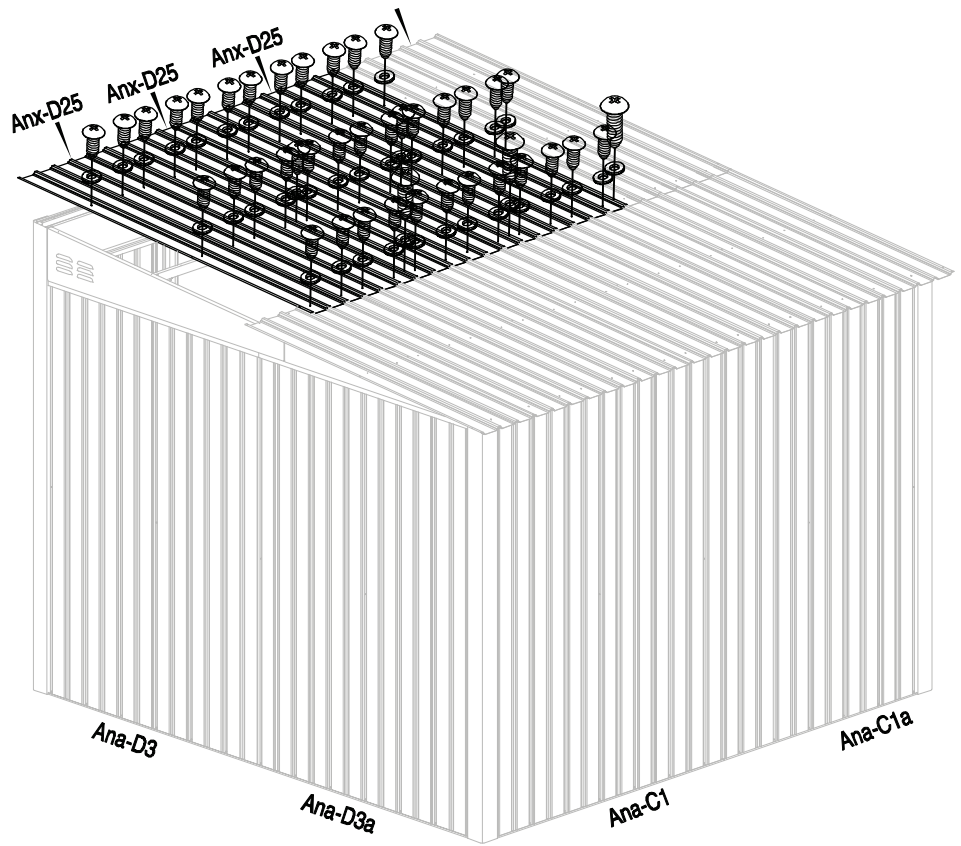

Anx-D25a x3

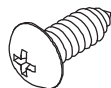

Anx-D41 x39





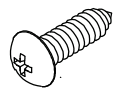

Anx-D40 x42

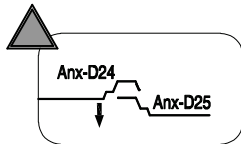
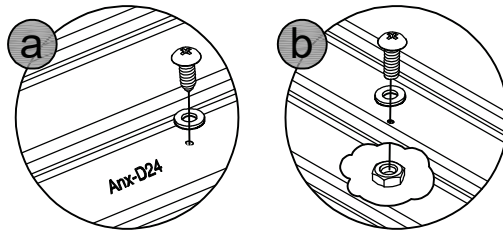
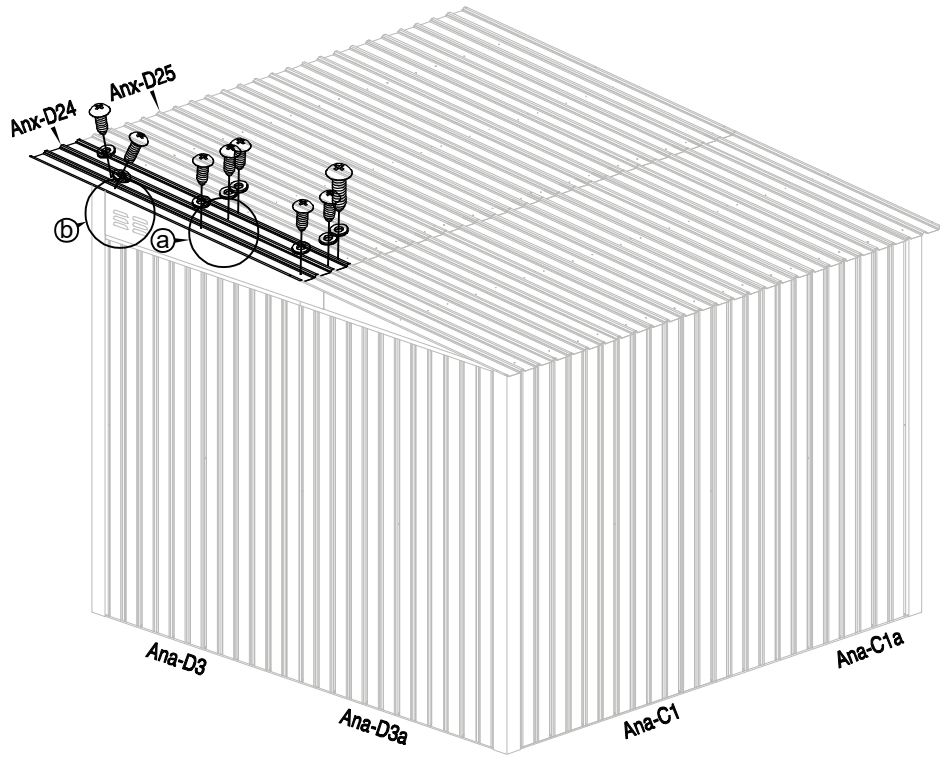

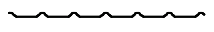



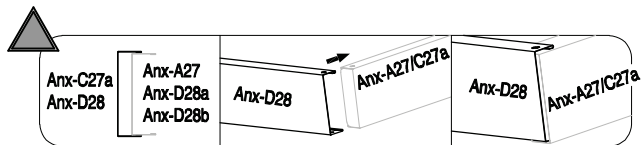
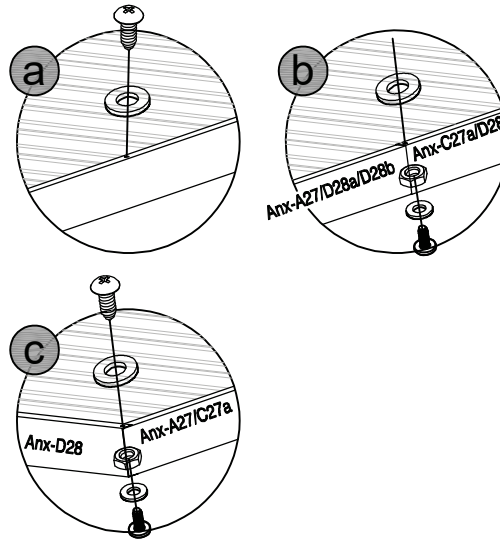
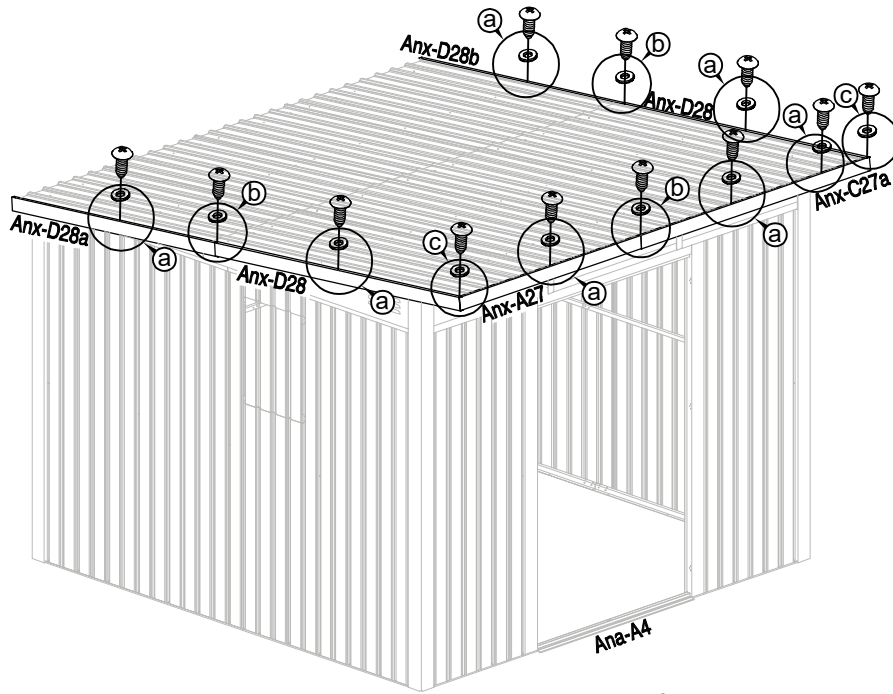

Anx-D47 x3

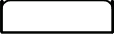



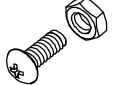

 <p>Anx-D24 x1</p>	 <p>Anx-D41 x6</p>	 <p>Anx-D40 x8</p>	 <p>Anx-D46 x1</p>	 <p>Anx-D47 x1</p>
---	---	---	---	---

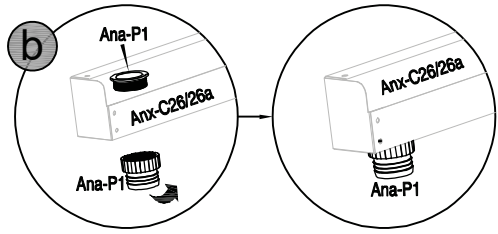
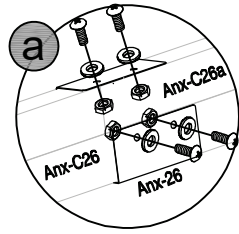
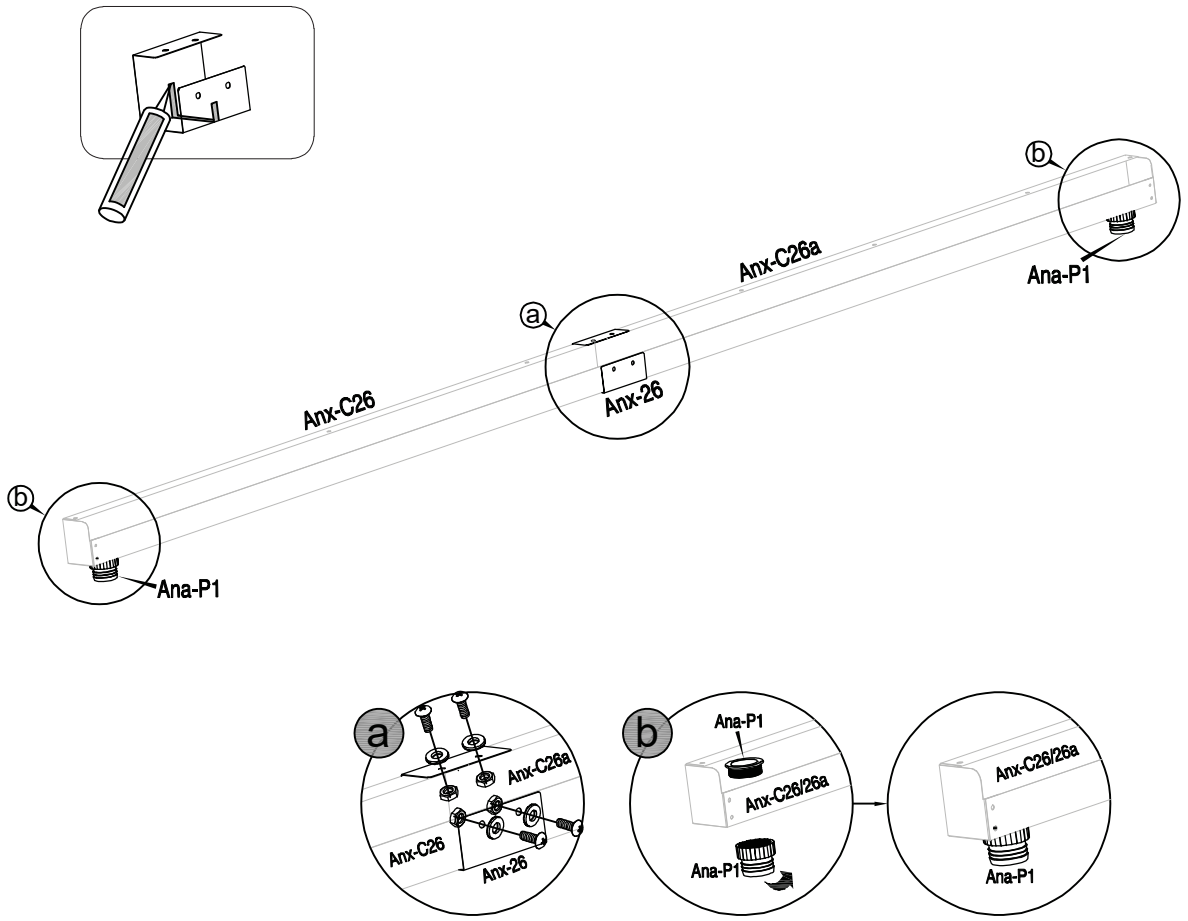

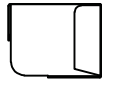
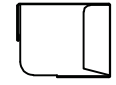
							
Anx-A27 x1	Anx-C27a x1	Anx-D28 x2	Anx-D28a x1	Anx-D28b x1	Anx-D41 x12	Anx-D40 x17	Anx-D46 x5



 <p>Anx-C26 x1</p>	 <p>Anx-C26a x1</p>	 <p>Anx-26 x1</p>	 <p>Ana-P1 x2</p>	 <p>Anx-D40 x4</p>	 <p>Anx-D46 x4</p>
---	--	--	--	---	---

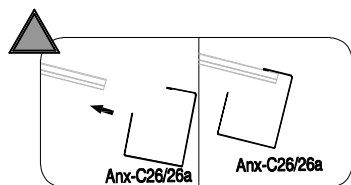
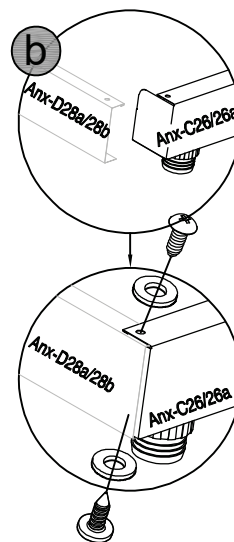
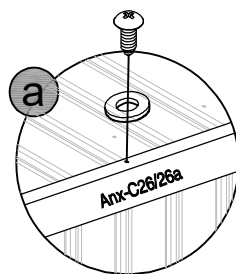
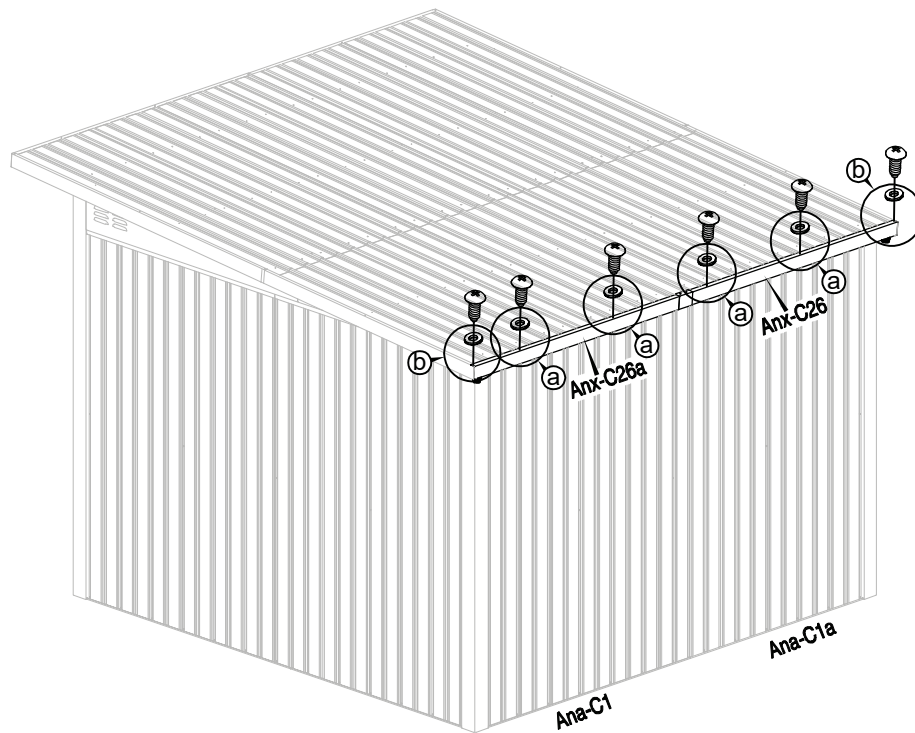

Anx-D40 x8

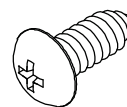

Anx-D41 x8

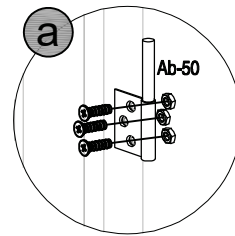
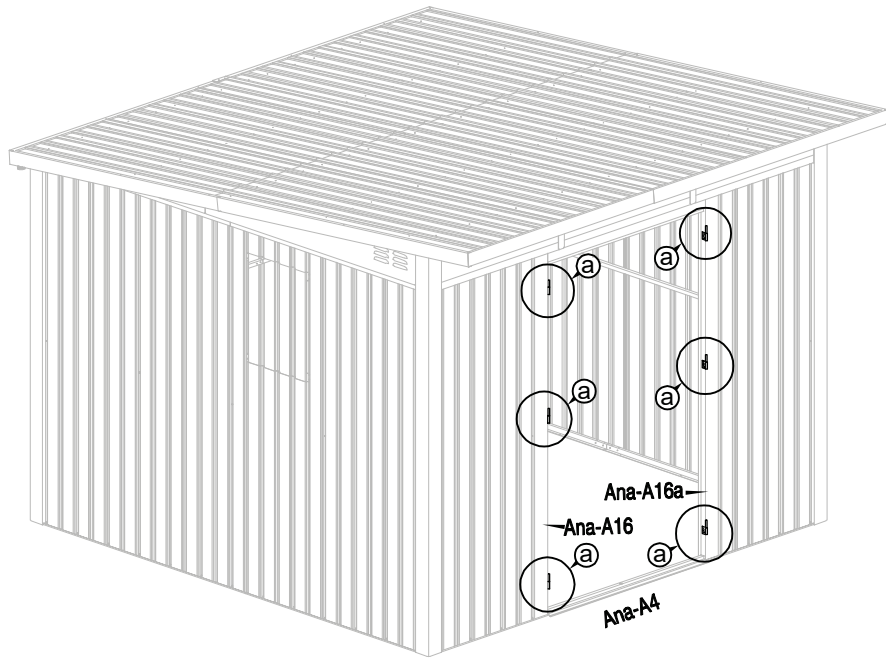

Ab-50 x6



Anx-A43 x18

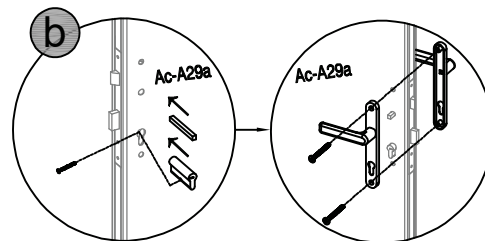
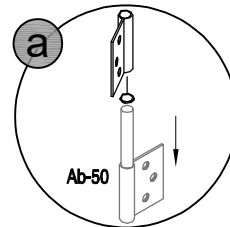
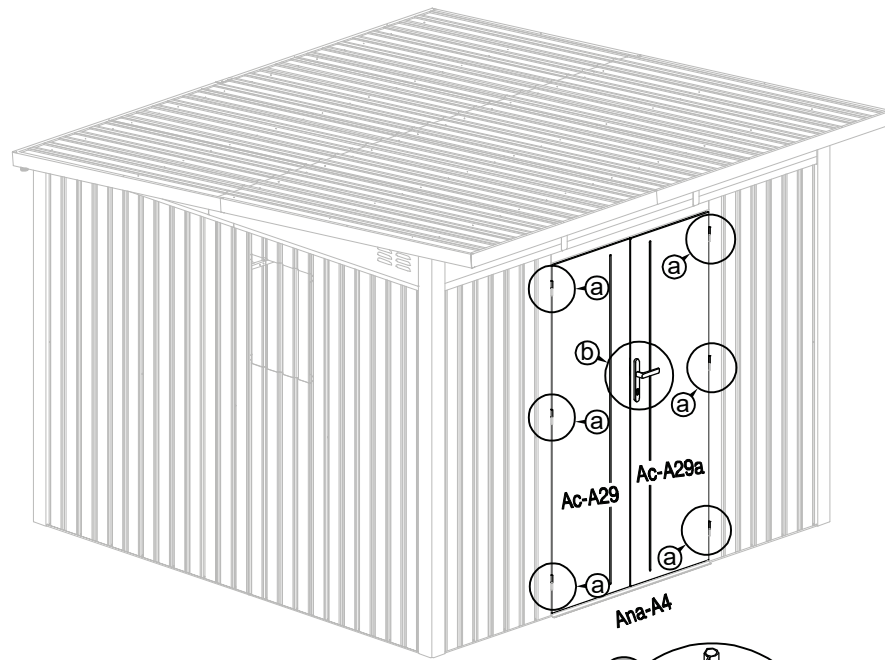

Ac-A29 x1



Ac-A29a x1



Ana-54 x1



Ana-55 x1



Ana-56 x1



Ana-57 x1



Ana-58 x3

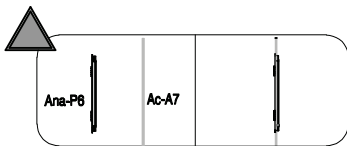
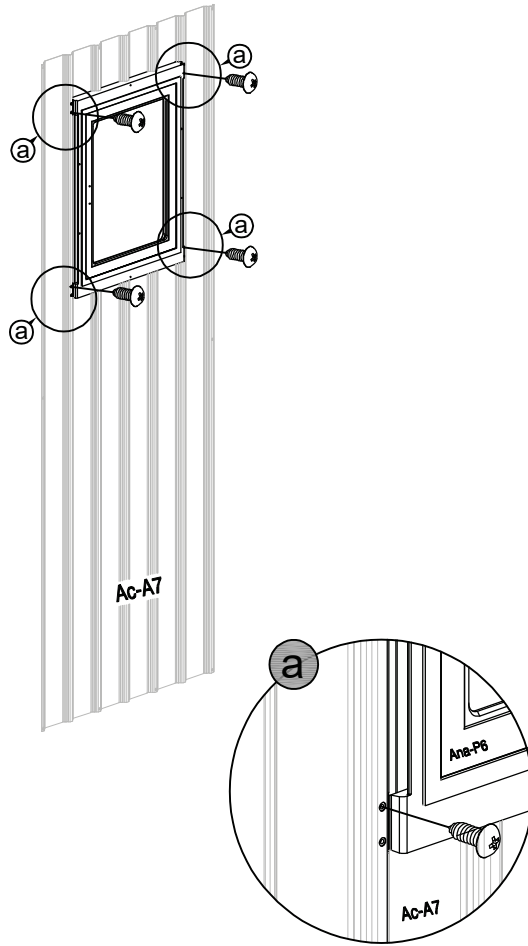

Ana-P6 x1

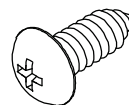

Anx-D41 x4

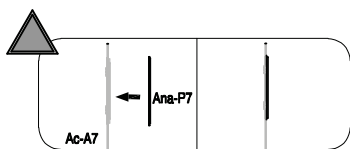
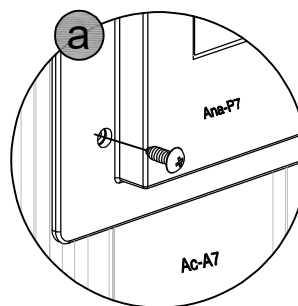
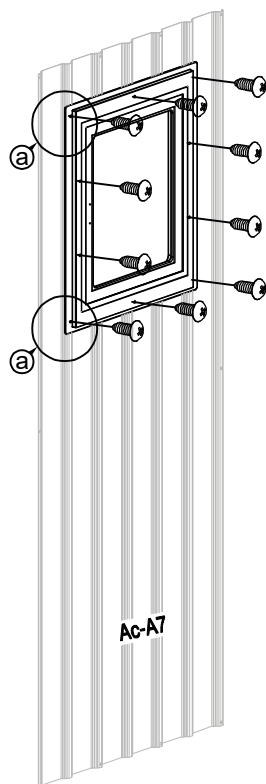

Ana-P7 x1

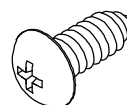

Anx-D41 x10

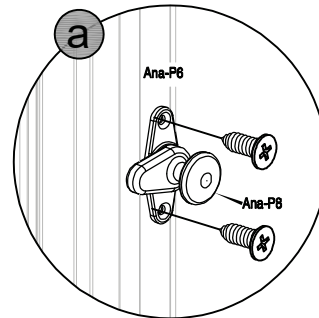
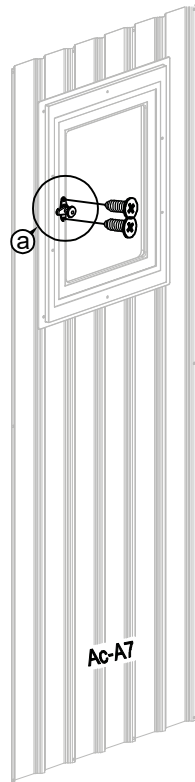

Ana-P8 x1



Ana-A42 x1

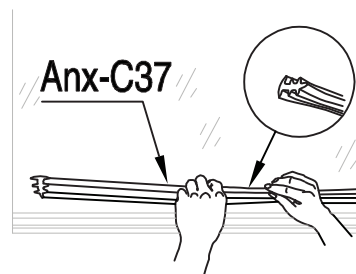
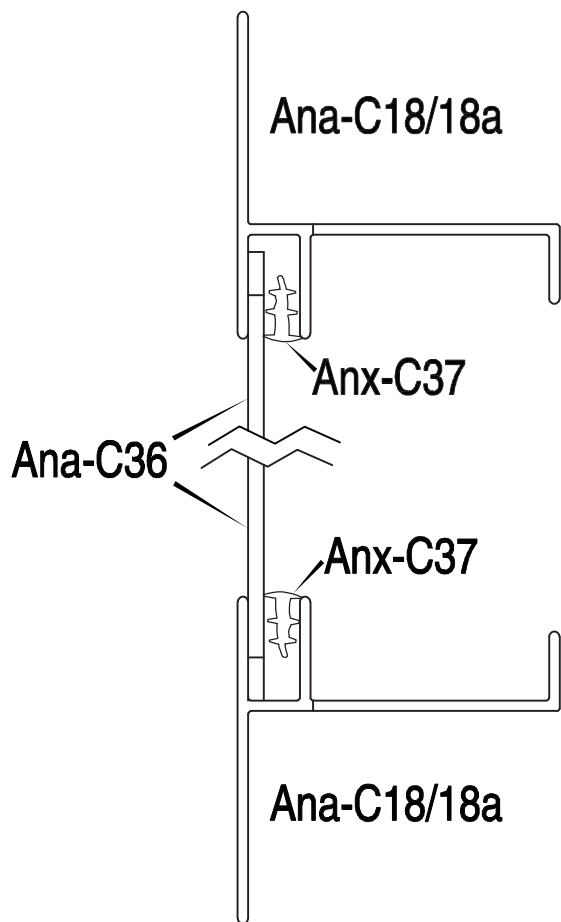

Anx-C37 x5.3M

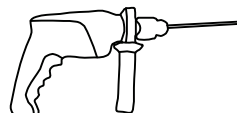
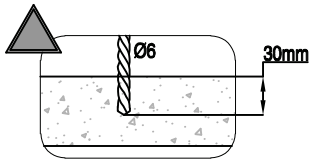
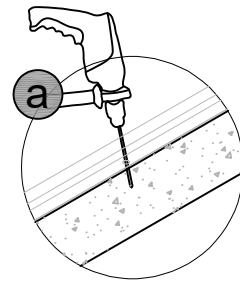
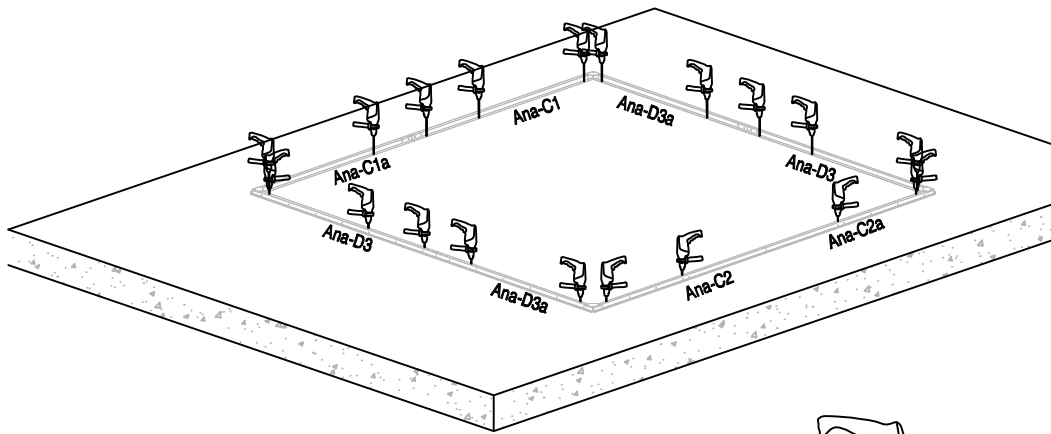

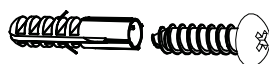
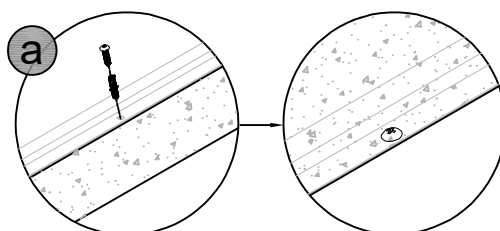
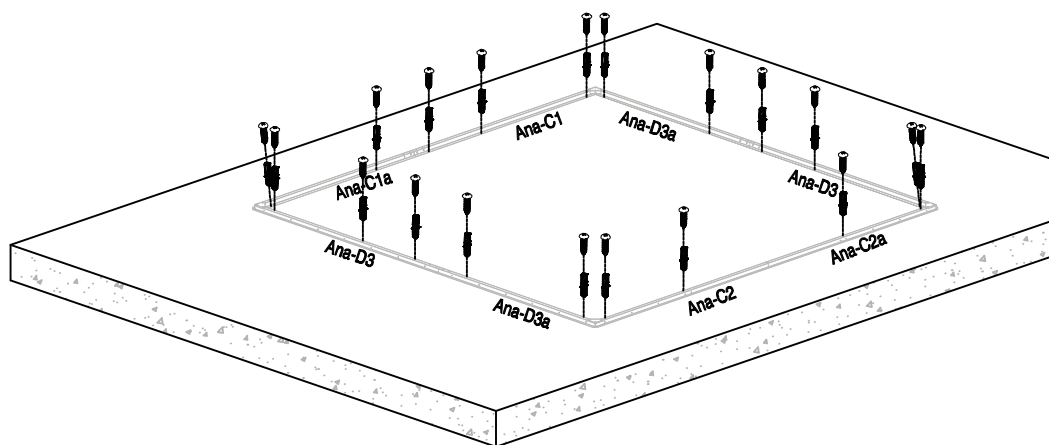

Anx-D45 x19

WARRANTY

Carefully inspect the contents of the package for missing or damaged components. If any parts are missing or damaged, do not return the product to the place of purchase; instead, contact the Gazebo Penguin Customer Experience Department

Montreal: (514) 276-3485

Elsewhere in Canada and the United States: 1-800-737-7174

info@gazebopenguin.com

This product has been designed and manufactured to meet the highest standards of quality and durability. Subject to the "Warranty Conditions" and "Warranty Limitations" sections below, it is warranted against defects in material or workmanship for:

- 1 YEAR ON MANUFACTURING DEFECTS

In the event that the product is damaged or the warranty period has expired, please contact the Penguin Gazebo Customer Experience Department for a complete list of replacement parts and prices.

WARRANTY LIMITATIONS AND EXCLUSIONS

1. This product is not warranted against damage caused by wind, falling objects, fire, animals, vegetation, vandalism and extreme weather conditions.
2. Collapses of shelters caused by snow, ice and wind accumulation
3. The roof must be kept free of snow and ice accumulation at all times.
4. Any damage that may be caused by snow and ice accumulation is not covered by the warranty. Snow and ice must be removed from the roof.
5. It is strongly recommended that the product not be placed adjacent to buildings or trees as snow or ice may slide off the roof. In the event that the product is placed adjacent to a building or tree, additional precautions must be taken to ensure that there is no accumulation of snow or ice that could cause excessive weight to the product.
6. The product is warranted only if installed in accordance with Gazebo Penguin's written instructions included with the product.
7. Leaks due to heavy rainfall may occur.
8. The product is not guaranteed if it has been anchored improperly.
9. We reserve the right to replace or repair any defective product or part at our sole discretion.
10. No modifications or additions to the product are permitted. This will void your warranty.
11. Warranty is non-transferable.
12. Does not cover labour, installation, or consequential damages.
13. Applies only to residential use within Canada.

GARANTIE

Inspectez soigneusement le contenu de l'emballage afin de vérifier que toutes les pièces soient dans les boîtes et qu'elles soient intactes. S'il manque des pièces ou si celles-ci sont endommagées, **NE RETOURNEZ PAS le produit à l'endroit où vous l'avez acheté** ; contactez plutôt le Département d'Expérience Client de Gazebo Penguin.

Montréal : (514) 276-3485

Ailleurs au Canada et États-Unis : 1-800-737-7174

info@gazebopenguin.com

Ce produit a été conçu et fabriqué afin de répondre aux normes les plus exigeantes en matière de qualité et de durabilité. Sous réserve des sections « conditions d'application de la garantie » et des « limitations à la garantie » ci-dessous, il est garanti contre les défauts matériels ou de fabrication :

• 1 AN SUR LES DÉFAUTS MANUFACTURIERS

Advenant que le produit soit endommagé ou que la période de garantie soit expirée, veuillez contacter le département d'expérience client de Gazebo Penguin afin d'obtenir une liste complète des pièces de remplacement et des prix.

LIMITATIONS ET EXCLUSIONS À LA GARANTIE

1. Ce produit n'est pas garanti contre les dommages causés par le vent, les chutes d'objets, le feu, les animaux, la végétation, le vandalisme ou les conditions météorologiques extrêmes.
2. Les effondrements d'abris causés par l'accumulation de neige, de glace ou de vent ne sont pas couverts.
3. Le toit doit être maintenu exempt de toute accumulation de neige et de glace en tout temps.
4. Tout dommage causé par l'accumulation de neige ou de glace n'est pas couvert par la garantie. La neige et la glace doivent être retirées du toit.
5. Il est fortement recommandé de ne pas installer le produit à proximité de bâtiments ou d'arbres, car la neige ou la glace pourrait glisser de leur toit. Si le produit est installé près d'un bâtiment ou d'un arbre, des précautions supplémentaires doivent être prises afin d'éviter toute accumulation de neige ou de glace pouvant entraîner une surcharge excessive sur la structure.
6. Le produit est garanti uniquement s'il est installé conformément aux instructions écrites de Gazebo Penguin fournies avec le produit.
7. Des infiltrations d'eau peuvent survenir lors de fortes pluies.
8. Le produit n'est pas garanti s'il a été mal ancré.
9. Nous nous réservons le droit de remplacer ou de réparer tout produit ou pièce défectueux, à notre seule discrétion.
10. Aucune modification ou ajout au produit n'est autorisé. Toute modification annulera la garantie.
11. La garantie est non transférable.
12. La garantie ne couvre pas la main-d'œuvre, l'installation ni les dommages indirects ou consécutifs.
13. La garantie s'applique uniquement à un usage résidentiel au Canada.